



BCT2014

0.7uA Low Power, Low Dropout, Linear Regulators

BCT2014

0.7uA Low Power, Low Dropout Linear Regulators

GENERAL DESCRIPTION

The BCT2014 series low-power, low-noise, low-dropout, CMOS linear voltage regulators operate from a 2.5V to 15.0V input voltage with 0.7uA low power. They are the perfect choice for low voltage, low power applications. A low ground current makes this part attractive for battery operated power systems. The BCT2014 series also offer ultra low dropout voltage to prolong battery life in portable electronics. Output current minimum limit is 300mA.

These devices feature a shutdown function and are offered in active low with auto discharge. The output voltage is preset to voltages in the range of 1.5V to 5.0V. Other features include a low shutdown current, fold-back current limit.

The BCT2014 is available in Green SOT23-3, SOT23-5, SC70-5, UTDFN1x1-4L and SOT89-3 packages. It operates over an ambient temperature range of -40°C to +85°C.

FEATURES

- Low Output Noise
- Low Power
- Low Dropout Voltage
- Output Current Limit
- 300mA Current Rating
- Available in Multiple output Voltage Versions
- Fixed Outputs of 1.5V, 1.8V, 3.0V, 3.3V, 4.2V, 4.5V and 5.0V
- -40°C to 85°C Operating Temperature Range
- Available in Green SOT23-3, SOT23-5, SC70-5, UTDFN1 x1-4L and SOT89-3 Packages.

APPLICATIONS

Cellular Telephones
Cordless Telephones
PCMCIA Cards
Modems
MP3 Player
Hand-Held Instruments
Portable/Battery-Powered Equipment



BCT2014

0.7uA Low Power, Low Dropout, Linear Regulators

ORDERING INFORMATION

Order Number	V _{OUT} (V)	Package Type	Temperature Range	Marking	QTY/Reel
BCT2014EUK15-TR	1.5	SOT23-5	-40°C to +85°C	H5XX	3000
BCT2014EUK18-TR	1.8	SOT23-5	-40°C to +85°C	H8XX	3000
BCT2014EUK30-TR	3.0	SOT23-5	-40°C to +85°C	H0XX	3000
BCT2014EUK33-TR	3.3	SOT23-5	-40°C to +85°C	H3XX	3000
BCT2014EUK42-TR	4.2	SOT23-5	-40°C to +85°C	H2XX	3000
BCT2014EUK45-TR	4.5	SOT23-5	-40°C to +85°C	H5XX	3000
BCT2014EUK50-TR	5.0	SOT23-5	-40°C to +85°C	H0XX	3000
BCT2014EUR15-TR	1.5	SOT23-3	-40°C to +85°C	H5XX	3000
BCT2014EUR18-TR	1.8	SOT23-3	-40°C to +85°C	H8XX	3000
BCT2014EUR30-TR	3.0	SOT23-3	-40°C to +85°C	H0XX	3000
BCT2014EUR33-TR	3.3	SOT23-3	-40°C to +85°C	H3XX	3000
BCT2014EUR42-TR	4.2	SOT23-3	-40°C to +85°C	H2XX	3000
BCT2014EUR45-TR	4.5	SOT23-3	-40°C to +85°C	H5XX	3000
BCT2014EUR50-TR	5.0	SOT23-3	-40°C to +85°C	H0XX	3000
BCT2014EXK15-TR	1.5	SC70-5	-40°C to +85°C	H5XX	3000
BCT2014EXK18-TR	1.8	SC70-5	-40°C to +85°C	H8XX	3000
BCT2014EXK30-TR	3.0	SC70-5	-40°C to +85°C	H0XX	3000
BCT2014EXK33-TR	3.3	SC70-5	-40°C to +85°C	H3XX	3000
BCT2014EXK42-TR	4.2	SC70-5	-40°C to +85°C	H2XX	3000
BCT2014EXK45-TR	4.5	SC70-5	-40°C to +85°C	H5XX	3000
BCT2014EXK50-TR	5.0	SC70-5	-40°C to +85°C	H0XX	3000
BCT2014ELS15-TR	1.5	UTDFN1x1-4L	-40°C to +85°C	H5X	10000
BCT2014ELS18-TR	1.8	UTDFN1x1-4L	-40°C to +85°C	H8X	10000
BCT2014ELS30-TR	3.0	UTDFN1x1-4L	-40°C to +85°C	H0X	10000
BCT2014ELS33-TR	3.3	UTDFN1x1-4L	-40°C to +85°C	H3X	10000
BCT2014ELS42-TR	4.2	UTDFN1x1-4L	-40°C to +85°C	H2X	10000
BCT2014ELS45-TR	4.5	UTDFN1x1-4L	-40°C to +85°C	H5X	10000
BCT2014ELS50-TR	5.0	UTDFN1x1-4L	-40°C to +85°C	H0X	10000



BCT2014

0.7uA Low Power, Low Dropout, Linear Regulators

Order Number	V _{OUT} (V)	Package Type	Temperature Range	Marking	QTY/Reel
BCT2014EJR15-TR	1.5	SOT89-3	-40°C to +85°C	2014 15XXX	3000
BCT2014EJR18-TR	1.8	SOT89-3	-40°C to +85°C	2014 18XXX	3000
BCT2014EJR30-TR	3.0	SOT89-3	-40°C to +85°C	2014 30XXX	3000
BCT2014EJR33-TR	3.3	SOT89-3	-40°C to +85°C	2014 33XXX	3000
BCT2014EJR42-TR	4.2	SOT89-3	-40°C to +85°C	2014 42XXX	3000
BCT2014EJR45-TR	4.5	SOT89-3	-40°C to +85°C	2014 45XXX	3000
BCT2014EJR50-TR	5.0	SOT89-3	-40°C to +85°C	2014 50XXX	3000

Note:

"XXX" in Marking will be appeared as the batch code.



BCT2014

0.7uA Low Power, Low Dropout, Linear Regulators

ABSOLUTE MAXIMUM RATINGS

IN to GND.....	-0.3V to 16.0V
EN to GND.....	-0.3V to V_{IN}
OUT to GND.....	-0.3V to 5.5V
Output Short-Circuit Duration.....	Infinite
Power Dissipation, $P_D @ T_A=25^\circ\text{C}$	
SOT23-3.....	0.42W
SOT23-5.....	0.48W
SC70-5.....	0.38W
UTDFN1x1-4L.....	0.45W
SOT89-3.....	1.25W
Package Thermal Resistance	
SOT23-3, θ_{JA}	300°C/W
SOT23-5, θ_{JA}	260°C/W
SC70-5, θ_{JA}	330°C/W
UTDFN1x1-4L.....	280°C/W
SOT89-3, θ_{JA}	100°C/W
Junction Temperature.....	150°C
Storage Temperature Range.....	-65°C to 150°C
Lead Temperature (Soldering, 10 sec).....	260°C
ESD Susceptibility	
HBM.....	4000V
MM.....	400V

RECOMMENDED OPERATING CONDITIONS

Operating Voltage Range.....	2.5V to 15V
Operating Temperature Range	-40°C to $+85^\circ\text{C}$

OVERSTRESS CAUTION

Stresses beyond those listed under "Absolute Maximum Ratings" may cause permanent damage to the device. These are stress ratings only, and functional operation of the device at these or any other conditions beyond those indicated in the operational sections of the specifications is not implied. Exposure to absolute maximum rating conditions for extended periods may affect device reliability.

ESD SENSITIVITY CAUTION

This integrated circuit can be damaged by ESD if you don't pay attention to ESD protection. Broadchip recommends that all integrated circuits be handled with appropriate precautions. Failure to observe proper handling and installation procedures can cause damage. ESD damage can range from subtle performance degradation to complete device failure. Precision integrated circuits may be more susceptible to damage because very small parametric changes could cause the device not to meet its published specifications.

DISCLAIMER

Broadchip reserves the right to make any change in circuit design, specification or other related things if necessary without notice at any time. Please contact Broadchip sales office to get the latest datasheet.

PIN CONFIGURATION (TOP VIEW)

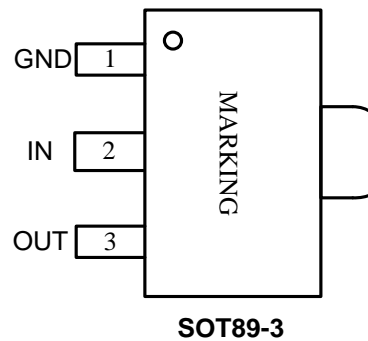
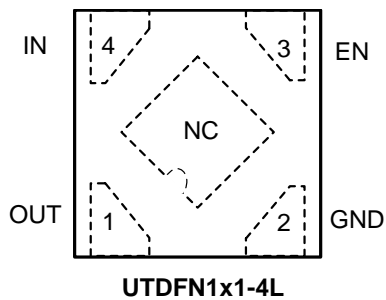
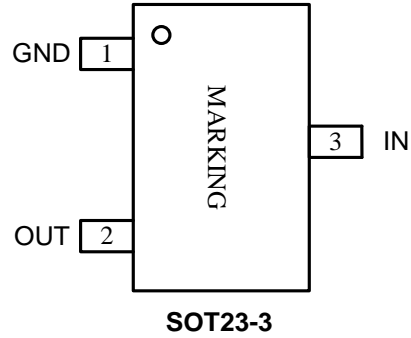
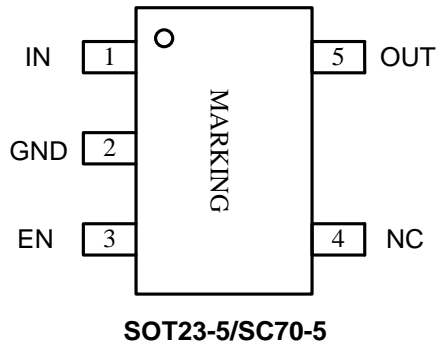

PIN DESCRIPTION

PIN				NAME	FUNCTION
SOT23-5/ SC70-5	SOT23-3	UTDFN1x1 -4L	SOT89-3		
1	3	4	2	IN	Regulator Input. Supply voltage can range from 2.5V to 15.0V. Bypass with a 1uF capacitor to GND.
2	1	2	1	GND	Ground.
3	-	3	-	EN	Shutdown Input. A logic low reduces the supply current to 10nA. Connect to IN for normal operation.
4	-	-	-	NC	No Connect
5	2	1	3	OUT	Regulator Output.

ELECTRICAL CHARACTERISTICS

($V_{IN} = V_{OUT(NOMINAL)} + 1V^{(1)}$, $T_A = -40^{\circ}C$ to $+85^{\circ}C$, unless otherwise specified.)

PARAMETER	SYM	CONDITIONS	MIN	TYP	MAX	UNITS
Input Voltage	V_{IN}		2.5		15.0	V
Output Voltage Accuracy ⁽¹⁾		$I_{OUT}=30mA$	-2.0		2.0	%
Maximum Output Current				300		mA
Current Limit	I_{LIM}			500		mA
Short-Circuit Current ⁽¹⁾	I_{SHORT}	$V_{IN} = V_{OUT} + 1V$		0.03		A
Ground Pin Current	I_Q	No load		0.7	1.5	uA
Dropout Voltage ⁽²⁾		$I_{OUT}=100mA$		160		mV
		$I_{OUT}=200mA$		320		
Line Regulation	ΔV_{LNR}	$V_{OUT} + 1V \leq V_{IN} \leq 15V$, $I_{OUT}=10mA$		0.022		%/V
Load Regulation	ΔV_{LDR}	$I_{OUT}=1mA$ to $100mA$, $C_{OUT}=1\mu F$, $V_{OUT}>2V$		0.002		%/mA
		$I_{OUT}=1mA$ to $100mA$, $C_{OUT}=1\mu F$, $V_{OUT} \leq 2V$		0.004		
Power Supply Rejection Ratio	PSRR	$I_{OUT} = 30mA$, $C_{OUT} = 1\mu F$, $V_{IN} = V_{OUT} + 1V$, $\Delta V_{RIPPLE} = 0.2V_{P-P}$, $f = 1kHz$		40		dB
SHUTDWON⁽³⁾						
EN Input Threshold	V_{IH}	$V_{IN}=2.5V$ to $15.0V$,	2.5			V
	V_{IL}				0.7	
EN Input Bias Current	$I_{B(SHDN)}$	EN=0V		0.01	0.1	uA

NOTES:

- $V_{IN} = V_{OUT} (NOMINAL) + 1V$, whichever is greater.
- The dropout voltage is defined as $V_{IN} - V_{OUT}$, when V_{OUT} is 100mV below the value of V_{OUT} for $V_{IN} = V_{OUT} + 1V$.
(Only applicable for $V_{OUT} = +1V$.)
- $V_{EN} = -0.3V$ to V_{IN}

TYPICAL APPLICATION CIRCUIT

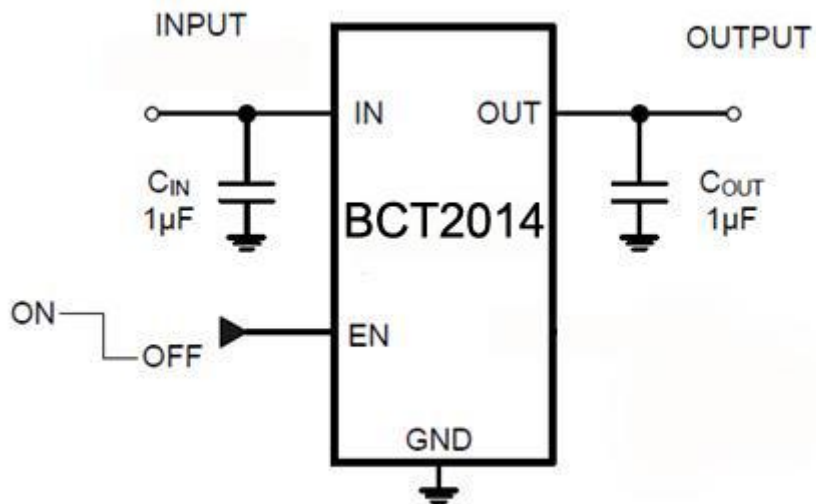

NOTES: If has a large Load Transient in the application, recommend using 4.7uF or more in C_{out} .

PACKAGE OUTLINE DIMENSIONS

SOT23-3

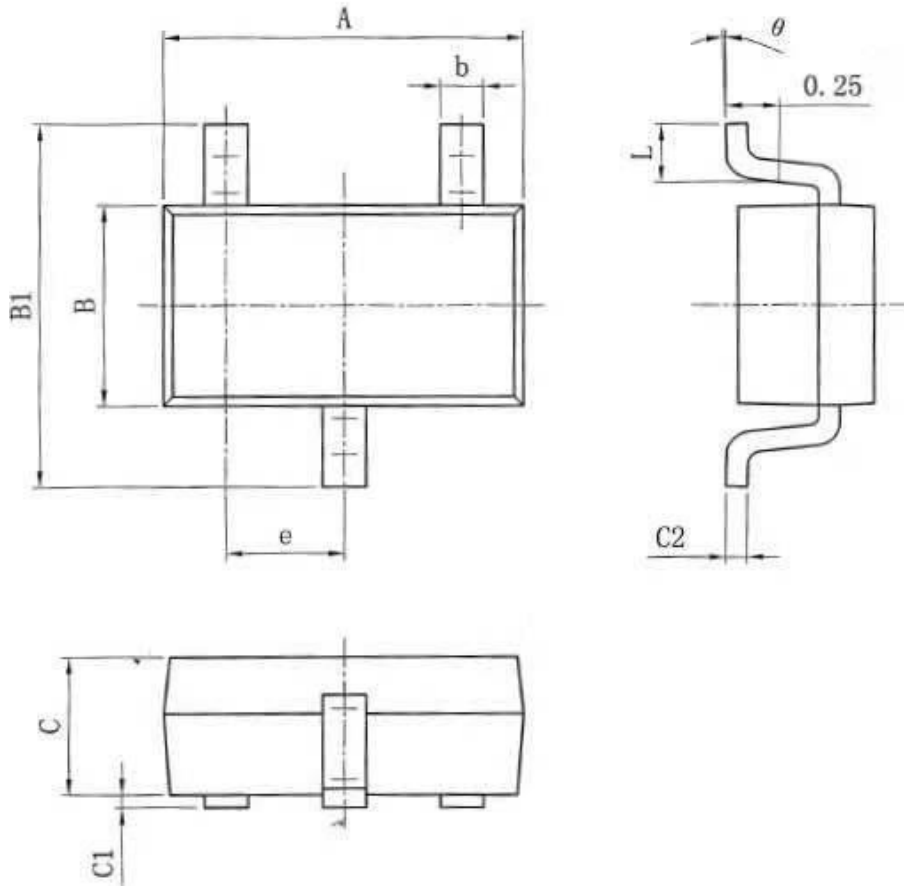

Symbol	Dimensions In Millimeters	
	Min	Max
A	2.82	3.02
e	0.95(BSC)	
b	0.28	0.45
B	1.50	1.70
B1	2.75	3.05
C	1.05	1.15
C1	0.03	0.15
C2	0.12	0.23
L	0.35	0.55
θ	0°	8°

SOT23-3 Surface Mount Package

SOT23-5

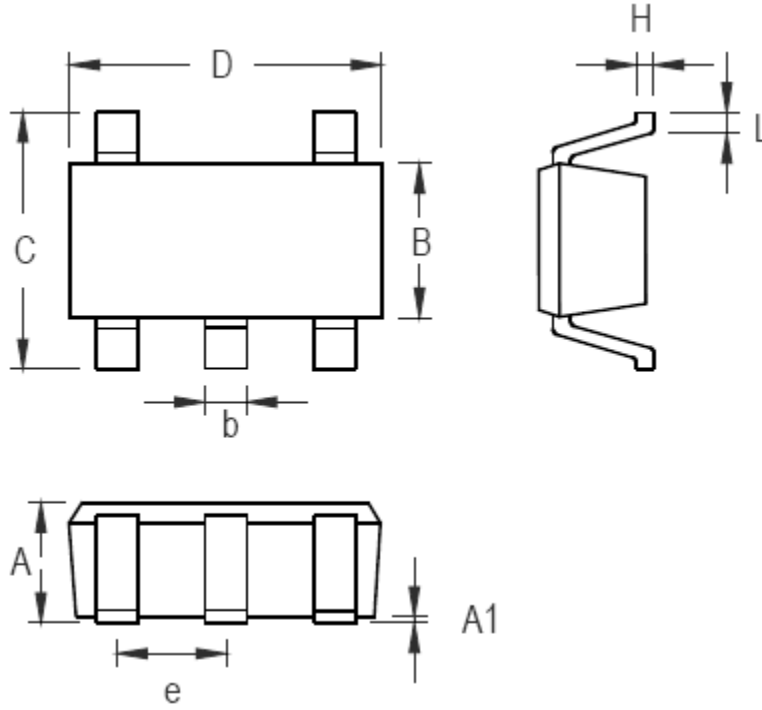

Symbol	Dimensions In Millimeters	
	Min	Max
A	1.05	1.15
A1	0.03	0.15
B	1.5	1.7
b	0.28	0.45
C	2.75	3.05
D	2.82	3.02
e	0.95(BSC)	
H	0.12	0.23
L	0.35	0.55

SOT23-5 Surface Mount Package

SC70-5

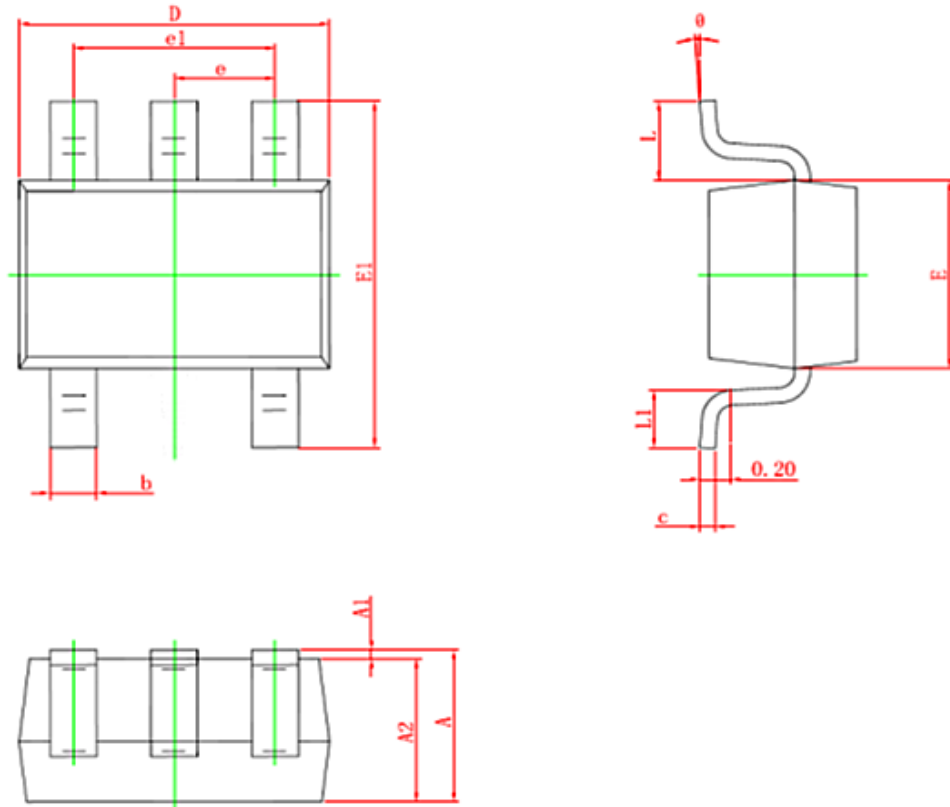

Symbol	Dimensions In Millimeters		Dimensions In Inches	
	Min.	Max.	Min.	Max.
A	0.900	1.100	0.035	0.043
A1	0.000	0.100	0.000	0.004
A2	0.900	1.000	0.035	0.039
b	0.150	0.350	0.006	0.014
c	0.110	0.175	0.004	0.007
D	2.000	2.200	0.079	0.087
E	1.150	1.350	0.045	0.053
E1	2.150	2.450	0.085	0.096
e	0.650 TYP.		0.026 TYP.	
e1	1.200	1.400	0.047	0.055
L	0.525 REF.		0.021 REF.	
L1	0.260	0.460	0.010	0.018
θ	0°	8°	0°	8°

SC70-5 Surface Mount Package

UTDFN1x1-4L

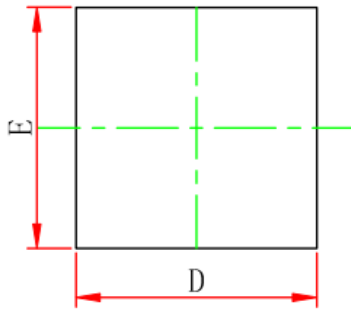

TOP VIEW

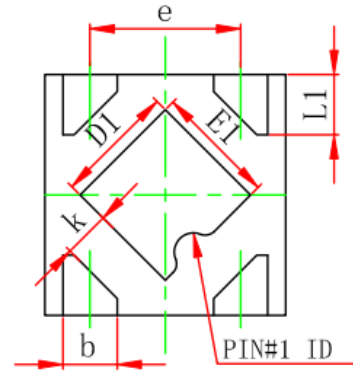

BOTTOM VIEW

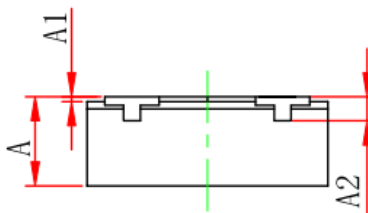

SIDE VIEW

Symbol	Dimensions In Millimeters	
	Min	Max
A	0.335	0.405
A1	0.000	0.050
A2	0.100 REF	
D	0.950	1.050
D1	0.450	0.550
E	0.950	1.050
E1	0.450	0.550
K	0.195 REF	
b	0.175	0.275
e	0.575	0.675
L	0.200	0.300

UTDFN1x1-4L Surface Mount Package

SOT89-3

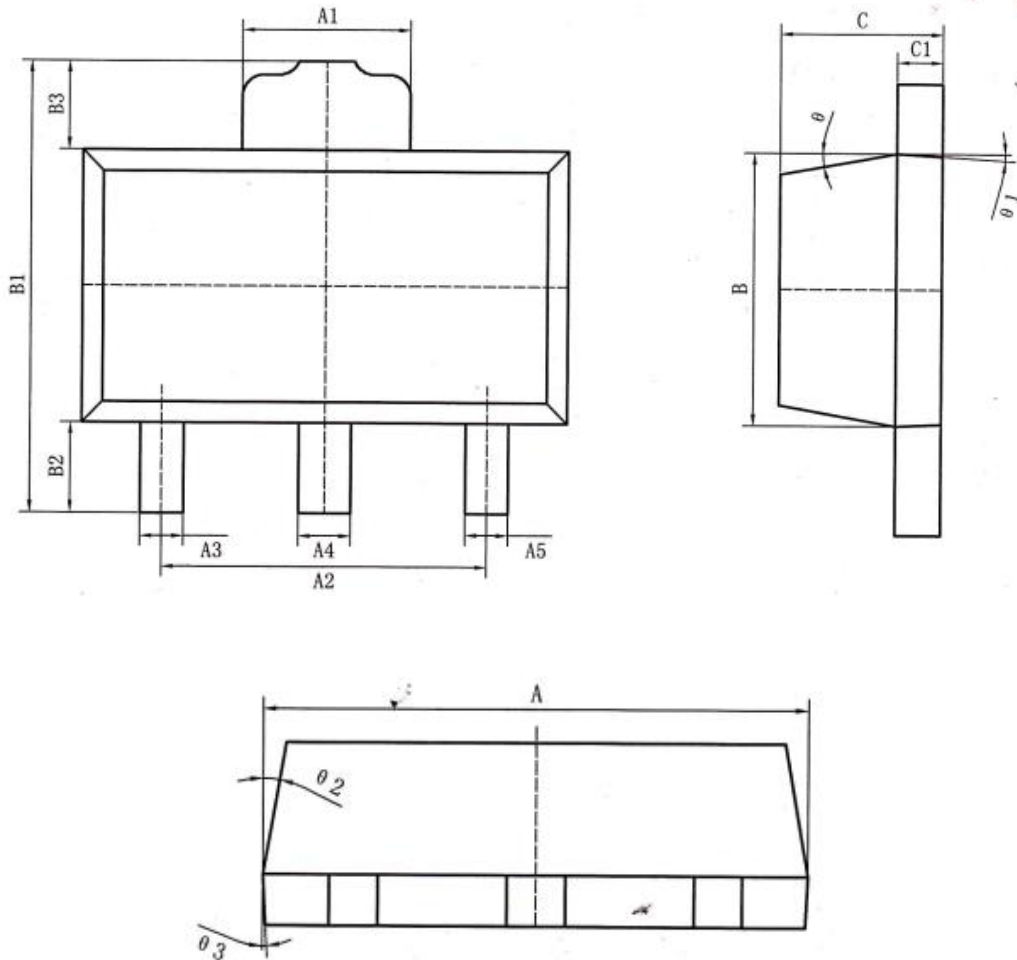

标注	尺寸	最小(mm)	最大(mm)	标注	尺寸	最小(mm)	最大(mm)
A		4.40	4.60	B3		0.82	0.83
A1		1.65	1.75	C		1.40	1.60
A2		2.95	3.05	C1		0.35	0.45
A3		0.35	0.45	theta		6° TYP4	
A4		0.43	0.53	theta 1		3° TYP4	
A5		0.35	0.45	theta 2		6° TYP4	
B		2.40	2.60	theta 3		3° TYP4	
B1		4.05	4.25				
B2		0.82	0.83				

SOT89-3 Surface Mount Package

LAND PATTERN DATA

SOT23-5

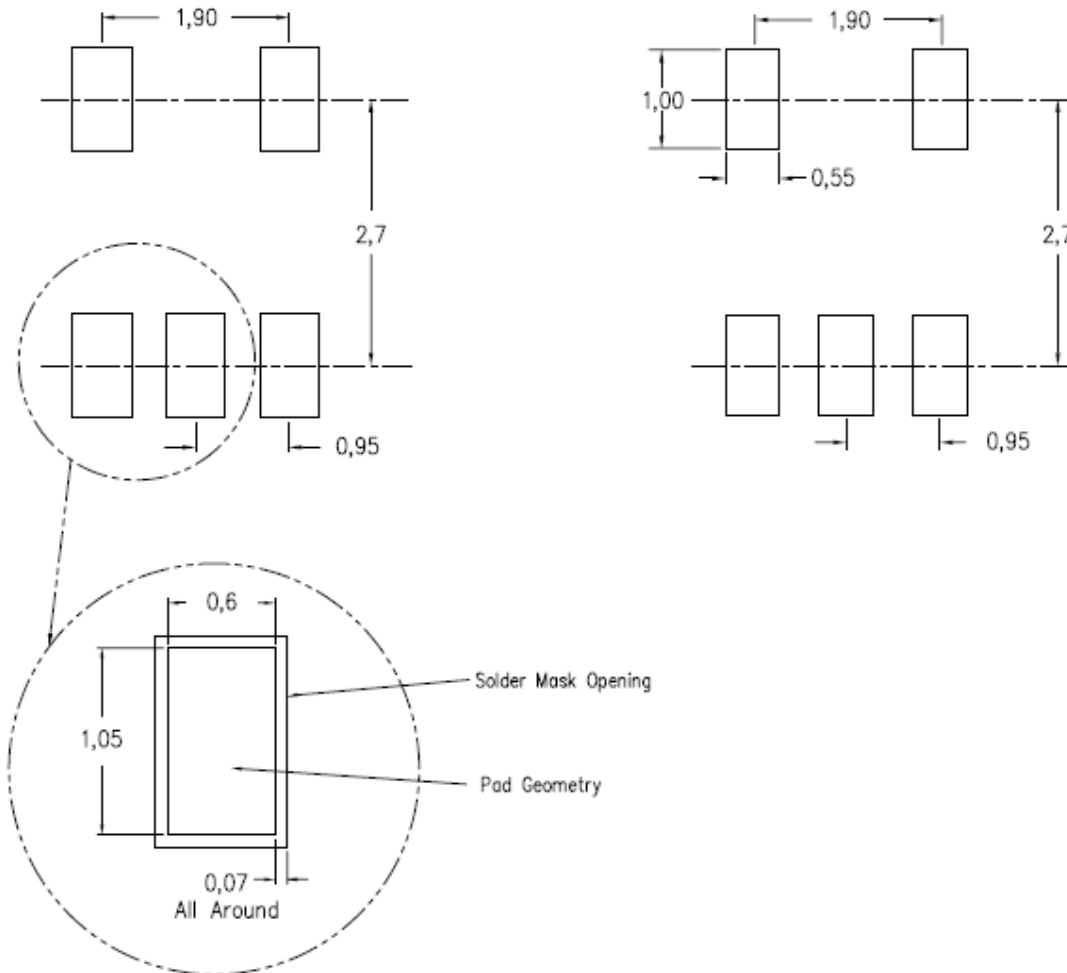

RECOMMENDED PCB LAYOUT PATTERN (Unit: mm)

SOT23-3

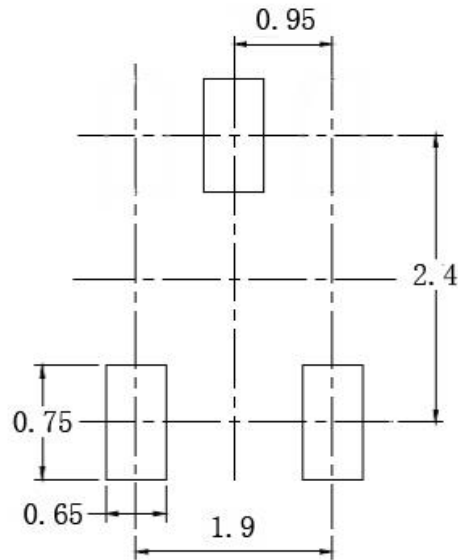

RECOMMENDED PCB LAYOUT PATTERN (Unit: mm)

SC70-5

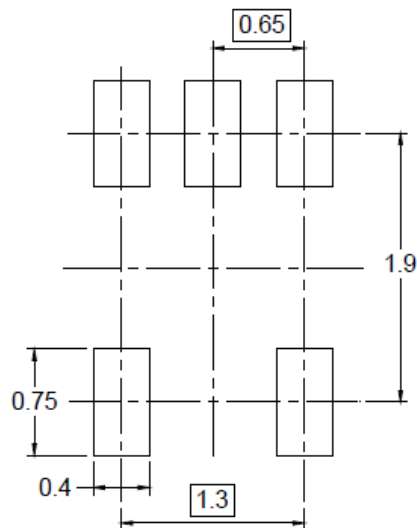

RECOMMENDED PCB LAYOUT PATTERN (Unit: mm)

UTDFN1x1-4L

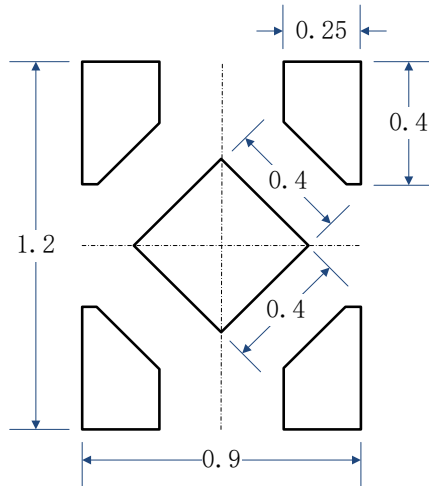

RECOMMENDED PCB LAYOUT PATTERN (Unit: mm)

SOT89-3

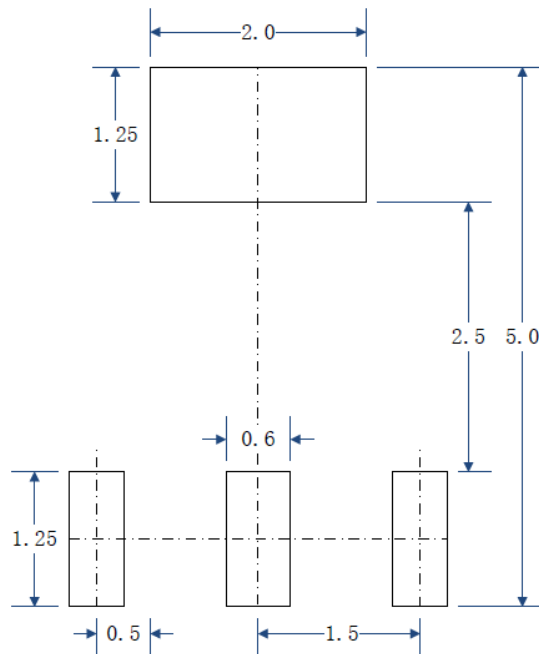

RECOMMENDED PCB LAYOUT PATTERN (Unit: mm)

X-ON Electronics

Largest Supplier of Electrical and Electronic Components

Click to view similar products for [Linear Voltage Regulators](#) category:

Click to view products by [BROADCHIP](#) manufacturer:

Other Similar products are found below :

[LV56831P-E](#) [LV5684PVD-XH](#) [MCDTSA6-2R](#) [L7815ACV-DG](#) [PQ3DZ53U](#) [LV56801P-E](#) [TLE42794G](#) [L78L05CZ/1SX](#) [L78LR05DL-MA-E](#) [636416C](#) [714954EB](#) [BA033LBSG2-TR](#) [LV5680P-E](#) [L78M15CV-DG](#) [L79M05T-E](#) [TLS202A1MBVHTSA1](#) [L78LR05D-MA-E](#) [NCV317MBTG](#) [NTE7227](#) [LV5680NPVC-XH](#) [LT1054CN8](#) [MP2018GZD-5-Z](#) [MP2018GZD-33-Z](#) [MIC5281-3.3YMM](#) [MC78L06BP-AP](#) [TA48LS05F\(TE85L,F\)](#) [TA78L12F\(TE12L,F\)](#) [TC47BR5003ECT](#) [TCR2LN12,LF\(S](#) [TCR2LN28,LF\(S](#) [TCR2LN30,LF\(S](#) [TCR3DF295,LM\(CT](#) [TCR3DF40,LM\(CT](#) [BA178M20CP-E2](#) [L78M12ABDT](#) [LM7812SX/NOPB](#) [LR645N3-G-P003](#) [LR645N3-G-P013](#) [ZXTR2005P5-13](#) [SCD7812BTG](#) [TCR3DF335,LM\(CT](#) [ZXTR2012K-13](#) [TLE42994E V33](#) [ZXTR2008K-13](#) [ZXTR2005K-13](#) [L88R05DL-E](#) [ADP3300ARTZ-2.7RL7](#) [LM120K-15/883](#) [IFX54441LDVXUMA1](#) [LM317D2T-TR](#)