



BCT2036

Low Power, Low Dropout RF-Linear Regulators

BCT2036

Low Power, Low Dropout, RF-Linear Regulators

GENERAL DESCRIPTION

The BCT2036 series low-power, low-dropout, CMOS linear voltage regulators operate from a 1.6V to 5.5V input voltage and deliver up to 300mA output current. They are the perfect choice for low voltage, low power applications. A low ground current makes this part attractive for battery operated power systems. The BCT2036 series also offer low dropout voltage to prolong battery life in portable electronics. Systems requiring a quiet voltage source, such as RF applications, will benefit from the BCT2036 series low output noise and high PSRR.

Other features include a 10nA logic-controlled shutdown mode, short current limit and thermal shutdown protection.

The BCT2036 has auto-discharge function to quickly discharge VOUT in the disable status.

The BCT2036 is available in Green SOT23-3, SOT23-5, SC70-5, UTDFN1X1-4L packages. It operates over an ambient temperature range of -40°C to +85°C .

FEATURES

- Low Dropout Voltage
- Thermal Overload Protection
- Built-In Fold Back Protection Circuit
- 20µA Low Supply Current
- 10nA Logic-Controlled Shutdown
- 1.6V to 5.5V Input Voltage Range
- Fixed Outputs of 1.2V, 1.8V, 2.8V, 3.0V, and 3.3V
- Adjustable Output from 0.8V to 5.0V
- Short Auto-Discharge Function
- 300mA Output Current
- High Output Voltage Accuracy
- Quick Start-Up Time
- -40°C to +85°C Operating Temperature Range Available in Green SOT23-3, SOT23-5, UTDFN1X1-4L, SC70-5 Packages.

APPLICATIONS

Cellular Telephones
Cordless Telephones
PCMCIA Cards
Modems
MP3 Player
Hand-Held Instruments
Palmtop Computers
Electronic Planners
Portable/Battery-Powered Equipment



BCT2036

Low Power, Low Dropout RF-Linear Regulators

ORDERING INFORMATION

Order Number	V _{OUT} (V)	Package Type	Temperature Range	Marking	QTY/Reel
BCT2036EUR12-TR	1.2	SOT23-3	-40°C to +85°C	B2XX	3000
BCT2036EUR18-TR	1.8	SOT23-3	-40°C to +85°C	B8XX	3000
BCT2036EUR28-TR	2.8	SOT23-3	-40°C to +85°C	B8XX	3000
BCT2036EUR30-TR	3.0	SOT23-3	-40°C to +85°C	B0XX	3000
BCT2036EUR33-TR	3.3	SOT23-3	-40°C to +85°C	B3XX	3000
BCT2036EUK12-TR	1.2	SOT23-5	-40°C to +85°C	B2XX	3000
BCT2036EUK18-TR	1.8	SOT23-5	-40°C to +85°C	B8XX	3000
BCT2036EUK28-TR	2.8	SOT23-5	-40°C to +85°C	B8XX	3000
BCT2036EUK30-TR	3.0	SOT23-5	-40°C to +85°C	B0XX	3000
BCT2036EUK33-TR	3.3	SOT23-5	-40°C to +85°C	B3XX	3000
BCT2036EUKVAD-TR	ADJ	SOT23-5	-40°C to +85°C	BAXX	3000
BCT2036EXK12-TR	1.2	SC70-5	-40°C to +85°C	B2XX	3000
BCT2036EXK18-TR	1.8	SC70-5	-40°C to +85°C	B8XX	3000
BCT2036EXK28-TR	2.8	SC70-5	-40°C to +85°C	B8XX	3000
BCT2036EXK30-TR	3.0	SC70-5	-40°C to +85°C	B0XX	3000
BCT2036EXK33-TR	3.3	SC70-5	-40°C to +85°C	B3XX	3000
BCT2036EXKVAD-TR	ADJ	SC70-5	-40°C to +85°C	BAXX	3000
BCT2036ELS12-TR	1.2	UTDFN1x1-4L	-40°C to +85°C	B2X	10000
BCT2036ELS18-TR	1.8	UTDFN1x1-4L	-40°C to +85°C	B8X	10000
BCT2036ELS28-TR	2.8	UTDFN1x1-4L	-40°C to +85°C	B8X	10000
BCT2036ELS30-TR	3.0	UTDFN1x1-4L	-40°C to +85°C	B0X	10000
BCT2036ELS33-TR	3.3	UTDFN1x1-4L	-40°C to +85°C	B3X	10000

Note:

"B" in Marking is product short code for BCT2036

"XX" or "X" in Marking will be appeared as the batch code.



BCT2036

Low Power, Low Dropout RF-Linear Regulators

ABSOLUTE MAXIMUM RATINGS

IN to GND.....	-0.3V to 6.0V
Output Short-Circuit Duration.....	Infinite
EN to GND.....	-0.3V to 6.0V
OUT,BP/FB to GND.....	-0.3V to (VIN +0.3V)
Power Dissipation, P _D @T _A =25°C	
SOT23-3.....	0.42W
SOT23-5.....	0.48W
SC70-5.....	0.38W
UTDFN1x1-4L.....	0.45W
Package Thermal Resistance	
SOT23-3.....	300°C/W
SOT23-5, θ _{JA}	260°C/W
SC70-5, θ _{JA}	330°C/W
UTDFN1x1-4L.....	280°C/W
Junction Temperature.....	150°C
Storage Temperature Range.....	-65°C to 150°C
Lead Temperature (Soldering, 10 sec).....	260°C
ESD Susceptibility	
HBM.....	4000V
MM.....	400V

RECOMMENDED OPERATING CONDITIONS

Operating Voltage Range.....	1.6V to 5.5V
Operating Temperature Range	-40°C to +85°C

OVERSTRESS CAUTION

Stresses beyond those listed under “Absolute Maximum Ratings” may cause permanent damage to the device. These are stress ratings only, and functional operation of the device at these or any other conditions beyond those indicated in the operational sections of the specifications is not implied. Exposure to absolute maximum rating conditions for extended periods may affect device reliability.

ESD SENSITIVITY CAUTION

This integrated circuit can be damaged by ESD if you don't pay attention to ESD protection. Broadchip recommends that all integrated circuits be handled with appropriate precautions. Failure to observe proper handling and installation procedures can cause damage. ESD damage can range from subtle performance degradation to complete device failure. Precision integrated circuits may be more susceptible to damage because very small parametric changes could cause the device not to meet its published specifications.

DISCLAIMER

Broadchip reserves the right to make any change in circuit design, specification or other related things if necessary without notice at any time. Please contact Broadchip sales office to get the latest datasheet.

PIN CONFIGURATION

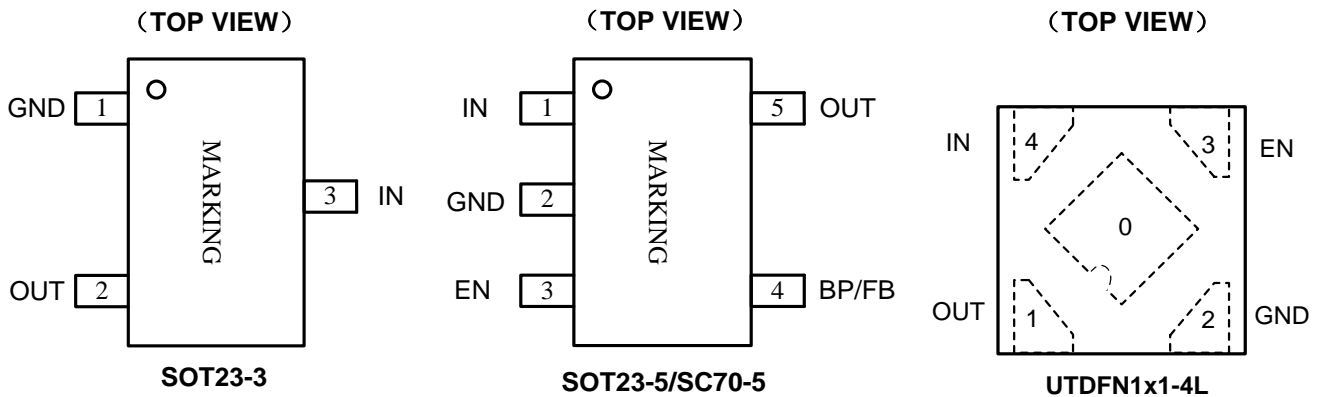

PIN DESCRIPTION

PIN			NAME	FUNCTION
UTDFN 1X1-4L	SOT23-5 SC70-5	SOT23-3		
1	5	2	OUT	Regulator Output.
2	2	1	GND	Ground.
3	3	-	EN	Enable Pin. This pin has an internal pull-down resistor. A logic low reduces the supply current to less than 1µA. Connect to IN for normal operation.
4	1	3	IN	Regulator Input. Supply voltage can range from 1.6V to 5.5V. Bypass with a 1µF capacitor to GND.
-	4	-	BP	Reference-Noise Bypass Pin (fixed voltage version only). Bypass with a low-leakage 0.01µF ceramic capacitor for reduced noise at the output. The capacitor is recommended to be placed very close to the pin for high PSRR.
-	-	-	FB	Adjustable Voltage Version Only. This is used to set the output voltage of the device.
0	-	-	Exposed Pad	The exposed pad should be connected to a large ground plane to maximize thermal performance.

ELECTRICAL CHARACTERISTICS

($V_{IN} = V_{OUT(NOMINAL)} + 0.5V$ or $1.6V$, whichever is greater, Full = $-40^{\circ}C$ to $+85^{\circ}C$, unless otherwise noted.)

PARAMETER	SYMBOL	CONDITIONS	TEMP	MIN	TYP	MAX	UNITS	
Input Voltage	V_{IN}		$+25^{\circ}C$	1.6		5.5	V	
Output Voltage Accuracy		$I_{OUT} = 0.1mA$	$+25^{\circ}C$	-2.5		+2.5	%	
Feedback Voltage	V_{FB}	$I_{OUT} = 0.1mA$, BCT2036-ADJ	$+25^{\circ}C$	0.78	0.8	0.82	V	
Maximum Output Current (1)			$+25^{\circ}C$	300			mA	
Current Limit	I_{LIM}		$+25^{\circ}C$	360	560		mA	
Ground Pin Current	I_Q	No Load, $V_{EN} = V_{IN}$	$+25^{\circ}C$		20	26	μA	
Dropout Voltage (2)	V_{DROP}	$I_{OUT} = 300mA$	$1.2V \leq V_{OUT} < 1.8V$	$+25^{\circ}C$		590	800	mV
			$1.8V \leq V_{OUT} < 2.5V$	$+25^{\circ}C$		320	420	
			$2.5V \leq V_{OUT} < 3.0V$	$+25^{\circ}C$		215	280	
			$3.0V \leq V_{OUT} < 3.6V$	$+25^{\circ}C$		190	250	
Line Regulation	$\frac{\Delta V_{OUT}}{\Delta V_{IN} \times V_{OUT}}$	$V_{IN} = 1.6V$ or ($V_{OUT} + 0.5V$) to $5.5V$, $I_{OUT} = 1mA$	$1.8V \leq V_{OUT} \leq 3.3V$	$+25^{\circ}C$		0.01	0.06	%/ V
			$V_{OUT} < 1.8V$ or $V_{OUT} > 3.3V$	$+25^{\circ}C$		0.01	0.1	
Load Regulation	ΔV_{OUT}	$I_{OUT} = 0.1mA$ to $300mA$	$+25^{\circ}C$		12	40	mV	
Short Current Limit	I_{SHORT}	$V_{OUT} = 0V$	$+25^{\circ}C$		200		mA	
Power Supply Rejection Ratio	PSRR	$C_{BP} = 0\mu F$, $I_{OUT} = 30mA$, $C_{OUT} = 1\mu F$, $V_{IN} = 2.8V$, $V_{OUT} = 1.8V$, $\Delta V_{RIPPLE} = 0.2V_{P-P}$	$f = 217Hz$	$+25^{\circ}C$		80		dB
			$f = 1kHz$	$+25^{\circ}C$		70		
		$C_{BP} = 0.01\mu F$, $I_{OUT} = 30mA$, $C_{OUT} = 1\mu F$, $V_{IN} = 2.8V$, $V_{OUT} = 1.8V$, $\Delta V_{RIPPLE} = 0.2V_{P-P}$	$f = 217Hz$	$+25^{\circ}C$		82		
			$f = 1kHz$	$+25^{\circ}C$		75		
Output Voltage Noise	e_n	$C_{BP} = 0\mu F$, $f = 10Hz$ to $100kHz$, $C_{OUT} = 1\mu F$, $V_{IN} = 2.8V$, $V_{OUT} = 1.8V$	$I_{OUT} = 0mA$	$+25^{\circ}C$		70		μV_{RMS}
			$I_{OUT} = 30mA$	$+25^{\circ}C$		100		
		$C_{BP} = 0.01\mu F$, $f = 10Hz$ to $100kHz$, $C_{OUT} = 1\mu F$, $V_{IN} = 2.8V$, $V_{OUT} = 1.8V$	$I_{OUT} = 0mA$	$+25^{\circ}C$		25		
			$I_{OUT} = 30mA$	$+25^{\circ}C$		65		
Output Voltage Temperature Coefficient (3)	$\frac{\Delta V_{OUT}}{\Delta T_A \times V_{OUT}}$	$I_{OUT} = 0.1mA$	Full		30		ppm/ $^{\circ}C$	



BCT2036

Low Power, Low Dropout RF-Linear Regulators

ELECTRICAL CHARACTERISTICS (continued)

($V_{IN} = V_{OUT(NOMINAL)} + 0.5V$ or $1.6V$, whichever is greater, Full = $-40^{\circ}C$ to $+85^{\circ}C$, unless otherwise noted.)

PARAMETER	SYMBOL	CONDITIONS	TEMP	MIN	TYP	MAX	UNITS
SHUTDOWN							
EN Input Threshold	V_{IH}	$V_{IN} = 1.6V$ to $5.5V$	Full	1.5			V
	V_{IL}		Full			0.4	
EN Input Bias Current	I_{BH}	$V_{EN} = 5.5V$	Full		0.8	2	μA
	I_{BL}	$V_{EN} = 0V$	Full		0.01	1	
Shutdown Supply Current	I_{SHDN}	$V_{EN} = 0V$	Full		0.01	1	μA
Start-Up Time ⁽⁴⁾	t_{STR}	$C_{OUT} = 1\mu F$, No Load, $C_{BP} = 0\mu F$	$+25^{\circ}C$		30		μs
R_{ON} of Discharge MOSFET		$V_{IN} = 4.0V$, $V_{EN} = 0V$	$+25^{\circ}C$		50		Ω
THERMAL PROTECTION							
Thermal Shutdown Temperature	T_{SHDN}				140		$^{\circ}C$
Thermal Shutdown Hysteresis	ΔT_{SHDN}				15		$^{\circ}C$

NOTES:

- Maximum output current is affected by the PCB layout, size of metal trace, the thermal conduction path between metal layers, ambient temperature and the other environment factors of system. Attention should be paid to the dropout voltage when $V_{IN} < V_{OUT} + V_{DROP}$.
- The dropout voltage is defined as $V_{IN} - V_{OUT}$, when V_{OUT} is 100mV below the value of V_{OUT} .
- Output voltage temperature coefficient is defined as the worst-case voltage change divided by the total temperature range.
- Time needed for V_{OUT} to reach 90% of final value.

TYPICAL APPLICATION CIRCUIT

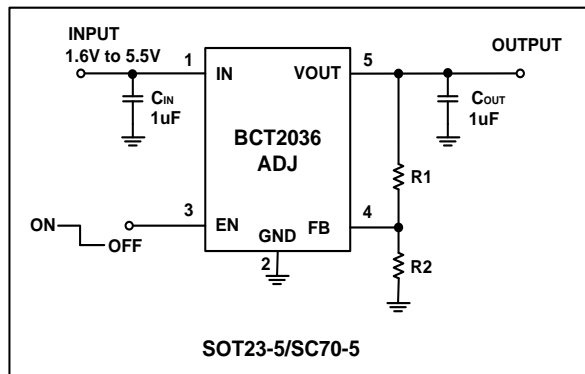
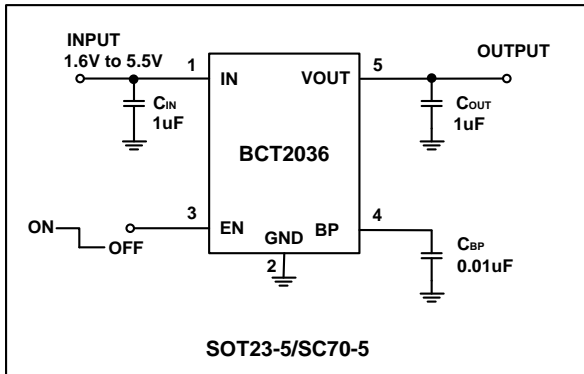
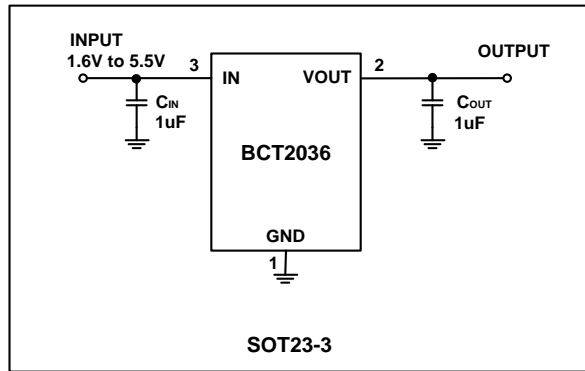
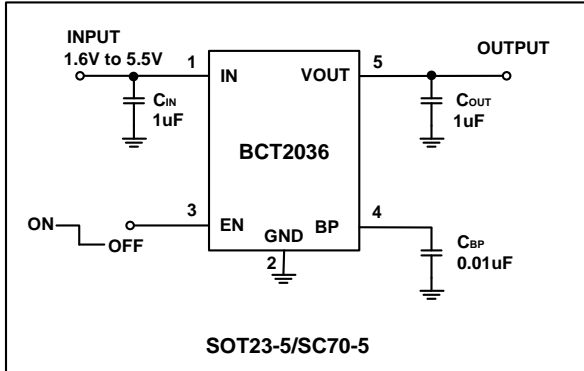

NOTES: Choose R2 = 160kΩ to maintain a 5μA minimum load.
Calculate the value for R1 using the following equation:

$$R_1 = R_2 \times \left(\frac{V_{OUT}}{0.8V} - 1 \right)$$

TYPICAL PERFORMANCE CHARACTERISTICS

$V_{EN} = V_{IN}$, $C_{IN} = 1\mu F$, $C_{OUT} = 1\mu F$, $C_{BP} = 0\mu F$, $T_A = +25^\circ C$, unless otherwise noted.

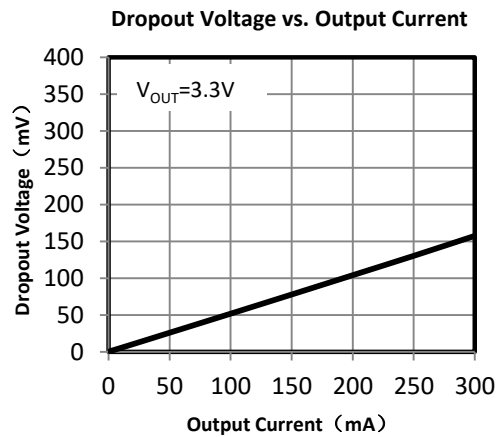
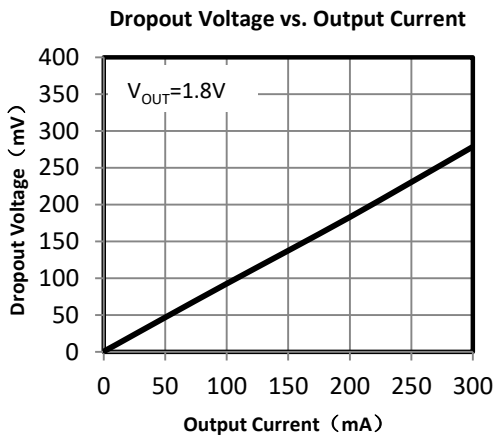
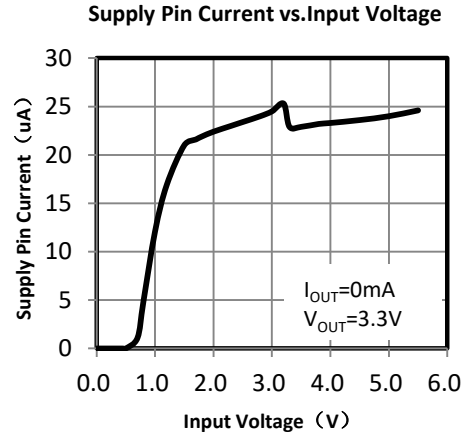
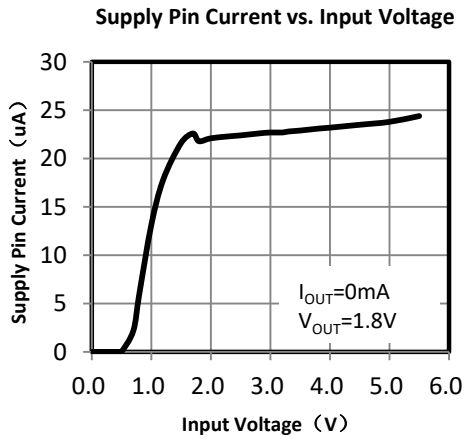
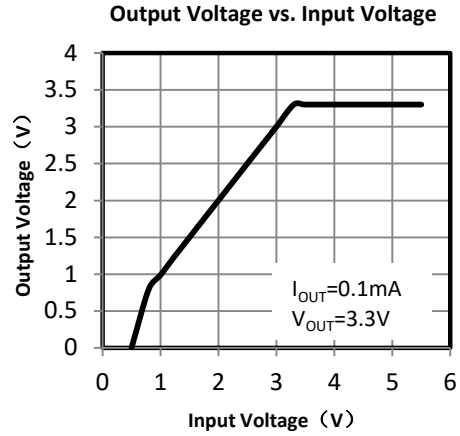
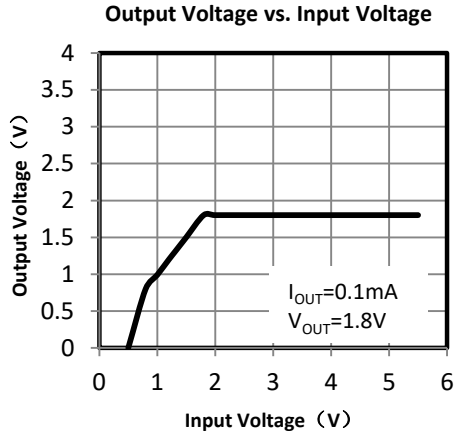

TYPICAL PERFORMANCE CHARACTERISTICS (continued)

$V_{EN} = V_{IN}$, $C_{IN} = 1\mu F$, $C_{OUT} = 1\mu F$, $C_{BP} = 0\mu F$, $T_A = +25^\circ C$, unless otherwise noted.

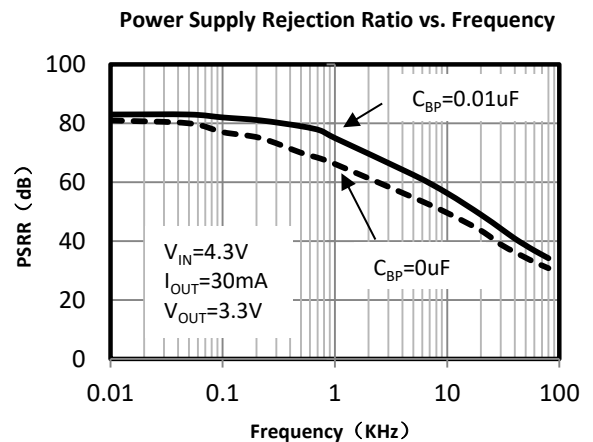
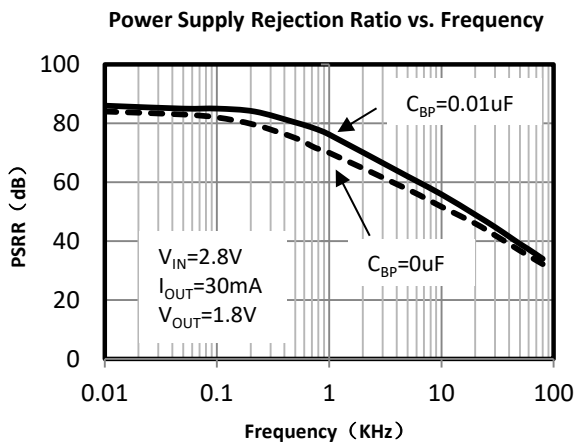
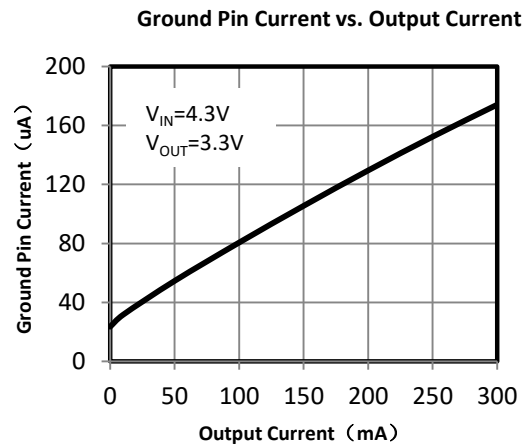
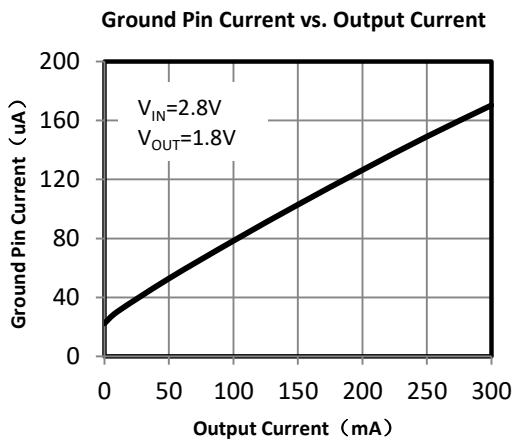
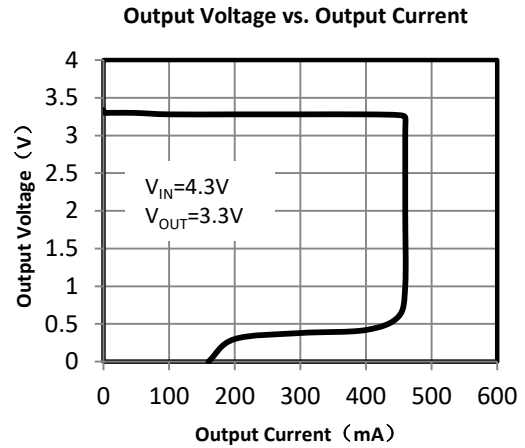
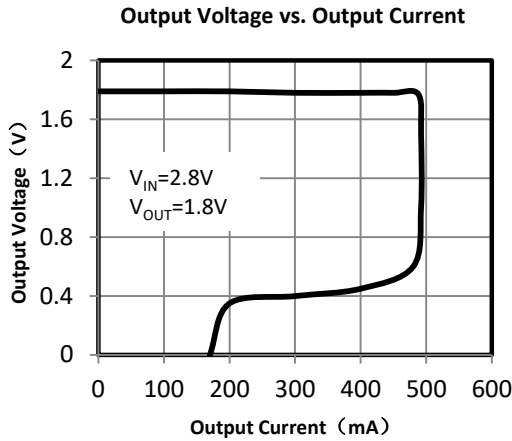

TYPICAL PERFORMANCE CHARACTERISTICS (continued)

$V_{EN} = V_{IN}$, $C_{IN} = 1\mu F$, $C_{OUT} = 1\mu F$, $C_{BP} = 0\mu F$, $T_A = +25^\circ C$, unless otherwise noted.

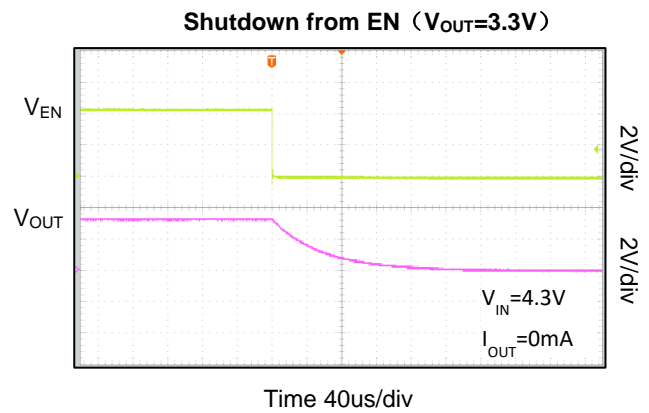
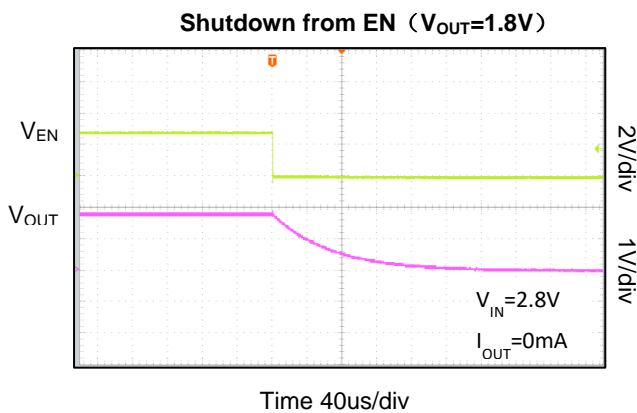
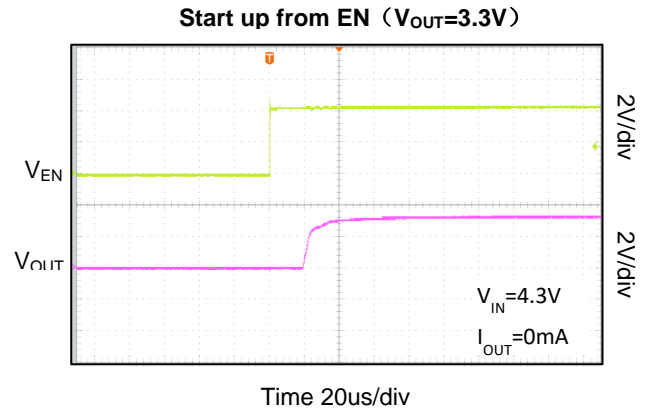
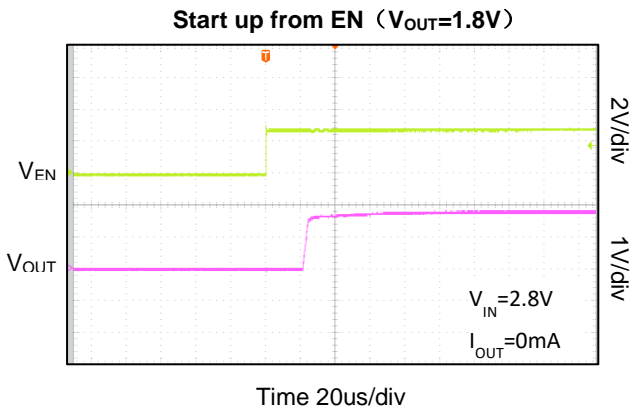
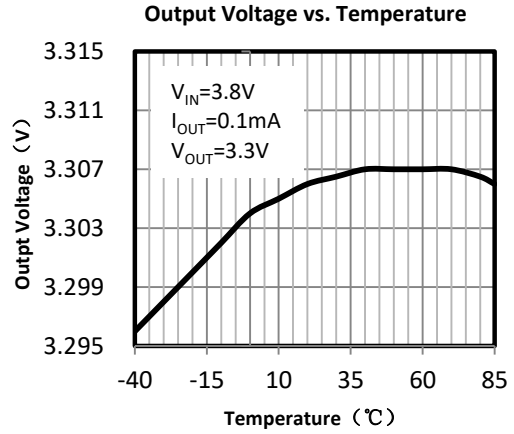
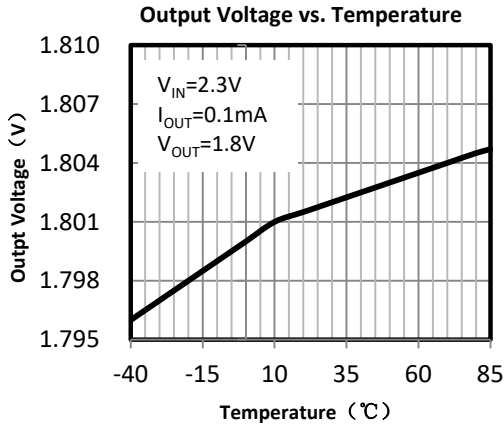

TYPICAL PERFORMANCE CHARACTERISTICS (continued)

$V_{EN} = V_{IN}$, $C_{IN} = 1\mu F$, $C_{OUT} = 1\mu F$, $C_{BP} = 0\mu F$, $T_A = +25^\circ C$, unless otherwise noted.

Line Transient Response ($V_{OUT}=1.8V$)

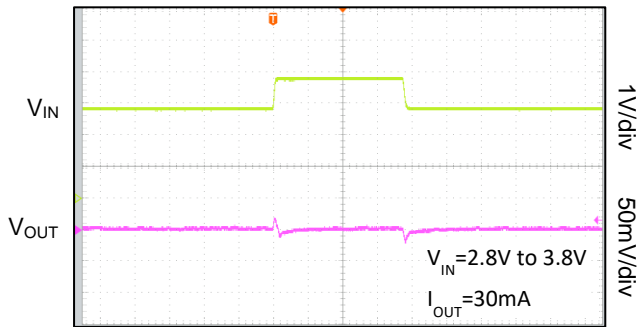

Time 40us/div

Line Transient Response ($V_{OUT}=3.3V$)

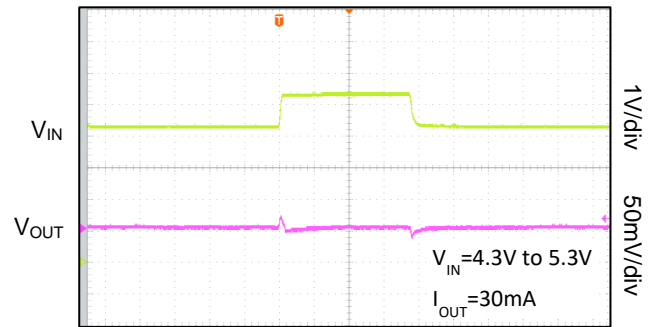

Time 40us/div

Load Transient Response ($V_{OUT}=1.8V$)

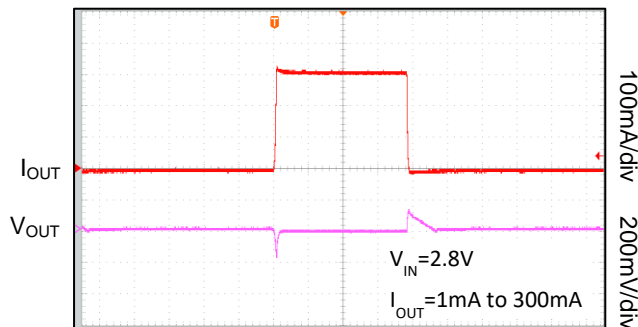

Time 100us/div

Load Transient Response ($V_{OUT}=3.3V$)

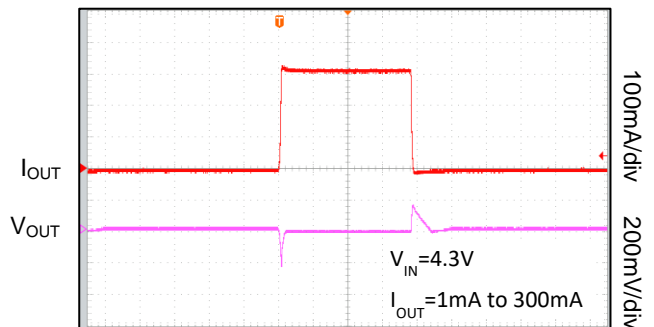

Time 100us/div

Load Transient Response ($V_{OUT}=1.8V$)

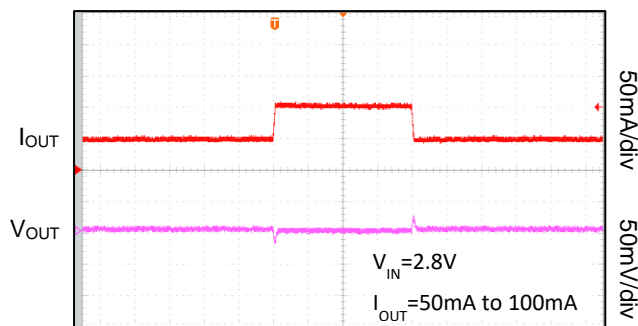

Time 100us/div

Load Transient Response ($V_{OUT}=3.3V$)

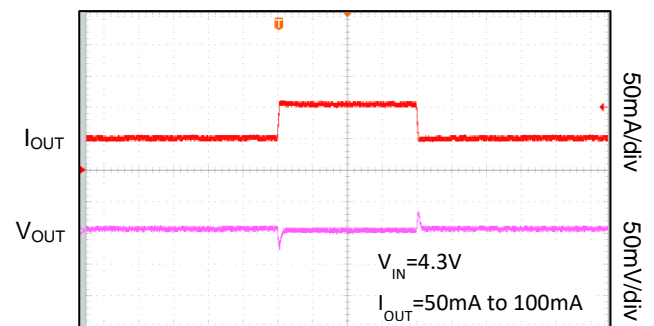

Time 100us/div

PACKAGE OUTLINE DIMENSIONS

SOT23-3

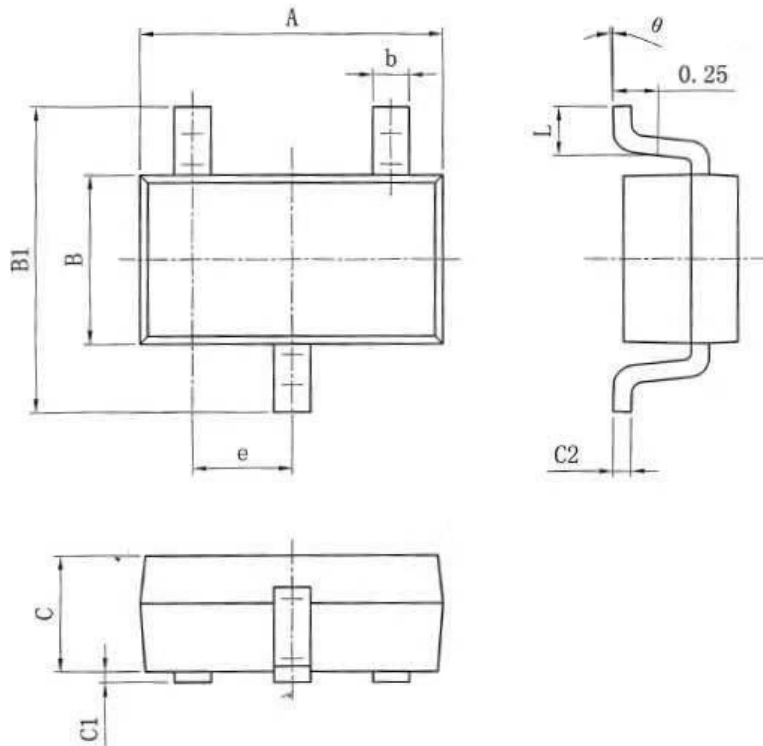

Symbol	Dimensions In Millimeters	
	Min	Max
A	2.82	3.02
e	0.95(BSC)	
b	0.28	0.45
B	1.50	1.70
B1	2.75	3.05
C	1.05	1.15
C1	0.03	0.15
C2	0.12	0.23
L	0.35	0.55
θ	0°	8°

SOT23-3 Surface Mount Package

SOT23-5

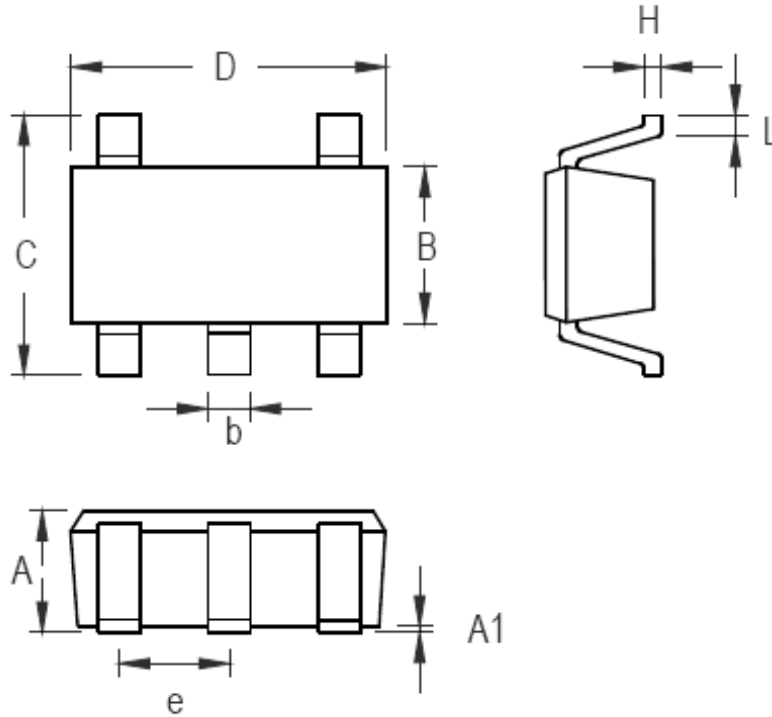

Symbol	Dimensions In Millimeters	
	Min	Max
A	1.05	1.15
A1	0.03	0.15
B	1.5	1.7
b	0.28	0.45
C	2.75	3.05
D	2.82	3.02
e	0.95(BSC)	
H	0.12	0.23
L	0.35	0.55

SOT23-5 Surface Mount Package

SC70-5

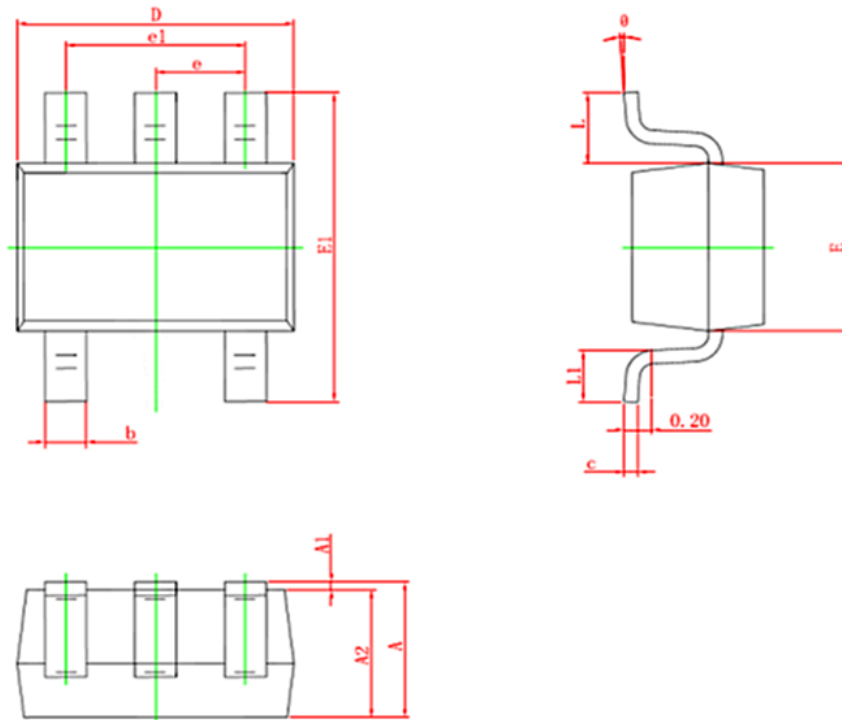

Symbol	Dimensions In Millimeters	
	Min.	Max.
A	0.900	1.100
A1	0.000	0.100
A2	0.900	1.000
b	0.150	0.350
c	0.110	0.175
D	2.000	2.200
E	1.150	1.350
E1	2.150	2.450
e	0.650 TYP.	
e1	1.200	1.400
L	0.525 REF.	
L1	0.260	0.460
θ	0°	8°

SC70-5 Surface Mount Package

UTDFN1x1-4L

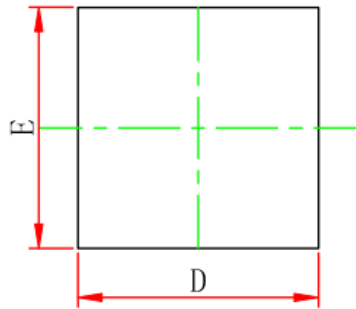

TOP VIEW

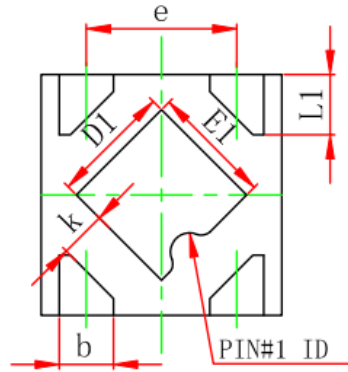

BOTTOM VIEW

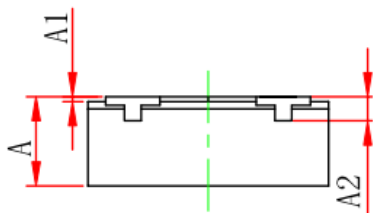

SIDE VIEW

Symbol	Dimensions In Millimeters	
	Min	Max
A	0.335	0.405
A1	0.000	0.050
A2	0.100 REF	
D	0.950	1.050
D1	0.450	0.550
E	0.950	1.050
E1	0.450	0.550
K	0.195 REF	
b	0.175	0.275
e	0.575	0.675
L	0.200	0.300

UTDFN1x1-4L Surface Mount Package

LAND PATTERN DATA

SOT23-5

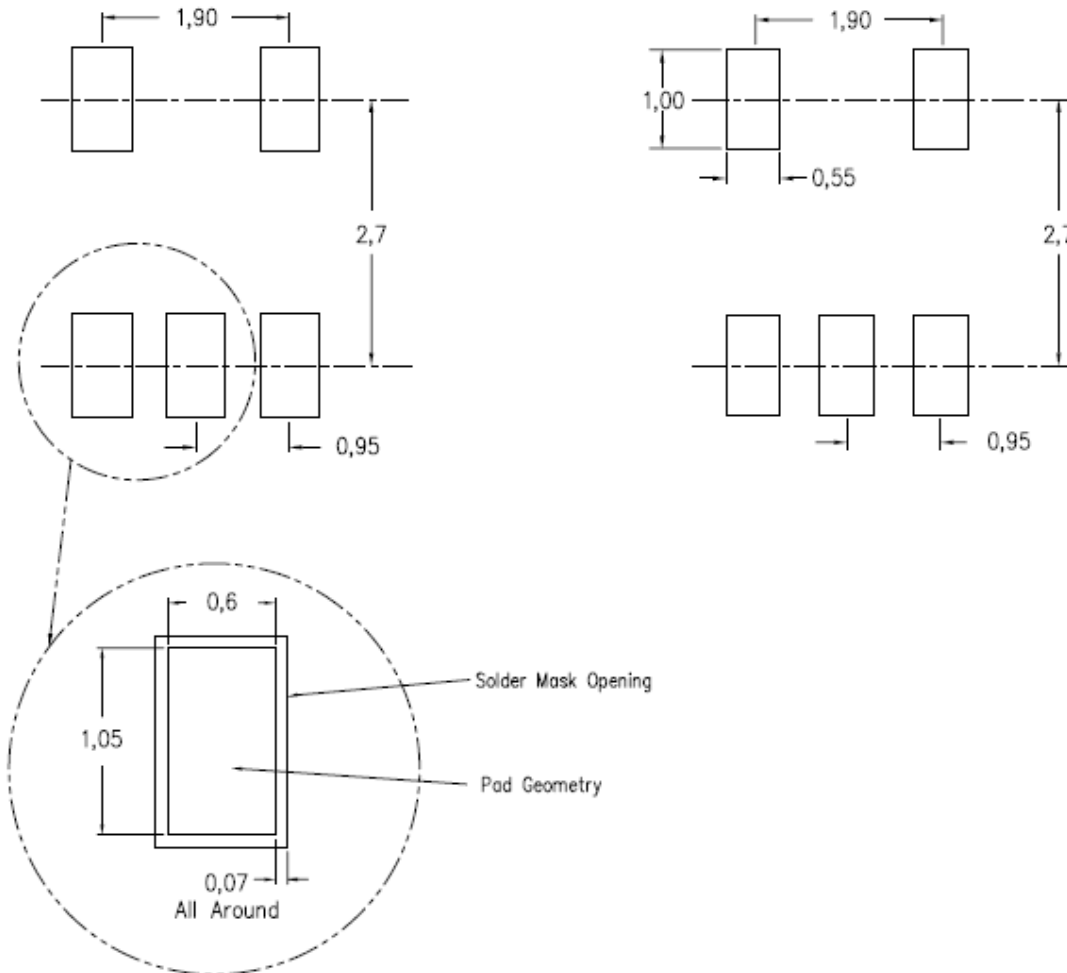

RECOMMENDED PCB LAYOUT PATTERN (Unit: mm)

SOT23-3

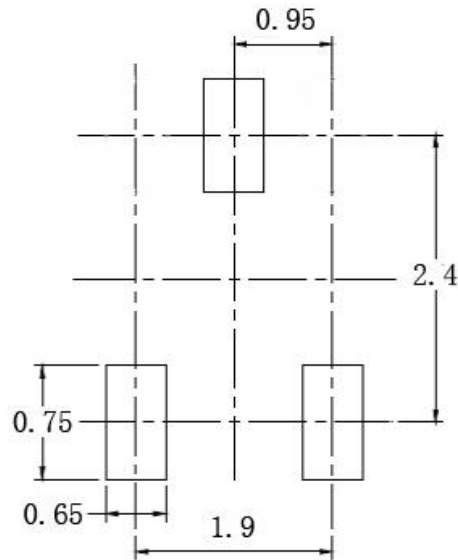

RECOMMENDED PCB LAYOUT PATTERN (Unit: mm)

SC70-5

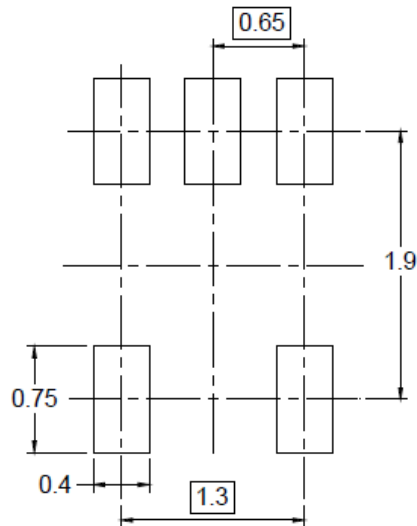

RECOMMENDED PCB LAYOUT PATTERN (Unit: mm)

UTDFN1x1-4L

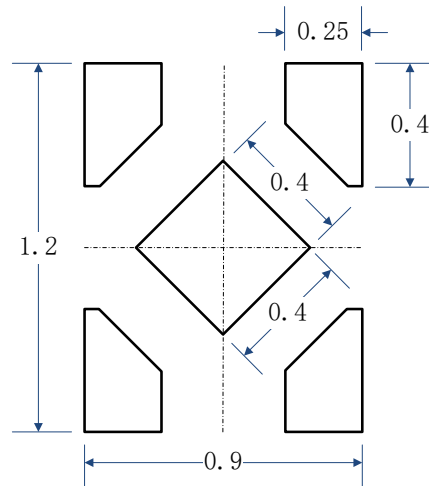

RECOMMENDED PCB LAYOUT PATTERN (Unit: mm)

X-ON Electronics

Largest Supplier of Electrical and Electronic Components

Click to view similar products for [Linear Voltage Regulators](#) category:

Click to view products by [BROADCHIP](#) manufacturer:

Other Similar products are found below :

[LV56831P-E](#) [LV5684PVD-XH](#) [MCDTSA6-2R](#) [L7815ACV-DG](#) [PQ3DZ53U](#) [LV56801P-E](#) [TLE42794G](#) [L78L05CZ/1SX](#) [L78LR05DL-MA-E](#) [636416C](#) [714954EB](#) [BA033LBSG2-TR](#) [LV5680P-E](#) [L78M15CV-DG](#) [TLS202B1MBV33HTSA1](#) [L79M05T-E](#) [TLS202A1MBVHTSA1](#) [L78LR05D-MA-E](#) [NCV317MBTG](#) [NTE7227](#) [LV5680NPVC-XH](#) [LT1054CN8](#) [MP2018GZD-5-Z](#) [MP2018GZD-33-Z](#) [MIC5281-3.3YMM](#) [MC78L06BP-AP](#) [TA48LS05F\(TE85L,F\)](#) [TA78L12F\(TE12L,F\)](#) [TC47BR5003ECT](#) [TCR2LN12,LF\(S](#) [TCR2LN28,LF\(S](#) [TCR2LN30,LF\(S](#) [TCR3DF295,LM\(CT](#) [TCR3DF40,LM\(CT](#) [BA178M20CP-E2](#) [L78M12ABDT](#) [LM7812SX/NOPB](#) [LR645N3-G-P003](#) [LR645N3-G-P013](#) [ZXTR2005P5-13](#) [SCD7812BTG](#) [TCR3DF335,LM\(CT](#) [ZXTR2012K-13](#) [TLE42994E V33](#) [ZXTR2008K-13](#) [ZXTR2005K-13](#) [LA5693D-E](#) [L88R05DL-E](#) [ADP3300ARTZ-2.7RL7](#) [LM120K-15/883](#)