



BCT2038

Low Power, Low Dropout RF-Linear Regulators

BCT2038

Low Power, Low Dropout, RF-Linear Regulators

GENERAL DESCRIPTION

The BCT2038 series low-power, low-dropout, CMOS linear voltage regulators operate from a 1.6V to 5.5V input voltage and deliver up to 500mA output current. They are the perfect choice for low voltage, low power applications. A low ground current makes this part attractive for battery operated power systems. The BCT2038 series also offer low dropout voltage to prolong battery life in portable electronics. Systems requiring a quiet voltage source, such as RF applications, will benefit from the BCT2038 series low output noise and high PSRR.

Other features include a 10nA logic-controlled shutdown mode, short current limit and thermal shutdown protection.

The BCT2038 has auto-discharge function to quickly discharge VOUT in the disable status.

The BCT2038 is available in Green SOT23-3, SOT23-5, SC70-5, SOT89-3 packages. It operates over an ambient temperature range of -40°C to +85°C .

FEATURES

- Low Dropout Voltage
- Thermal Overload Protection
- Built-In Fold Back Protection Circuit
- 20µA Low Supply Current
- 10nA Logic-Controlled Shutdown
- 1.6V to 5.5V Input Voltage Range
- Fixed Outputs of 1.2V, 1.8V, 2.8V, 3.0V, and 3.3V
- Adjustable Output from 0.8V to 5.0V
- Short Auto-Discharge Function
- 500mA Output Current
- High Output Voltage Accuracy
- Quick Start-Up Time
- -40°C to +85°C Operating Temperature Range Available in Green SOT23-3, SOT23-5, SC70-5, SOT89-3 Packages.

APPLICATIONS

Cellular Telephones
Cordless Telephones
PCMCIA Cards
Modems
MP3 Player
Hand-Held Instruments
Palmtop Computers
Electronic Planners
Portable/Battery-Powered Equipment



BCT2038

Low Power, Low Dropout RF-Linear Regulators

ORDERING INFORMATION

Order Number	V _{OUT} (V)	Package Type	Temperature Range	Marking	QTY/Reel
BCT2038EUR12-TR	1.2	SOT23-3	-40°C to +85°C	U2XX	3000
BCT2038EUR18-TR	1.8	SOT23-3	-40°C to +85°C	U8XX	3000
BCT2038EUR28-TR	2.8	SOT23-3	-40°C to +85°C	U8XX	3000
BCT2038EUR30-TR	3.0	SOT23-3	-40°C to +85°C	U0XX	3000
BCT2038EUR33-TR	3.3	SOT23-3	-40°C to +85°C	U3XX	3000
BCT2038EUK12-TR	1.2	SOT23-5	-40°C to +85°C	U2XX	3000
BCT2038EUK18-TR	1.8	SOT23-5	-40°C to +85°C	U8XX	3000
BCT2038EUK28-TR	2.8	SOT23-5	-40°C to +85°C	U8XX	3000
BCT2038EUK30-TR	3.0	SOT23-5	-40°C to +85°C	U0XX	3000
BCT2038EUK33-TR	3.3	SOT23-5	-40°C to +85°C	U3XX	3000
BCT2038EUKAJ-TR	ADJ	SOT23-5	-40°C to +85°C	UJXX	3000
BCT2038EXK12-TR	1.2	SC70-5	-40°C to +85°C	U2XX	3000
BCT2038EXK18-TR	1.8	SC70-5	-40°C to +85°C	U8XX	3000
BCT2038EXK28-TR	2.8	SC70-5	-40°C to +85°C	U8XX	3000
BCT2038EXK30-TR	3.0	SC70-5	-40°C to +85°C	U0XX	3000
BCT2038EXK33-TR	3.3	SC70-5	-40°C to +85°C	U3XX	3000
BCT2038EXKAJ-TR	ADJ	SC70-5	-40°C to +85°C	UJXX	3000
BCT2038EJR12-TR	1.2	SOT89-3	-40°C to +85°C	2038 12XXX	3000
BCT2038EJR18-TR	1.8	SOT89-3	-40°C to +85°C	2038 18XXX	3000
BCT2038EJR28-TR	2.8	SOT89-3	-40°C to +85°C	2038 28XXX	3000
BCT2038EJR30-TR	3.0	SOT89-3	-40°C to +85°C	2038 30XXX	3000
BCT2038EJR33-TR	3.3	SOT89-3	-40°C to +85°C	2038 33XXX	3000

Note:

"U in Marking is product short code for BCT2038

"XXX" in Marking will be appeared as the batch code.



BCT2038

Low Power, Low Dropout RF-Linear Regulators

ABSOLUTE MAXIMUM RATINGS

IN to GND.....	-0.3V to 6.0V
Output Short-Circuit Duration.....	Infinite
EN to GND.....	-0.3V to 6.0V
OUT,BP/FB to GND.....	-0.3V to (VIN +0.3V)
Power Dissipation, P _D @T _A =25°C	
SOT23-3.....	0.42W
SOT23-5.....	0.48W
SC70-5.....	0.38W
SOT89-3.....	1.25W
Package Thermal Resistance	
SOT23-3.....	300°C/W
SOT23-5, θ _{JA}	260°C/W
SC70-5, θ _{JA}	330°C/W
SOT89-3, θ _{JA}	100°C/W
Junction Temperature.....	150°C
Storage Temperature Range.....	-65°C to 150°C
Lead Temperature (Soldering, 10 sec).....	260°C
ESD Susceptibility	
HBM.....	4000V
MM.....	400V

RECOMMENDED OPERATING CONDITIONS

Operating Voltage Range.....	1.6V to 5.5V
Operating Temperature Range	-40°C to +85°C

OVERSTRESS CAUTION

Stresses beyond those listed under “Absolute Maximum Ratings” may cause permanent damage to the device. These are stress ratings only, and functional operation of the device at these or any other conditions beyond those indicated in the operational sections of the specifications is not implied. Exposure to absolute maximum rating conditions for extended periods may affect device reliability.

ESD SENSITIVITY CAUTION

This integrated circuit can be damaged by ESD if you don't pay attention to ESD protection. Broadchip recommends that all integrated circuits be handled with appropriate precautions. Failure to observe proper handling and installation procedures can cause damage. ESD damage can range from subtle performance degradation to complete device failure. Precision integrated circuits may be more susceptible to damage because very small parametric changes could cause the device not to meet its published specifications.

DISCLAIMER

Broadchip reserves the right to make any change in circuit design, specification or other related things if necessary without notice at any time. Please contact Broadchip sales office to get the latest datasheet.

PIN CONFIGURATION (TOP VIEW)

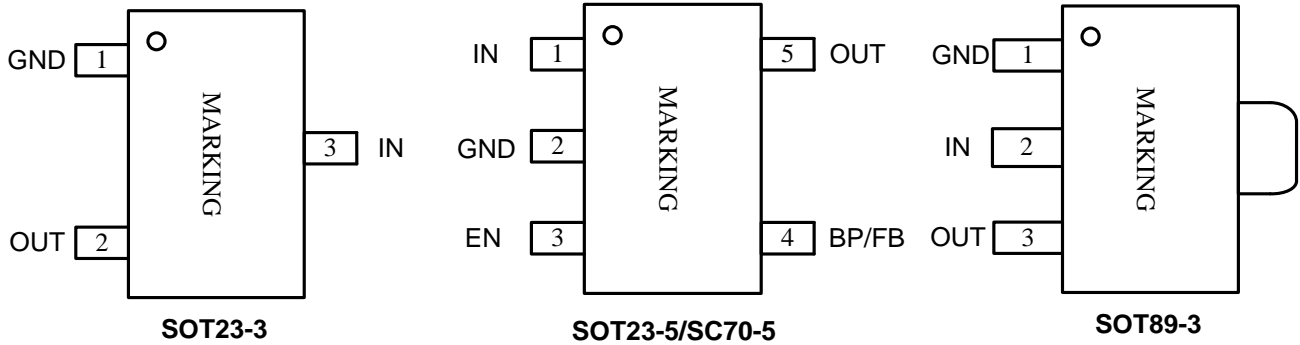

PIN DESCRIPTION

PIN			NAME	FUNCTION
SOT23-3	SOT23-5 SC70-5	SOT89-3		
1	2	1	GND	Ground.
2	5	3	OUT	Regulator Output.
3	1	2	IN	Regulator Input. Supply voltage can range from 1.6V to 5.5V. Bypass with a 1 μ F capacitor to GND.
-	3	-	EN	Enable Pin. This pin has an internal pull-down resistor. A logic low reduces the supply current to less than 1 μ A. Connect to IN for normal operation.
-	4	-	BP	Reference-Noise Bypass Pin (fixed voltage version only). Bypass with a low-leakage 0.01 μ F ceramic capacitor for reduced noise at the output. The capacitor is recommended to be placed very close to the pin for high PSRR.
-			FB	Adjustable Voltage Version Only. This is used to set the output voltage of the device.

ELECTRICAL CHARACTERISTICS

($V_{IN} = V_{OUT(NOMINAL)} + 0.5V$ or $1.6V$, whichever is greater, Full = $-40^{\circ}C$ to $+85^{\circ}C$, unless otherwise noted.)

PARAMETER	SYMBOL	CONDITIONS	TEMP	MIN	TYP	MAX	UNITS
Input Voltage	V_{IN}		$+25^{\circ}C$	1.6		5.5	V
Output Voltage Accuracy		$I_{OUT} = 0.1mA$	$+25^{\circ}C$	-2.5		+2.5	%
Feedback Voltage	V_{FB}	$I_{OUT} = 0.1mA$, BCT2038-ADJ	$+25^{\circ}C$	0.78	0.8	0.82	V
Maximum Output Current (1)			$+25^{\circ}C$	500			mA
Current Limit	I_{LIM}		$+25^{\circ}C$	560	800		mA
Ground Pin Current	I_Q	No Load, $V_{EN} = V_{IN}$	$+25^{\circ}C$		20	26	μA
Dropout Voltage (2)	V_{DROP}	$I_{OUT} = 500mA$	$1.2V \leq V_{OUT} < 1.8V$	$+25^{\circ}C$	945	1280	mV
			$1.8V \leq V_{OUT} < 2.5V$	$+25^{\circ}C$	510	670	
			$2.5V \leq V_{OUT} < 3.0V$	$+25^{\circ}C$	345	450	
			$3.0V \leq V_{OUT} < 3.6V$	$+25^{\circ}C$	305	400	
Line Regulation	$\frac{\Delta V_{OUT}}{\Delta V_{IN} \times V_{OUT}}$	$V_{IN} = 1.6V$ or ($V_{OUT} + 0.5V$) to $5.5V$, $I_{OUT} = 1mA$	$1.8V \leq V_{OUT} \leq 3.3V$	$+25^{\circ}C$	0.01	0.06	%V
			$V_{OUT} < 1.8V$ or $V_{OUT} > 3.3V$	$+25^{\circ}C$	0.01	0.1	
Load Regulation	ΔV_{OUT}	$I_{OUT} = 0.1mA$ to $500mA$	$+25^{\circ}C$		12	40	mV
Short Current Limit	I_{SHORT}	$V_{OUT} = 0V$	$+25^{\circ}C$		320		mA
Power Supply Rejection Ratio	PSRR	$C_{BP} = 0\mu F$, $I_{OUT} = 30mA$, $C_{OUT} = 1\mu F$, $V_{IN} = 2.8V$, $V_{OUT} = 1.8V$, $\Delta V_{RIPPLE} = 0.2V_{P-P}$	$f = 217Hz$	$+25^{\circ}C$	80		dB
			$f = 1kHz$	$+25^{\circ}C$	70		
		$C_{BP} = 0.01\mu F$, $I_{OUT} = 30mA$, $C_{OUT} = 1\mu F$, $V_{IN} = 2.8V$, $V_{OUT} = 1.8V$, $\Delta V_{RIPPLE} = 0.2V_{P-P}$	$f = 217Hz$	$+25^{\circ}C$	82		
			$f = 1kHz$	$+25^{\circ}C$	75		
Output Voltage Noise	e_n	$C_{BP} = 0\mu F$, $f = 10Hz$ to $100kHz$, $C_{OUT} = 1\mu F$, $V_{IN} = 2.8V$, $V_{OUT} = 1.8V$	$I_{OUT} = 0mA$	$+25^{\circ}C$	70		μV_{RMS}
			$I_{OUT} = 30mA$	$+25^{\circ}C$	100		
		$C_{BP} = 0.01\mu F$, $f = 10Hz$ to $100kHz$, $C_{OUT} = 1\mu F$, $V_{IN} = 2.8V$, $V_{OUT} = 1.8V$	$I_{OUT} = 0mA$	$+25^{\circ}C$	25		
			$I_{OUT} = 30mA$	$+25^{\circ}C$	65		
Output Voltage Temperature Coefficient (3)	$\frac{\Delta V_{OUT}}{\Delta T_A \times V_{OUT}}$	$I_{OUT} = 0.1mA$	Full		30		ppm/ $^{\circ}C$



BCT2038

Low Power, Low Dropout RF-Linear Regulators

ELECTRICAL CHARACTERISTICS

($V_{IN} = V_{OUT(NOMINAL)} + 0.5V$ or $1.6V$, whichever is greater, Full = $-40^{\circ}C$ to $+85^{\circ}C$, unless otherwise noted.)

PARAMETER	SYMBOL	CONDITIONS	TEMP	MIN	TYP	MAX	UNITS
SHUTDOWN							
EN Input Threshold	V_{IH}	$V_{IN} = 1.6V$ to $5.5V$	Full	1.5			V
	V_{IL}		Full			0.4	
EN Input Bias Current	I_{BH}	$V_{EN} = 5.5V$	Full		0.8	2	μA
	I_{BL}	$V_{EN} = 0V$	Full		0.01	1	
Shutdown Supply Current	I_{SHDN}	$V_{EN} = 0V$	Full		0.01	1	μA
Start-Up Time ⁽⁴⁾	t_{STR}	$C_{OUT} = 1\mu F$, No Load, $C_{BP} = 0\mu F$	$+25^{\circ}C$		30		μs
R_{ON} of Discharge MOSFET		$V_{IN} = 4.0V$, $V_{EN} = 0V$	$+25^{\circ}C$		50		Ω
THERMAL PROTECTION							
Thermal Shutdown Temperature	T_{SHDN}				140		$^{\circ}C$
Thermal Shutdown Hysteresis	ΔT_{SHDN}				15		$^{\circ}C$

NOTES:

- Maximum output current is affected by the PCB layout, size of metal trace, the thermal conduction path between metal layers, ambient temperature and the other environment factors of system. Attention should be paid to the dropout voltage when $V_{IN} < V_{OUT} + V_{DROP}$.
- The dropout voltage is defined as $V_{IN} - V_{OUT}$, when V_{OUT} is 100mV below the value of V_{OUT} .
- Output voltage temperature coefficient is defined as the worst-case voltage change divided by the total temperature range.
- Time needed for V_{OUT} to reach 90% of final value.

TYPICAL APPLICATION CIRCUIT

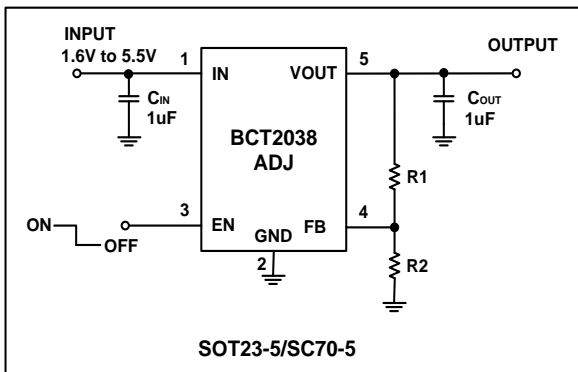
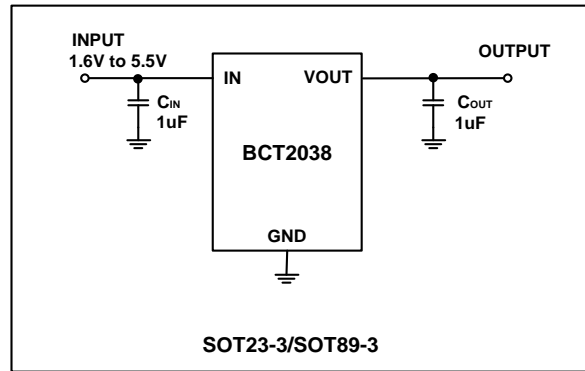
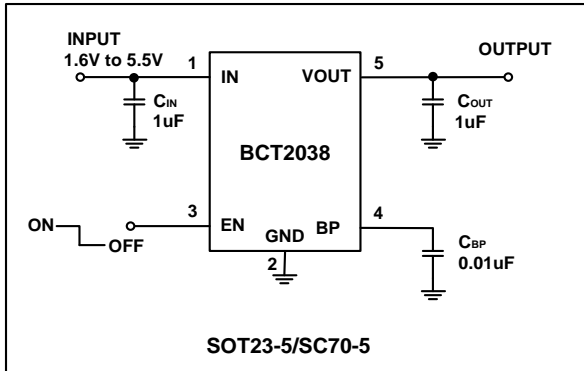

NOTES: Choose R2 = 160kΩ to maintain a 5μA minimum load.
Calculate the value for R1 using the following equation:

$$R_1 = R_2 \times \left(\frac{V_{OUT}}{0.8V} - 1 \right)$$

TYPICAL PERFORMANCE CHARACTERISTICS

$V_{EN} = V_{IN}$, $C_{IN} = 1\mu F$, $C_{OUT} = 1\mu F$, $C_{BP} = 0\mu F$, $T_A = +25^\circ C$, unless otherwise noted.

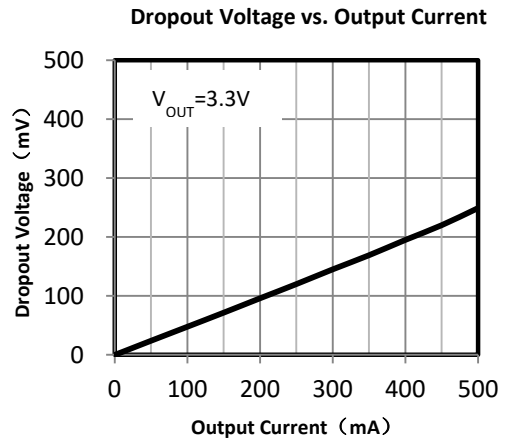
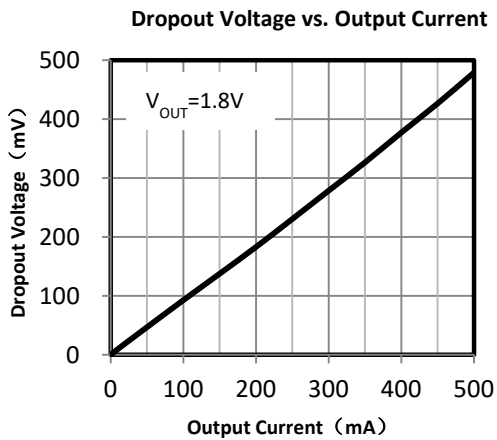
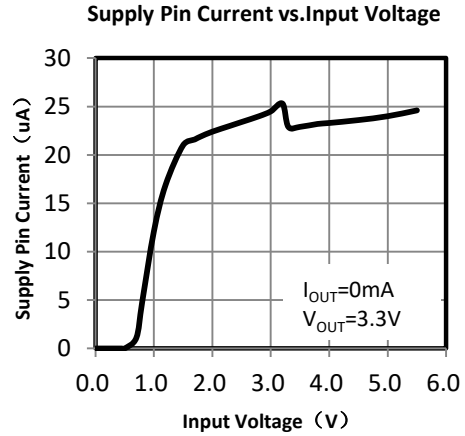
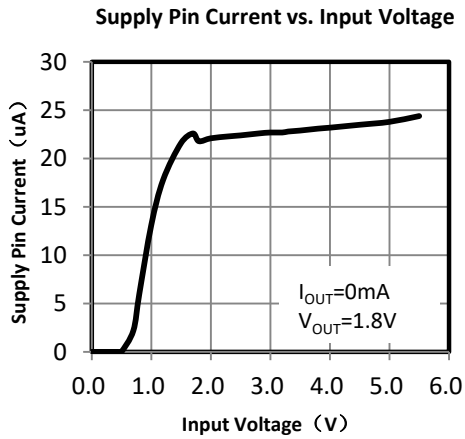
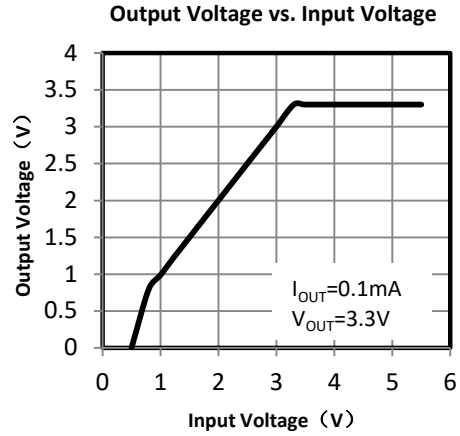
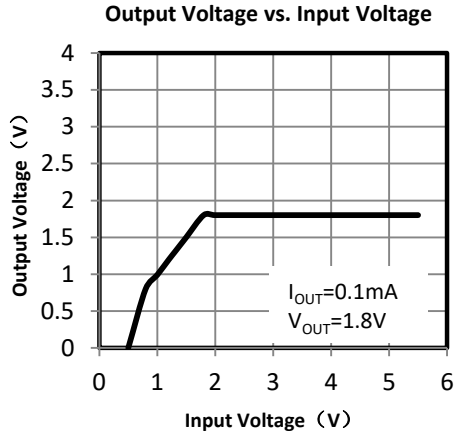

TYPICAL PERFORMANCE CHARACTERISTICS (continued)

$V_{EN} = V_{IN}$, $C_{IN} = 1\mu F$, $C_{OUT} = 1\mu F$, $C_{BP} = 0\mu F$, $T_A = +25^\circ C$, unless otherwise noted.

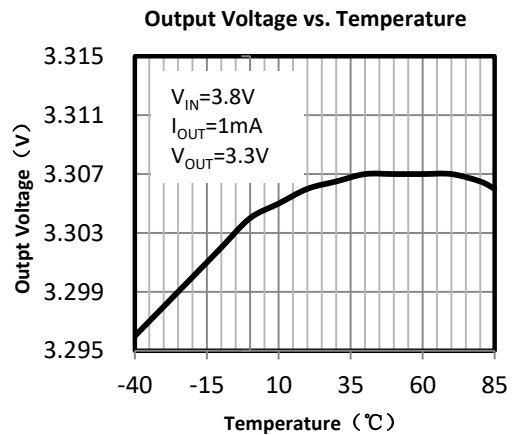
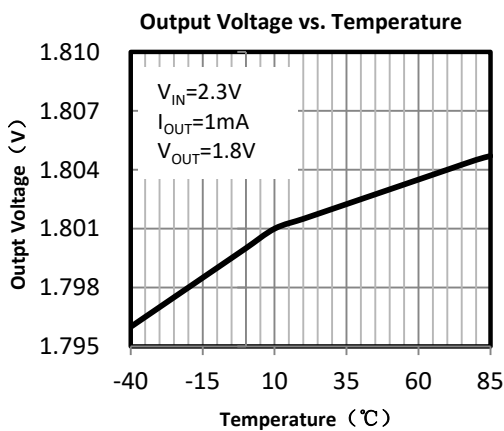
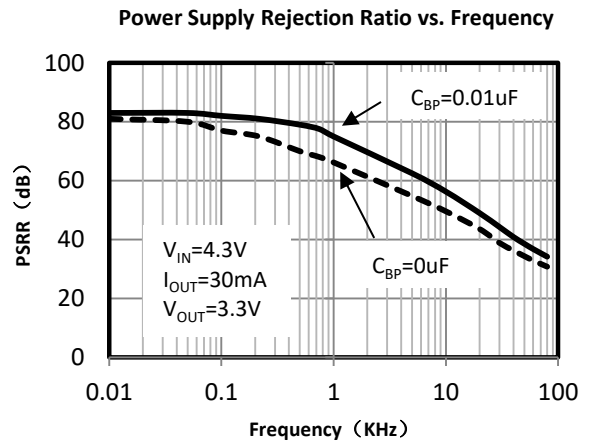
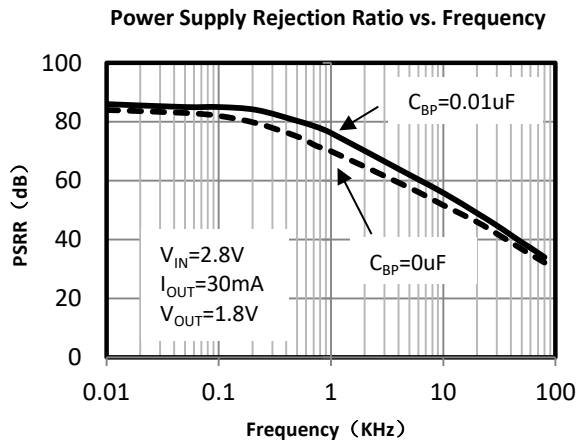
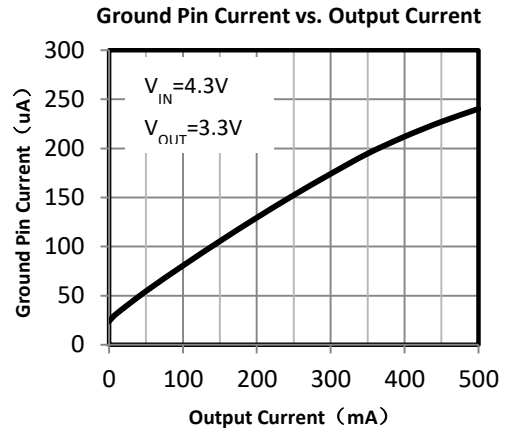
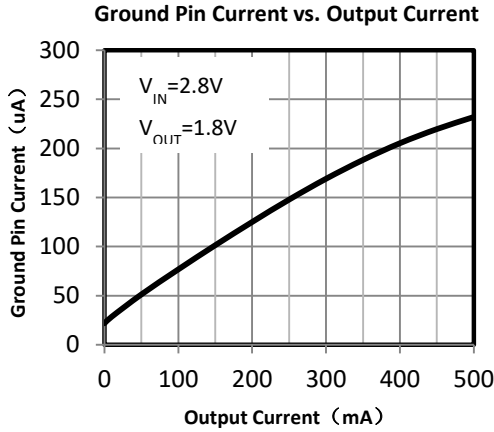

TYPICAL PERFORMANCE CHARACTERISTICS (continued)

$V_{EN} = V_{IN}$, $C_{IN} = 1\mu F$, $C_{OUT} = 1\mu F$, $C_{BP} = 0\mu F$, $T_A = +25^\circ C$, unless otherwise noted.

Start up from EN ($V_{OUT}=1.8V$)

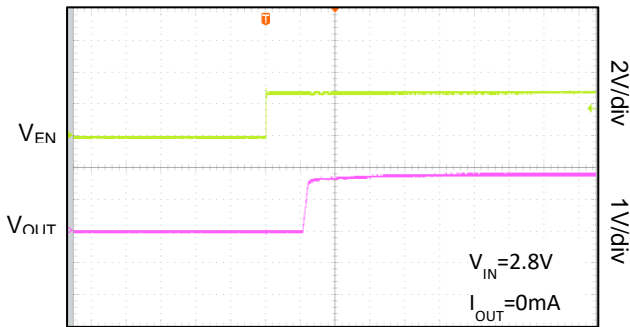

Time 20us/div

Start up from EN ($V_{OUT}=3.3V$)

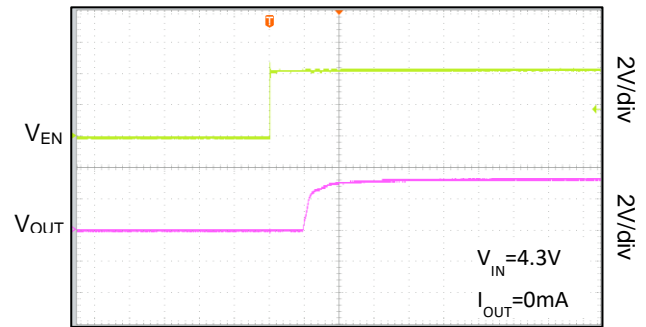

Time 20us/div

Shutdown from EN ($V_{OUT}=1.8V$)

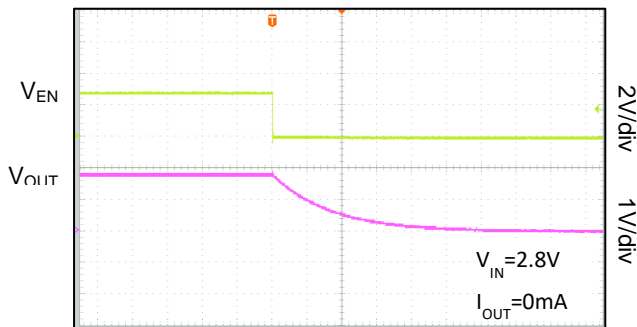

Time 40us/div

Shutdown from EN ($V_{OUT}=3.3V$)

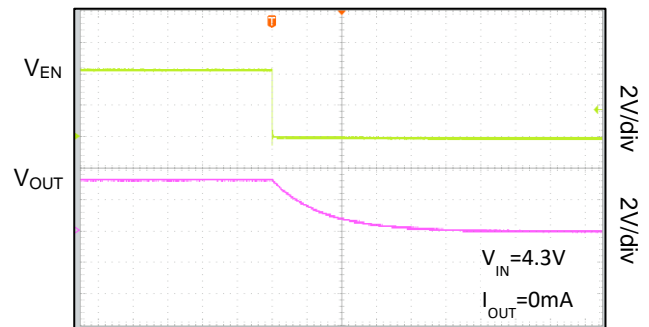

Time 40us/div

TYPICAL PERFORMANCE CHARACTERISTICS (continued)

$V_{EN} = V_{IN}$, $C_{IN} = 1\mu F$, $C_{OUT} = 1\mu F$, $C_{BP} = 0\mu F$, $T_A = +25^\circ C$, unless otherwise noted.

Line Transient Response ($V_{OUT}=1.8V$)

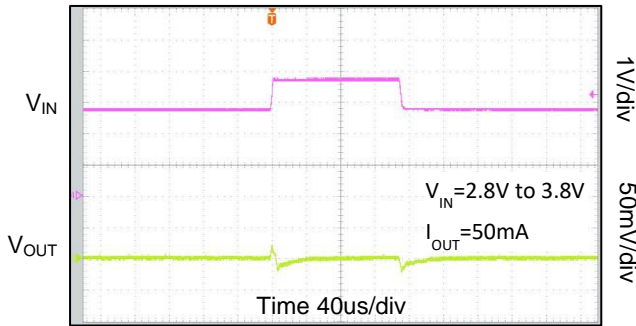

Line Transient Response ($V_{OUT}=3.3V$)

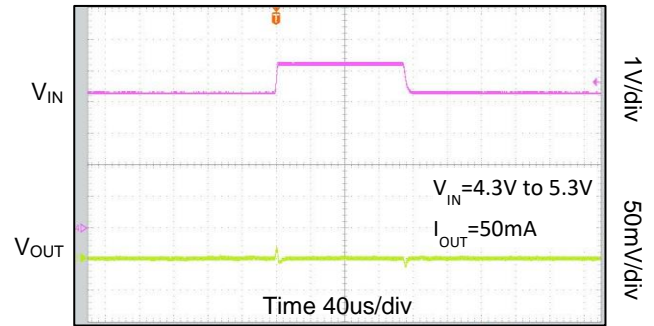

Load Transient Response ($V_{OUT}=1.8V$)

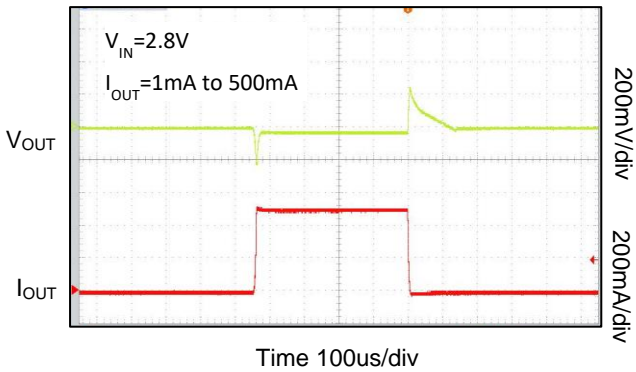

Load Transient Response ($V_{OUT}=3.3V$)

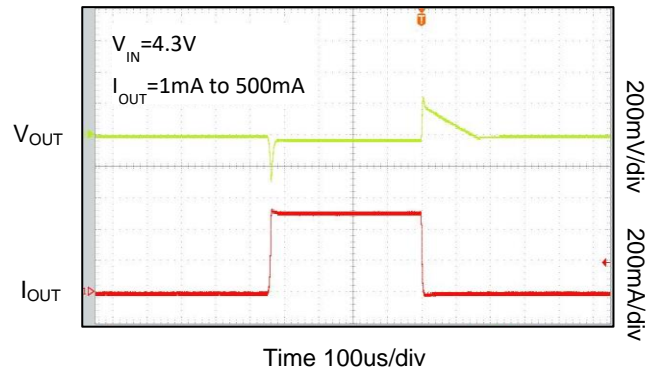

Load Transient Response ($V_{OUT}=1.8V$)

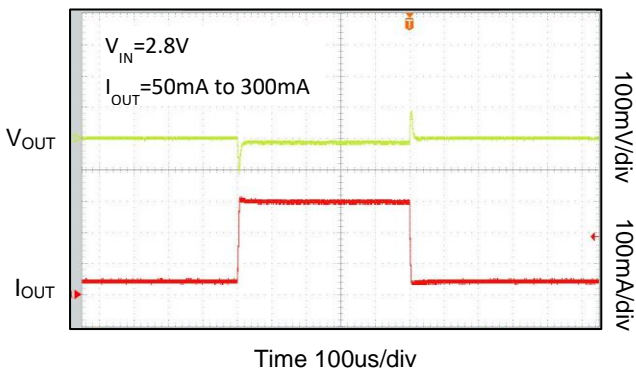

Load Transient Response ($V_{OUT}=3.3V$)

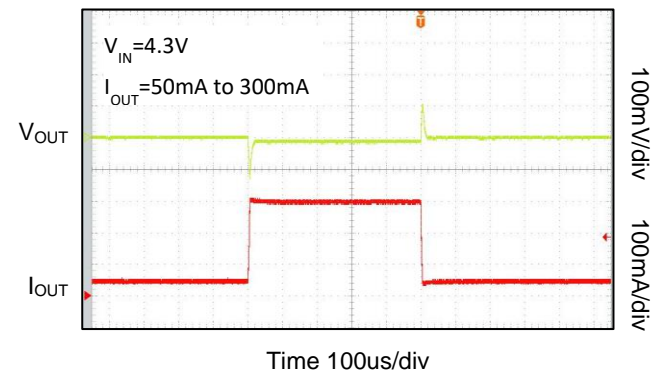

PACKAGE OUTLINE DIMENSIONS

SOT23-3

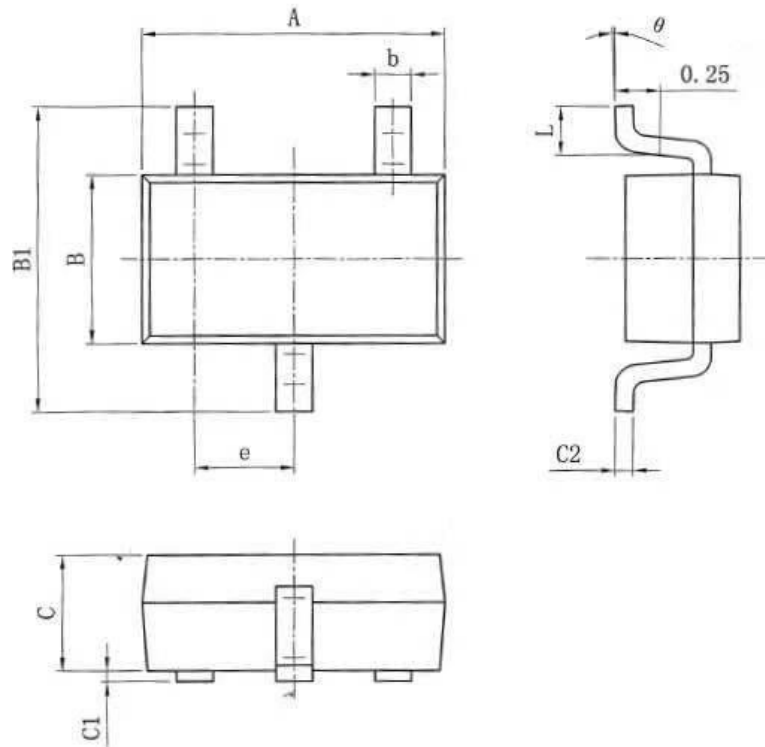

Symbol	Dimensions In Millimeters	
	Min	Max
A	2.82	3.02
e	0.95(BSC)	
b	0.28	0.45
B	1.50	1.70
B1	2.75	3.05
C	1.05	1.15
C1	0.03	0.15
C2	0.12	0.23
L	0.35	0.55
θ	0°	8°

SOT23-3 Surface Mount Package

SOT23-5

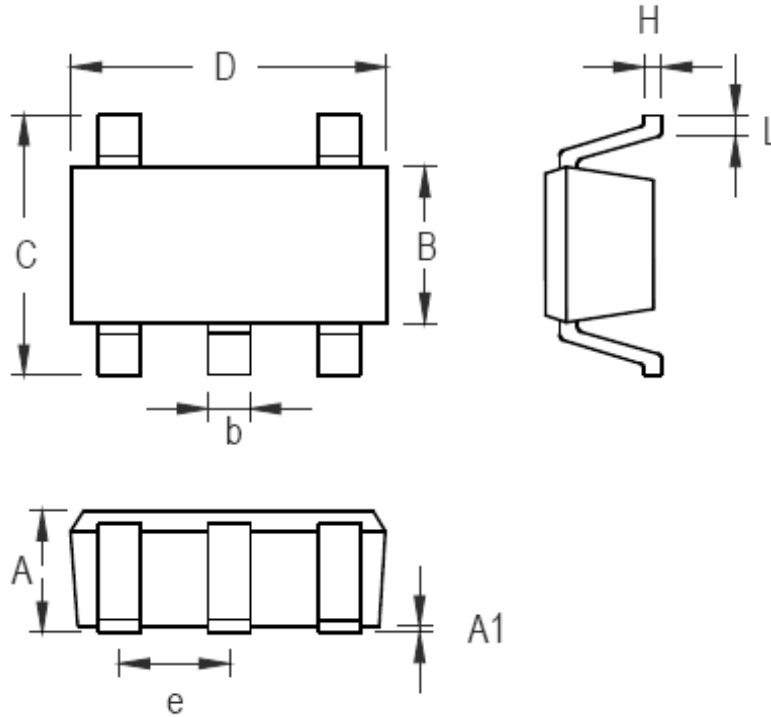

Symbol	Dimensions In Millimeters	
	Min	Max
A	1.05	1.15
A1	0.03	0.15
B	1.5	1.7
b	0.28	0.45
C	2.75	3.05
D	2.82	3.02
e	0.95(BSC)	
H	0.12	0.23
L	0.35	0.55

SOT23-5 Surface Mount Package

SC70-5

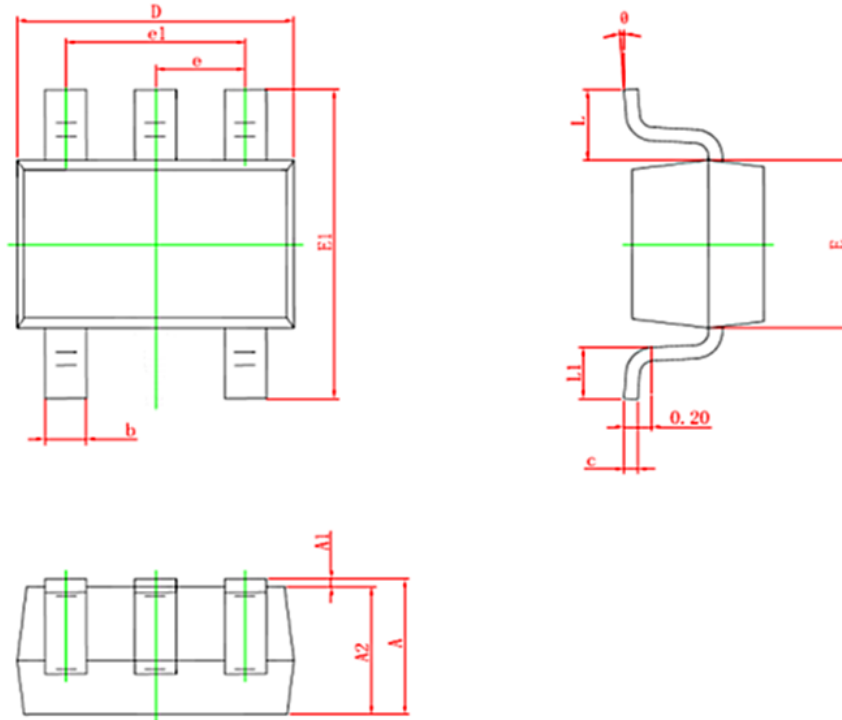

Symbol	Dimensions In Millimeters	
	Min.	Max.
A	0.900	1.100
A1	0.000	0.100
A2	0.900	1.000
b	0.150	0.350
c	0.110	0.175
D	2.000	2.200
E	1.150	1.350
E1	2.150	2.450
e	0.650 TYP.	
e1	1.200	1.400
L	0.525 REF.	
L1	0.260	0.460
θ	0°	8°

SC70-5 Surface Mount Package

SOT89-3

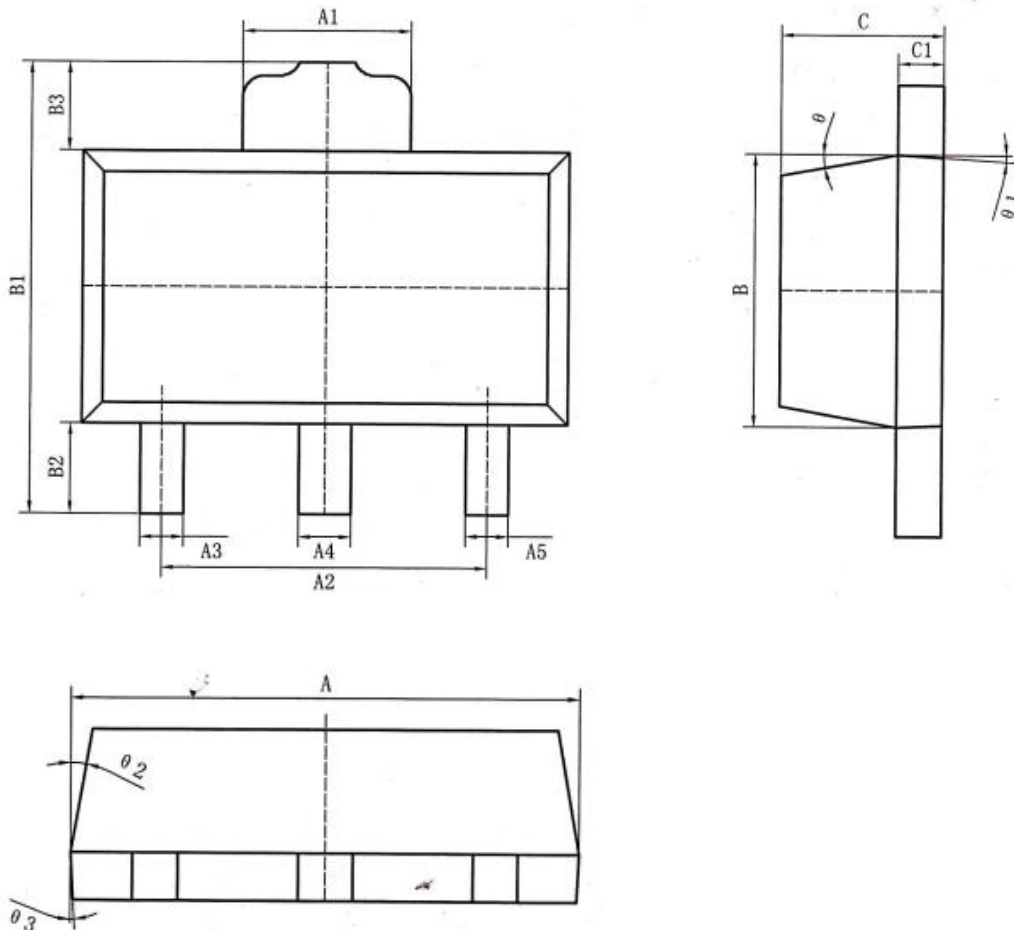

标注	尺寸	最小 (mm)	最大 (mm)	标注	尺寸	最小 (mm)	最大 (mm)
A		4.40	4.60	B3		0.82	0.83
A1		1.65	1.75	C		1.40	1.60
A2		2.95	3.05	C1		0.35	0.45
A3		0.35	0.45	theta		6° TYP4	
A4		0.43	0.53	theta 1		3° TYP4	
A5		0.35	0.45	theta 2		6° TYP4	
B		2.40	2.60	theta 3		3° TYP4	
B1		4.05	4.25				
B2		0.82	0.83				

SOT89-3 Surface Mount Package

LAND PATTERN DATA

SOT23-5

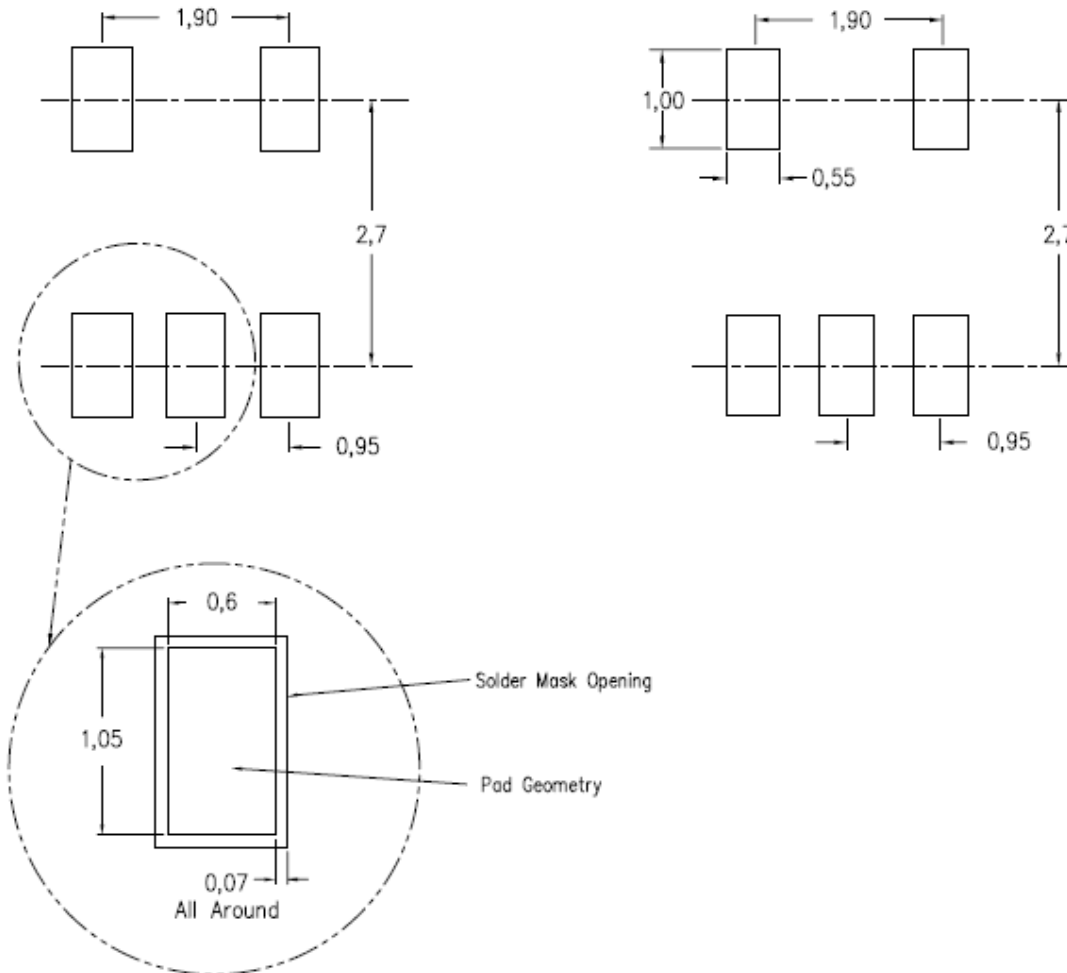

RECOMMENDED PCB LAYOUT PATTERN (Unit: mm)

SOT23-3

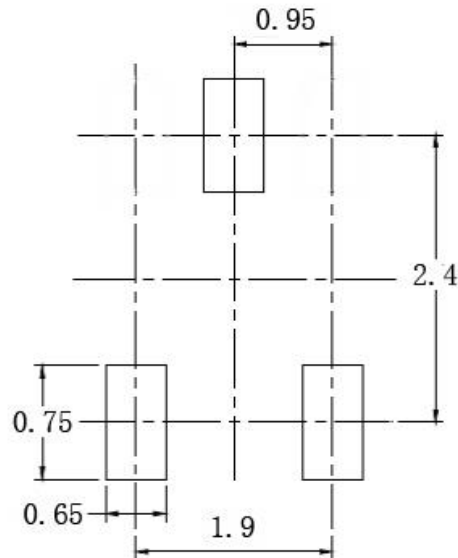

RECOMMENDED PCB LAYOUT PATTERN (Unit: mm)

SC70-5

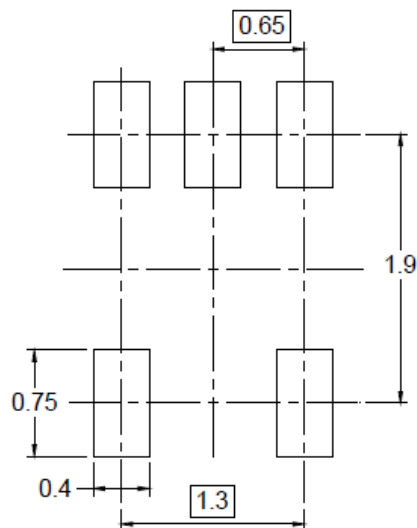

RECOMMENDED PCB LAYOUT PATTERN (Unit: mm)

SOT89-3

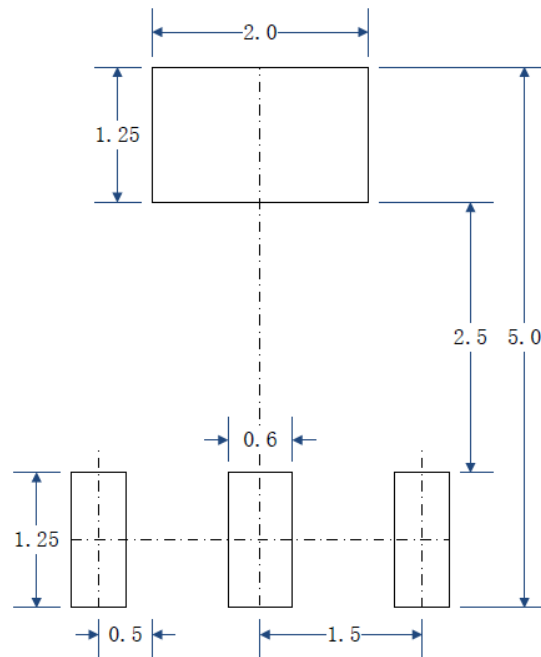

RECOMMENDED PCB LAYOUT PATTERN (Unit: mm)

X-ON Electronics

Largest Supplier of Electrical and Electronic Components

Click to view similar products for [Linear Voltage Regulators](#) category:

Click to view products by [BROADCHIP](#) manufacturer:

Other Similar products are found below :

[LV56831P-E](#) [LV5684PVD-XH](#) [MCDTSA6-2R](#) [L7815ACV-DG](#) [PQ3DZ53U](#) [LV56801P-E](#) [TLE42794G](#) [L78L05CZ/1SX](#) [L78LR05DL-MA-E](#) [636416C](#) [714954EB](#) [BA033LBSG2-TR](#) [LV5680P-E](#) [L78M15CV-DG](#) [TLS202B1MBV33HTSA1](#) [L79M05T-E](#) [TLS202A1MBVHTSA1](#) [L78LR05D-MA-E](#) [NCV317MBTG](#) [NTE7227](#) [LV5680NPVC-XH](#) [LT1054CN8](#) [MP2018GZD-5-Z](#) [MP2018GZD-33-Z](#) [MIC5281-3.3YMM](#) [MC78L06BP-AP](#) [TA48LS05F\(TE85L,F\)](#) [TA78L12F\(TE12L,F\)](#) [TC47BR5003ECT](#) [TCR2LN12,LF\(S](#) [TCR2LN28,LF\(S](#) [TCR2LN30,LF\(S](#) [TCR3DF295,LM\(CT](#) [TCR3DF40,LM\(CT](#) [BA178M20CP-E2](#) [L78M12ABDT](#) [LM7812SX/NOPB](#) [LR645N3-G-P003](#) [LR645N3-G-P013](#) [ZXTR2005P5-13](#) [SCD7812BTG](#) [TCR3DF335,LM\(CT](#) [ZXTR2012K-13](#) [TLE42994E V33](#) [ZXTR2008K-13](#) [ZXTR2005K-13](#) [LA5693D-E](#) [L88R05DL-E](#) [ADP3300ARTZ-2.7RL7](#) [LM120K-15/883](#)