



BCT2040

1A, Low Dropout, Linear Regulators

BCT2040

1A Low Dropout Linear Regulators

GENERAL DESCRIPTION

The BCT2040 series low-power, low-noise, low-dropout, CMOS linear voltage regulators operate from a 2.2V to 6.0V input voltage. They are the perfect choice for low voltage, low power applications. A low ground current makes this part attractive for battery operated power systems. The BCT2040 series also offer ultra-low dropout voltage to prolong battery life in portable electronics. Output current minimum limit is 1A, and over-current protection limit is set at 2A typical.

These devices feature a shutdown function and are offered in active low with auto discharge. The output voltage is preset to voltages in the range of 1.0V to 5.0V. Other features include a low shutdown current, fold-back current limit and thermal shutdown protection.

The BCT2040 is available in Green ESOP-8 packages. It operates over an ambient temperature range of -40°C to +85°C.

FEATURES

- Wide Input Voltage Range: 2.2V to 6.0V
- Fixed Outputs of 1.0V, 1.2V, 1.5V, 1.8V, 2.5V, 2.8V, 3.0V 3.3V and 5.0V
- Adjustable Output from 0.8V to 5.0V
- 1A Current Rating
- Low Dropout Voltage
- Output Current Limit
- Quick output discharge
- Thermal-Overload Protection
- High PSRR(65dB at 1kHz)
- -40°C to 85°C Operating Temperature Range
- Available in Green ESOP-8 Packages

APPLICATIONS

Cellular Telephones
Cordless Telephones
PCMCIA Cards
Modems
MP3 Player
Hand-Held Instruments
Portable/Battery-Powered Equipment



BCT2040 1A, Low Dropout, Linear Regulators

ORDERING INFORMATION

Order Number	V _{OUT} (V)	Package Type	Temperature Range	Marking	QTY/Reel
BCT2040EDAV10-TR	1.0	ESOP-8	-40°C to +85°C	2040 10XXX	3000
BCT2040EDAV12-TR	1.2	ESOP-8	-40°C to +85°C	2040 12XXX	3000
BCT2040EDAV15-TR	1.5	ESOP-8	-40°C to +85°C	2040 15XXX	3000
BCT2040EDAV18-TR	1.8	ESOP-8	-40°C to +85°C	2040 18XXX	3000
BCT2040EDAV25-TR	2.5	ESOP-8	-40°C to +85°C	2040 25XXX	3000
BCT2040EDAV28-TR	2.8	ESOP-8	-40°C to +85°C	2040 28XXX	3000
BCT2040EDAV30-TR	3.0	ESOP-8	-40°C to +85°C	2040 30XXX	3000
BCT2040EDAV33-TR	3.3	ESOP-8	-40°C to +85°C	2040 33XXX	3000
BCT2040EDAV50-TR	5.0	ESOP-8	-40°C to +85°C	2040 50XXX	3000
BCT2040EDAVAJ-TR	ADJ	ESOP-8	-40°C to +85°C	2040 AJXXX	3000

ORDER NUMBER

BCT2040 X XX VXX -TR

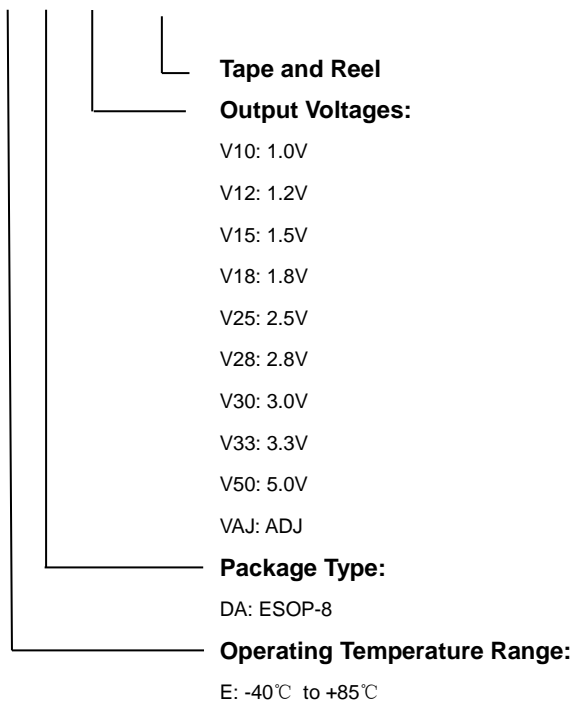

MARKING DESCRIPTION

2040: Part No.

VV: Output Voltage Code

Code	V _{OUT} (V)
10	1.0
12	1.2
15	1.5
18	1.8
25	2.5
28	2.8
30	3.0
33	3.3
50	5.0
AJ	ADJ



XXX: Batch code

PIN CONFIGURATION

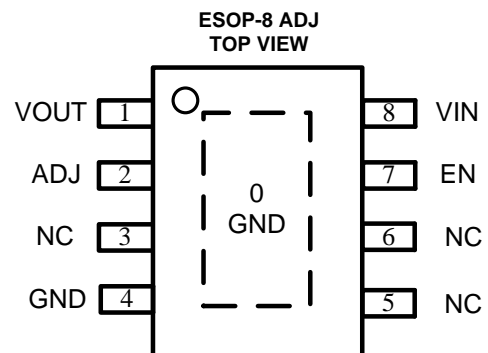
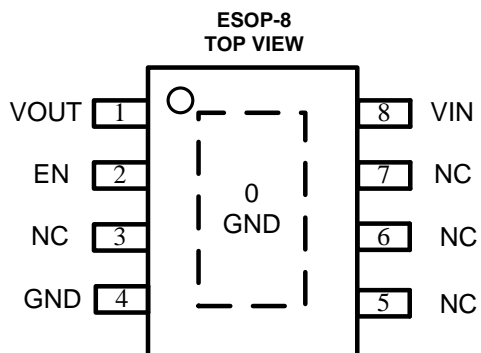

PIN DESCRIPTION

PIN		NAME	FUNCTION
Vxx	ADJ		
1	1	VOUT	Regulator Output.
2		EN	Enable pin, active high.
	2	ADJ	Output voltage adjust pin.
3	3	NC	Not connected.
4	4	GND	Ground
5	5	NC	Not connected.
6	6	NC	Not connected.
7		NC	Not connected.
	7	EN	Enable pin, active high.
8	8	VIN	Regulator Input.
0	0	GND	Ground, Thermal pin.

ABSOLUTE MAXIMUM RATINGS

IN to GND.....	-0.3V to 6.5V
EN to GND.....	-0.3V to V_{IN}
OUT to GND.....	-0.3V to ($V_{IN}+0.3V$)
Output Short-Circuit Duration.....	Infinite
Power Dissipation, $P_D@T_A=25^\circ C$ ESOP-8.....	1.25W
Package Thermal Resistance ESOP-8, θ_{JA}	100°C/W
Junction Temperature.....	150°C
Operating Temperature Range.....	-40°C to +85°C
Storage Temperature Range.....	-65°C to 150°C
Lead Temperature (Soldering, 10 sec).....	260°C
ESD Susceptibility HBM.....	4000V

NOTE:

Stresses beyond those listed under "Absolute Maximum Ratings" may cause permanent damage to the device. These are stress ratings only, and functional operation of the device at these or any other conditions beyond those indicated in the operational sections of the specifications is not implied. Exposure to absolute maximum rating conditions for extended periods may affect device reliability.

CAUTION

This integrated circuit can be damaged by ESD if you don't pay attention to ESD protection. Broadchip recommends that all integrated circuits be handled with appropriate precautions. Failure to observe proper handling and installation procedures can cause damage. ESD damage can range from subtle performance degradation to complete device failure. Precision integrated circuits may be more susceptible to damage because very small parametric changes could cause the device not to meet its published specifications.

Broadchip reserves the right to make any change in circuit design, specification or other related things if necessary without notice at any time. Please contact Broadchip sales office to get the latest datasheet.

ELECTRICAL CHARACTERISTICS

($V_{IN} = V_{OUT(NOMINAL)} + 0.5V^{(1)}$, $T_A = -40^{\circ}C$ to $+85^{\circ}C$, unless otherwise specified.)

PARAMETER	SYM	CONDITIONS	MIN	TYP	MAX	UNITS
Input Voltage	V_{IN}		2.2		6.0	V
Output Voltage Accuracy ⁽¹⁾		$I_{OUT} = 1mA$	-2.0		2.0	%
FB Reference Voltage, ADJ pin	V_{REF}	$I_{OUT} = 1mA$	0.78	0.8	0.82	V
Maximum Output Current ⁽¹⁾		$V_{IN} = 2.2V$ or $(V_{OUT} + 0.5V)$	1			A
Current Limit ⁽¹⁾	I_{LIM}	$V_{IN} = 2.2V$ or $(V_{OUT} + 0.5V)$		1.8		A
Short-Circuit Current ⁽¹⁾	I_{SHORT}	$V_{IN} = 2.2V$ or $(V_{OUT} + 0.5V)$		0.6		A
Ground Pin Current	I_Q	No load, $EN = 2V$		30		μA
Dropout Voltage ⁽²⁾		$V_{OUT} > 2.2V$, $I_{OUT} = 300mA$		0.1	0.2	V
		$V_{OUT} > 2.2V$, $I_{OUT} = 1A$		0.3	0.5	
Line Regulation ⁽¹⁾	ΔV_{LNR}	$V_{IN} = 2.2V$ or $(V_{OUT} + 0.5V)$ to 6V, $I_{OUT} = 1mA$		0.05		%/V
Load Regulation	ΔV_{LDR}	$I_{OUT} = 1mA$ to 1A, $C_{OUT} = 4.7\mu F$, $V_{OUT} > 2V$		0.002		%mA
		$I_{OUT} = 1mA$ to 1A, $C_{OUT} = 4.7\mu F$, $V_{OUT} \leq 2V$		0.004		
Power Supply Rejection Ratio	PSRR	$C_{BP} = 0.1\mu F$, $I_{LOAD} = 50mA$, $C_{OUT} = 4.7\mu F$, $V_{IN} = V_{OUT} + 1V$	$f = 217Hz$		65	dB
			$f = 1kHz$		60	
SHUTDOWN⁽³⁾						
EN Input Threshold	V_{IH}	$V_{IN} = 2.2V$ to 6.0V, $V_{EN} = -0.3V$ to V_{IN}	1.5			V
	V_{IL}				0.3	
EN Input Bias Current	I_{IN}	$EN = 6.0V$		1.5		μA
		$EN = 0V$		0.01		μA
Shutdown Supply Current	$I_{Q(SHDN)}$	$EN = 0.4V$		0.01	1	μA
Shutdown Exit Delay ⁽⁴⁾		$C_{OUT} = 4.7\mu F$, No Load		30		us
THERMAL PROTECTION						
Thermal Shutdown Temperature	T_{SHDN}			150		$^{\circ}C$
Thermal Shutdown Hysteresis	ΔT_{SHDN}			15		$^{\circ}C$

NOTES:

- $V_{IN} = V_{OUT(NOMINAL)} + 0.5V$ or 2.5V, whichever is greater.
- The dropout voltage is defined as $V_{IN} - V_{OUT}$, when V_{OUT} is 100mV below the value of nominal V_{OUT} . (Only applicable for $V_{OUT} > +2.2V$.)
- $V_{EN} = -0.3V$ to V_{IN}
- Time needed for V_{OUT} to reach 90% of final value.

TYPICAL APPLICATION CIRCUIT

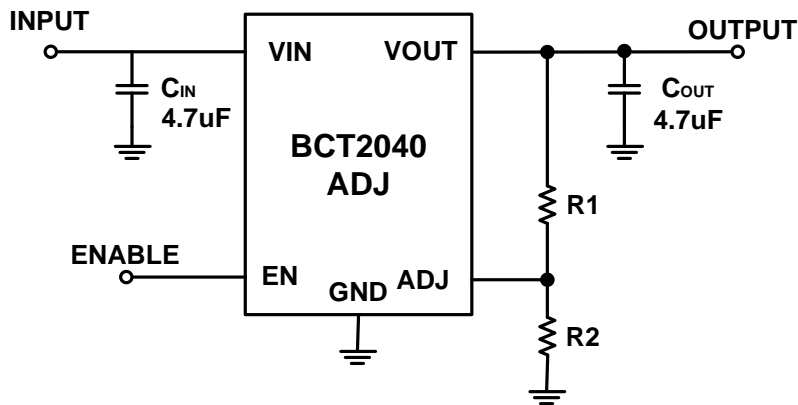
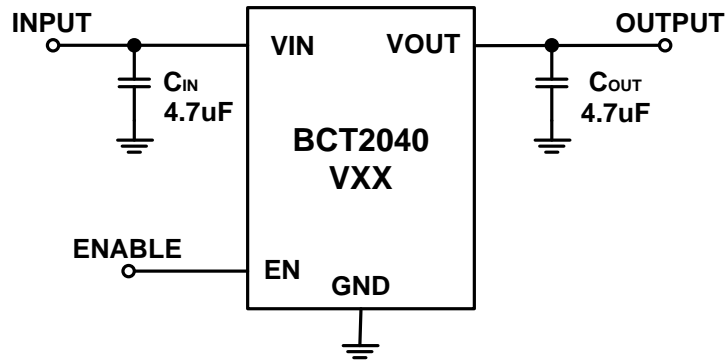

NOTE: $V_{OUT} = (R1 + R2) / R2 \times 0.8 V$

APPLICATION NOTE

Programming the BCT2040 Adjustable LDO regulator

The output voltage of the BCT2040 adjustable regulator is programmed using an external resistor divider as show in Figure as below. The output voltage is calculated using equation as below:

$$V_{OUT} = V_{REF} \times \left(1 + \frac{R1}{R2} \right)$$

Where:

$V_{REF}=0.8V$ typ (the internal reference voltage)

Resistors R1 and R2 should be chosen for approximately 50uA divider current. Lower value resistors can be used for improved noise performance, but the solution consumes more power. Higher resistor values should be avoided as leakage current into/out of FB across R1/R2 creates an offset voltage that artificially increases/decreases the feedback voltage and thus erroneously decrease/increases V_{OUT} .

Enable Function

The BCT2040 features an LDO regulator enable/disable function. To assure the LDO regulator will switch on; the EN turn on control level must be greater than 1.5 volts. The LDO regulator will go into the shutdown mode when the voltage on the EN pin falls below 0.3 volts. For to protect the system, the BCT2040 have a quick discharge function. If the enable function is not needed in a specific application, it may be tied to VIN to keep the LDO regulator in a continuously on state.

Thermal Considerations

Thermal protection limits power dissipation in BCT2040. When the operation junction temperature exceeds 150°C, the OTP circuit starts the thermal shutdown function turn the pass element off. The pass element turns on again after the junction temperature cools by 15°C.

For continue operation, do not exceed absolute maximum operation junction temperature 150°C. The power dissipation definition in device is:

$$P_D = (V_{IN} - V_{OUT}) \times I_{OUT} + V_{IN} \times I_Q$$

The maximum power dissipation depends on the thermal resistance of IC package, PCB layout, the rate of surroundings airflow and temperature difference between junction to ambient. The maximum power dissipation can be calculated by following formula:

$$P_D(\text{MAX}) = (T_J(\text{MAX}) - T_A) / \theta_{JA}$$



BCT2040 1A, Low Dropout, Linear Regulators

Where $T_J(\text{MAX})$ is the maximum operation junction temperature 150°C , T_A is the ambient temperature and the θ_{JA} is the junction to ambient thermal resistance. For recommended operating conditions specification of BCT2040, where $T_J(\text{MAX})$ is the maximum junction temperature of the die (150°C) and T_A is the maximum ambient temperature. The junction to ambient thermal resistance (θ_{JA} is layout dependent) for ESOP-8 package is $100^\circ\text{C}/\text{W}$, on standard JEDEC 51-3 thermal test board. The maximum power dissipation at $T_A = 25^\circ\text{C}$ can be calculated by following formula:

$$P_D(\text{MAX}) = (150^\circ\text{C} - 25^\circ\text{C}) / 100 = 1.25\text{W (ESOP-8)}$$

The maximum power dissipation depends on operating ambient temperature for fixed $T_J(\text{MAX})$ and thermal resistance θ_{JA} . It is also useful to calculate the junction of temperature of the BCT2040 under a set of specific conditions. In this example let the Input voltage $V_{IN} = 3.3\text{V}$, the output current $I_O = 500\text{mA}$ and the case temperature $T_A = 40^\circ\text{C}$ measured by a thermal couple during operation. The power dissipation for the $V_O = 2.8\text{V}$ version of the BCT2040 can be calculated as:

$$\begin{aligned} P_D &= (3.3\text{V} - 2.8\text{V}) \times 500\text{mA} + 3.3\text{V} \times 100\mu\text{A} \\ &= 250.33\text{mW} \end{aligned}$$

And the junction temperature, T_J , can be calculated as follows:

$$\begin{aligned} T_J &= T_A + P_D \times \theta_{JA} = 40^\circ\text{C} + 0.25\text{W} \times 100^\circ\text{C}/\text{W} \\ &= 40^\circ\text{C} + 25^\circ\text{C} = 65^\circ\text{C} < T_J(\text{MAX}) = 150^\circ\text{C} \end{aligned}$$

For this operating condition, T_J is lower than the absolute maximum operating junction temperature, 150°C , so it is safe to use the BCT2040 in this configuration.

PACKAGE OUTLINE DIMENSIONS

ESOP-8

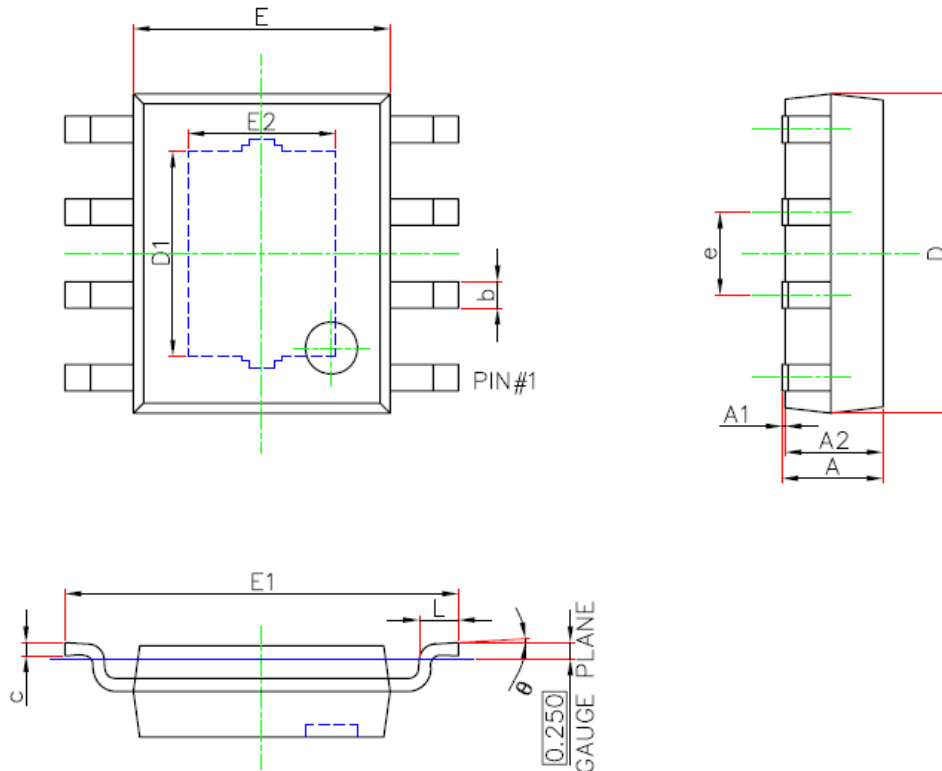

Symbol	Dimensions In Millimeters		Dimensions In Inches	
	Min.	Max.	Min.	Max.
A	1.300	1.700	0.051	0.067
A1	0.000	0.100	0.000	0.004
A2	1.350	1.550	0.053	0.061
b	0.330	0.510	0.013	0.020
c	0.170	0.250	0.007	0.010
D	4.700	5.100	0.185	0.201
D1	3.050	3.250	0.120	0.128
E	3.800	4.000	0.150	0.157
E1	5.800	6.200	0.228	0.244
E2	2.160	2.360	0.085	0.093
e	1.270(BSC)		0.050(BSC)	
L	0.400	1.270	0.016	0.050
θ	0°	8°	0°	8°

PCB Layout Pattern (Unit: mm)

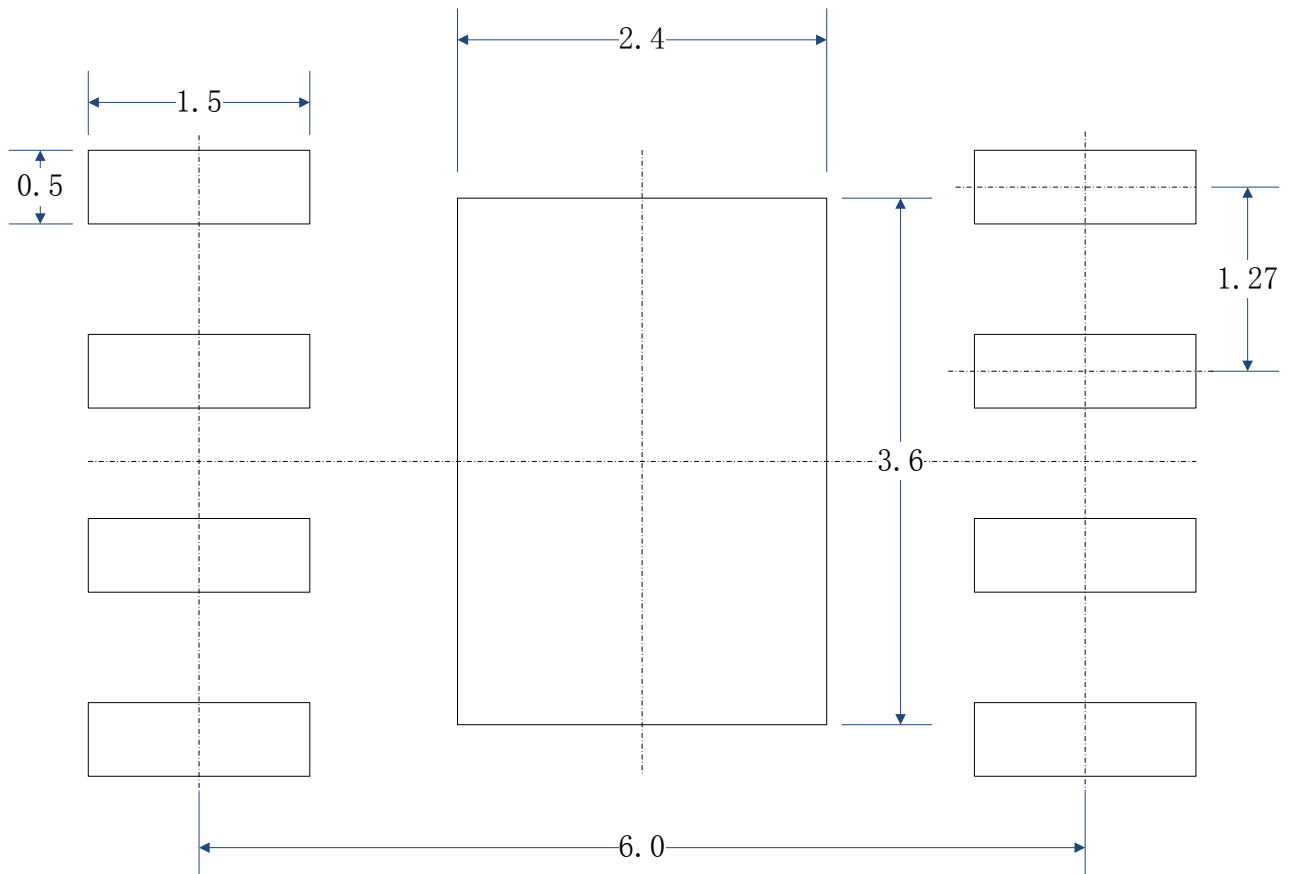

X-ON Electronics

Largest Supplier of Electrical and Electronic Components

Click to view similar products for [Linear Voltage Regulators](#) category:

Click to view products by [BROADCHIP](#) manufacturer:

Other Similar products are found below :

[LV56831P-E](#) [LV5684PVD-XH](#) [MCDTSA6-2R](#) [L7815ACV-DG](#) [PQ3DZ53U](#) [LV56801P-E](#) [TLE42794G](#) [L78L05CZ/1SX](#) [L78LR05DL-MA-E](#) [636416C](#) [714954EB](#) [BA033LBSG2-TR](#) [LV5680P-E](#) [L78M15CV-DG](#) [TLS202B1MBV33HTSA1](#) [L79M05T-E](#) [TLS202A1MBVHTSA1](#) [L78LR05D-MA-E](#) [NCV317MBTG](#) [NTE7227](#) [LV5680NPVC-XH](#) [LT1054CN8](#) [MP2018GZD-5-Z](#) [MP2018GZD-33-Z](#) [MIC5281-3.3YMM](#) [MC78L06BP-AP](#) [TA48LS05F\(TE85L,F\)](#) [TA78L12F\(TE12L,F\)](#) [TC47BR5003ECT](#) [TCR2LN12,LF\(S](#) [TCR2LN28,LF\(S](#) [TCR2LN30,LF\(S](#) [TCR3DF295,LM\(CT](#) [TCR3DF40,LM\(CT](#) [BA178M20CP-E2](#) [L78M12ABDT](#) [LM7812SX/NOPB](#) [LR645N3-G-P003](#) [LR645N3-G-P013](#) [ZXTR2005P5-13](#) [SCD7812BTG](#) [TCR3DF335,LM\(CT](#) [ZXTR2012K-13](#) [TLE42994E V33](#) [ZXTR2008K-13](#) [ZXTR2005K-13](#) [L88R05DL-E](#) [ADP3300ARTZ-2.7RL7](#) [LM120K-15/883](#) [IFX54441LDVXUMA1](#)