



BCT2050

Low Power Low Dropout Regulators

BCT2050

Low Power, Low Dropout Regulators

GENERAL DESCRIPTION

The BCT2050 series are low-power, low-noise, low-dropout CMOS linear voltage regulators. They are the perfect choice for low voltage, low power applications. A low ground current makes this part attractive for battery operated power systems. The BCT2050 series also offer ultra-low dropout voltage to prolong battery life in portable electronics. Systems requiring a quiet voltage sources, such as RF applications, will benefit from the BCT2050 series ultra-low output noise ($30\mu\text{V}_{\text{RMS}}$) and high PSRR. An external noise bypass capacitor connected to the device's BP pin can further reduce the noise level.

Other features include a 10nA logic-controlled shutdown mode, foldback current limit and thermal shutdown protection.

The BCT2050 is available in Green SOT23-5 packages. It operates over an ambient temperature range of -40°C to $+85^{\circ}\text{C}$.

FEATURES

- Low Output Noise
- Low Dropout Voltage
- Thermal-Overload Protection
- Output Current Limit
- High PSRR(74dB at 1kHz)
- 10nA Logic-Controlled Shutdown
- Available in Multiple output Voltage Versions
- Adjustable Output from 0.8V to 5.0V
- -40°C to 85°C Operating Temperature Range
- Available in Green SOT23-5 Packages

APPLICATIONS

Cellular Telephones
Cordless Telephones
PCMCIA Cards
Modems
MP3 Player
Hand-Held Instruments
Portable/Battery-Powered Equipment

ORDERING INFORMATION

Order Number	V _{OUT} (V)	Package Type	Temperature Range	Marking	QTY/Reel
BCT2050EUKAJ-TR	ADJ	SOT23-5	-40°C to $+85^{\circ}\text{C}$	JJXX	3000

"XX" in Marking will be appeared as the batch code.



BCT2050

Low Power

Low Dropout Regulators

ABSOLUTE MAXIMUM RATINGS

IN to GND.....	-0.3V to 6V
EN to GND.....	-0.3V to V_{IN}
OUT, BP/FB to GND.....	-0.3V to ($V_{IN}+0.3V$)
Output Short-Circuit Duration.....	Infinite
Power Dissipation, $P_D@T_A=25^\circ C$	
SOT23-5.....	0.5W
Package Thermal Resistance	
SOT23-5, θ_{JA}	260°C/W
Junction Temperature.....	150°C
Operating Temperature Range.....	-40°C to +85°C
Storage Temperature Range.....	-65°C to 150°C
Lead Temperature (Soldering, 10 sec).....	260°C
ESD Susceptibility	
HBM.....	4000V
MM.....	200V

NOTE:

Stresses beyond those listed under "Absolute Maximum Ratings" may cause permanent damage to the device. These are stress ratings only, and functional operation of the device at these or any other conditions beyond those indicated in the operational sections of the specifications is not implied. Exposure to absolute maximum rating conditions for extended periods may affect device reliability.

CAUTION

This integrated circuit can be damaged by ESD if you don't pay attention to ESD protection. Broadchip recommends that all integrated circuits be handled with appropriate precautions. Failure to observe proper handling and installation procedures can cause damage. ESD damage can range from subtle performance degradation to complete device failure. Precision integrated circuits may be more susceptible to damage because very small parametric changes could cause the device not to meet its published specifications.

Broadchip reserves the right to make any change in circuit design, specification or other related things if necessary without notice at any time. Please contact Broadchip sales office to get the latest datasheet.

PIN CONFIGURATION

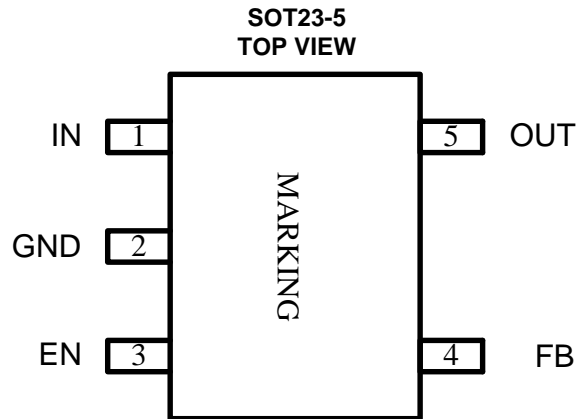

PIN DESCRIPTION

PIN SOT23-5	NAME	FUNCTION
1	IN	Regulator Input. Supply voltage can range from 1.6V to 5.5V. Bypass with a 1uF capacitor to GND.
2	GND	Ground.
3	EN	Shutdown Input. A logic low reduces the supply current to 10nA. Connect to IN for normal operation.
4	FB	This is used to set the output voltage of the device.
5	OUT	Regulator Output.

ELECTRICAL CHARACTERISTICS

($V_{IN} = V_{OUT(NOMINAL)} + 0.5V^{(1)}$, Full = $-40^{\circ}C$ to $+85^{\circ}C$, unless otherwise specified.)

PARAMETER	SYM	CONDITIONS	MIN	TYP	MAX	UNITS	
Input Voltage	V_{IN}		1.6		5.5	V	
Output Voltage Accuracy ⁽¹⁾		$I_{OUT} = 0.1mA$	-2.0%		2.0%	V	
FB Voltage Accuracy ⁽¹⁾		$I_{OUT} = 0.1mA$	0.784	0.8	0.816	V	
Maximum Output Current				500		mA	
Current Limit	I_{LIM}			800		mA	
Ground Pin Current	I_Q	No load, $EN = V_{IN}$		30		uA	
		$I_{OUT} = 500mA$		626		mV	
			$V_{OUT} = 0.8V$		345		
			$V_{OUT} = 1.2V$		116		
			$V_{OUT} = 2.8V$		105		
			$V_{OUT} = 3.3V$		88		
		$V_{OUT} = 5.0V$					
Line Regulation	ΔV_{LNR}	$V_{IN} = 1.6V$ or $(V_{OUT} + 0.5V)$ to $5.5V$, $I_{OUT} = 1mA$		0.02	0.05	%/V	
Load Regulation	ΔV_{LDR}	$I_{OUT} = 1mA$ to $500mA$, $C_{OUT} = 1\mu F$, $V_{OUT} > 2V$		0.002	0.005	%mA	
		$I_{OUT} = 1mA$ to $500mA$, $C_{OUT} = 1\mu F$, $V_{OUT} \leq 2V$		0.004	0.008		
Output Voltage Noise	e_n	$f = 10Hz$ to $100kHz$, $C_{OUT} = 10\mu F$		150		μV_{RMS}	
Power Supply Rejection Ratio	PSRR	$I_{LOAD} = 50mA$, $C_{OUT} = 1\mu F$, $V_{IN} = V_{OUT} + 1V$ $f = 1kHz$		74		dB	

SHUTDWON⁽³⁾

EN Input Threshold	V_{IH}	$V_{IN} = 1.6V$ to $5.5V$,	1.5	1.6	V_{IN}	V
	V_{IL}	$V_{EN} = -0.3V$ to V_{IN}	0	0.15	0.3	
EN Input Bias Current	I_{IN}	$EN = 5.5V$		1		uA
		$EN = 0V$		0.01		uA
Shutdown Supply Current	$I_{Q(SHDN)}$	$EN = 0V$		0.01		uA
Shutdown Exit Delay ⁽⁴⁾		$C_{OUT} = 1\mu F$, No Load		20		us

THERMAL PROTECTION

Thermal Shutdown Temperature	T_{SHDN}			150		$^{\circ}C$
Thermal Shutdown Hysteresis	ΔT_{SHDN}			15		$^{\circ}C$

NOTES:

1. $V_{IN} = V_{OUT(NOMINAL)} + 0.5V$ or $1.6V$, whichever is greater.

2. The dropout voltage is defined as $V_{IN} - V_{OUT}$, when V_{OUT} is 100mV below the value of V_{OUT} .

Guaranteed by characterization., when V_{OUT} is below the of 1.6V

3. $V_{EN} = -0.3V$ to V_{IN}

4. Time needed for V_{OUT} to reach 90% of final value.

TYPICAL APPLICATION CIRCUIT

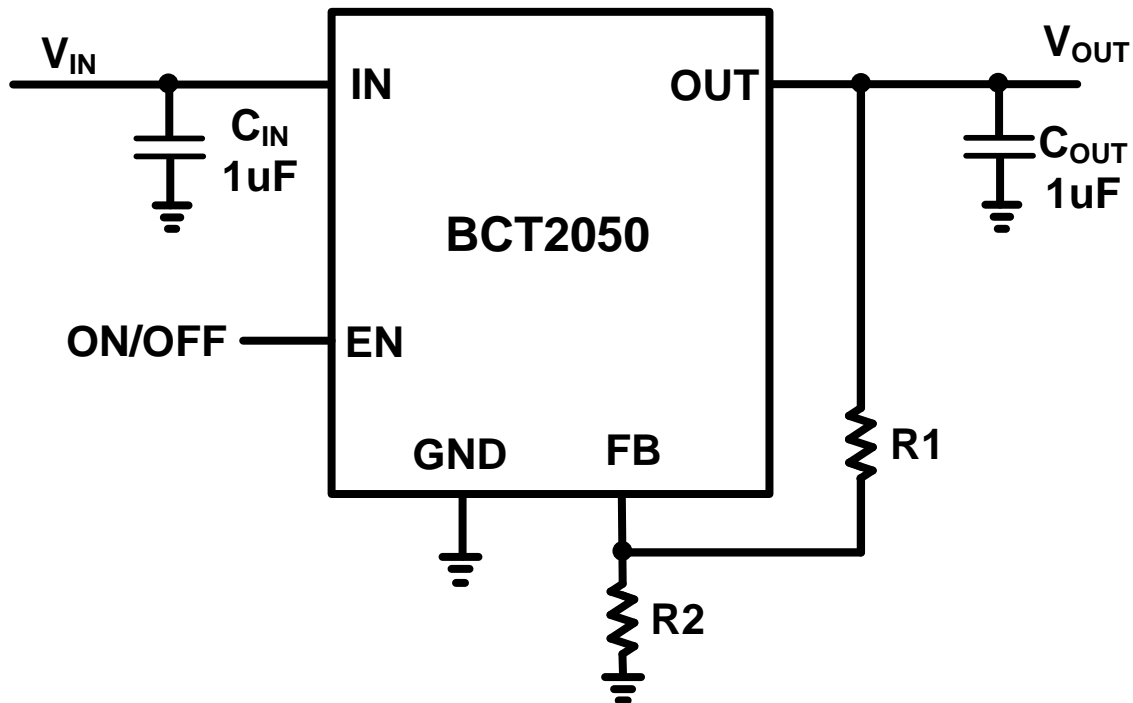

Enable Function

The BCT2050 features an LDO regulator en-able/disable function. To assure the LDO regulator will switch on; the EN turn on control level must be greater than 1.5 volts. The LDO regulator will go into the shutdown mode when the voltage on the EN pin falls below 0.3 volts. For to protect the system, the BCT2050 have a quick discharge function. If the enable function is not needed in a specific application, it may be tied to VIN to keep the LDO regulator in a continuously on state.

Programming the BCT2050 Adjustable LDO regulator

The output voltage of the BCT2050 adjustable regulator is programmed using an external resistor divider as show in Figure as below. The output voltage is calculated using equation as below:

$$V_{OUT} = V_{REF} \times \left(1 + \frac{R1}{R2} \right)$$

Where:

$V_{REF}=0.8V$ typ (the internal reference voltage)

Resistors R1 and R2 should be chosen for approximately 50uA divider current. Lower value resistors can be used for improved noise performance, but the solution consumes more power. Higher resistor values should be avoided as leakage current into/out of FB across R1/R2 creates an offset voltage that artificially increases/decreases the feedback voltage and thus erroneously decrease/increases V_{OUT} .

Thermal Considerations

Thermal protection limits power dissipation in BCT2050. When the operation junction temperature exceeds 150°C, the OTP circuit starts the thermal shutdown function turn the pass element off. The pass element turns on again after the junction temperature cools by 15°C.

For continue operation, do not exceed absolute maximum operation junction temperature 150°C. The power dissipation definition in device is:

$$P_D = (V_{IN} - V_{OUT}) \times I_{OUT} + V_{IN} \times I_Q$$

The maximum power dissipation depends on the thermal resistance of IC package, PCB layout, the rate of surroundings airflow and temperature difference between junction to ambient. The maximum power dissipation can be calculated by following formula:

$$P_D(\text{MAX}) = (T_J(\text{MAX}) - T_A) / \theta_{JA}$$

Where $T_J(\text{MAX})$ is the maximum operation junction temperature 150°C, T_A is the ambient temperature and the θ_{JA} is the junction to ambient thermal resistance. For recommended operating conditions specification of BCT2050, where $T_J(\text{MAX})$ is the maximum junction temperature of the die (150°C) and T_A is the maximum ambient temperature. The junction to ambient thermal resistance (θ_{JA} is layout

dependent) for SOT23-5 package is 260°C/W, on standard JEDEC 51-3 thermal test board. The maximum power dissipation at $T_A = 25^\circ\text{C}$ can be calculated by following formula:

$$P_D(\text{MAX}) = (150^\circ\text{C} - 25^\circ\text{C}) / 260 = 481\text{mW (SOT23-5)}$$

The maximum power dissipation depends on operating ambient temperature for fixed $T_J(\text{MAX})$ and thermal resistance θ_{JA} . It is also useful to calculate the junction of temperature of the BCT2050 under a set of specific conditions. In this example let the Input voltage $V_{IN} = 3.3\text{V}$, the output current $I_O = 300\text{mA}$ and the case temperature $T_A = 40^\circ\text{C}$ measured by a thermal couple during operation. The power dissipation for the $V_O = 2.8\text{V}$ of the BCT2050 can be calculated as:

$$P_D = (3.3\text{V} - 2.8\text{V}) \times 300\text{mA} + 3.6\text{V} \times 30\mu\text{A} \\ = 150.108\text{mW}$$

And the junction temperature, T_J , can be calculated as follows:

$$T_J = T_A + P_D \times \theta_{JA} = 40^\circ\text{C} + 0.15\text{W} \times 260^\circ\text{C/W} \\ = 40^\circ\text{C} + 39^\circ\text{C} = 79^\circ\text{C} < T_J(\text{MAX}) = 150^\circ\text{C}$$

For this operating condition, T_J is lower than the absolute maximum operating junction temperature, 150°C , so it is safe to use the BCT2050 in this configuration.

Package Outline Dimensions

SOT23-5

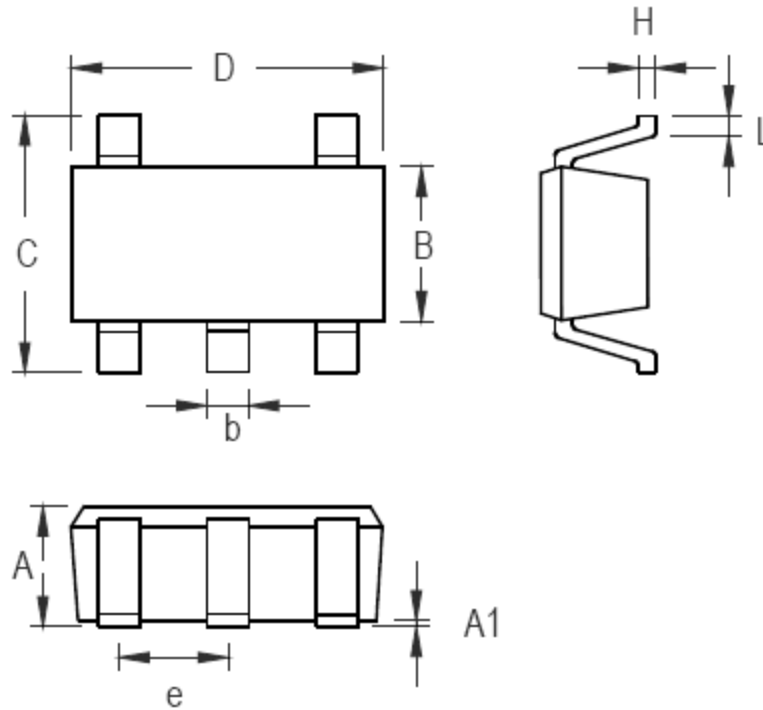

Symbol	Dimensions In Millimeters	
	Min	Max
A	1.05	1.15
A1	0.03	0.15
B	1.5	1.7
b	0.28	0.45
C	2.75	3.05
D	2.82	3.02
e	0.95(BSC)	
H	0.12	0.23
L	0.35	0.55

SOT23-5 Surface Mount Package

PCB Layout Pattern: SOT23-5 (Unit: mm)

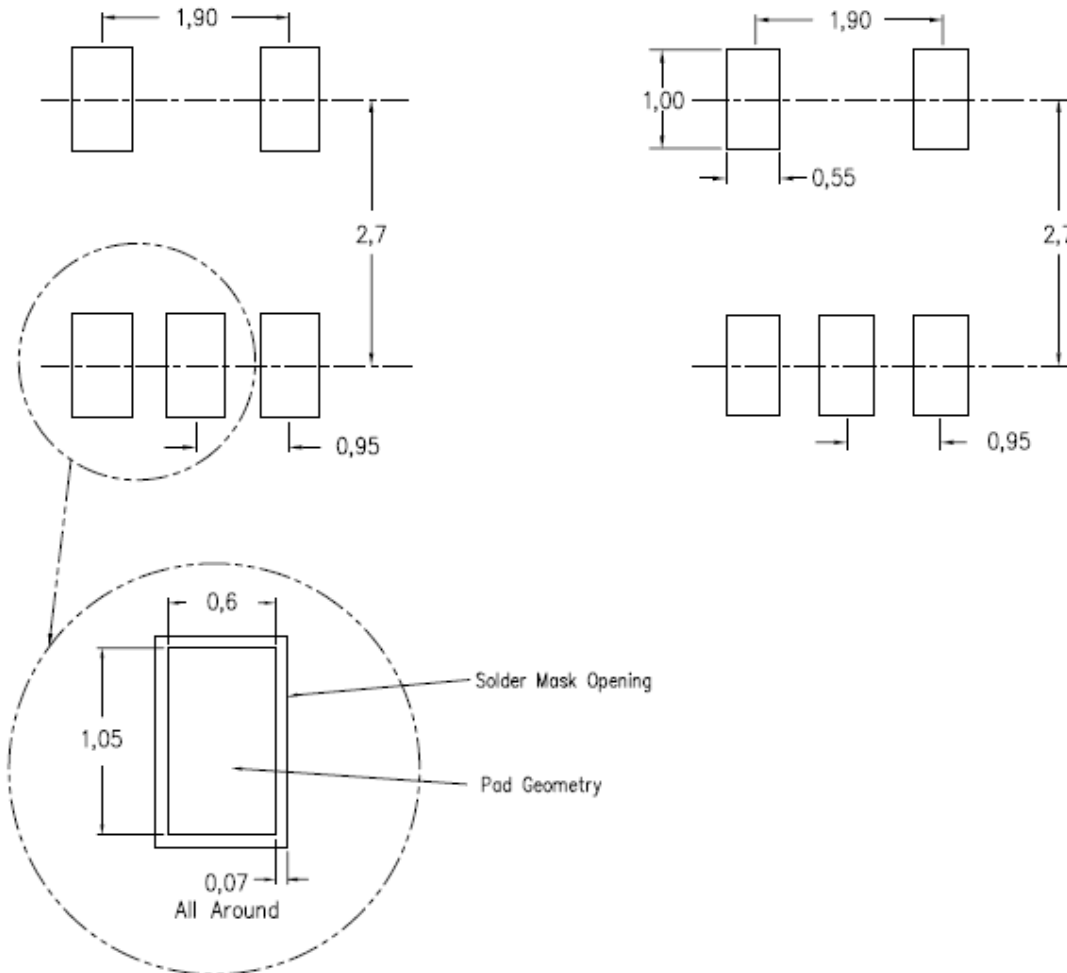

X-ON Electronics

Largest Supplier of Electrical and Electronic Components

Click to view similar products for [Linear Voltage Regulators](#) category:

Click to view products by [BROADCHIP](#) manufacturer:

Other Similar products are found below :

[LV56831P-E](#) [LV5684PVD-XH](#) [MCDTSA6-2R](#) [L7815ACV-DG](#) [PQ3DZ53U](#) [LV56801P-E](#) [TLE42794G](#) [L78L05CZ/1SX](#) [L78LR05DL-MA-E](#) [636416C](#) [714954EB](#) [BA033LBSG2-TR](#) [LV5680P-E](#) [L78M15CV-DG](#) [L79M05T-E](#) [TLS202A1MBVHTSA1](#) [L78LR05D-MA-E](#) [NCV317MBTG](#) [NTE7227](#) [LV5680NPVC-XH](#) [LT1054CN8](#) [MP2018GZD-5-Z](#) [MP2018GZD-33-Z](#) [MIC5281-3.3YMM](#) [MC78L06BP-AP](#) [TA48LS05F\(TE85L,F\)](#) [TA78L12F\(TE12L,F\)](#) [TC47BR5003ECT](#) [TCR2LN12,LF\(S](#) [TCR2LN28,LF\(S](#) [TCR2LN30,LF\(S](#) [TCR3DF295,LM\(CT](#) [TCR3DF40,LM\(CT](#) [BA178M20CP-E2](#) [L78M12ABDT](#) [LM7812SX/NOPB](#) [LR645N3-G-P003](#) [LR645N3-G-P013](#) [ZXTR2005P5-13](#) [SCD7812BTG](#) [TCR3DF335,LM\(CT](#) [ZXTR2012K-13](#) [TLE42994E V33](#) [ZXTR2008K-13](#) [ZXTR2005K-13](#) [L88R05DL-E](#) [ADP3300ARTZ-2.7RL7](#) [LM120K-15/883](#) [IFX54441LDVXUMA1](#) [LM317D2T-TR](#)