



---

## BCT2057 1A Low Dropout Linear Regulators

### GENERAL DESCRIPTION

The BCT2057 series low-power, low-noise, low-dropout, CMOS linear voltage regulators operate from a 1.6V to 5.5V input voltage. They are the perfect choice for low voltage, low power applications. A low ground current makes this part attractive for battery operated power systems. The BCT2057 series also offer ultra-low dropout voltage to prolong battery life in portable electronics. Output current minimum limit is 1A, and over-current protection limit is set at 1.8A typical.

These devices feature a shutdown function and are offered in active low with auto discharge. The output voltage is preset to voltages in the range of 0.8V to 5.0V. Other features include a low shutdown current, fold-back current limit and thermal shutdown protection.

The BCT2057 is available in Green SOT23-5 or DFN2x2-6L Packages. It operates over an ambient temperature range of -40°C to +85°C.

### FEATURES

- Wide Input Voltage Range: 1.6V to 5.5V
- Fixed Outputs of  
0.8V,0.9V,1.0V,1.05V,1.1V,1.2V,1.3V,1.35,1.5V,1.8V,2.2V,2.5V,2.8V,3.0V 3.3V and 3.6V
- 1A Current Rating
- Adjustable Output from 0.8V to 5.0V
- Low Dropout Voltage
- Output Current Limit
- Quick output discharge
- Thermal-Overload Protection
- High PSRR(60dB at 1kHz)
- -40°C to 85°C Operating Temperature Range
- Green SOT23-5 or DFN2x2-6L Packages

### APPLICATIONS

Cellular Telephones  
Cordless Telephones  
PCMCIA Cards  
Modems  
MP3 Player  
Hand-Held Instruments  
Portable/Battery-Powered Equipment



# BCT2057 1A, Low Dropout, Linear Regulators

## ORDERING INFORMATION

Order Number	V <sub>OUT</sub> (V)	Package Type	Temperature Range	Marking	QTY/Reel
BCT2057EUK08-TR	0.8	SOT23-5	-40°C to +85°C	G8XX	3000
BCT2057EUK09-TR	0.9	SOT23-5	-40°C to +85°C	G9XX	3000
BCT2057EUK10-TR	1.0	SOT23-5	-40°C to +85°C	G0XX	3000
BCT2057EUK1A-TR	1.05	SOT23-5	-40°C to +85°C	GAXX	3000
BCT2057EUK11-TR	1.1	SOT23-5	-40°C to +85°C	G1XX	3000
BCT2057EUK12-TR	1.2	SOT23-5	-40°C to +85°C	G2XX	3000
BCT2057EUK13-TR	1.3	SOT23-5	-40°C to +85°C	G3XX	3000
BCT2057EUK1B-TR	1.35	SOT23-5	-40°C to +85°C	GBXX	3000
BCT2057EUK15-TR	1.5	SOT23-5	-40°C to +85°C	G5XX	3000
BCT2057EUK18-TR	1.8	SOT23-5	-40°C to +85°C	G8XX	3000
BCT2057EUK22-TR	2.2	SOT23-5	-40°C to +85°C	G2XX	3000
BCT2057EUK25-TR	2.5	SOT23-5	-40°C to +85°C	G5XX	3000
BCT2057EUK28-TR	2.8	SOT23-5	-40°C to +85°C	G8XX	3000
BCT2057EUK30-TR	3.0	SOT23-5	-40°C to +85°C	G0XX	3000
BCT2057EUK33-TR	3.3	SOT23-5	-40°C to +85°C	G3XX	3000
BCT2057EUK36-TR	3.6	SOT23-5	-40°C to +85°C	G6XX	3000
BCT2057EUKAJ-TR	ADJ	SOT23-5	-40°C to +85°C	GJXX	3000
BCT2057ELT08-TR	0.8	DFN2x2-6L	-40°C to +85°C	G8XX	3000
BCT2057ELT09-TR	0.9	DFN2x2-6L	-40°C to +85°C	G9XX	3000
BCT2057ELT10-TR	1.0	DFN2x2-6L	-40°C to +85°C	G0XX	3000
BCT2057ELT1A-TR	1.05	DFN2x2-6L	-40°C to +85°C	GAXX	3000
BCT2057ELT11-TR	1.1	DFN2x2-6L	-40°C to +85°C	G1XX	3000
BCT2057ELT12-TR	1.2	DFN2x2-6L	-40°C to +85°C	G2XX	3000
BCT2057ELT13-TR	1.3	DFN2x2-6L	-40°C to +85°C	G3XX	3000
BCT2057ELT1B-TR	1.35	DFN2x2-6L	-40°C to +85°C	GBXX	3000
BCT2057ELT15-TR	1.5	DFN2x2-6L	-40°C to +85°C	G5XX	3000
BCT2057ELT18-TR	1.8	DFN2x2-6L	-40°C to +85°C	G8XX	3000
BCT2057ELT22-TR	2.2	DFN2x2-6L	-40°C to +85°C	G2XX	3000
BCT2057ELT25-TR	2.5	DFN2x2-6L	-40°C to +85°C	G5XX	3000
BCT2057ELT28-TR	2.8	DFN2x2-6L	-40°C to +85°C	G8XX	3000
BCT2057ELT30-TR	3.0	DFN2x2-6L	-40°C to +85°C	G0XX	3000
BCT2057ELT33-TR	3.3	DFN2x2-6L	-40°C to +85°C	G3XX	3000
BCT2057ELT36-TR	3.6	DFN2x2-6L	-40°C to +85°C	G6XX	3000
BCT2057ELTAJ-TR	ADJ	DFN2x2-6L	-40°C to +85°C	GJXX	3000



# BCT2057 1A, Low Dropout, Linear Regulators

---

## ORDER NUMBER

BCT2057 X XX XX -TR

Tape and Reel

### Output Voltages:

08:0.8V

09:0.9V

10:1.0V

1A:1.05V

11:1.1V

12:1.2V

13:1.3V

1B:1.35V

15:1.5V

18:1.8V

22:2.2V

25:2.5V

28:2.8V

30:3.0V

33:3.3V

36:3.6V

AJ:ADJ

### Package Type:

UK: SOT23-5

LT: DFN2x2-6L

### Operating Temperature Range:

E: -40°C to +85°C

## MARKING DESCRIPTION

### GVXX

G: Product code.

V: Output Voltage Code. 8:0.8V, 9:0.9V, 0:1.0V, A:1.05V, 1:1.1V, 2:1.2V, 3:1.3V, B:1.35V, 5:1.5V, 8:1.8V, 2:2.2V, 5:2.5V, 8:2.8V, 0:3.0V, 3:3.3V, 6:3.6V, J:ADJ.

XX: Batch code.

## PIN CONFIGURATION

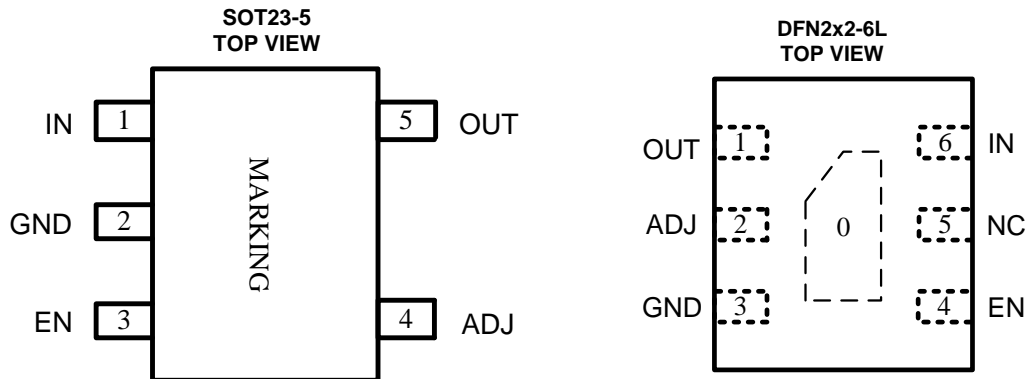

## PIN DESCRIPTION

PIN		NAME	FUNCTION
SOT23-5	DFN2x2-6L		
1	6	IN	Regulator Input.
2	3	GND	Ground
3	4	EN	Enable pin, active high.
4	2	ADJ	Output voltage adjust pin.(NC when fixed output )
5	1	OUT	Regulator Output.
-	0	GND	Ground, Thermal pin.
-	5	NC	No connect.

## TYPICAL APPLICATION CIRCUIT

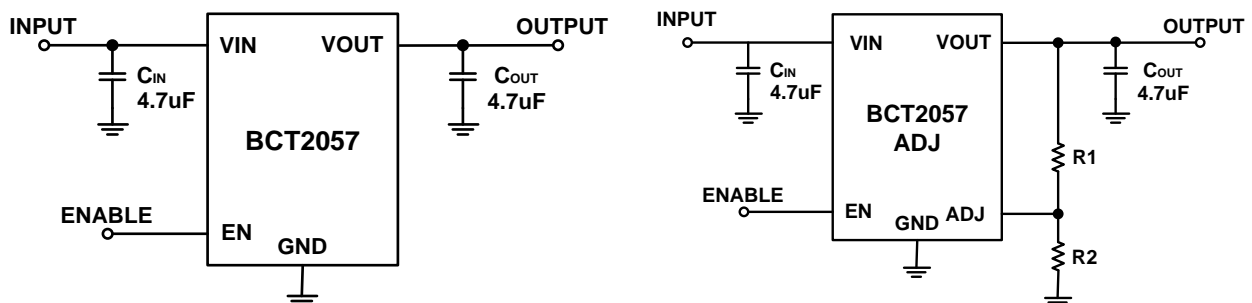



# BCT2057 1A, Low Dropout, Linear Regulators

## ABSOLUTE MAXIMUM RATINGS

IN to GND.....	-0.3V to 6.5V
EN to GND.....	-0.3V to $V_{IN}$
OUT to GND.....	-0.3V to ( $V_{IN}+0.3V$ )
Output Short-Circuit Duration.....	Infinite
Power Dissipation, $P_D@T_A=25^\circ C$	
SOT23-5.....	0.5W
DFN2x2-6L.....	0.9W
Package Thermal Resistance	
SOT23-5, $\theta_{JA}$ .....	260°C/W
DFN2x2-6L, $\theta_{JA}$ .....	140°C/W
Junction Temperature.....	150°C
Operating Temperature Range.....	-40°C to +85°C
Storage Temperature Range.....	-65°C to 150°C
Lead Temperature (Soldering, 10 sec).....	260°C
ESD Susceptibility HBM.....	4000V

### NOTE:

Stresses beyond those listed under “Absolute Maximum Ratings” may cause permanent damage to the device. These are stress ratings only, and functional operation of the device at these or any other conditions beyond those indicated in the operational sections of the specifications is not implied. Exposure to absolute maximum rating conditions for extended periods may affect device reliability.

## CAUTION

This integrated circuit can be damaged by ESD if you don't pay attention to ESD protection. Broadchip recommends that all integrated circuits be handled with appropriate precautions. Failure to observe proper handling and installation procedures can cause damage. ESD damage can range from subtle performance degradation to complete device failure. Precision integrated circuits may be more susceptible to damage because very small parametric changes could cause the device not to meet its published specifications.

Broadchip reserves the right to make any change in circuit design, specification or other related things if necessary without notice at any time. Please contact Broadchip sales office to get the latest datasheet.

### ELECTRICAL CHARACTERISTICS

( $V_{IN} = V_{OUT(NOMINAL)} + 0.5V^{(1)}$ ,  $T_A = -40^{\circ}C$  to  $+85^{\circ}C$ , unless otherwise specified.)

PARAMETER	SYM	CONDITIONS	MIN	TYP	MAX	UNITS
Input Voltage	$V_{IN}$		1.6		5.5	V
Output Voltage Accuracy <sup>(1)</sup>		$I_{OUT} = 1mA$	-2.0		2.0	%
Maximum Output Current <sup>(1)</sup>		$V_{IN} = 1.6V$ or $(V_{OUT} + 0.5V)$	1			A
Current Limit <sup>(1)</sup>	$I_{LIM}$	$V_{IN} = 1.6V$ or $(V_{OUT} + 0.5V)$		1.8		A
Short-Circuit Current <sup>(1)</sup>	$I_{SHORT}$	$V_{IN} = 1.6V$ or $(V_{OUT} + 0.5V)$		0.6		A
Ground Pin Current	$I_Q$	No load, $EN = 2V$		30	100	$\mu A$
Dropout Voltage <sup>(2)</sup>	$I_{OUT} = 600mA$	$V_{OUT} < 1.2V$		0.65		V
		$1.2V \leq V_{OUT} < 2.5V$		0.35		
		$V_{OUT} \geq 2.5V$		0.22		
	$I_{OUT} = 1A$	$V_{OUT} < 1.2V$		1		
		$1.2V \leq V_{OUT} < 2.5V$		0.55		
		$V_{OUT} \geq 2.5V$		0.35		
Line Regulation <sup>(1)</sup>	$\Delta V_{LNR}$	$V_{IN} = 1.6V$ or $(V_{OUT} + 0.5V)$ to $5.5V$ , $I_{OUT} = 1mA$		0.05		%/V
Load Regulation	$\Delta V_{LDR}$	$I_{OUT} = 1mA$ to $1A$ , $C_{OUT} = 4.7\mu F$ , $V_{OUT} > 2V$		0.002		%mA
		$I_{OUT} = 1mA$ to $1A$ , $C_{OUT} = 4.7\mu F$ , $V_{OUT} \leq 2V$		0.004		
Power Supply Rejection Ratio	PSRR	$I_{LOAD} = 50mA$ , $C_{OUT} = 4.7\mu F$ , $V_{IN} = V_{OUT} + 1V$	$f = 217Hz$		65	dB
			$f = 1kHz$		60	
<b>SHUTDWON<sup>(3)</sup></b>						
EN Input Threshold	$V_{IH}$	$V_{IN} = 1.6V$ to $5.5V$ ,	1.5			V
	$V_{IL}$	$V_{EN} = -0.3V$ to $V_{IN}$			0.3	
EN Input Bias Current	$I_{B(SHDN)}$	$EN = 0V$ or $EN = V_{IN}$		0.01	1	$\mu A$
Shutdown Supply Current	$I_{Q(SHDN)}$	$EN = 0.4V$		0.01	1	$\mu A$
Shutdown Exit Delay <sup>(4)</sup>		$C_{OUT} = 4.7\mu F$ , No Load		30		us
<b>THERMAL PROTECTION</b>						
Thermal Shutdown Temperature	$T_{SHDN}$			150		$^{\circ}C$
Thermal Shutdown Hysteresis	$\Delta T_{SHDN}$			15		$^{\circ}C$

**NOTES:**

- $V_{IN} = V_{OUT (NOMINAL)} + 0.5V$  or  $1.6V$ , whichever is greater.
- The dropout voltage is defined as  $V_{IN} - V_{OUT}$ , when  $V_{OUT}$  is 100mV below the value of nominal  $V_{OUT}$ .

3. VEN = -0.3V to VIN

4. Time needed for VOUT to reach 90% of final value.

## APPLICATION NOTE

### Enable Function

The BCT2057 features an LDO regulator enable/disable function. To assure the LDO regulator will switch on; the EN turn on control level must be greater than 1.5 volts. The LDO regulator will go into the shutdown mode when the voltage on the EN pin falls below 0.3 volts. For to protect the system, the BCT2057 have a quick discharge function. If the enable function is not needed in a specific application, it may be tied to VIN to keep the LDO regulator in a continuously on state.

### Thermal Considerations

Thermal protection limits power dissipation in BCT2057. When the operation junction temperature exceeds 150°C, the OTP circuit starts the thermal shutdown function turn the pass element off. The pass element turns on again after the junction temperature cools by 15°C.

For continue operation, do not exceed absolute maximum operation junction temperature 150°C. The power dissipation definition in device is:

$$P_D = (V_{IN} - V_{OUT}) \times I_{OUT} + V_{IN} \times I_Q$$

The maximum power dissipation depends on the thermal resistance of IC package, PCB layout, the rate of surroundings airflow and temperature difference between junction to ambient. The maximum power dissipation can be calculated by following formula:

$$P_D(\text{MAX}) = (T_J(\text{MAX}) - T_A) / \theta_{JA}$$

Where  $T_J(\text{MAX})$  is the maximum operation junction temperature 150°C,  $T_A$  is the ambient temperature and the  $\theta_{JA}$  is the junction to ambient thermal resistance. For recommended operating conditions specification of BCT2032, where  $T_J(\text{MAX})$  is the maximum junction temperature of the die (150°C) and  $T_A$  is the maximum ambient temperature. The junction to ambient thermal resistance ( $\theta_{JA}$  is layout dependent) for SOT23-5 package is 260°C/W, DFN2x2-6L package is 140°C/W, on standard JEDEC 51-3 thermal test board. The maximum power dissipation at  $T_A = 25^\circ\text{C}$  can be calculated by following formula:

$$P_D(\text{MAX}) = (150^\circ\text{C} - 25^\circ\text{C}) / 140 = 893\text{mW (DFN2x2-6L)}$$

$$P_D(\text{MAX}) = (150^\circ\text{C} - 25^\circ\text{C}) / 260 = 481\text{mW (SOT23-5)}$$

---

The maximum power dissipation depends on operating ambient temperature for fixed  $T_J(\text{MAX})$  and thermal resistance  $\theta_{JA}$ . It is also useful to calculate the junction of temperature of the BCT2057 under a set of specific conditions. In this example let the Input voltage  $V_{IN}=3.3V$ , the output current  $I_o=1000mA$  and the case temperature  $T_A=40^\circ C$  measured by a thermal couple during operation. The power dissipation for the  $V_o=2.8V$  version of the BCT2057 can be calculated as:

$$P_D = (3.3V - 2.8V) \times 1000mA + 3.3V \times 100\mu A \\ = 500.33mW$$

And the junction temperature,  $T_J$ , can be calculated as follows:

$$T_J = T_A + P_D \times \theta_{JA} = 40^\circ C + 0.5W \times 140^\circ C/W (\text{DFN}2 \times 2 - 6L) \\ = 40^\circ C + 70^\circ C = 110^\circ C < T_J(\text{MAX}) = 150^\circ C$$

For this operating condition,  $T_J$  is lower than the absolute maximum operating junction temperature,  $150^\circ C$ , so it is safe to use the BCT2057 in this configuration.



## PACKAGE OUTLINE DIMENSIONS

SOT23-5

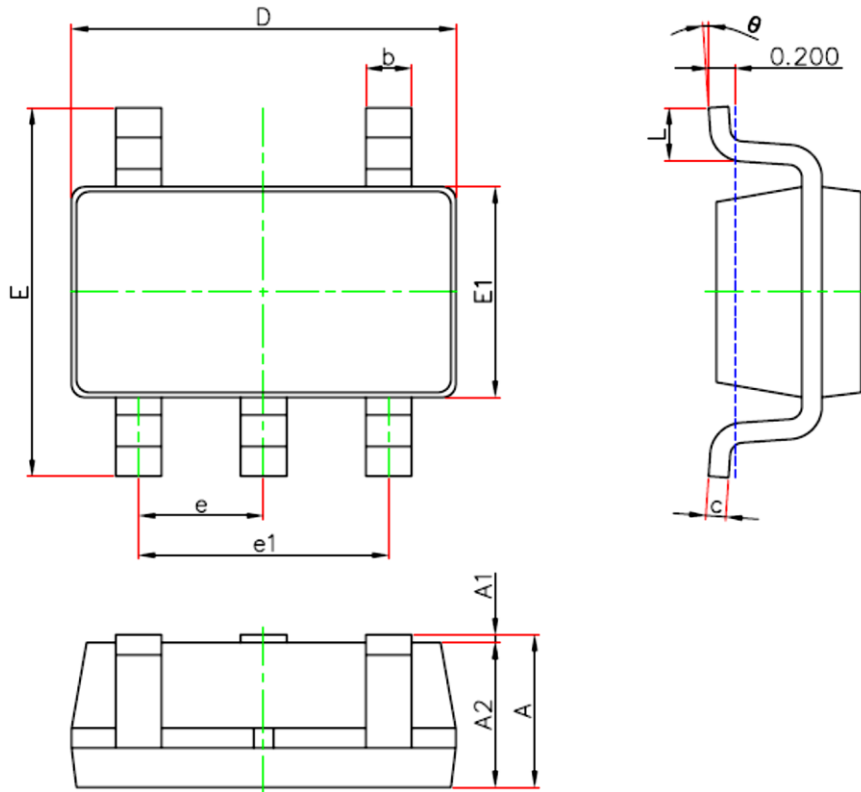

Symbol	Dimensions In Millimeters	
	Min	Max
A	1.05	1.3
A1	0	0.15
A2	1.05	1.15
b	0.28	0.5
c	0.1	0.23
D	2.82	3.02
E1	1.5	1.7
E	2.65	3.05
e	0.95(BSC)	
e1	1.8	2
L	0.3	0.6
θ	0	8°

SOT23-5 Surface Mount Package

## Package Information

DFN2x2-6L

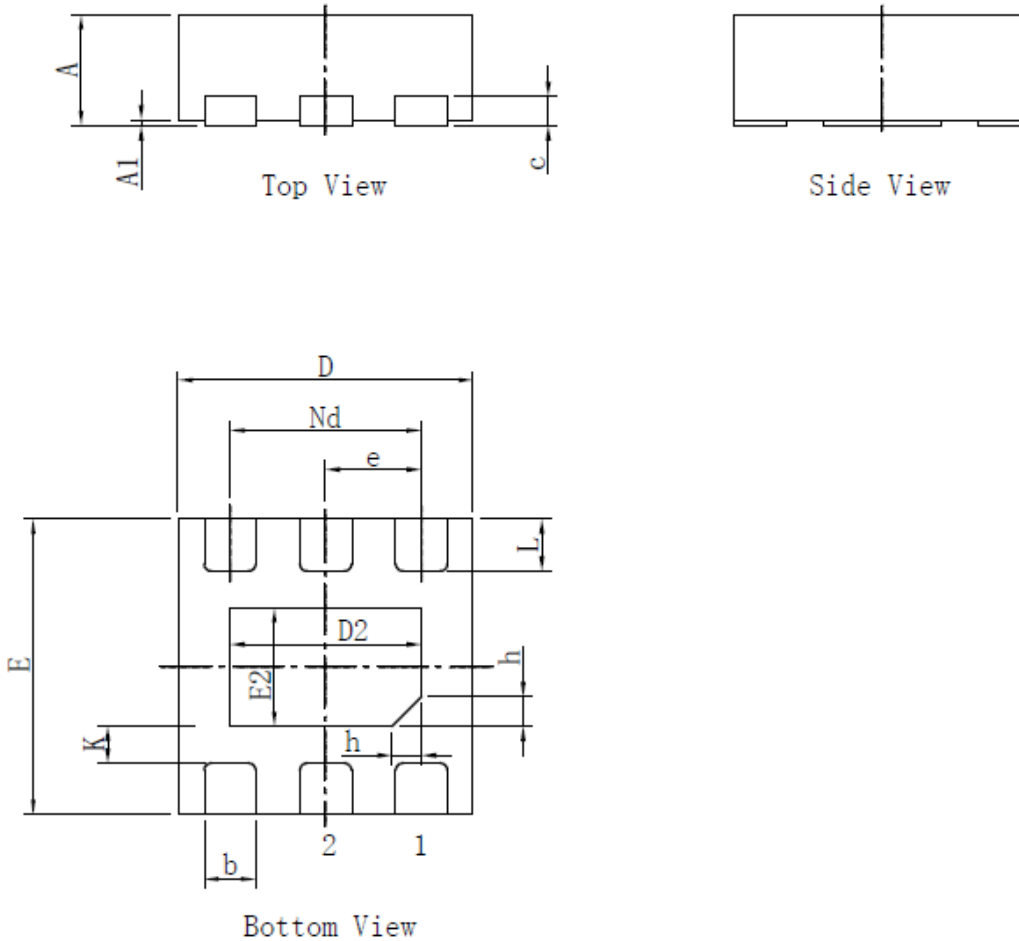

Symbol	Dimensions in Millimeters		
	Min.	Typ.	Max.
A	0.70	0.75	0.80
A1	0.00	0.02	0.05
b	0.30	0.35	0.40
c	0.18	0.20	0.25
D	1.95	2.00	2.05
D2	1.25	1.30	1.35
E	1.95	2.00	2.05
E2	0.75	0.80	0.85
e	0.650BSC		
Nd	1.300BSC		
K	0.20	-	-
L	0.28	0.33	0.38
h	0.15	0.20	0.25

**PCB Layout Pattern (Unit: mm)**

**SOT23-5**

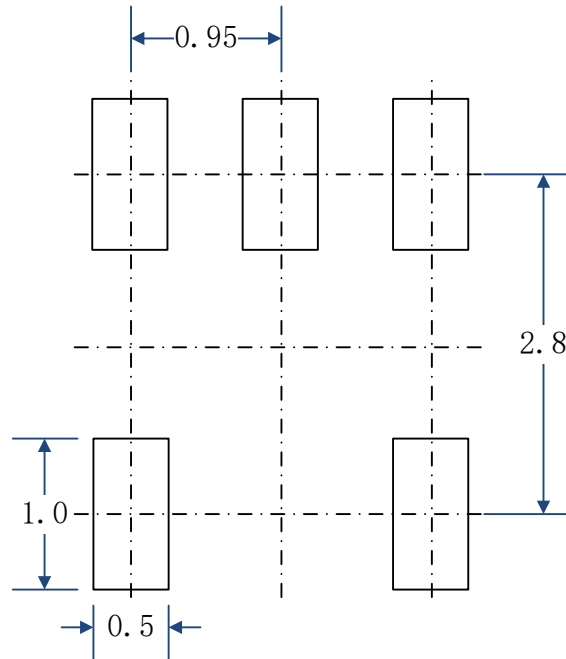

**DFN2x2-6L**

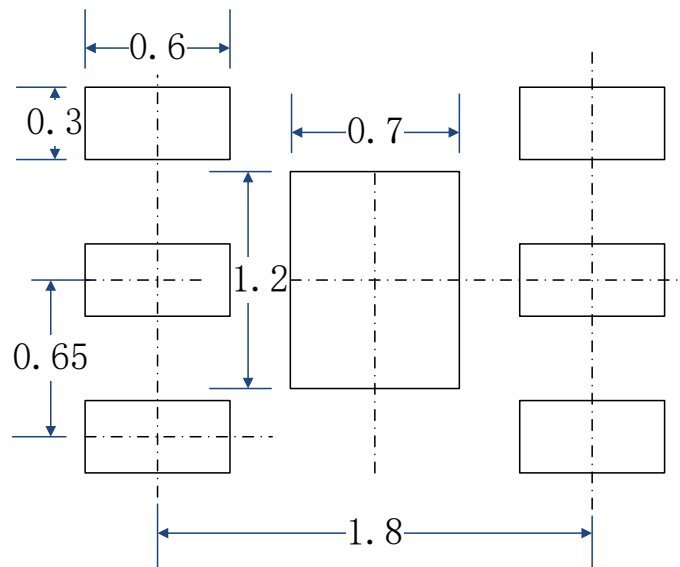

## X-ON Electronics

Largest Supplier of Electrical and Electronic Components

*Click to view similar products for [Linear Voltage Regulators](#) category:*

*Click to view products by [BROADCHIP](#) manufacturer:*

Other Similar products are found below :

[LV56831P-E](#) [LV5684PVD-XH](#) [MCDTSA6-2R](#) [L7815ACV-DG](#) [PQ3DZ53U](#) [LV56801P-E](#) [TLE42794G](#) [L78L05CZ/1SX](#) [L78LR05DL-MA-E](#) [636416C](#) [714954EB](#) [BA033LBSG2-TR](#) [LV5680P-E](#) [L78M15CV-DG](#) [TLS202B1MBV33HTSA1](#) [L79M05T-E](#) [TLS202A1MBVHTSA1](#) [L78LR05D-MA-E](#) [NCV317MBTG](#) [NTE7227](#) [LV5680NPVC-XH](#) [LT1054CN8](#) [MP2018GZD-5-Z](#) [MP2018GZD-33-Z](#) [MIC5281-3.3YMM](#) [RT9078-28GQZ](#) [MC78L06BP-AP](#) [TA48LS05F\(TE85L,F\)](#) [TA78L12F\(TE12L,F\)](#) [TC47BR5003ECT](#) [TCR2LN12,LF\(S](#) [TCR2LN28,LF\(S](#) [TCR2LN30,LF\(S](#) [TCR3DF295,LM\(CT](#) [TCR3DF40,LM\(CT](#) [BA178M20CP-E2](#) [L78M12ABDT](#) [LM7812SX/NOPB](#) [LR645N3-G-P003](#) [LR645N3-G-P013](#) [ZXTR2005P5-13](#) [SCD7812BTG](#) [TCR3DF335,LM\(CT](#) [ZXTR2012K-13](#) [TLE42994E V33](#) [ZXTR2008K-13](#) [ZXTR2005K-13](#) [LA5693D-E](#) [L88R05DL-E](#) [ADP3300ARTZ-2.7RL7](#)