



BCT2193

Low Power, Low Dropout RF-Linear Regulators

BCT2193

Low Power, Low Dropout, RF-Linear Regulators

GENERAL DESCRIPTION

The BCT2193 series low-power, low-dropout, CMOS linear voltage regulators operate from a 1.6V to 5.5V input voltage and deliver up to 500mA output current. They are the perfect choice for low voltage, low power applications. A low ground current makes this part attractive for battery operated power systems. The BCT2193 series also offer low dropout voltage to prolong battery life in portable electronics. Systems requiring a quiet voltage source, such as RF applications, will benefit from the BCT2193 series low output noise and high PSRR.

Other features include short current limit and thermal shutdown protection.

The BCT2193 is available in Green SOT23-3, SOT89-3 packages. It operates over an ambient temperature range of -40°C to +85°C .

FEATURES

- Low Dropout Voltage
- Thermal Overload Protection
- Built-In Fold Back Protection Circuit
- 20µA Low Supply Current
- 1.6V to 5.5V Input Voltage Range
- Fixed Outputs of 1.2V, 1.8V, 2.8V, 3.0V, and 3.3V
- 500mA Output Current
- High Output Voltage Accuracy
- -40°C to +85°C Operating Temperature Range Available in Green SOT23-3, SOT89-3 Packages.

APPLICATIONS

Cellular Telephones
Cordless Telephones
PCMCIA Cards
Modems
MP3 Player
Hand-Held Instruments
Palmtop Computers
Electronic Planners
Portable/Battery-Powered Equipment



BCT2193

Low Power, Low Dropout RF-Linear Regulators

ORDERING INFORMATION

Order Number	V _{OUT} (V)	Package Type	Temperature Range	Marking	QTY/Reel
BCT2193EUR12-TR	1.2	SOT23-3	-40°C to +85°C	V2XX	3000
BCT2193EUR18-TR	1.8	SOT23-3	-40°C to +85°C	V8XX	3000
BCT2193EUR28-TR	2.8	SOT23-3	-40°C to +85°C	V8XX	3000
BCT2193EUR30-TR	3.0	SOT23-3	-40°C to +85°C	V0XX	3000
BCT2193EUR33-TR	3.3	SOT23-3	-40°C to +85°C	V3XX	3000
BCT2193EJR12-TR	1.2	SOT89-3	-40°C to +85°C	2193 12XXX	3000
BCT2193EJR18-TR	1.8	SOT89-3	-40°C to +85°C	2193 18XXX	3000
BCT2193EJR28-TR	2.8	SOT89-3	-40°C to +85°C	2193 28XXX	3000
BCT2193EJR30-TR	3.0	SOT89-3	-40°C to +85°C	2193 30XXX	3000
BCT2193EJR33-TR	3.3	SOT89-3	-40°C to +85°C	2193 33XXX	3000

Note:

"V" in Marking is product short code for BCT2193

"XX" or "XXX" in Marking will be appeared as the batch code.



BCT2193

Low Power, Low Dropout RF-Linear Regulators

ABSOLUTE MAXIMUM RATINGS

IN to GND.....	-0.3V to 6.0V
Output Short-Circuit Duration.....	Infinite
EN to GND.....	-0.3V to 6.0V
OUT to GND.....	-0.3V to (VIN +0.3V)
Power Dissipation, P _D @T _A =25°C	
SOT23-3.....	0.42W
SOT89-3.....	1.25W
Package Thermal Resistance	
SOT23-3.....	300°C/W
SOT89-3, θ _{JA}	100°C/W
Junction Temperature.....	150°C
Storage Temperature Range.....	-65°C to 150°C
Lead Temperature (Soldering, 10 sec).....	260°C
ESD Susceptibility	
HBM.....	4000V
MM.....	400V

RECOMMENDED OPERATING CONDITIONS

Operating Voltage Range.....	1.6V to 5.5V
Operating Temperature Range	-40°C to +85°C

OVERSTRESS CAUTION

Stresses beyond those listed under “Absolute Maximum Ratings” may cause permanent damage to the device. These are stress ratings only, and functional operation of the device at these or any other conditions beyond those indicated in the operational sections of the specifications is not implied. Exposure to absolute maximum rating conditions for extended periods may affect device reliability.

ESD SENSITIVITY CAUTION

This integrated circuit can be damaged by ESD if you don't pay attention to ESD protection. Broadchip recommends that all integrated circuits be handled with appropriate precautions. Failure to observe proper handling and installation procedures can cause damage. ESD damage can range from subtle performance degradation to complete device failure. Precision integrated circuits may be more susceptible to damage because very small parametric changes could cause the device not to meet its published specifications.

DISCLAIMER

Broadchip reserves the right to make any change in circuit design, specification or other related things if necessary without notice at any time. Please contact Broadchip sales office to get the latest datasheet.

PIN CONFIGURATION (TOP VIEW)

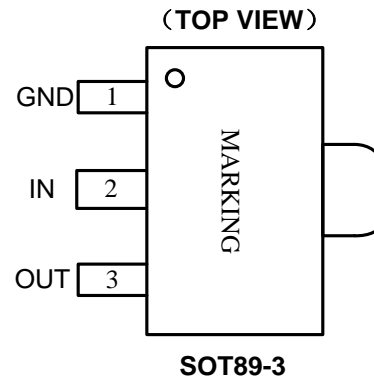
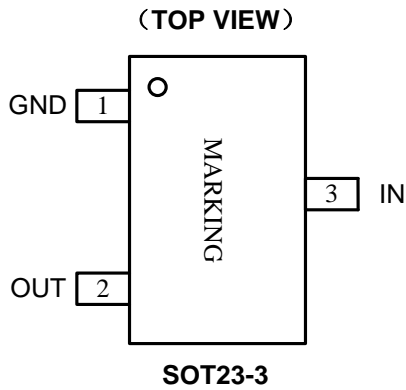

PIN DESCRIPTION

PIN		NAME	FUNCTION
SOT23-3	SOT89-3		
1	1	GND	Ground.
2	3	OUT	Regulator Output.
3	2	IN	Regulator Input. Supply voltage can range from 1.6V to 5.5V. Bypass with a 1 μ F capacitor to GND.

ELECTRICAL CHARACTERISTICS

($V_{IN} = V_{OUT(NOMINAL)} + 0.5V$ or $1.6V$, whichever is greater, Full = $-40^{\circ}C$ to $+85^{\circ}C$, unless otherwise noted.)

PARAMETER	SYMBOL	CONDITIONS	TEMP	MIN	TYP	MAX	UNITS
Input Voltage	V_{IN}		$+25^{\circ}C$	1.6		5.5	V
Output Voltage Accuracy		$I_{OUT} = 0.1mA$	$+25^{\circ}C$	-2.5		+2.5	%
Maximum Output Current (1)			$+25^{\circ}C$	500			mA
Current Limit	I_{LIM}		$+25^{\circ}C$	560	800		mA
Supply Pin Current	I_Q	No Load, $V_{EN} = V_{IN}$	$+25^{\circ}C$		20	26	μA
Dropout Voltage (2)	V_{DROP}	$I_{OUT} = 500mA$	$1.2V \leq V_{OUT} < 1.8V$	$+25^{\circ}C$	945	1280	mV
			$1.8V \leq V_{OUT} < 2.5V$	$+25^{\circ}C$	510	670	
			$2.5V \leq V_{OUT} < 3.0V$	$+25^{\circ}C$	345	450	
			$3.0V \leq V_{OUT} < 3.6V$	$+25^{\circ}C$	305	400	
Line Regulation	$\frac{\Delta V_{OUT}}{\Delta V_{IN} \times V_{OUT}}$	$V_{IN} = 1.6V$ or $(V_{OUT} + 0.5V)$ to $5.5V$, $I_{OUT} = 1mA$	$1.8V \leq V_{OUT} \leq 3.3V$	$+25^{\circ}C$	0.01	0.06	%/ V
			$V_{OUT} < 1.8V$ or $V_{OUT} > 3.3V$	$+25^{\circ}C$	0.01	0.1	
Load Regulation	ΔV_{OUT}	$I_{OUT} = 0.1mA$ to $500mA$	$+25^{\circ}C$		12	40	mV
Short Current Limit	I_{SHORT}	$V_{OUT} = 0V$	$+25^{\circ}C$		320		mA
Power Supply Rejection Ratio	PSRR	$I_{OUT} = 30mA$, $C_{OUT} = 1\mu F$, $V_{IN} = V_{OUT} + 1V$, $\Delta V_{RIPPLE} = 0.2V_{P-P}$	$f = 217Hz$	$+25^{\circ}C$	80		dB
			$f = 1kHz$	$+25^{\circ}C$	70		
Output Voltage Noise	e_n	$f = 10Hz$ to $100kHz$, $C_{OUT} = 1\mu F$, $V_{OUT} = 1.8V$	$I_{OUT} = 0mA$	$+25^{\circ}C$	100		μV_{RMS}
			$I_{OUT} = 30mA$	$+25^{\circ}C$	200		
Output Voltage Temperature Coefficient (3)	$\frac{\Delta V_{OUT}}{\Delta T_A \times V_{OUT}}$	$I_{OUT} = 0.1mA$	Full		30		ppm/ $^{\circ}C$
THERMAL PROTECTION							
Thermal Shutdown Temperature	T_{SHDN}				140		$^{\circ}C$
Thermal Shutdown Hysteresis	ΔT_{SHDN}				15		$^{\circ}C$

NOTES:

- Maximum output current is affected by the PCB layout, size of metal trace, the thermal conduction path between metal layers, ambient temperature and the other environment factors of system. Attention should be paid to the dropout voltage when $V_{IN} < V_{OUT} + V_{DROP}$.
- The dropout voltage is defined as $V_{IN} - V_{OUT}$, when V_{OUT} is 100mV below the value of V_{OUT} .
- Output voltage temperature coefficient is defined as the worst-case voltage change divided by the total temperature range.

TYPICAL APPLICATION CIRCUIT

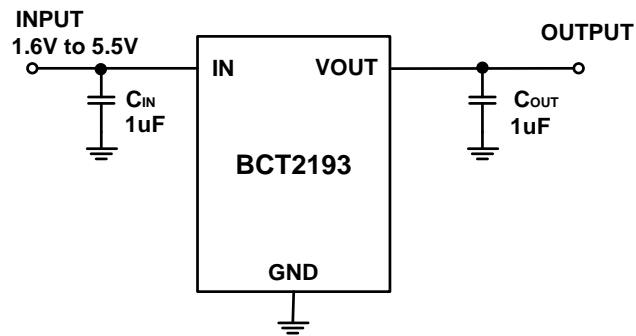

SOT23-3/SOT89-3

PACKAGE OUTLINE DIMENSIONS

SOT23-3

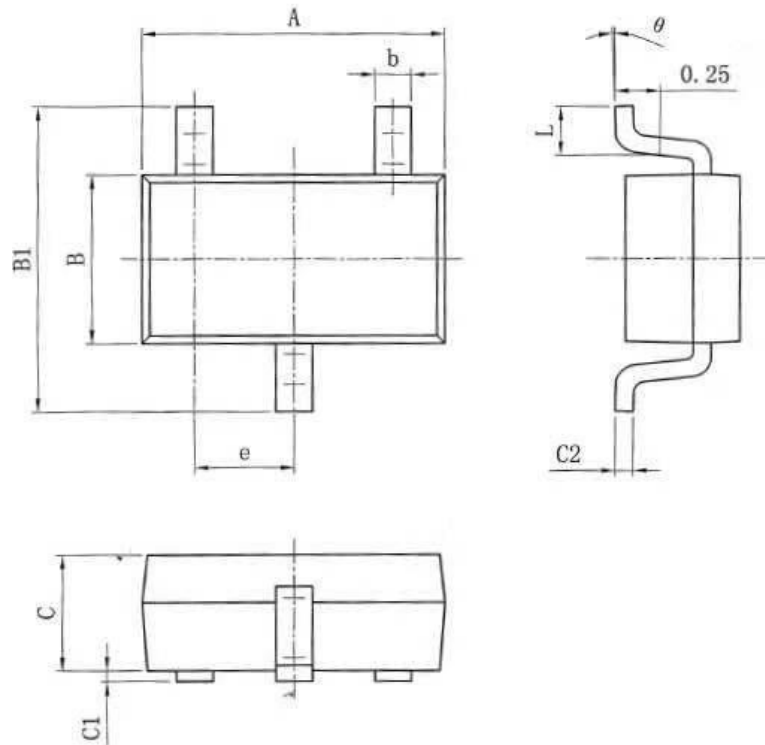

Symbol	Dimensions In Millimeters	
	Min	Max
A	2.82	3.02
e	0.95(BSC)	
b	0.28	0.45
B	1.50	1.70
B1	2.75	3.05
C	1.05	1.15
C1	0.03	0.15
C2	0.12	0.23
L	0.35	0.55
θ	0°	8°

SOT23-3 Surface Mount Package

SOT89-3

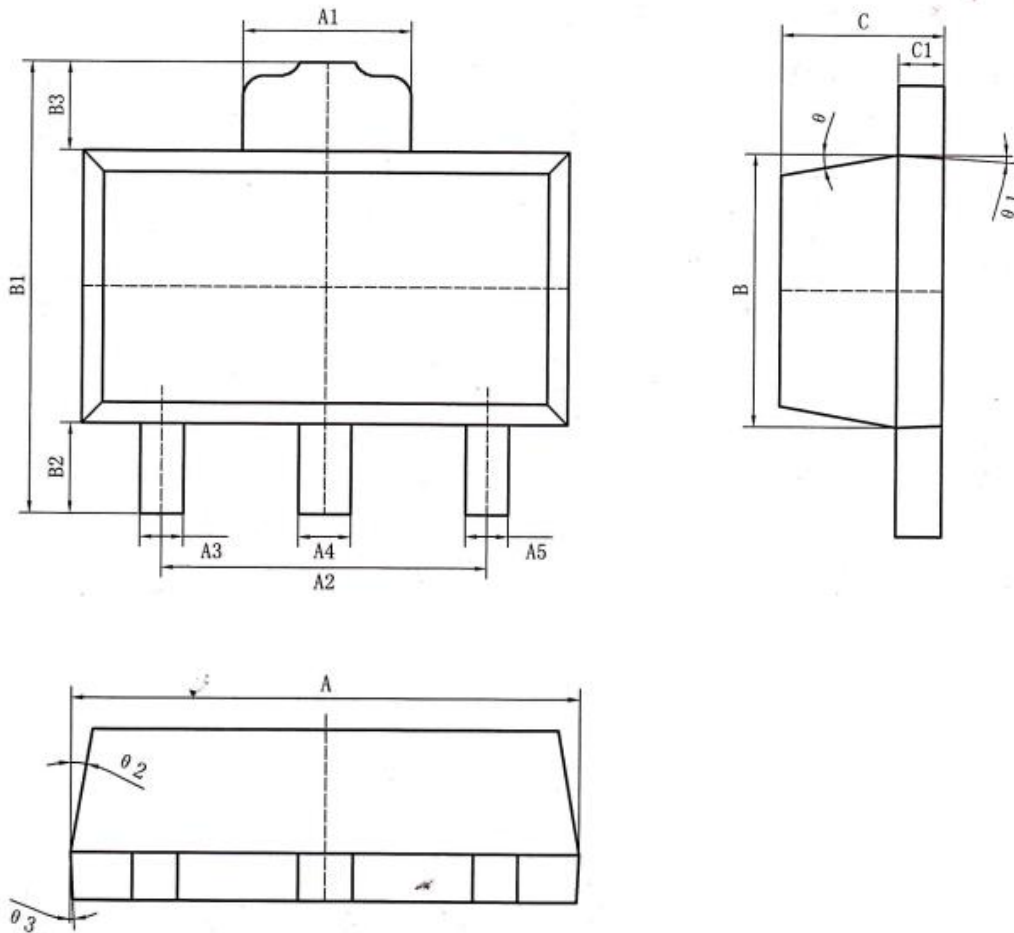

标注	尺寸	最小 (mm)	最大 (mm)	标注	尺寸	最小 (mm)	最大 (mm)
A		4.40	4.60	B3		0.82	0.83
A1		1.65	1.75	C		1.40	1.60
A2		2.95	3.05	C1		0.35	0.45
A3		0.35	0.45	theta		6° TYP4	
A4		0.43	0.53	theta 1		3° TYP4	
A5		0.35	0.45	theta 2		6° TYP4	
B		2.40	2.60	theta 3		3° TYP4	
B1		4.05	4.25				
B2		0.82	0.83				

SOT89-3 Surface Mount Package

LAND PATTERN DATA

SOT23-3

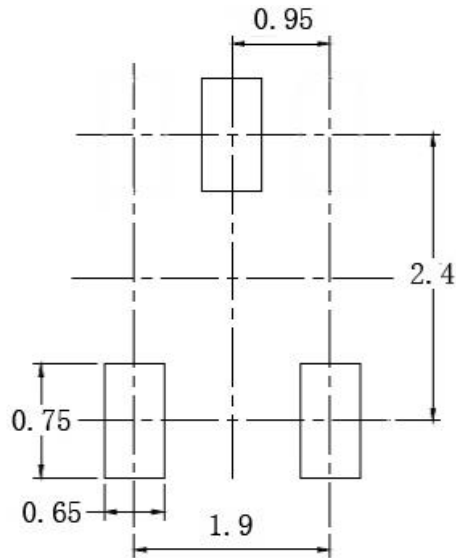

RECOMMENDED PCB LAYOUT PATTERN (Unit: mm)

SOT89-3

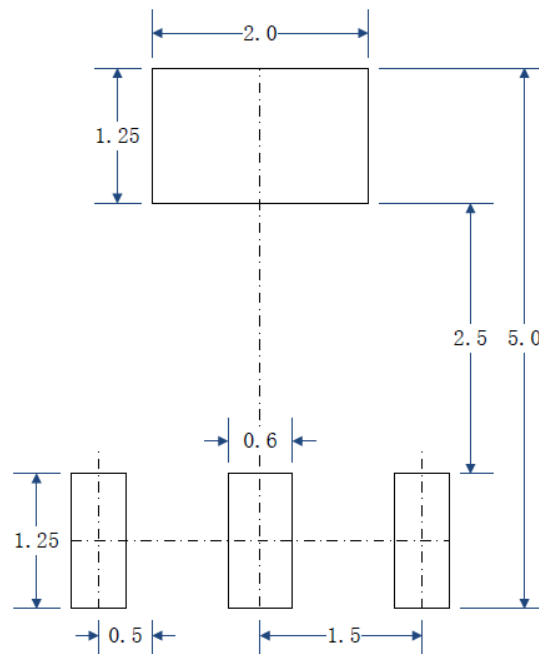

RECOMMENDED PCB LAYOUT PATTERN (Unit: mm)

X-ON Electronics

Largest Supplier of Electrical and Electronic Components

Click to view similar products for [Linear Voltage Regulators](#) category:

Click to view products by [BROADCHIP](#) manufacturer:

Other Similar products are found below :

[LV56831P-E](#) [LV5684PVD-XH](#) [MCDTSA6-2R](#) [L7815ACV-DG](#) [PQ3DZ53U](#) [LV56801P-E](#) [TLE42794G](#) [L78L05CZ/1SX](#) [L78LR05DL-MA-E](#) [636416C](#) [714954EB](#) [BA033LBSG2-TR](#) [LV5680P-E](#) [L78M15CV-DG](#) [TLS202B1MBV33HTSA1](#) [L79M05T-E](#) [TLS202A1MBVHTSA1](#) [L78LR05D-MA-E](#) [NCV317MBTG](#) [NTE7227](#) [LV5680NPVC-XH](#) [LT1054CN8](#) [MP2018GZD-5-Z](#) [MP2018GZD-33-Z](#) [MIC5281-3.3YMM](#) [MC78L06BP-AP](#) [TA48LS05F\(TE85L,F\)](#) [TA78L12F\(TE12L,F\)](#) [TC47BR5003ECT](#) [TCR2LN12,LF\(S](#) [TCR2LN28,LF\(S](#) [TCR2LN30,LF\(S](#) [TCR3DF295,LM\(CT](#) [TCR3DF40,LM\(CT](#) [BA178M20CP-E2](#) [L78M12ABDT](#) [LM7812SX/NOPB](#) [LR645N3-G-P003](#) [LR645N3-G-P013](#) [ZXTR2005P5-13](#) [SCD7812BTG](#) [TCR3DF335,LM\(CT](#) [ZXTR2012K-13](#) [TLE42994E V33](#) [ZXTR2008K-13](#) [ZXTR2005K-13](#) [L88R05DL-E](#) [ADP3300ARTZ-2.7RL7](#) [LM120K-15/883](#) [IFX54441LDVXUMA1](#)