

BCT3119

9-Channel 64steps Constant-Current LED Driver with SPI Control

General Description

The BCT3119 is a constant current driver incorporating shift register and data latch. This CMOS device is designed for LED display applications.

The max output constant current can be set using an external resistor, and 64 steps of current could be set through a SPI interface with MCU. Any channel output could have any step current levels.

Applications

- Cell Phones
- Multicolor LED lighting
- Display backlighting
- Toys/Mp3/Mp4/CD/minidiskplayers

Features

- ◆ 9 channel constant-current outputs, up to 40mA each
- ◆ Each channel current could be controlled through a SPI interface with MCU
- ◆ Power-On Reset(POR), all register bits=0
- ◆ For common-anode LEDs
- ◆ High data input rate: < 20MHz
- ◆ 2.7V to 5.5V Supply Voltage Range
- ◆ RoHS Compliant and 100% Lead (Pb)-Free

Pin Configurations (Top view)

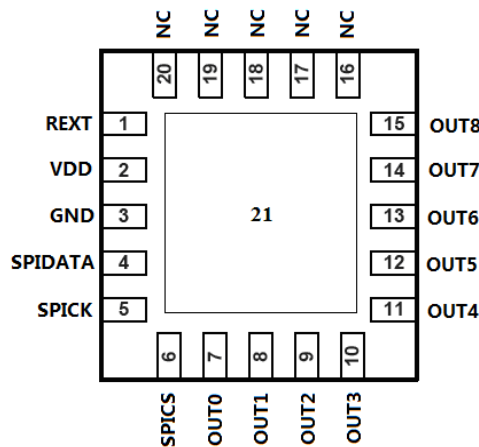

Ordering Information

PART	PIN-PACKAGE	Temp-Range	Top Mark
BCT3119EGP-TR	QFN-20 (3x3mm)	-40°C to +85°C	3119

9-Channel 64steps Constant-Current LED Driver

Functional Pin Description

Pin	Name	Function
1	REXT	Reference current terminal; set maximum output current for all channels
2	VDD	Logic Supply terminal
3	GND	Logic supply ground and load supply ground
4	SPIDATA	Serial bus data input
5	SPICK	Serial bus clock input
6	SPICS	Serial bus selection input
7 to 15	OUT0 to OUT8	Constant current outputs
16 to 20	NC	No connect

Absolute Maximum Ratings

Characteristic	Symbol	Notes	Rating	Unit
Supply Voltage	VDD		-0.3 to 5.5	V
OUTx Current(any single output)	IO		40	mA
Input Voltage Range	VI	VSPI	-0.3 to VDD+0.3	V
Operating Temperature Range	TA		-40 to 85	°C
Junction Temperature	TJ(max)		150	°C
Storage Temperature Range	Tstg		-55 to 150	°C

Note: "Absolute Maximum Ratings" may cause permanent damage to the device. This is a stress only rating and operation of the device at these or any other conditions beyond those indicated in the operational sections of this specification is not implied

Typical Application Circuit

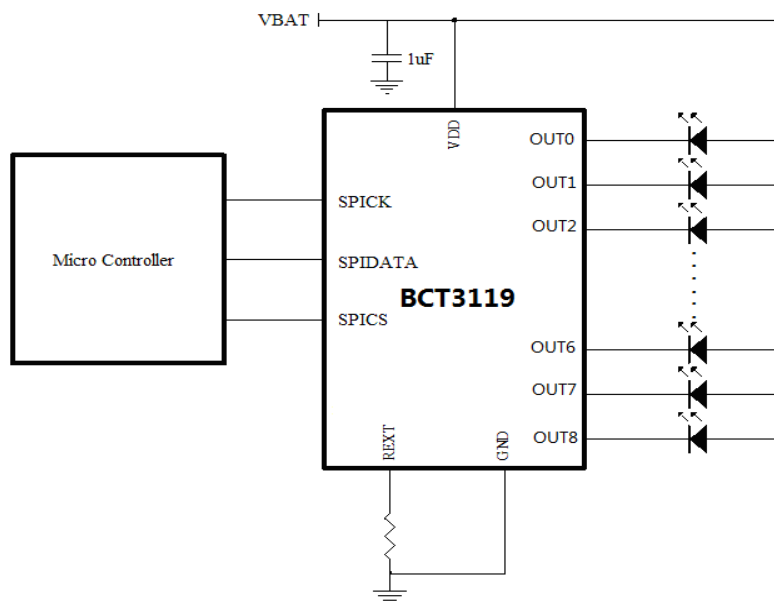

9-Channel 64steps Constant-Current LED Driver

ELECTRICAL CHARACTERISTICS

(VIN = 2.7V to 5.5V, TA =25°C, unless otherwise noted)

PARAMETER	SYMBOL	CONDITIONS	MIN	TYP	MAX	UNITS
Supply Voltage Range	VDD	operating	2.7		5.5	V
Supply Current	I _{VDD}	REXT=4K, Out0~Out8 NC, VDD=5.5V		1.6	2	mA
Shut Down Current	ISHUT	System enter shutdown mode, VDD=5.5V			2	uA
Output current accuracy	I _o	REXT=2K , Vdropout=1V	35	40	45	mA
		REXT=4K , Vdropout=1V	18	20	22	
Output current match		REXT=2K , Vdropout =1V , I _o =40mA		±1	±3	%
		REXT=4K , Vdropout =1V , I _o =20mA		±1	±3	
Dropout voltage	Vdrop	VDD=3.3V , I _o =40mA		400	500	mV
		VDD=3.3V , I _o =20mA		300	500	
Logic Input-Logic High	V _{IH}		1.5			V
Logic Input-Logic Low	V _{IL}				0.7	V

Serial Port Interface (SPI)

This module is used to receive the commands transmitted by Micro Controller. It will decode the received data and send corresponding commands to signal processing and analog blocks. The 16-bit serial interface uses three pins –“SPICS/SPIDATA / SPICK” to enter data. Data read is not available with the serial interface and data entered must be 16 bits.

The description of three pins is:

Signal Name	Attribute	Direction	Description
SPICK	Edge Triggered	MCU->BCT3119	Serial bus clock
SPIDATA	Level	MCU->BCT3119	Serial data
SPICS	Active Low	MCU->BCT3119	SPI bus selection

9-Channel 64steps Constant-Current LED Driver

Figure 2 shows the timing diagram of this serial interface. When the block is idle, SPICK is forced LOW and SPICS is forced HIGH. Once the data register contains data and the interface is enabled, SPICS is pulled LOW and remains LOW for the duration of the transmission.

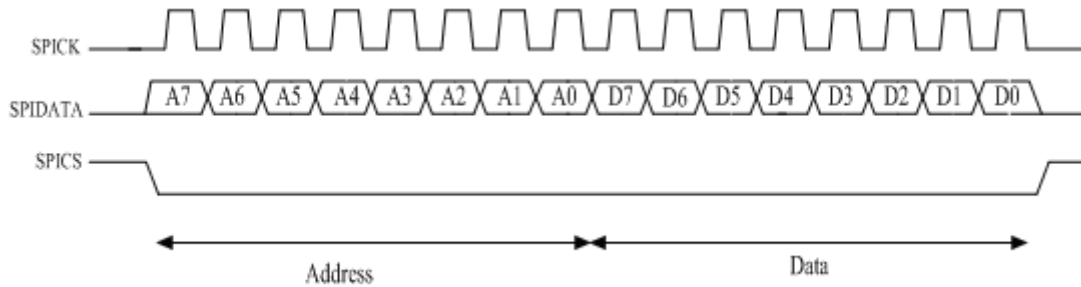

Figure 2. SPI Interface Transfer Diagram(normal operation)

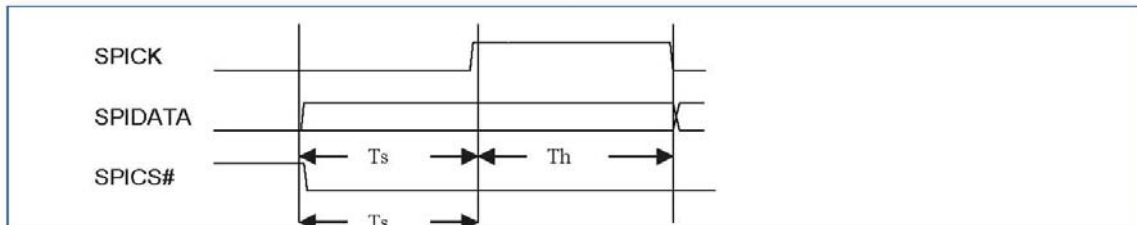

Figure 3. SPI Interface Timing Diagram

Serial Port Interface Timing

Symbol	Parameter	Min	Tye	Max	Unit
Ts	SPIDATA to SPICK setup time	4			ns
Th	SPIDATA to SPICK hold time	20			ns

Register Definitions

Output Channel Control Register

A7	A6	A5	A4	A3	A2	A1	A0	Output Channel
0	0	0	0	0	0	0	0	Out0
0	0	0	0	0	0	0	1	Out1
0	0	0	0	0	0	1	0	Out2
0	0	0	0	0	0	1	1	Out3
0	0	0	0	0	1	0	0	Out4
0	0	0	0	0	1	0	1	Out5
0	0	0	0	0	1	1	0	Out6
0	0	0	0	0	1	1	1	Out7
0	0	0	0	1	0	0	0	Out8

9-Channel 64steps Constant-Current LED Driver

DIMMING Control Register

D7	D6	D5	D4	D3	D2	D1	D0	Status
0	0	0	0	0	0	0	0	off
0	0	0	0	0	0	0	1	2/64 max
0	0	0	0	0	0	1	0	3/64 max
0	0	0	0	0	0	1	1	4/64 max
0	0	0	0	0	1	0	0	5/64 max
0	0	0	0	0	1	0	1	6/64 max
0	0	0	0	0	1	1	0	7/64 max
0	0	0	0	0	1	1	1	8/64 max
...
0	0	1	1	1	0	0	1	58/64 max
0	0	1	1	1	0	1	0	59/64 max
0	0	1	1	1	0	1	1	60/64 max
0	0	1	1	1	1	0	0	61/64 max
0	0	1	1	1	1	0	1	62/64 max
0	0	1	1	1	1	1	0	63/64 max
0	0	1	1	1	1	1	1	64/64 max

Note: “n/64 max” means $\text{Output Current} = (\text{max current value} \times n) \div 64$

SHUTDOWN MODE CONTROL REGISTER

A7	A6	A5	A4	A3	A2	A1	A0	System enter shutdown mode
1	1	1	1	1	1	1	1	
D7	D6	D5	D4	D3	D2	D1	D0	
0	0	0	0	0	0	0	0	

Maximum output current setting

The maximum output current per channel is set by a single external resistor, REXT, which is placed between the REXT pin and GND pin. The maximum channel output current can be calculated as:

$$I_o(\text{max}) = 0.4 * 200 / \text{REXT}$$

The max output current REXT values

REXT(K Ω)	IOmax(mA)
2	40
3	27
4	20
5	16

9-Channel 64steps Constant-Current LED Driver

Package Information

PIN 1 DOT
BY MARKING

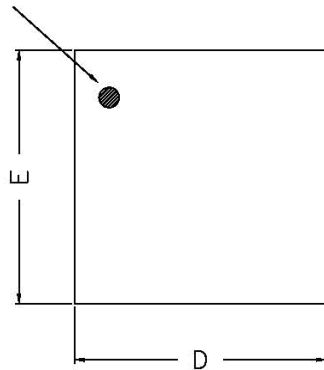

TOP VIEW

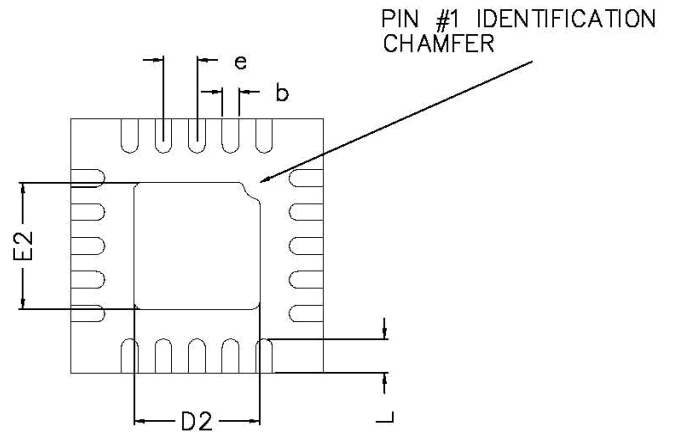

BOTTOM VIEW

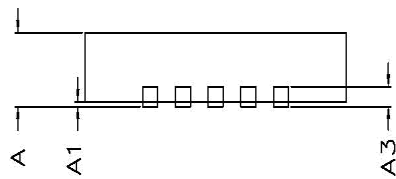

SIDE VIEW

COMMON DIMENSIONS(MM)			
PKG.	W: VERY VERY THIN		
REF.	MIN.	NOM.	MAX
A	0.70	0.75	0.80
A1	0.00	—	0.05
A3	0.2 REF.		
D	2.95	3.00	3.05
E	2.95	3.00	3.05
b	0.15	0.20	0.25
L	0.30	0.40	0.50
D2	1.35	1.50	1.60
E2	1.35	1.50	1.60
e	0.40 BSC		

X-ON Electronics

Largest Supplier of Electrical and Electronic Components

Click to view similar products for [LED Display Drivers](#) category:

Click to view products by [BROADCHIP](#) manufacturer:

Other Similar products are found below :

[STP16CPP05XTTR](#) [SCT2027CSSG](#) [KP22306WGA](#) [WS9088AS7P](#) [GN1628T](#) [BCT3236EGH-TR](#) [HT1628BRWZ](#) [KP1192SPA](#) [KP1182SPA](#)
[KP1262FSPA](#) [KP1072LSPA](#) [KP1191SPA](#) [KP18001WPA](#) [KP1221SPA](#) [GN1640T](#) [MBI5253GP-A](#) [MBI5124GM-B](#) [WS90561T](#) [S7P](#)
[WS9821B](#) [S7P](#) [WS9032GS7P](#) [LYT3315D](#) [M08888G-11](#) [M08890G-13](#) [BCR420U](#) [SCT2001ASIG](#) [SCT2024CSOG](#) [SCT2024CSSG](#)
[SCT2167CSSG](#) [AL8400QSE-7](#) [PR4401](#) [PR4403](#) [PCA9685PW](#) [STP16CPC05XTTR](#) [WS2821B](#) [PR4402](#) [M08898G-13](#) [RT8471GJ5](#)
[RT9284A-20GJ6E](#) [TLC59482DBQR](#) [ISL97634IRT14Z-TK](#) [AW36413CSR](#) [LP5562TMX](#) [DLD101Q-7](#) [WS2818B](#) [BCR401U](#) [BCR402U](#)
[SCT2004CSOG](#) [SCT2026CSSG](#) [SCT2026CSTG](#) [SCT2110CSSG](#)