

BCT3220

4 Channel LED Driver (Common-Anode & Common-Cathode) Low Dropout Current Source & Current Sink

General Description

The BCT3220 is a high performance white LED driver. The BCT3220 uses an internal resistor to set the bias current for four LEDs, which are matched to +/-1.5%. The BCT3220's advantages over ballast resistors include much lower bias variation with supply voltage variation, significantly lower dropout voltage, and in some applications, significantly improved efficiency. The BCT3220 requires only a 50mV dropout voltage at a 20mA load on each output to match the LED brightness.

By using one SEL pin, the BCT3220 can support to drive 4 parallel Co-Anode or Co-Cathode white LEDs and regulates a constant current for uniform intensity.

Users can easily configure the LED current from 2.5mA to 20mA by a serial pulse. The dimming of white LEDs current can be achieved by applying a pulse signal to the EN pin. There are totally 8 steps of current could be set by users. Internal soft start circuitry effectively reduces the in-rush current while both start-up and mode transition.

Features

- ◆ Drive Common Anode or Common Cathode LEDs
- ◆ Low 50mV Dropout at 20mA
- ◆ 20mA full scale current
- ◆ <2% LED Current Matching (TYP)
- ◆ One Wire interface for 8-Step Brightness Control
- ◆ 2.7V to 5.5V Supply Voltage Range
- ◆ Thermal Shutdown Protection
- ◆ Low Input Noise and EMI
- ◆ RoHS Compliant and 100% Lead (Pb)-Free, DFN-8L Package

Applications

Cell Phones
PDAs
Digital Cameras, Camcorders
Portable Instrumentation
Battery Powered Equipment

Pin Configurations (Top View)

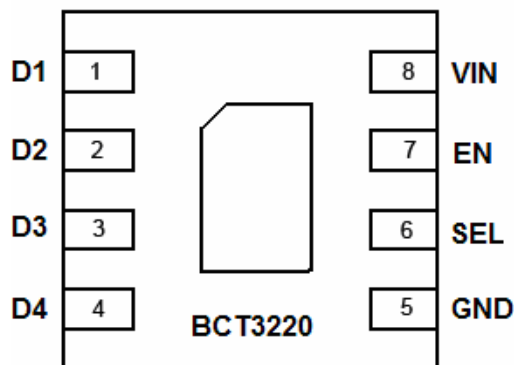

DFN2x2-8L Package

4 Channel LED Driver (Common-Anode & Common-Cathode)

Ordering Information

PART	PIN-PACKAGE	Temp-Range	Top Mark	Supplied as:
BCT3220ELA-TR	DFN2x2-8L	-40°C to +85°C	BCT3220	3000units/Tape & Reel

Functional Pin Description

Pin	Name	Function
1	D1	LED Pin1, leave it NC if unused.
2	D2	LED Pin2, leave it NC if unused.
3	D3	LED Pin3, leave it NC if unused.
4	D4	LED Pin4, leave it NC if unused.
5	GND	Ground
6	SEL	When SEL is Low, it's a Co-Anode LED driver (see Figure 1). When SEL is High, it's a Co-Cathode LED driver (see Figure 2).
7	EN	Chip Enable (Active High), and connects to GPIO pin of MCU.
8	VIN	Input voltage

Typical Application Circuit

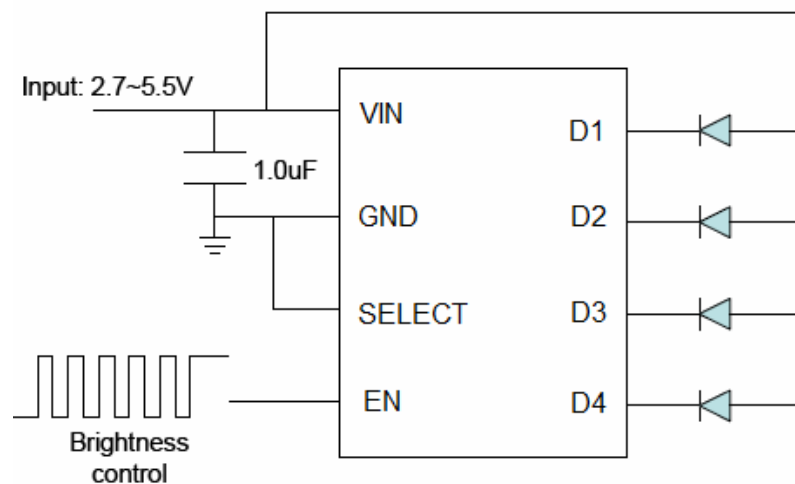

Figure 1: Application Circuit for Co-Anode Connection.

4 Channel LED Driver (Common-Anode & Common-Cathode)

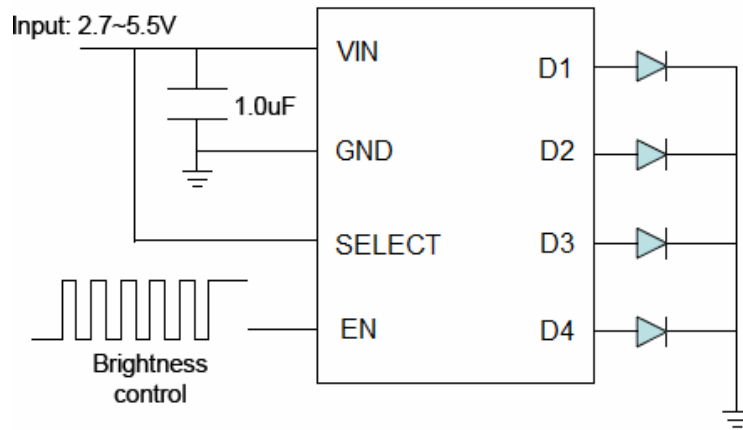

Figure 2: Application Circuit for Co-Cathode Connection.

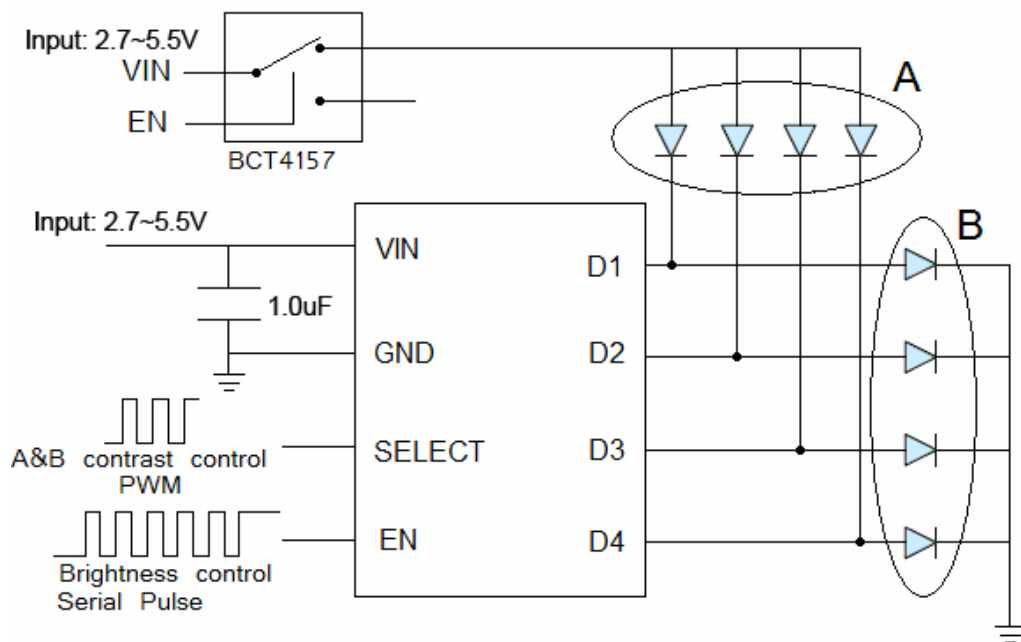

Figure 3: Application Circuit for Co-Anode & Co-Cathode Connection.

4 Channel LED Driver (Common-Anode & Common-Cathode)

ABSOLUTE MAXIMUM RATINGS

VIN to GND.....-0.3V to 6V	Operating Temperature
All Other Pins to GND-0.3V to (VCC + 0.3V)	Range-40°C to +85°C
Continuous Current (D1- D4)..... ±30mA	Storage Temperature
Continuous Power Dissipation (TA = +70°C)	Range.....-65°C to +150°C
8-Pin DFN (derate 10.5mW/°C above	Junction Temperature.....+150°C
+70°C)0.84W	Lead Temperature (soldering, 10s)...+300°C

Stresses beyond those listed under "Absolute Maximum Ratings" may cause permanent damage to the device. These are stress ratings only, and functional operation of the device at these or any other conditions beyond those indicated in the operational sections of the specifications is not implied. Exposure to absolute maximum rating conditions for extended periods may affect device reliability.

ELECTRICAL CHARACTERISTICS

(VIN = 2.7V to 5.5V, TA = TMIN to TMAX, unless otherwise noted. Typical values are at VIN = 3.3V, TA = +25°C.)

PARAMETER	SYMBOL	CONDITIONS	MIN	TYP	MAX	UNITS
POWER SUPPLY						
Supply Voltage Range	VIN		2.7		5.5	V
Supply Current	I _{VIN}	EN= high, SEL= '0' or '1', D_ floating		150	200	uA
Shut Down Current	I _{SHUT}	EN= low			1	uA
Analog Outputs (D1-D4)						
Drop Out Voltage (Current Source mode)	V _{DROP1}	SEL=1, ID_ = 20mA, VIN- VD_		60	80	mV
Drop Out Voltage (Current Sink mode)	V _{DROP2}	SEL=0, ID_ = 20mA, VD_ - GND		55	75	mV
Current Accuracy	ID_	Current Source or Sinck mode	18	20	22	mA
Current Matching Between Channels	Δ ID_	Max(Δ ID_) /I _{avg} , Current Source or Sinck mode		1.5	3	%
Logic Inputs (EN, SEL)						
Input-Logic High	V _{IH}		1.4			V
Input-Logic Low	V _{IL}				0.4	V
Input Leakage Current	I _{IN}	V(EN or SEL) = 0 or VIN			±1	uA
IC junction thermal shutdown threshold	T _{J-TH}			155		°C

Note : Devices are 100% tested at TA = +25°C. Limits across the full temperature range are guaranteed by design and correlation.

4 Channel LED Driver (Common-Anode & Common-Cathode)

Functional Block Diagram

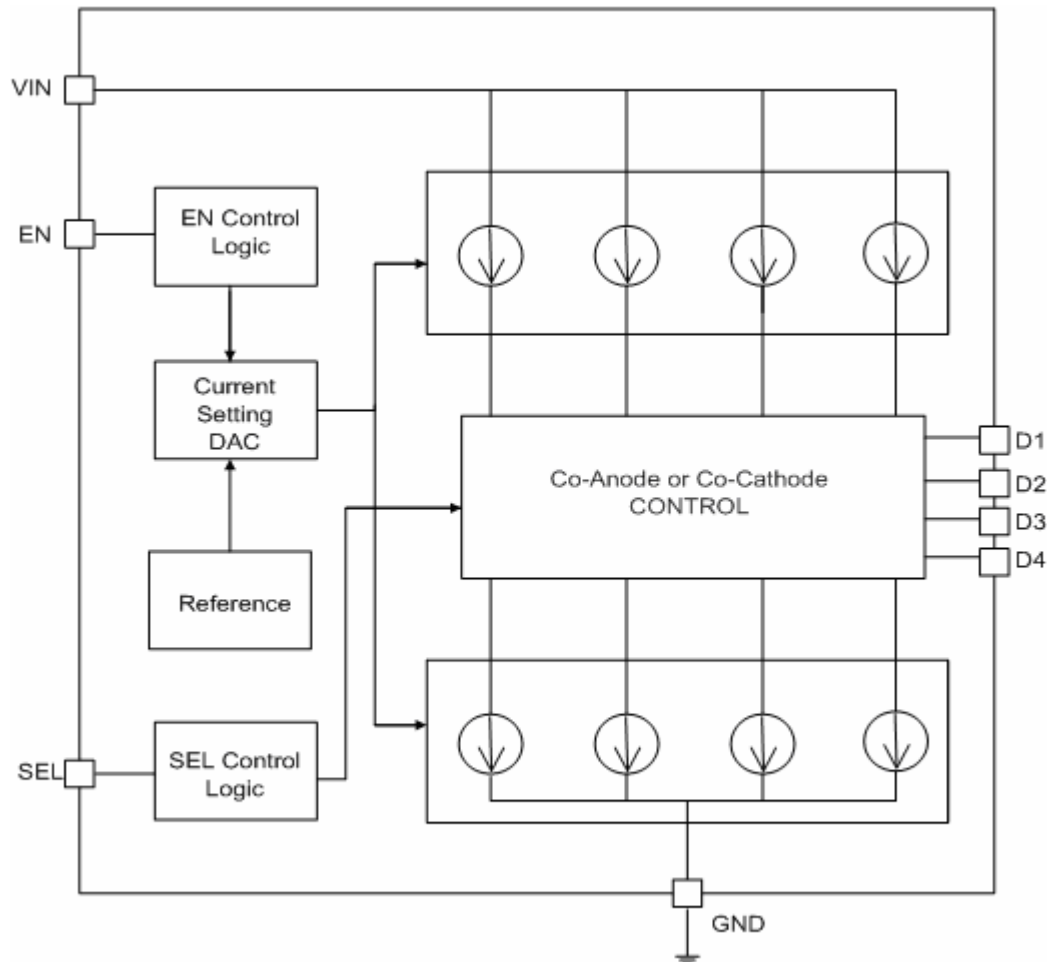

Functional Description

The BCT3220 is a four-channel current sink and current source driver, offering ultra-high efficiency for driving parallel LEDs. When pin SEL is low, The BCT3220 enters current sink mode and can support to drive 4 parallel Co-Anode LEDs, when pin SEL is high, The BCT3220 enters current source mode and can drive 4 Co-Cathode LEDs. Also users can easily configure the LED current from 2.5mA to 20mA by a serial pulse input pin(EN), so the dimming of white LEDs current can be achieved by applying a pulse signal to the EN pin. The number of falling edges are detected internally and decoded as illustrated in Table 1. There are totally 8 steps of current value could be set by users. When the EN pin is held low for 180us or more, the BCT3220 enters the shutdown mode and draw “zero” current from VIN.

4 Channel LED Driver (Common-Anode & Common-Cathode)

Number of Pulse Falling Edge	I_DX (mA)
0	20
1	17.5
2	15
3	12.5
4	10
5	7.5
6	5
7	2.5

Table 1: Current Setting

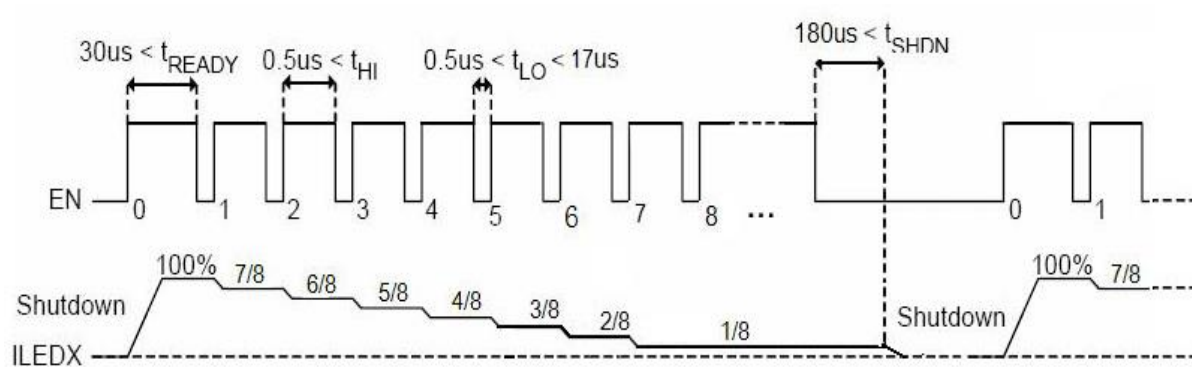
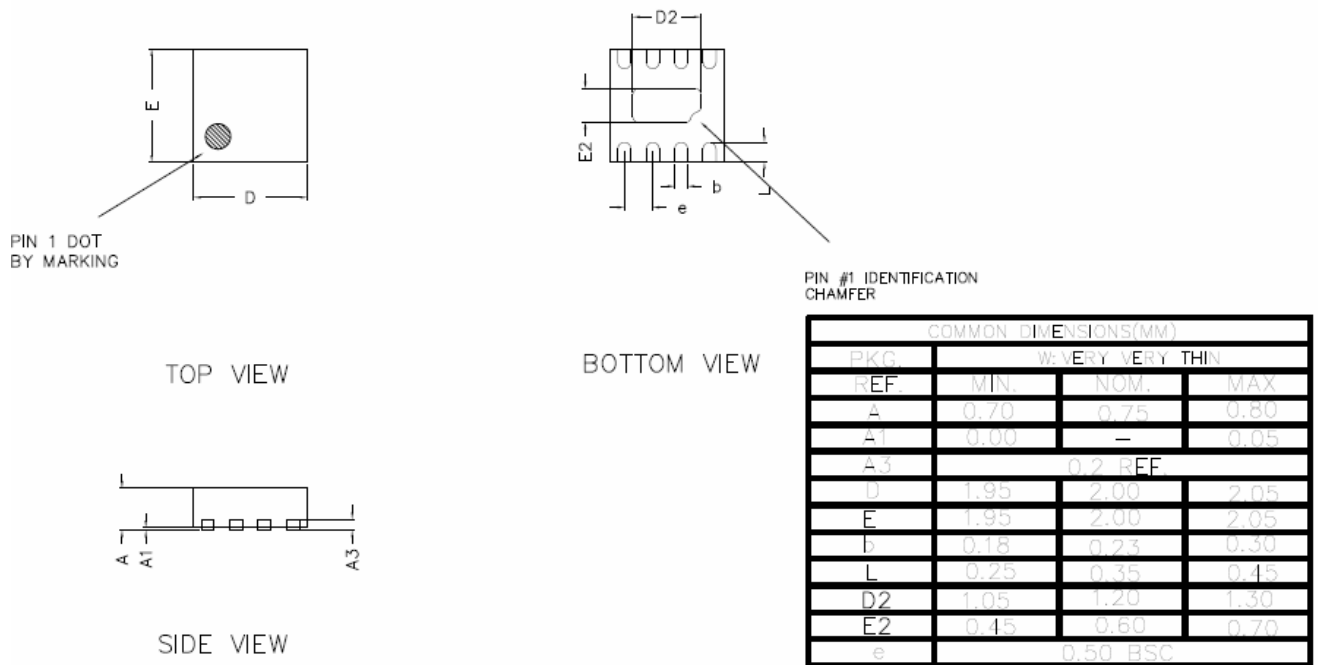

Figure 4: Brightness Control by Pulse Dimming

4 Channel LED Driver (Common-Anode & Common-Cathode)

Package Information:



DFN2x2-8L

X-ON Electronics

Largest Supplier of Electrical and Electronic Components

Click to view similar products for [LED Display Drivers](#) category:

Click to view products by [BROADCHIP](#) manufacturer:

Other Similar products are found below :

[STP16CPP05XTTR](#) [SCT2027CSSG](#) [KP22306WGA](#) [KP1199AWPA](#) [KP1199BWPA](#) [WS9088AS7P](#) [GN1628T](#) [BCT3236EGH-TR](#)
[HT1628BRWZ](#) [KP1192SPA](#) [KP1182SPA](#) [KP1262FSPA](#) [KP1072LSPA](#) [KP1191SPA](#) [KP18001WPA](#) [KP1070LSPA](#) [KP1221SPA](#)
[KP107ALSPA](#) [GN1640T](#) [MBI5253GP-A](#) [MBI5124GM-B](#) [WS90561T S7P](#) [WS9821B S7P](#) [WS9032GS7P](#) [LYT3315D](#) [M08888G-11](#)
[M08890G-13](#) [SCT2001ASIG](#) [SCT2024CSOG](#) [SCT2024CSSG](#) [AL8400QSE-7](#) [PR4401](#) [PR4403](#) [PCA9685PW](#) [STP16CPC05XTTR](#)
[WS2821B](#) [PR4402](#) [M08898G-13](#) [RT8471GJ5](#) [RT9284A-20GJ6E](#) [TLC59482DBQR](#) [ISL97634IRT14Z-TK](#) [AW36413CSR](#) [LP5562TMX](#)
[WS2818B](#) [BCR401R](#) [BCR401U](#) [BCR402U](#) [SCT2004CSOG](#) [SCT2026CSOG](#)