



BCT4005

Ultra Low ON-Resistance, Low Voltage, Dual, SPDT Analog Switch

BCT4005

Ultra Low ON-Resistance, Low Voltage, Dual, SPDT Analog Switch

GENERAL DESCRIPTION

The BCT4005 is a high-performance, dual single-pole double-throw (SPDT) analog switch. Specified over a wide operating power supply voltage range, 1.65V to 5.0V, Targeted applications include battery powered equipment that benefit from ultra-low ON-resistance (0.4Ω) and fast switching speeds.

Break-before-make switching prevents both switches being enabled simultaneously. This eliminates signal disruption during switching.

FEATURES

- ◆ Wide VCC Range: 1.65V to 5.0V
- ◆ Low ON Resistance: 0.4 Ω at 5.0V
- ◆ ON-Resistance Matching: 0.04 Ω (TYP)
- ◆ ON-Resistance Flatness: 0.08Ω (TYP)
- ◆ Rail-to-Rail Signal Range
- ◆ Break-Before-Make Switching
- ◆ Fast Switching time
 - $T_{ON} = 10\text{ns}$
 - $T_{OFF} = 7\text{ns}$
- ◆ -3dB Bandwidth: 70 MHz
- ◆ Temperature Range: -40°C to 85°C
- ◆ Packaging (Pb-free & Green available):

APPLICATIONS

- ◆ Cell Phones
- ◆ PDAs
- ◆ Portable Instrumentation
- ◆ Battery Powered Communications
- ◆ Computer Peripherals

ORDERING INFORMATION

Order Number	Package Type	Temperature Range	Marking	QTY/Reel
BCT4005ELB-TR	DFN3x3-10L	-40°C to +85°C	4005 XXXXX	3000
BCT4005EMB-TR	MSOP10	-40°C to +85°C	4005 XXXXX	4000

Note: "XXXXX" in Marking will be appeared as the batch code.

PIN CONFIGURATION

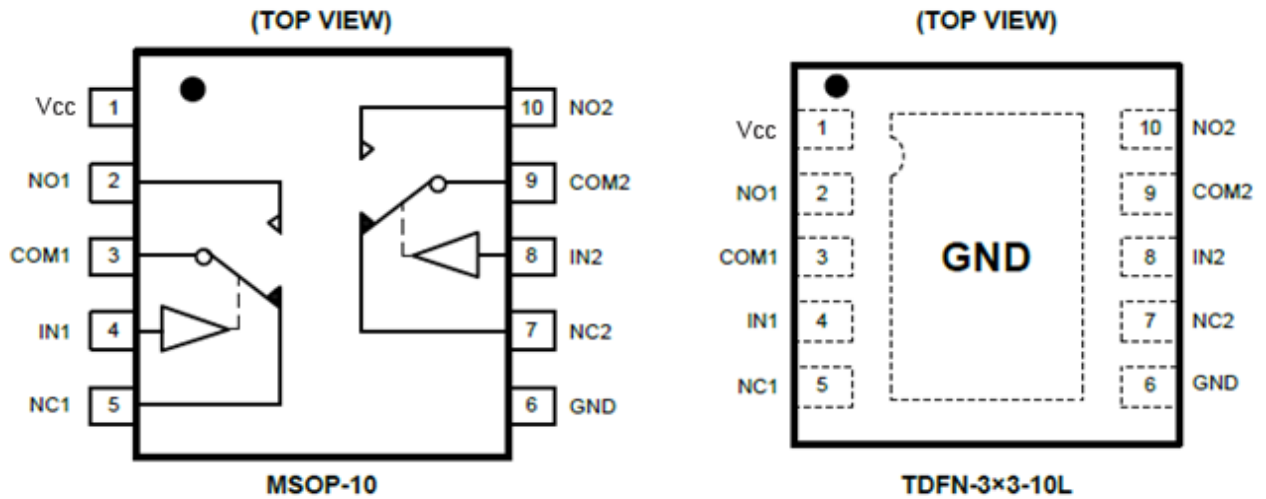

PIN DESCRIPTION

PIN	NAME	FUNCTION
1	Vcc	Power Supply.
2	NO1	Normally-Open Terminal.
3	COM1	Common Terminal.
4	IN1	Digital Control Pin.
5	NC1	Normally-Closed Terminal.
6	GND	Ground.
7	NC2	Normally-Closed Terminal.
8	IN2	Digital Control Pin.
9	COM2	Common Terminal.
10	NO2	Normally-Open Terminal.

Truth Table

LOGIC	NC1, NC2	NO1, NO2
0	ON	OFF
1	OFF	ON

LOGIC DIAGRAM

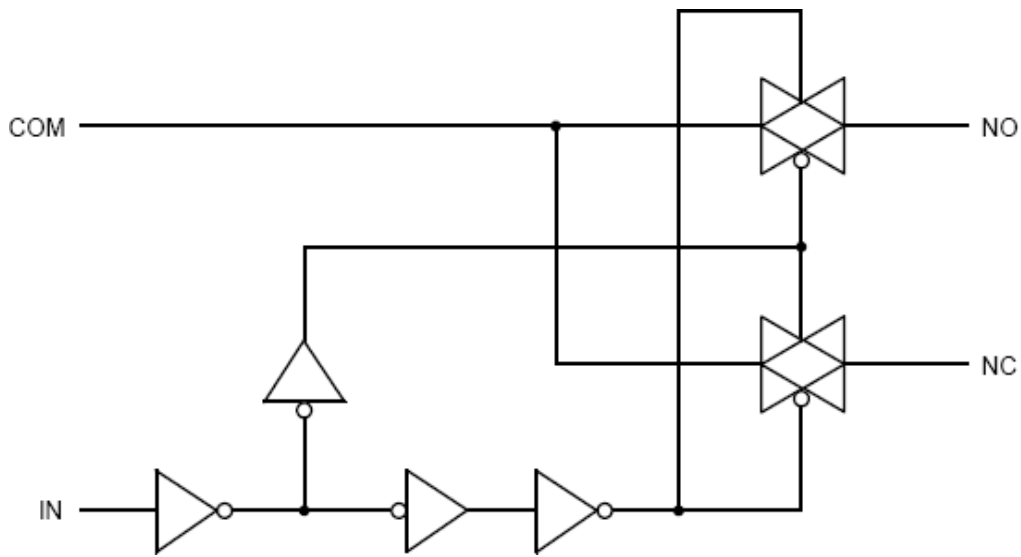

Figure 1. Logic equivalent circuit



BCT4005

Ultra Low ON-Resistance, Low Voltage, Dual, SPDT Analog Switch

ABSOLUTE MAXIMUM RATINGS

VCC, IN1, IN2 to GND.....	-0.5V to +5.25V
All Other Pins to GND.....	-0.5V to (V _{CC} + 0.5V)
Continuous Current (COM to NC/NO).....	±300mA
Peak Current (COM to NC/NO)(pulsed at 1ms, 10% duty cycle).....	±500mA
Operating Temperature Range	-40°C to +85°C
Storage Temperature Range.....	-65°C to +150°C
Junction Temperature.....	+150°C
Lead Temperature (soldering, 10s).....	+260°C

Stresses beyond those listed under “Absolute Maximum Ratings” may cause permanent damage to the device. These are stress ratings only, and functional operation of the device at these or any other conditions beyond those indicated in the operational sections of the specifications is not implied. Exposure to absolute maximum rating conditions for extended periods may affect device reliability.

CAUTION

This integrated circuit can be damaged by ESD if you don't pay attention to ESD protection. Broadchip recommends that all integrated circuits be handled with appropriate precautions. Failure to observe proper handling and installation procedures can cause damage. ESD damage can range from subtle performance degradation to complete device failure. Precision integrated circuits may be more susceptible to damage because very small parametric changes could cause the device not to meet its published specifications.

Broadchip reserves the right to make any change in circuit design, specification or other related things if necessary without notice at any time. Please contact Broadchip sales office to get the latest datasheet.



BCT4005

Ultra Low ON-Resistance, Low Voltage, Dual, SPDT Analog Switch

ELECTRICAL CHARACTERISTICS

(V_{cc} = +4.2V, GND = 0V, V_{IH} = +1.6V, V_{IL} = +0.6V, T_A = - 40°C to + 85°C. Typical values are at V_{cc} = +4.2V, T_A = +25°C, unless otherwise noted.)

PARAMETER	SYMBOL	CONDITIONS	TEMP	MIN	TPY	MAX	UNITS
ANALOG SWITCH							
Analog Signal Range	V _{NO} , V _{NC} , V _{COM}		- 40°C to +85°C	0		V _{CC}	V
On-Resistance	R _{ON}	V _{cc} = 4.2 V, V _{NO} , V _{NC} or V _{COM} = 1 V, I _{COM} = -100 mA, Test Circuit 1	+25°C		0.4	0.65	Ω
			- 40°C to +85°C			0.75	Ω
On-Resistance Match Between Channels	ΔR _{ON}	V _{cc} = 4.2 V, V _{NO} , V _{NC} or V _{COM} = 1 V, I _{COM} = -100 mA, Test Circuit 1	+25°C		0.04	0.15	Ω
			- 40°C to +85°C			0.2	Ω
On-Resistance Flatness	R _{FLAT(ON)}	V _{cc} = 4.2 V, V _{NO} , V _{NC} or V _{COM} = 1 V, I _{COM} = -100 mA, Test Circuit 1	+25°C		0.08	0.12	Ω
			- 40°C to +85°C			0.2	Ω
Source OFF Leakage current	I _{NC(OFF)} , I _{NO(OFF)}	V _{cc} = 4.2 V, V _{NO} or V _{NC} = 3.3 V/ 0.3 V, V _{COM} = 0.3 V/ 3.3 V	- 40°C to +85°C			1	μA
Channel ON Leakage current	I _{NC(ON)} , I _{NO(ON)} , I _{COM(ON)}	V _{cc} = 4.2 V, V _{COM} = 0.3 V/ 3.3 V, V _{NO} or V _{NC} = 0.3 V/ 3.3 V, or floating	- 40°C to +85°C			1	μA
DIGITAL INPUTS							
Input High Voltage	V _{INH}		- 40°C to +85°C	1.6			V
Input Low Voltage	V _{INL}		- 40°C to +85°C			0.5	V
Input Leakage Current	I _{IN}	V _{cc} = 4.2 V, V _{IN} = 0 V or 4.2 V	- 40°C to +85°C			1	μA
POWER REQUIREMENTS							
Power Supply Range	V _{CC}		- 40°C to +85°C	1.65		5.0	V
Power Supply Current	I _Q	V _{CC} = 4.2 V, V _{IN} = 0 V or V _{cc}	- 40°C to +85°C			1	μA



BCT4005

Ultra Low ON-Resistance, Low Voltage, Dual, SPDT Analog Switch

PARAMETER	SYMBOL	CONDITIONS	TEMP	MIN	TPY	MAX	UNITS
DYNAMIC CHARACTERISTICS							
Turn-On Time	t_{ON}	$V_{IN} = 2.1\text{ V to } 0\text{ V}$, $R_L = 50\ \Omega$, $C_L = 35\text{ pF}$, V_{NO1} or $V_{NC1} = V_{NO2}$ or $V_{NC2} = 2.1\text{V}$, Test Circuit2	+25°C		10		ns
Turn-Off Time	t_{OFF}	$V_{IN} = 2.1\text{ V to } 0\text{ V}$, $R_L = 50\ \Omega$, $C_L = 35\text{ pF}$, V_{NO1} or $V_{NC1} = V_{NO2}$ or $V_{NC2} = 2.1\text{V}$, Test Circuit2	+25°C		7.0		ns
Break-Before-Make Time Delay	t_d	$V_{IN} = 2.1\text{ V to } 0\text{ V}$, $R_L = 50\ \Omega$, $C_L = 35\text{ pF}$, V_{NO1} or $V_{NC1} = V_{NO2}$ or $V_{NC2} = 2.1\text{V}$, Test Circuit3	+25°C		6.0		ns
Off Isolation	O_{ISO}	$V_{BIAS} = 2.1\text{ V}$, $V_{IN} = 0\text{ dBm}$, Test Circuit4	100KHz	+25°C	-78		dB
			1MHz	+25°C	-58		dB
Channel-to-Channel Crosstalk	X_{TALK}	$V_{BIAS} = 2.1\text{ V}$, $V_{IN} = 0\text{ dBm}$, Test Circuit5	+25°C		-103		dB
Bandwidth -3 dB	BW	$V_{BIAS} = 2.1\text{ V}$, $V_{IN} = 0\text{ dBm}$, Test Circuit6	+25°C		70		MHz
Charge Injection Select Input to Common I/O	Q	V_{NO1} or $V_{NC1} = V_{NO2}$ or $V_{NC2} = 0\text{ V}$, $C_L = 1.0\text{ nF}$, Test Circuit7	+25°C		4.0		pC
Channel ON Capacitance	C_{ON}		+25°C		106		pF



BCT4005

Ultra Low ON-Resistance, Low Voltage, Dual, SPDT Analog Switch

ELECTRICAL CHARACTERISTICS

(V_{CC} = +2.7V to +3.6V, GND = 0V, V_{IH} = +1.6V, V_{IL} = +0.4V, T_A = - 40°C to + 85°C. Typical values are at V_{CC} = +3.0V, T_A = + 25°C, unless otherwise noted.)

PARAMETER	SYMBOL	CONDITIONS	TEMP	MIN	TPY	MAX	UNITS
ANALOG SWITCH							
Analog Signal Range	V _{NO} , V _{NC} , V _{COM}		- 40°C to +85°C	0		V _{CC}	V
On-Resistance	R _{ON}	V _{CC} = 2.7 V, V _{NO} , V _{NC} or V _{COM} = 1 V, I _{COM} = -100 mA, Test Circuit 1	+25°C		0.5	0.7	Ω
			- 40°C to +85°C			0.8	Ω
On-Resistance Match Between Channels	ΔR _{ON}	V _{CC} = 2.7 V, V _{NO} , V _{NC} or V _{COM} = 1 V, I _{COM} = -100 mA, Test Circuit 1	+25°C		0.03	0.15	Ω
			- 40°C to +85°C			0.2	Ω
On-Resistance Flatness	R _{FLAT(ON)}	V _{CC} = 2.7 V, V _{NO} , V _{NC} or V _{COM} = 1 V, I _{COM} = -100 mA, Test Circuit 1	+25°C		0.1	0.18	Ω
			- 40°C to +85°C			0.2	Ω
Source OFF Leakage current	I _{NC(OFF)} , I _{NO(OFF)}	V _{CC} = 3.6 V, V _{NO} or V _{NC} = 3.3 V / 0.3 V, V _{COM} = 0.3 V/ 3.3 V	- 40°C to +85°C			1	μA
Channel ON Leakage current	I _{NC(ON)} , I _{NO(ON)} , I _{COM(ON)}	V _{CC} = 3.6 V, V _{COM} = 0.3 V/ 3.3 V, V _{NO} or V _{NC} = 0.3 V/ 3.3 V, or floating	- 40°C to +85°C			1	μA
DIGITAL INPUTS							
Input High Voltage	V _{INH}		- 40°C to +85°C	1.5			V
Input Low Voltage	V _{INL}		- 40°C to +85°C			0.4	V
Input Leakage Current	I _{IN}	V _{CC} = 2.7 V, V _{IN} = 0 V or 2.7 V	- 40°C to +85°C			1	μA



BCT4005

Ultra Low ON-Resistance, Low Voltage, Dual, SPDT Analog Switch

PARAMETER	SYMBOL	CONDITIONS	TEMP	MIN	TPY	MAX	UNITS
DYNAMIC CHARACTERISTICS							
Turn-On Time	t_{ON}	$V_{IN} = 1.5\text{ V to } 0\text{ V}$, $R_L = 50\ \Omega$, $C_L = 35\text{ pF}$, $V_{NO1}\text{ OR } V_{NC1} = V_{NO2}\text{ OR } V_{NC2} = 1.5\text{ V}$, Test Circuit2	+25°C		15		ns
Turn-Off Time	t_{OFF}	$V_{IN} = 1.5\text{ V to } 0\text{ V}$, $R_L = 50\ \Omega$, $C_L = 35\text{ pF}$, $V_{NO1}\text{ OR } V_{NC1} = V_{NO2}\text{ OR } V_{NC2} = 1.5\text{ V}$, Test Circuit2	+25°C		15		ns
Break-Before-Make Time Delay	t_d	$V_{IN} = 1.5\text{ V to } 0\text{ V}$, $R_L = 50\ \Omega$, $C_L = 35\text{ pF}$, $V_{NO1}\text{ OR } V_{NC1} = V_{NO2}\text{ OR } V_{NC2} = 1.5\text{ V}$, Test Circuit3	+25°C		9.2		ns
Off Isolation	O_{ISO}	$V_{BIAS} = 2.1\text{ V}$, $V_{IN} = 0\text{ dBm}$, Test Circuit4	100KHz	+25°C		-78	dB
			1MHz	+25°C		-58	dB
Channel-to-Channel Crosstalk	XTALK	$V_{BIAS} = 2.1\text{ V}$, $V_{IN} = 0\text{ dBm}$, Test Circuit5	100KHz	+25°C		-103	dB
			1MHz	+25°C		-90	dB
Bandwidth -3 dB	BW	$V_{BIAS} = 2.1\text{ V}$, $V_{IN} = 0\text{ dBm}$, Test Circuit6	+25°C		70		MHz
Charge Injection Select Input to Common I/O	Q	$V_{NO1}\text{ OR } V_{NC1} = V_{NO2}\text{ OR } V_{NC2} = 0\text{ V}$, $C_L = 1.0\text{ nF}$ Test Circuit7	+25°C		3.0		pC
Channel ON Capacitance	CON		+25°C		106		pF

Test Diagram

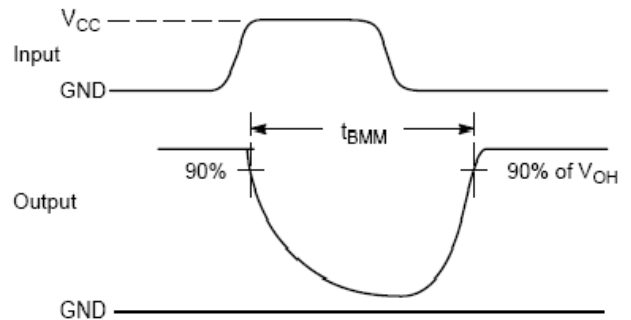
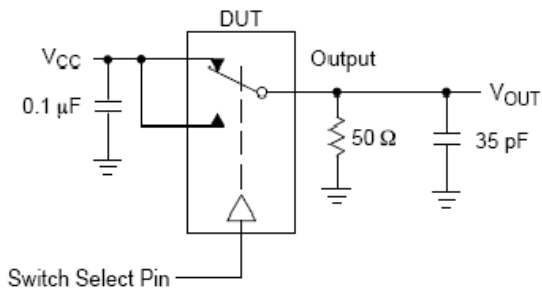

Figure 2. t_{BMM} (Time Break-Before-Make)

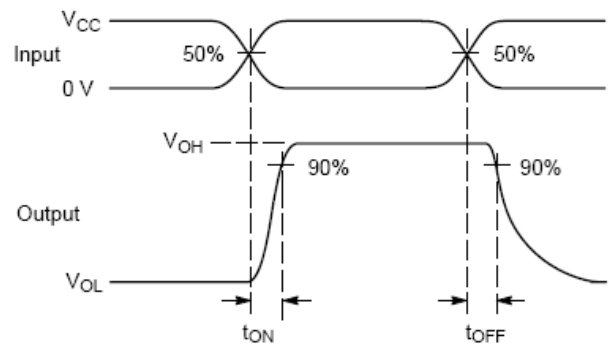
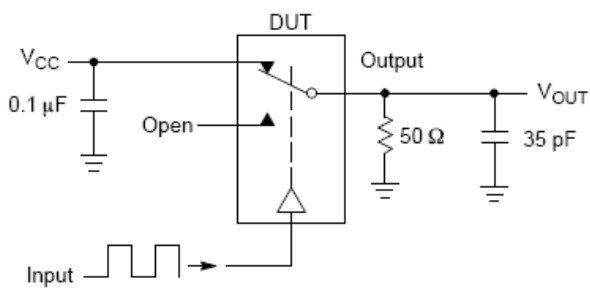

Figure 3. t_{ON/OFF}

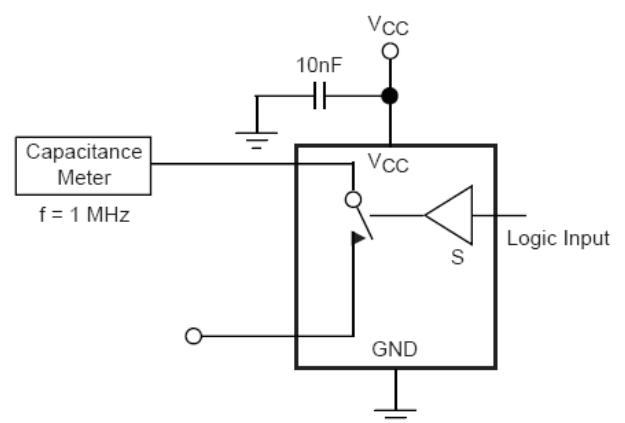
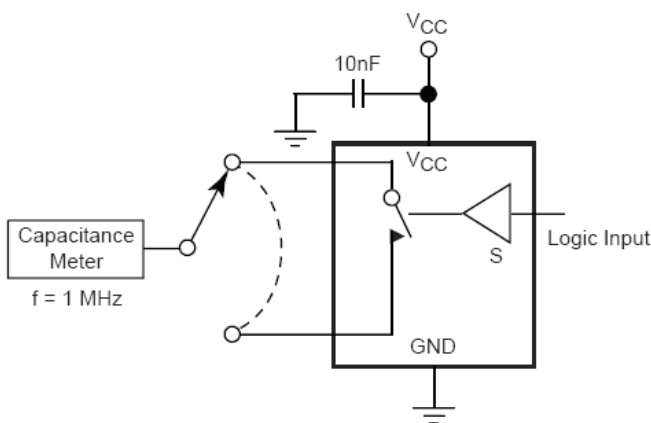

Figure 3. Channel ON/OFF Capacitance

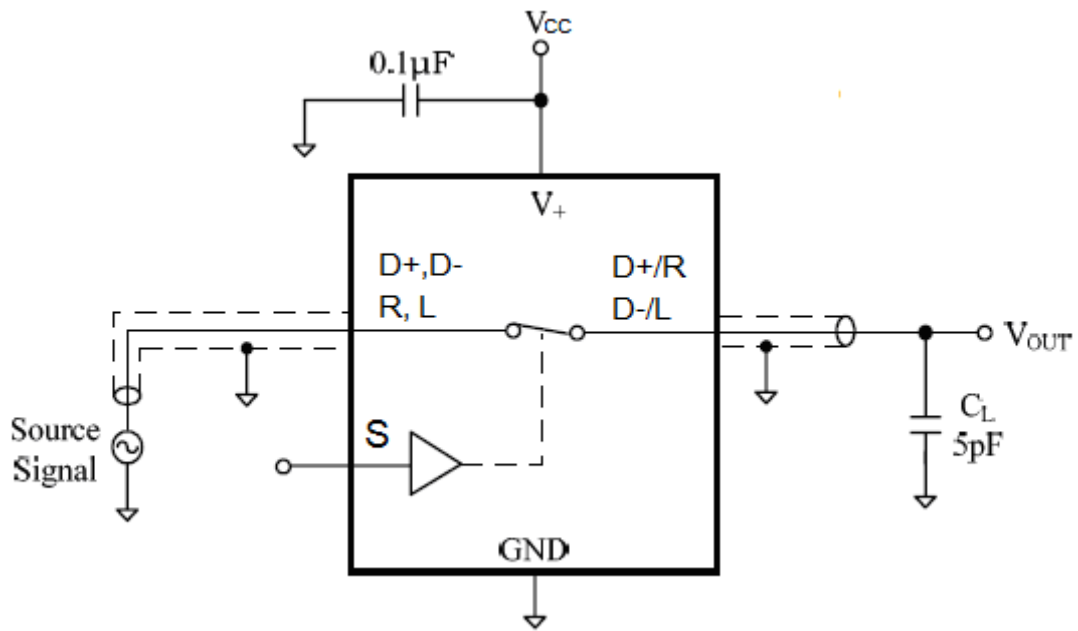
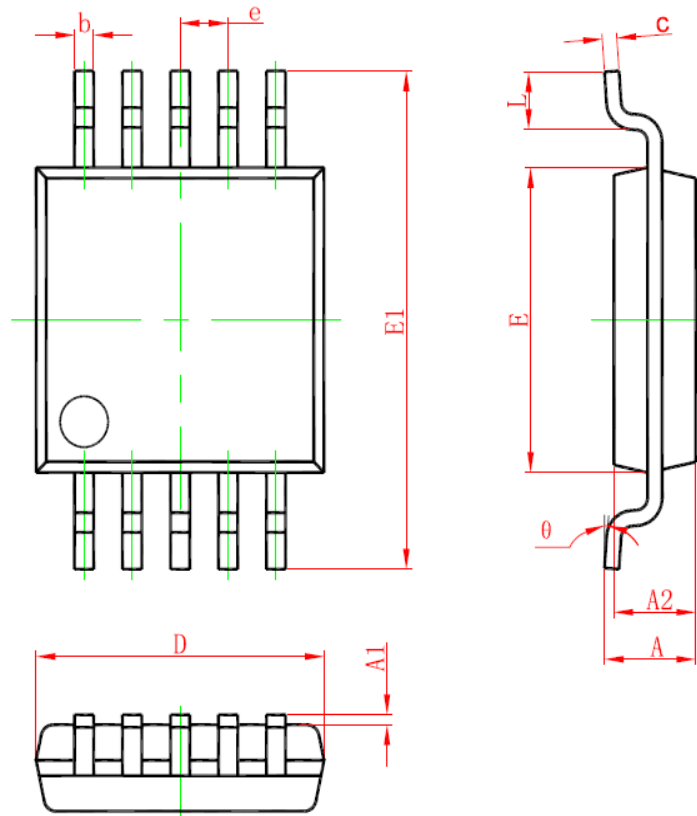

Figure 4. Bandwidth -3dB

PACKAGE OUTLINE DIMENSIONS

MSOP-10



Symbol	Dimensions In Millimeters		Dimensions In Inches	
	Min	Max	Min	Max
A	0.820	1.100	0.032	0.043
A1	0.020	0.150	0.001	0.006
A2	0.750	0.950	0.030	0.037
b	0.180	0.280	0.007	0.011
c	0.090	0.230	0.004	0.009
D	2.900	3.100	0.114	0.122
e	0.50(BSC)		0.020(BSC)	
E	2.900	3.100	0.114	0.122
E1	4.750	5.050	0.187	0.199
L	0.400	0.800	0.016	0.031
θ	0°	6°	0°	6°

PACKAGE OUTLINE DIMENSIONS

QFN3*3-10L

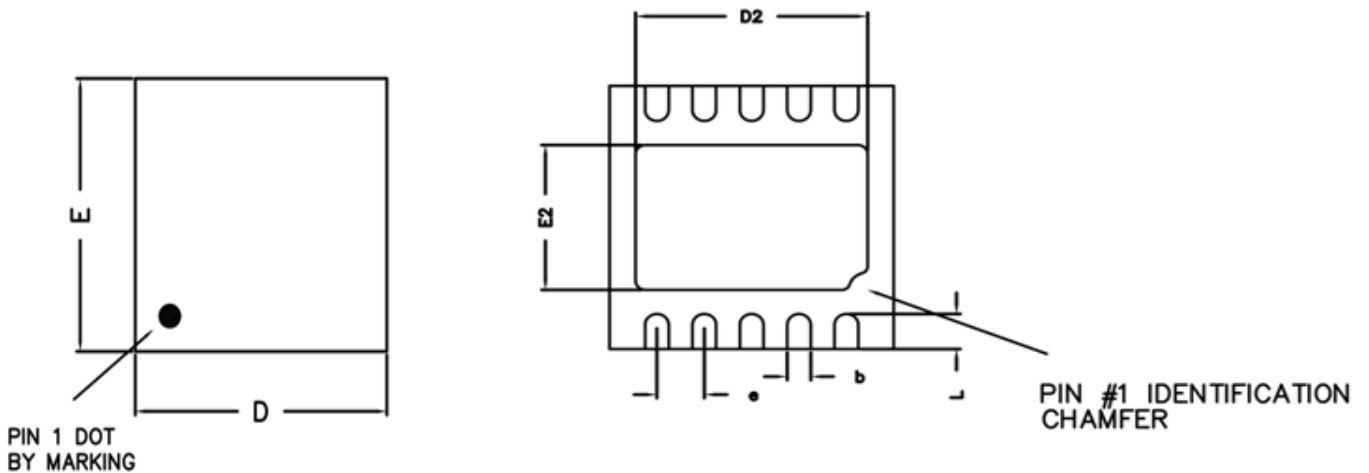

BOTTOM VIEW

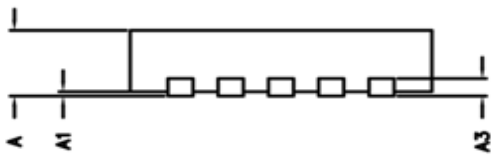

SIDE VIEW

COMMON DIMENSIONS(MM)			
PKG.	w: VERY VERY THIN		
REF.	MIN.	NOM.	MAX
A	0.70	0.75	0.80
A1	0.00	-	0.05
A3	0.2 REF.		
D	2.95	3.00	3.05
E	2.95	3.00	3.05
b	0.18	0.23	0.28
L	0.30	0.40	0.50
D2	2.30	2.45	2.55
E2	1.50	1.65	1.75
e	0.50 BSC		

X-ON Electronics

Largest Supplier of Electrical and Electronic Components

Click to view similar products for [Analogue Switch ICs](#) category:

Click to view products by [BROADCHIP](#) manufacturer:

Other Similar products are found below :

[FSA3051TMX](#) [NLAS4684FCTCG](#) [NLAS5223BLMNR2G](#) [NLVAS4599DTT1G](#) [NLX2G66DMUTCG](#) [425541DB](#) [425528R](#) [099044FB](#)
[MAX4762ETB+](#) [NLAS5123MNR2G](#) [PI5A4157CEX](#) [PI5A4599BCEX](#) [NLAS4717EPFCT1G](#) [PI5A3167CCEX](#) [SLAS3158MNR2G](#)
[PI5A392AQEX](#) [PI5A392AQE](#) [FSA634UCX](#) [NX3L1T5157GMZ](#) [ADG714BCPZ-REEL7](#) [HT4051ARZ](#) [TC4066BP\(N,F\)](#) [DG302BDJ-E3](#)
[ADG854BCPZ-REEL7](#) [PI5A100WE](#) [PI5A100QEX](#) [HV2733FG-G](#) [HV2701FG-G](#) [HV2301FG-G](#) [HV2301FG-G-M931](#) [RS2117YUTQK10](#)
[RS2118YUTQK10](#) [RS2227XUTQK10](#) [ADG452BRZ-REEL7](#) [MAX391CPE+](#) [MAX4744ELB+](#) [MAX4730EXT+T](#) [MAX4730ELT+](#)
[MAX333AEWP+](#) [BU4066BC](#) [MAX313CPE+](#) [BU4S66G2-TR](#) [NLASB3157MTR2G](#) [NX3L4684TK,115](#) [NX5L2750CGUX](#)
[NLAS4157DFT2G](#) [NLAS4599DFT2G](#) [NLASB3157DFT2G](#) [NLAST4599DFT2G](#) [NLAST4599DTT1G](#)