

BCT4222B

High-Speed DPDT Analog Switch

Features

- ◆ V_{CC} Operating Range: 1.65V to 4.5V
- ◆ Rail-to-Rail Signal Range
- ◆ ON-Resistance Matching: 0.05 Ω (TYP)
- ◆ ON-Resistance Flatness: 0.08Ω (TYP)
- ◆ High Off Isolation: 57dB at 10MHz
- ◆ 54dB (10MHz) Crosstalk Rejection Reduces Signal Distortion
- ◆ Break-Before-Make Switching
- ◆ -3dB Bandwidth: 350MHz
- ◆ Extended Industrial Temperature Range: -40°C to 85°C
- ◆ Improved Direct Replacement for NLAS7222
- ◆ Packaging (Pb-free & Green available)

Applications

- Cell
- Phones
- PDA's
- Portable Instrumentation
- Differential Signal Data Routings
- USB 2.0 Signal Routing

General Description

The BCT4222B is a high bandwidth, fast double-pole double-throw (DPDT) analog switch. Its wide bandwidth and low bit-to-bit skew allow it to pass high-speed differential signals with good signal integrity. Each switch is bidirectional and offers little or no attenuation of the high-speed signals at the outputs. Industry-leading advantages include a propagation delay of less than 250ps, resulting from its low channel resistance and low I/O capacitance. Its high channel-to-channel crosstalk rejection results in minimal noise interference.

Connection Diagram

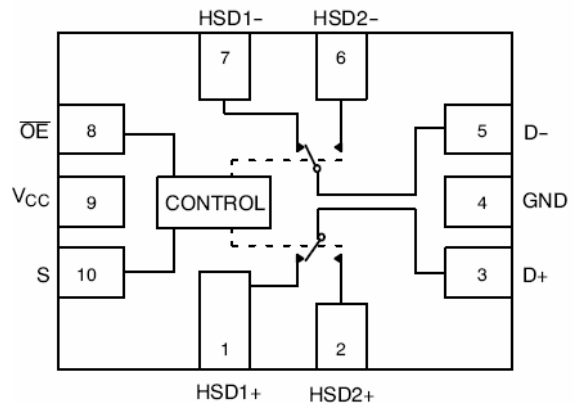

Figure 1. Pin Connections and Logic Diagram (BCT4222B Top View)



BCT4222B High-Speed DPDT Analog Switch

Pin Description

Pin Number	Name	Description
10	S	Select Input
4	GND	Ground
1, 2	HSD1+,HSD2+	Data Ports
7, 6	HSD1-,HSD2-	Data Ports
3, 5	D+, D-	Data Ports
9	VCC	Positive Power Supply
8	/OE	Output Enable

Logic Function Table

/OE	S	HSD1+,HSD1-	HSD2+,HSD2-
1	X	OFF	OFF
0	0	ON	OFF
0	1	OFF	ON

ORDERING INFORMATION

Ordering Code	Package Description	Temp Range	Top Marking
BCT4222BETB-TR	10-pin WQFN 1.4X1.8	-40°C to +85°C	AJX



BCT4222B High-Speed DPDT Analog Switch

MAXIMUM RATINGS

Symbol	Pins	Parameter	Value	Unit
V_{CC}	V_{CC}	Positive DC Supply Voltage	-0.5 to +4.6	V
V_{IS}	HSD1+, HSD1-, HSD2+, HSD2-	Analog Signal Voltage	-0.5 to $V_{CC} + 0.3$	V
	D+, D-		-0.5 to +4.6	
V_{IN}	/OE, S	Control Input Voltage	-0.5 to +4.6	V
I_{CC}	V_{CC}	Positive DC Supply Current	50	mA
T_S		Storage Temperature	-65 to +150	°C
I_{IN}	/OE, S	Control Input Current	± 20 mA	mA

Stresses beyond those listed under “Absolute Maximum Ratings” may cause permanent damage to the device. These are stress ratings only, and functional operation of the device at these or any other conditions beyond those indicated in the operational sections of the specifications is not implied. Exposure to absolute maximum rating conditions for extended periods may affect device reliability

ESD PROTECTION

Symbol	Parameter	Value	Unit
ESD	Human Body Model - All Pins	2.0	kV
ESD	Human Body Model - I/O to GND	8.0	kV



BCT4222B High-Speed DPDT Analog Switch

RECOMMENDED OPERATING CONDITIONS

Symbol	Pins	Parameter	Min	Max	Unit
V _{CC}		Positive DC Supply Voltage	1.65	4.5	V
V _{IS}	HSD1+, HSD1-, HSD2+, HSD2-	Analog Signal Voltage	GND	V _{CC}	V
	D+, D-		GND	4.5	
V _{IN}	/OE, S	Digital Select Input Voltage	GND	V _{CC}	V
T _A		Operating Temperature Range	-40	+85	°C

Minimum and maximum values are guaranteed through test or design across the Recommended Operating Conditions, where applicable. Typical values are listed for guidance only and are based on the particular conditions listed for section, where applicable. These conditions are valid for all values found in the characteristics tables unless otherwise specified in the test conditions.

DC ELECTRICAL CHARACTERISTICS (Typical: T = 25°C)

BCT4222B SUPPLY AND LEAKAGE CURRENT

Symbol	Pins	Parameter	Test Conditions	V _{CC} (V)	-40°C to +85°C			Unit
					Min	Typ	Max	
I _{CC}	V _{CC}	Quiescent Supply Current	V _{IS} = V _{CC} or GND; I _{OUT} = 0 A	1.65 - 4.5	-	-	1.0	uA
I _{CCT}	V _{CC}	Increase in I _{CC} per Control Voltage	V _{IN} = 2.6 V	3.6	-	-	10	uA
I _{oz}	HSD1+, HSD1-, HSD2+, HSD2-	OFF State Leakage Current	0 ≤ V _{IS} ≤ V _{CC}	1.65 - 4.5	-	-	±1.0	uA
I _{OFF}	D+, D-	Power OFF Leakage Current	0 ≤ V _{IS} ≤ 4.5 V	0	-	-	±1.0	uA

BCT4222B DIGITAL INPUT VOLTAGE

Symbol	Pins	Parameter	Test Conditions	V _{CC} (V)	-40°C to +85°C			Unit
					Min	Typ	Max	
V _{IH}	S,/OE	Input High Voltage		3.6	1.6	-	-	V
V _{IL}	S,/OE	Input Low Voltage		3.6	-	-	0.5	V
I _{IN}	S,/OE	Input current	S,/OE = 0V or V _{CC}		-	-	±1.0	uA

BCT4222B HIGH SPEED ON RESISTANCE

Symbol	Pins	Parameter	Test Conditions	V _{CC} (V)	-40°C to +85°C			Unit
					Min	Typ	Max	
R _{ON}		On-Resistance	V _{IS} = 0 V to 0.4 V, I _{ON} = 8 mA	2.7		9.0	12	Ω
				3.3		8.0	10	
				4.5		7.0	8.0	
R _{FLAT}		On-Resistance	V _{IS} = 0 V to 0.4 V, I _{ON} = 8 mA	2.7		1.6	Ω	
				3.3		1.5		
		4.5		1.4				
R _{ON}		On-Resistance	V _{IS} = 0 V to 0.4 V, I _{ON} = 8 mA	2.7		1.6	Ω	
				3.3		1.5		
		4.5		1.4				
		Matching						

BCT4222B DC ELECTRICAL CHARACTERISTICS

(continued) FULL SPEED ON RESISTANCE (Typical: T = 25°C, V_{CC} = 3.3 V)

Symbol	Pins	Parameter	Test Conditions	V _{CC} (V)	-40°C to +85°C			Unit
					Min	Typ	Max	
R _{ON}		On-Resistance	V _{IS} = 0 V to V _{CC} , I _{ON} = 8 mA	2.7		9.0	12	Ω
				3.3		8.5	10.5	
				4.5		7.5	8.5	
R _{FLAT}		On-Resistance	V _{IS} = 0 V to V _{CC} , I _{ON} = 8 mA	2.7		1.6	Ω	
				3.3		1.5		
		4.5		1.4				
R _{ON}		On-Resistance	V _{IS} = 0 V to V _{CC} , I _{ON} = 8 mA	2.7		2.20	Ω	
				3.3		2.45		
		4.5		2.65				
		Matching						



BCT4222B High-Speed DPDT Analog Switch

BCT4222B AC ELECTRICAL CHARACTERISTICS

TIMING/FREQUENCY (Typical: T = 25°C, V_{CC} = 3.3 V, R_L = 50Ω, C_L = 5 pF, f = 1 MHz)

Symbol	Pins	Parameter	Test Conditions	V _{CC} (V)	-40°C to +85°C			Unit
					Min	Typ	Max	
t _{ON}	Closed to Open	Turn-ON Time	See test circuit 2	1.65 - 4.5		14	30	ns
t _{OFF}	Open to Closed	Turn-OFF Time	See test circuit 2	1.65 - 4.5		10	20	ns
t _{BBM}		Break-Before-Make Delay	See test circuit 1	1.65 - 4.5	3.0	4.4	7.0	ns
BW		-3 dB Bandwidth	C _L = 5 pF	1.65 - 4.5		300		MHz
			C _L = 0 pF			350		

BCT4222B ISOLATION

(Typical: T = 25°C, V_{CC} = 3.3 V, R_L = 50Ω, C_L = 5 pF, f = 1 MHz)

Symbol	Pins	Parameter	Test Conditions	V _{CC} (V)	-40°C to +85°C			Unit
					Min	Typ	Max	
OIRR	Open	OFF-Isolation	f = 250 MHz	1.65 - 4.5		-22		dB
XTALK	HSD1+ to HSD1-	Non-Adjacent Channel Crosstalk	f = 250 MHz	1.65 - 4.5		-30		dB

BCT4222B CAPACITANCE

(Typical: $T = 25^{\circ}\text{C}$, $V_{CC} = 3.3\text{ V}$, $R_L = 50\ \Omega$, $C_L = 5\text{ pF}$, $f = 1\text{ MHz}$)

Symbol	Pins	Parameter	Test Conditions	-40°C to +85°C			Unit
				Min	Typ	Max	
C_{IN}	OE	Control Pin Input Capacitance	$V_{CC} = 0\text{ V}$	-	3.0	-	pF
C_{ON}	D+ to HSD1+ or HSD2+	ON Capacitance	$V_{CC} = 3.3\text{ V}$; $OE = 0\text{ V}$	-	8.0	-	pF
C_{OFF}	HSD2+, HSD2-	OFF Capacitance	$V_{CC} = V_{IS} = 3.3\text{ V}$; $OE = 3.3\text{ V}$	-	4.5	-	pF

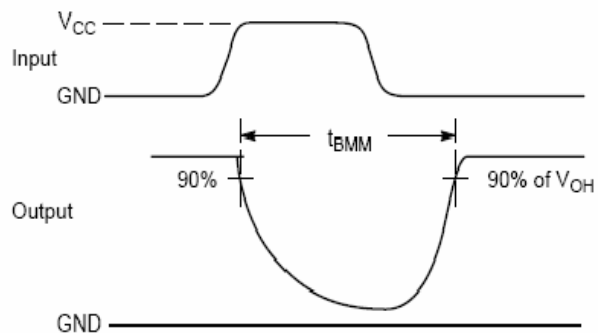
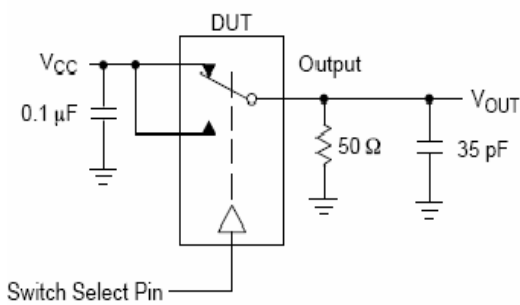

Figure 1. t_{BMM} (Time Break-Before-Make)

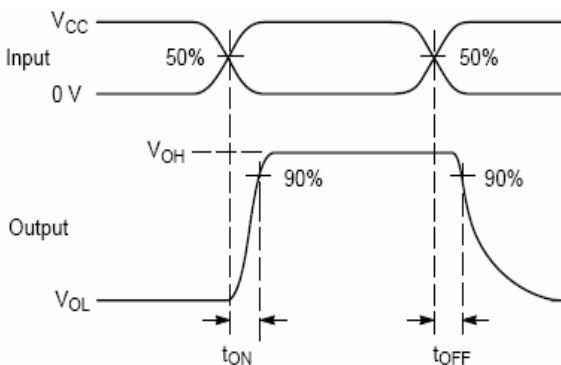
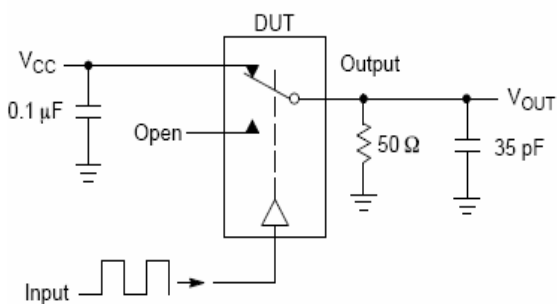

Figure 2. t_{ON} / t_{OFF}

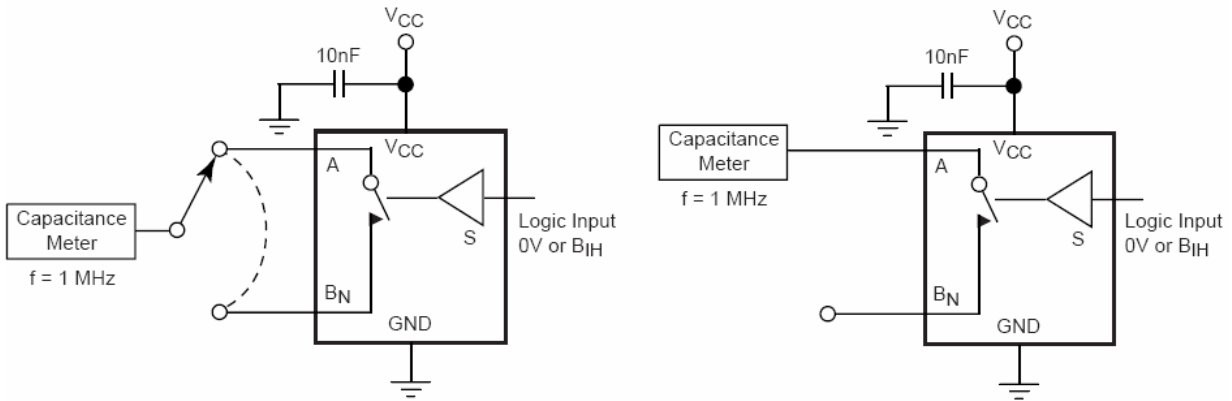

Figure 3. Channel ON/OFF Capacitance

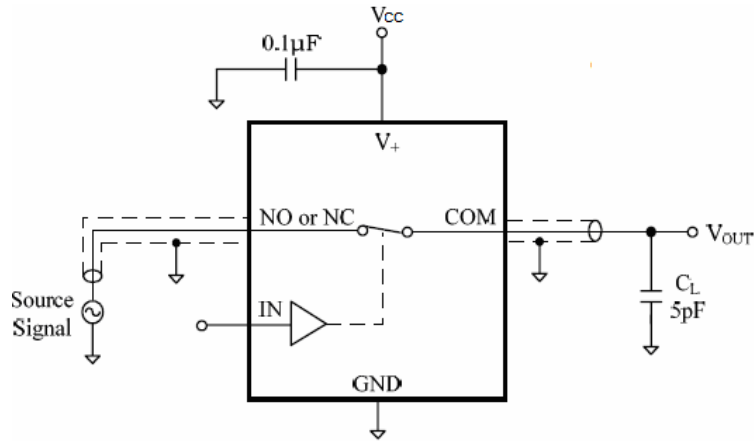

Figure 4. Bandwidth -3dB

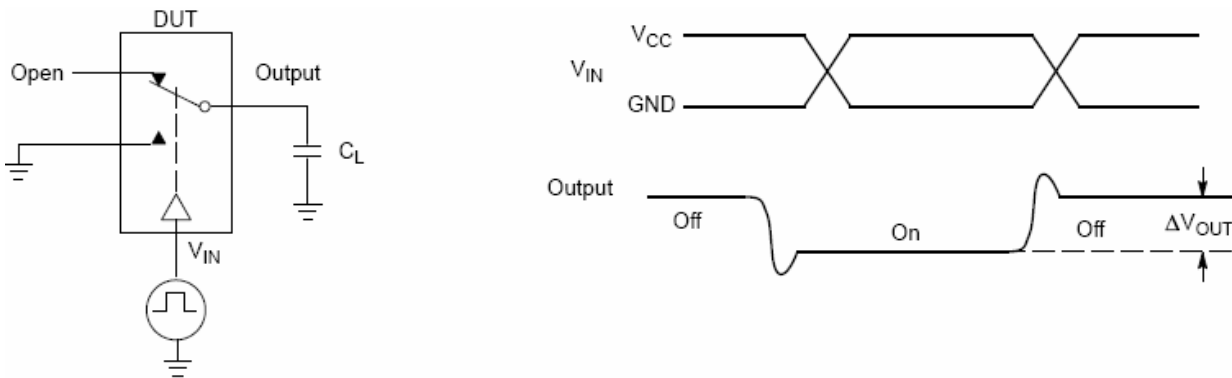

Figure 5. Charge Injecting (Q)

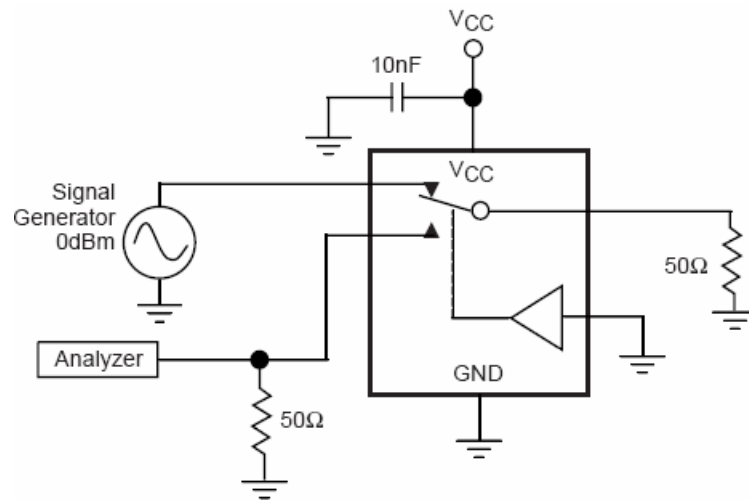

Figure 6. Crosstalk

Applications Information

Logic Inputs

The logic control inputs can be driven up to +3.6V regardless of the supply voltage. For example, given a +3.3V supply, the output enables or select pins may be driven low to 0V and high to 3.6V.

Package Information

PIN 1 DOT
BY MARKING

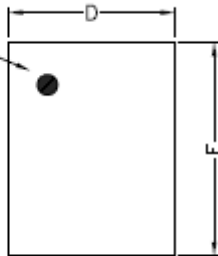

TOP VIEW

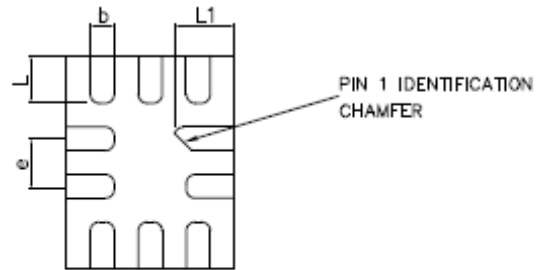

BOTTOM VIEW

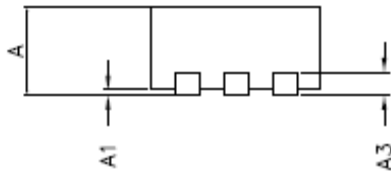

COMMON DIMENSIONS(MM)			
PKG.	UT: ULTRA THIN		
REF.	MIN.	NOM.	MAX
A	0.50	0.55	0.60
A1	0.00	—	0.05
A3	0.15 REF.		
D	1.35	1.40	1.45
E	1.75	1.80	1.85
b	0.15	0.20	0.25
L	0.30	0.40	0.50
L1	0.40	0.50	0.60
e	0.40 BSC		

X-ON Electronics

Largest Supplier of Electrical and Electronic Components

Click to view similar products for [Analogue Switch ICs](#) category:

Click to view products by [BROADCHIP](#) manufacturer:

Other Similar products are found below :

[FSA3051TMX](#) [NLAS4684FCTCG](#) [NLAS5223BLMNR2G](#) [NLVAS4599DTT1G](#) [NLX2G66DMUTCG](#) [425541DB](#) [425528R](#) [099044FB](#)
[MAX4762ETB+](#) [NLAS5123MNR2G](#) [PI5A4157CEX](#) [PI5A4599BCEX](#) [NLAS4717EPFCT1G](#) [PI5A3167CCEX](#) [SLAS3158MNR2G](#)
[PI5A392AQEX](#) [PI5A392AQE](#) [FSA634UCX](#) [NX3L1T5157GMZ](#) [ADG714BCPZ-REEL7](#) [HT4051ARZ](#) [TC4066BP\(N,F\)](#) [DG302BDJ-E3](#)
[ADG854BCPZ-REEL7](#) [PI5A100WE](#) [PI5A100QEX](#) [HV2733FG-G](#) [HV2701FG-G](#) [HV2301FG-G](#) [HV2301FG-G-M931](#) [RS2117YUTQK10](#)
[RS2118YUTQK10](#) [RS2227XUTQK10](#) [ADG452BRZ-REEL7](#) [MAX391CPE+](#) [MAX4744ELB+](#) [MAX4730EXT+T](#) [MAX4730ELT+](#)
[MAX333AEWP+](#) [BU4066BC](#) [MAX313CPE+](#) [BU4S66G2-TR](#) [NLASB3157MTR2G](#) [NX3L4684TK,115](#) [NX5L2750CGUX](#)
[NLAS4157DFT2G](#) [NLAS4599DFT2G](#) [NLASB3157DFT2G](#) [NLAST4599DFT2G](#) [NLAST4599DTT1G](#)