



BCT4227 High-Speed DPDT Analog Switch

BCT4227

High-Speed DPDT Analog Switch

FEATURES

- ◆ V_{CC} Operating Range: 1.65V to 4.5V
- ◆ Rail-to-Rail Signal Range
- ◆ ON-Resistance Matching: 0.05 Ω (TYP)
- ◆ ON-Resistance Flatness: 0.08Ω (TYP)
- ◆ High Off Isolation: 58dB at 10MHz
- ◆ 54dB (10MHz) Crosstalk Rejection Reduces Signal Distortion
- ◆ Break-Before-Make Switching
- ◆ -3dB Bandwidth: 720MHz
- ◆ Extended Industrial Temperature Range: -40°C to 85°C
- ◆ Packaging (Pb-free & Green available)

APPLICATIONS

Cell Phones
PDAs
Portable Instrumentation
Differential Signal Data Routings
USB 2.0 Signal Routing

GENERAL DESCRIPTION

The BCT4227 is a high bandwidth, fast double-pole double-throw (DPDT) analog switch. Its wide bandwidth and low bit-to-bit skew allow it to pass high-speed differential signals with good signal integrity. Each switch is bidirectional and offers little or no attenuation of the high-speed signals at the outputs. Industry-leading advantages include a propagation delay of less than 250ps, resulting from its low channel resistance and low I/O capacitance. Its high channel-to-channel crosstalk rejection results in minimal noise interference.

ORDERING INFORMATION

Order Number	Package Type	Temperature Range	Marking	QTY/Reel
BCT4227ETB-TR	QFN1.8x1.4-10L	-40°C to +85°C	AMX	3000
BCT4227EMB-TR	MSOP10	-40°C to +85°C	4227 XXXXXX	4000

Note: "XXXXXX" in Marking will be appeared as the batch code.

PIN CONFIGURATION (Top View)

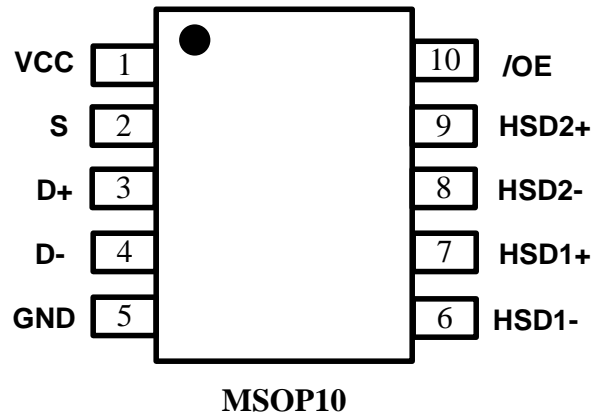
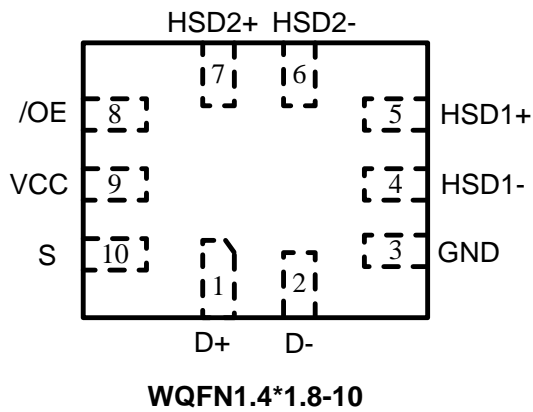

PIN DESCRIPTION

Pin Number	Name	Description
10	SEL	Select Input
3	GND	Ground
5, 4	HSD1+, HSD1-	Data Ports 1
7, 6	HSD2+,HSD2-	Data Ports 2
1, 2	D+, D-	Data Ports
9	VCC	Positive Power Supply
8	/OE	Output Enable

LOGIC FUNCTION TABLE

/OE	SEL	HSD1+,HSD1-	HSD2+,HSD2-
1	X	OFF	OFF
0	0	ON	OFF
0	1	OFF	ON

MAXIMUM RATINGS

Symbol	Pins	Parameter	Value	Unit
V_{CC}	V_{CC}	Positive DC Supply Voltage	-0.5 to +5.25	V
V_{IS}	HSD1+, HSD1-, HSD2+, HSD2-	Analog Signal Voltage	-0.5 to $V_{CC} + 0.3$	V
	D+, D-		-0.5 to +5.25	
V_{IN}	/OE	Control Input Voltage	-0.5 to +5.25	V
I_{CC}	V_{CC}	Positive DC Supply Current	50	mA
T_S		Storage Temperature	-65 to +150	°C
I_{IN}	/OE	Control Input Current	±20mA	mA

Stresses beyond those listed under “Absolute Maximum Ratings” may cause permanent damage to the device. These are stress ratings only, and functional operation of the device at these or any other conditions beyond those indicated in the operational sections of the specifications is not implied. Exposure to absolute maximum rating conditions for extended periods may affect device reliability

ESD PROTECTION

Symbol	Parameter	Value	Unit
ESD	Human Body Model - All Pins	4.0	kV
ESD	Human Body Model - I/O to GND	8.0	kV



BCT4227 High-Speed DPDT Analog Switch

RECOMMENDED OPERATING CONDITIONS

Symbol	Pins	Parameter	Min	Max	Unit
V_{CC}		Positive DC Supply Voltage	1.65	4.5	V
V_{IS}	HSD1+, HSD1-, HSD2+, HSD2-	Analog Signal Voltage	GND	V_{CC}	V
	D+, D-		GND	4.2	
V_{IN}	/OE	Digital Select Input Voltage	GND	V_{CC}	V
T_A		Operating Temperature Range	-40	+85	°C

Minimum and maximum values are guaranteed through test or design across the Recommended Operating Conditions, where applicable. Typical values are listed for guidance only and are based on the particular conditions listed for section, where applicable. These conditions are valid for all values found in the characteristics tables unless otherwise specified in the test conditions.

DC ELECTRICAL CHARACTERISTICS (Typical: T = 25°C)

BCT4227 SUPPLY AND LEAKAGE CURRENT

Symbol	Pins	Parameter	Test Conditions	V _{CC} (V)	-40°C to +85°C			Unit
					Min	Typ	Max	
I _{CC}	V _{CC}	Quiescent Supply Current	V _{IS} = V _{CC} or GND; I _{OUT} = 0 A	1.65 - 4.5	-	-	1.0	uA
I _{CCT}	V _{CC}	Increase in I _{CC} per Control Voltage	V _{IN} = 2.6 V	3.6	-	-	10	uA
I _{OZ}	HSD1+, HSD1-, HSD2+, HSD2-	OFF State Leakage Current	0 ≤ V _{IS} ≤ V _{CC}	1.65 - 4.5	-	-	±1.0	uA
I _{OFF}	D+, D-	Power OFF Leakage Current	0 ≤ V _{IS} ≤ 4.5 V	0	-	-	±1.0	uA

BCT4227 DIGITAL INPUT VOLTAGE

Symbol	Pins	Parameter	Test Conditions	V _{CC} (V)	-40°C to +85°C			Unit
					Min	Typ	Max	
V _{IH}	S,/OE	Input High Voltage		3.6	1.6	-	-	V
V _{IL}	S,/OE	Input Low Voltage		3.6	-	-	0.5	V

BCT4227 HIGH SPEED ON RESISTANCE

Symbol	Pins	Parameter	Test Conditions	V _{CC} (V)	-40°C to +85°C			Unit
					Min	Typ	Max	
R _{ON}		On-Resistance	V _{IS} = 0 V to 0.4 V, I _{ON} = 8 mA	2.7		9.0	12	Ω
				3.3		8.0	10	
				4.2		7.0	8.0	
R _{FLAT}		On-Resistance	V _{IS} = 0 V to 0.4 V, I _{ON} = 8 mA	2.7		1.6		Ω
				3.3		1.5		
		4.2		1.4				
R _{ON}		On-Resistance	V _{IS} = 0 V to 0.4 V, I _{ON} = 8 mA	2.7		1.6		Ω
				3.3		1.5		
		4.2		1.4				

BCT4227 DC ELECTRICAL CHARACTERISTICS

(continued) FULL SPEED ON RESISTANCE (Typical: T = 25°C, V_{CC} = 3.3 V)

Symbol	Pins	Parameter	Test Conditions	V _{CC} (V)	-40°C to +85°C			Unit
					Min	Typ	Max	
R _{ON}		On-Resistance	V _{IS} = 0 V to V _{CC} , I _{ON} = 8 mA	2.7		9.0	12	Ω
				3.3		8.5	10.5	
				4.2		7.5	8.5	
R _{FLAT}		On-Resistance	V _{IS} = 0 V to V _{CC} , I _{ON} = 8 mA	2.7		1.6		Ω
				3.3		1.5		
		4.2		1.4				
R _{ON}		On-Resistance	V _{IS} = 0 V to V _{CC} , I _{ON} = 8 mA	2.7		2.20		Ω
				3.3		2.45		
		4.2		2.65				

BCT4227 AC ELECTRICAL CHARACTERISTICS

TIMING/FREQUENCY (Typical: T = 25°C, V_{CC} = 3.3 V, R_L = 50Ω, C_L = 5 pF, f = 1 MHz)

Symbol	Pins	Parameter	Test Conditions	V _{CC} (V)	-40°C to +85°C			Unit
					Min	Typ	Max	
t _{ON}	Closed to Open	Turn-ON Time	See test circuit 2	1.65 - 4.5		14	30	ns
t _{OFF}	Open to Closed	Turn-OFF Time	See test circuit 2	1.65 - 4.5		10	20	ns
t _{BBM}		Break-Before-Make Delay	See test circuit 1	1.65 - 4.5	3.0	4.4	7.0	ns
BW		-3 dB Bandwidth	C _L = 5 pF	1.65 - 4.5		650		MHz
			C _L = 0 pF			720		

BCT4227 ISOLATION

(Typical: T = 25°C, V_{CC} = 3.3 V, R_L = 50Ω, C_L = 5 pF)

Symbol	Pins	Parameter	Test Conditions	V _{CC} (V)	-40°C to +85°C			Unit
					Min	Typ	Max	
OIRR	Open	OFF-Isolation	f = 10 MHz	1.65 - 4.5		-58		dB
XTALK	HSD1+ to HSD1-	Non-Adjacent Channel Crosstalk	f = 10 MHz	1.65 - 4.5		-54		dB

BCT4227 CAPACITANCE

(Typical: $T = 25^{\circ}\text{C}$, $V_{CC} = 3.3\text{ V}$, $R_L = 50\ \Omega$, $C_L = 5\text{ pF}$, $f = 1\text{ MHz}$)

Symbol	Pins	Parameter	Test Conditions	-40°C to +85°C			Unit
				Min	Typ	Max	
C_{IN}	OE	Control Pin Input Capacitance	$V_{CC} = 0\text{ V}$	-	3.0	-	pF
C_{ON}	D+ to HSD1+ or HSD2+	ON Capacitance	$V_{CC} = 3.3\text{ V}$; $OE = 0\text{ V}$	-	8.0	-	pF
C_{OFF}	HSD2+, HSD2-	OFF Capacitance	$V_{CC} = V_{IS} = 3.3\text{ V}$; $OE = 3.3\text{ V}$	-	4.5	-	pF

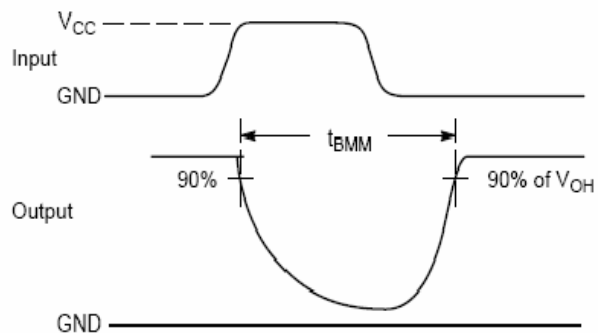
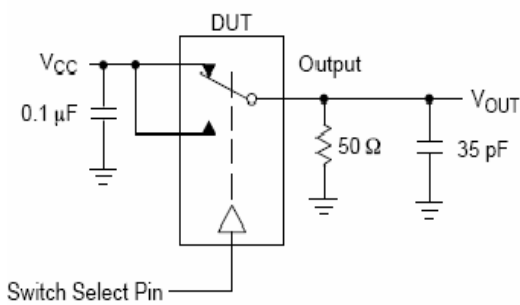

Figure 1. t_{BMM} (Time Break-Before-Make)

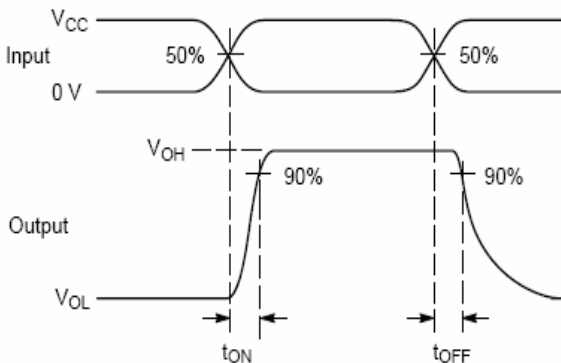
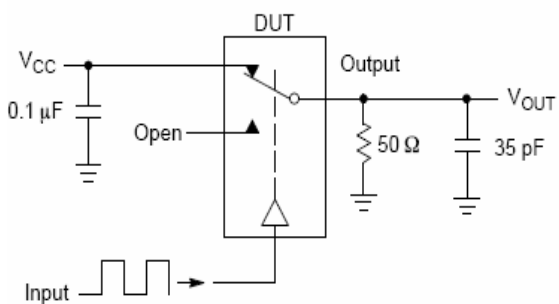

Figure 2. t_{ON} / t_{OFF}

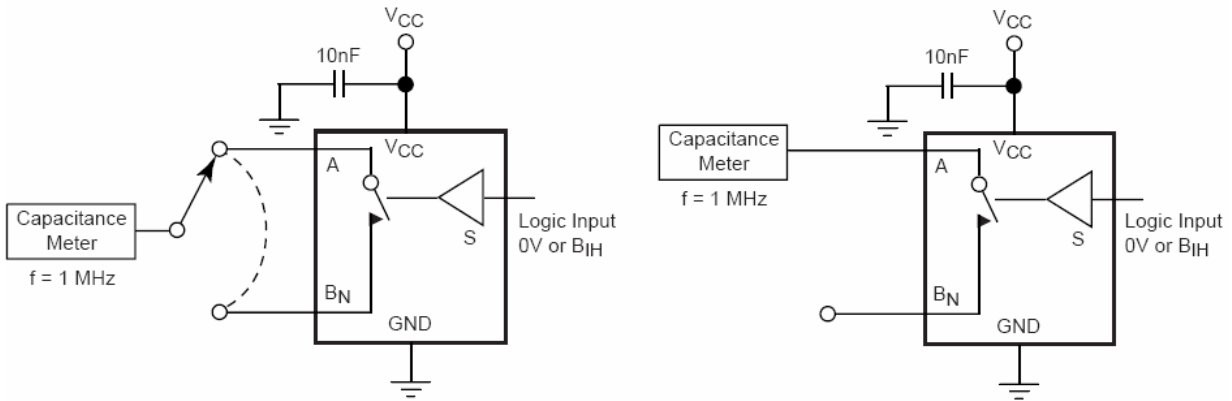

Figure 3. Channel ON/OFF Capacitance

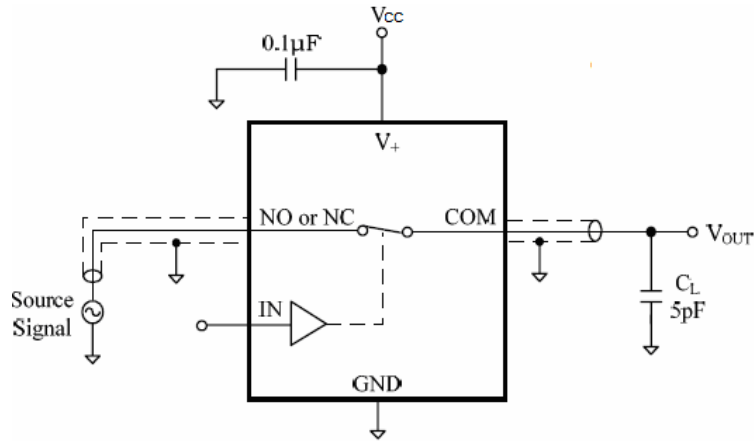

Figure 4. Bandwidth -3dB

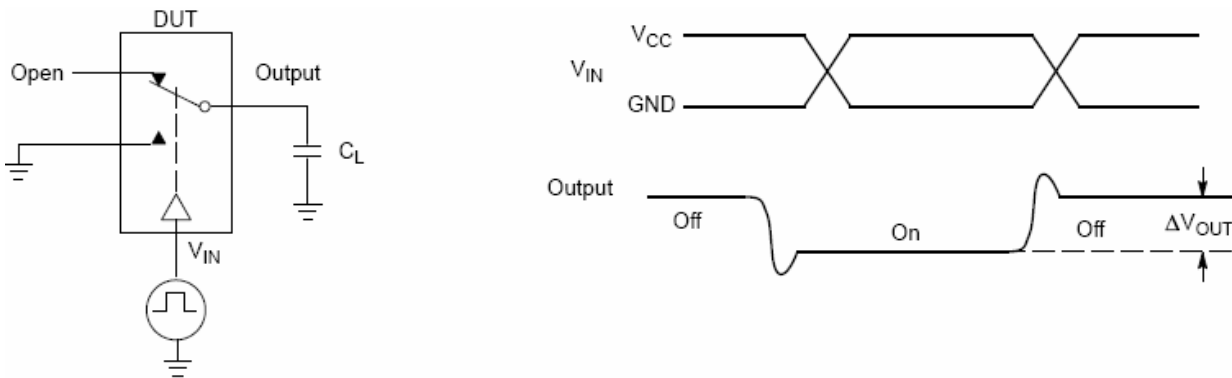

Figure 5. Charge Injecting (Q)

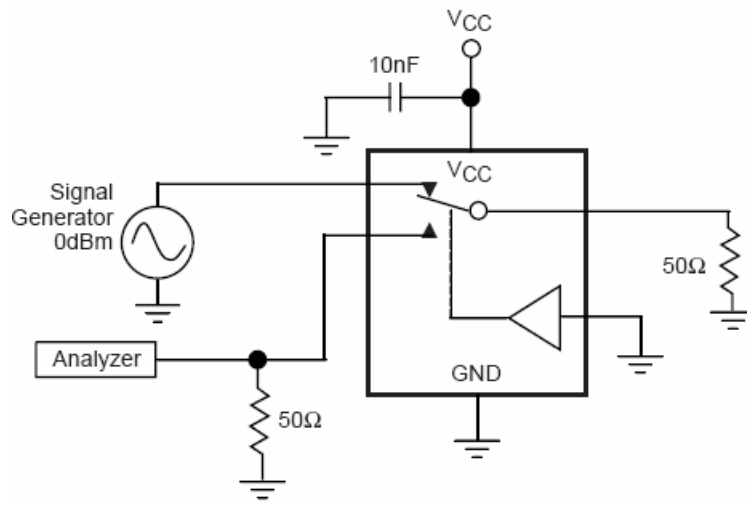

Figure 6. Crosstalk

Applications Information

Logic Inputs

The logic control inputs can be driven up to +3.6V regardless of the supply voltage. For example, given a +3.3V supply, the output enables or select pins may be driven low to 0V and high to 3.6V.

Eye Diagram Measurements

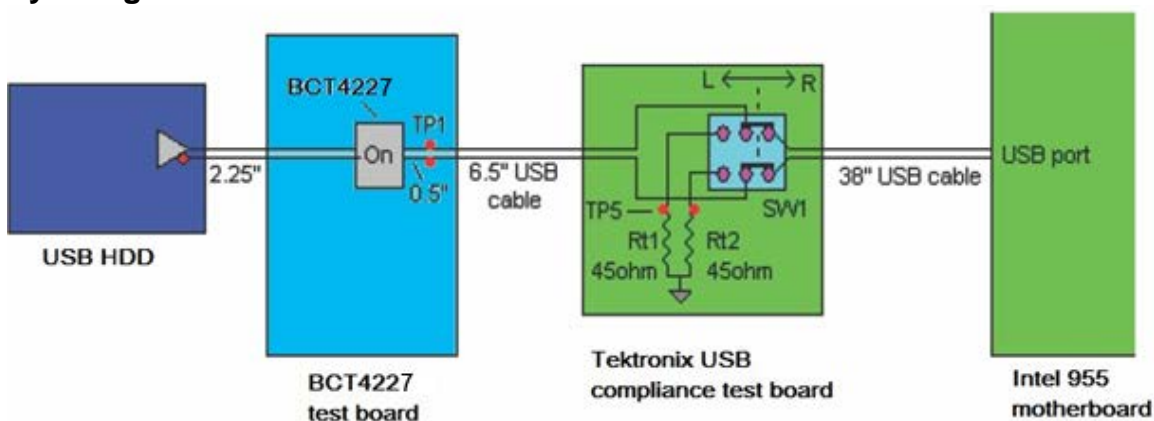

Figure 7: USB2.0 High-speed (480 Mbps) Signal Integrity Test Setup

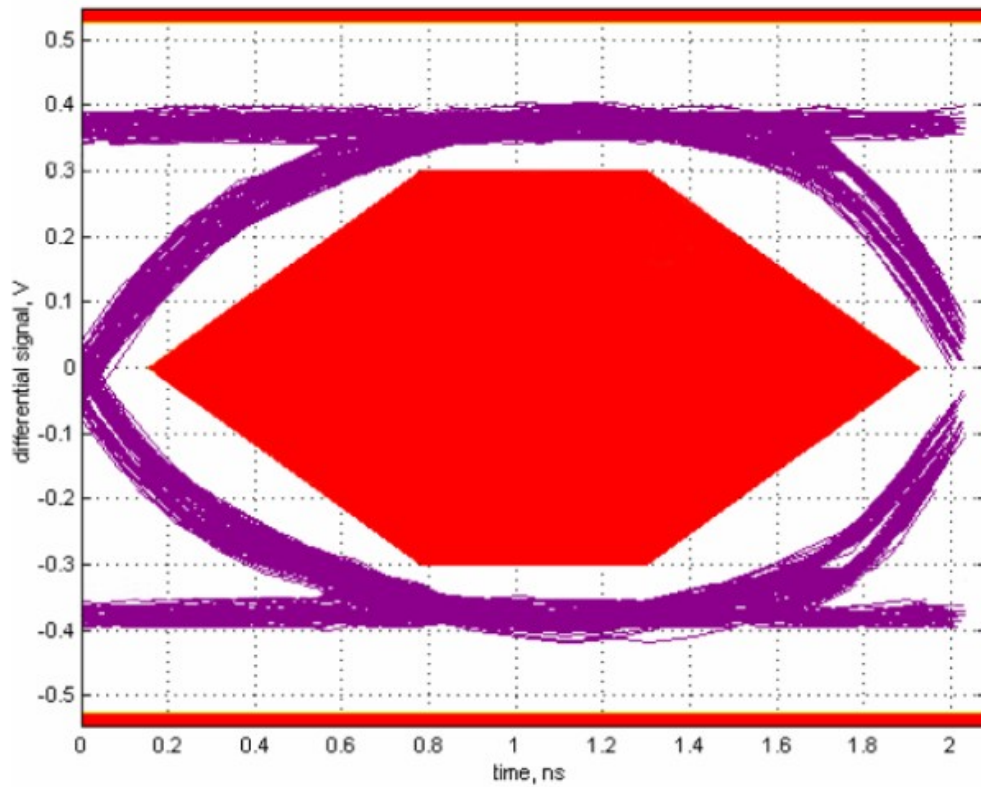
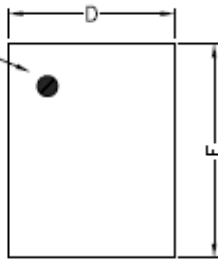

Figure 8: USB 2.0 High Speed (480Mbps) Eye Diagram Test(BCT4227 with Vcc=3.0V)

Package Information

WQFN 1.4X1.8 -10

PIN 1 DOT
BY MARKING



TOP VIEW

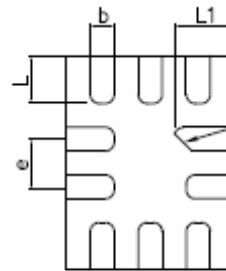

BOTTOM VIEW

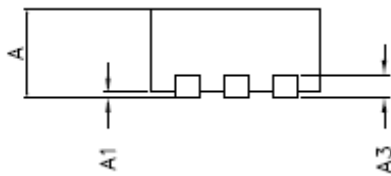

COMMON DIMENSIONS(MM)			
PKG.	UT: ULTRA THIN		
REF.	MIN.	NOM.	MAX.
A	0.50	0.55	0.60
A1	0.00	—	0.05
A3	0.15 REF.		
D	1.35	1.40	1.45
E	1.75	1.80	1.85
b	0.15	0.20	0.25
L	0.30	0.40	0.50
L1	0.40	0.50	0.60
e	0.40 BSC		

Package Information
MSOP10

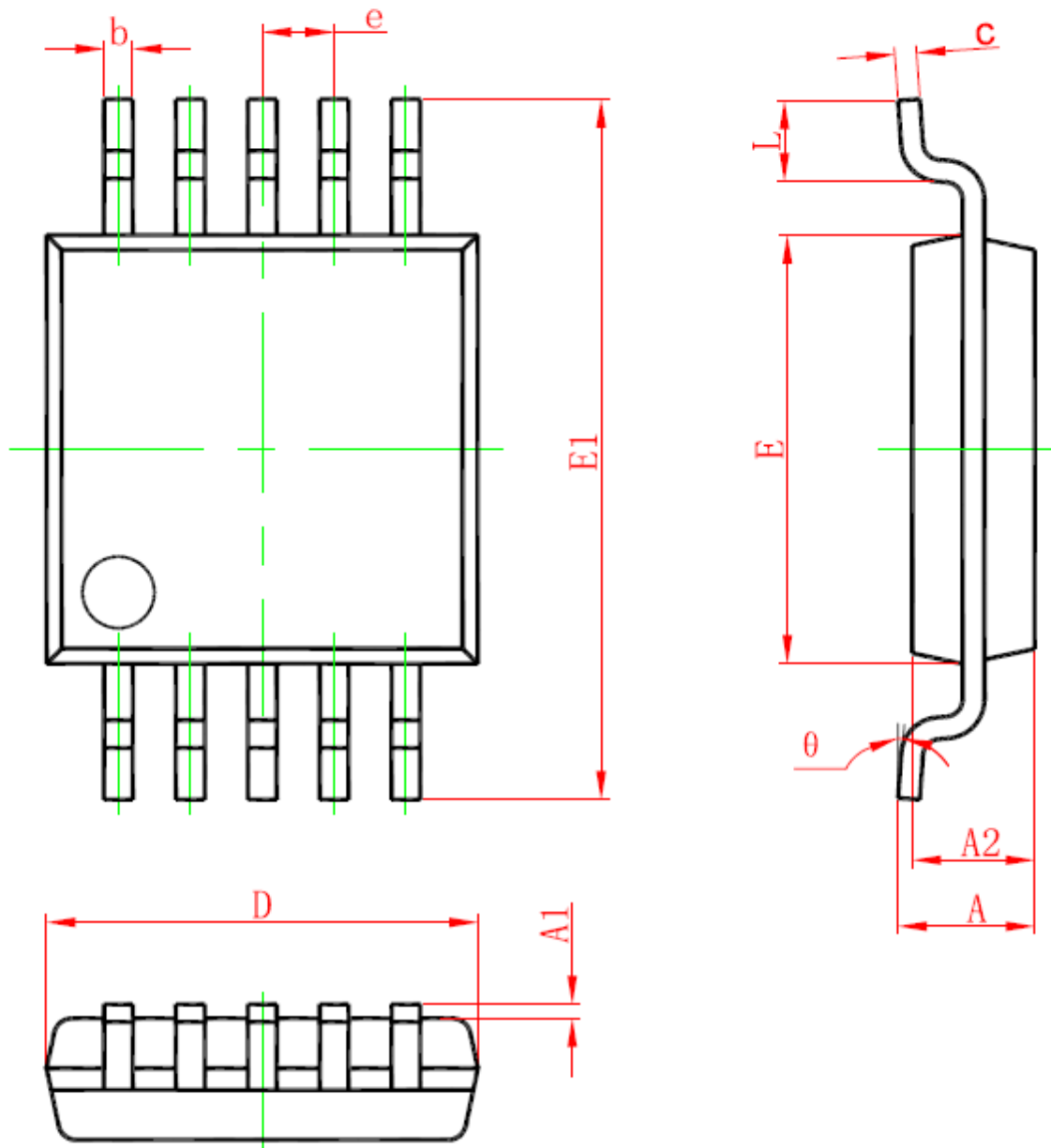



BCT4227 High-Speed DPDT Analog Switch

Symbol	Dimensions In Millimeters		Dimensions In Inches	
	Min	Max	Min	Max
A	0.820	1.100	0.032	0.043
A1	0.020	0.150	0.001	0.006
A2	0.750	0.950	0.030	0.037
b	0.180	0.280	0.007	0.011
c	0.090	0.230	0.004	0.009
D	2.900	3.100	0.114	0.122
e	0.50(BSC)		0.020(BSC)	
E	2.900	3.100	0.114	0.122
E1	4.750	5.050	0.187	0.199
L	0.400	0.800	0.016	0.031
θ	0°	6°	0°	6°

X-ON Electronics

Largest Supplier of Electrical and Electronic Components

Click to view similar products for [Analogue Switch ICs category](#):

Click to view products by [BROADCHIP manufacturer](#):

Other Similar products are found below :

[FSA3051TMX](#) [NLAS4684FCTCG](#) [NLVAS4599DTT1G](#) [NLX2G66DMUTCG](#) [425541DB](#) [425528R](#) [099044FB](#) [MAX4762ETB+](#)
[NLAS5123MNR2G](#) [PI5A4157CEX](#) [PI5A4599BCEX](#) [NLAS4717EPFCT1G](#) [PI5A3167CCEX](#) [DG4051EEN-T1-GE4](#) [SLAS3158MNR2G](#)
[PI5A392AQEX](#) [PI5A392AQE](#) [FSA634UCX](#) [NX3L1T5157GMZ](#) [ADG714BCPZ-REEL7](#) [HT4051ARZ](#) [BL1551B](#) [BCT4227EMB-TR](#)
[SN74LVC1G3157DBVR](#) [SN74LVC1G3157DCKR](#) [ET3157](#) [WSP6582C-12/TR](#) [AIP74LVC1G157GC363.TR](#) [AiP74HC4066TA14.TR](#)
[AIP74HC4052SA16.TR](#) [GS3157-CR](#) [74HC4051](#) [U7SB3157G-SM2-R](#) [CD4051](#) [SGM330A-YS/TR](#) [AIP4052TA16.TR](#) [RS2253XTSS16](#)
[NJG1815K75-TE1](#) [BL2556ACB5TR](#) [UM7222](#) [TC4066BP\(N,F\)](#) [TMUX136RSER](#) [DG302BDJ-E3](#) [PI5A100QEX](#) [HV2733FG-G](#) [HV2701FG-](#)
[G](#) [HV2301FG-G](#) [HV2301FG-G-M931](#) [RS2117YUTQK10](#) [RS2118YUTQK10](#)