



BCT5007

FM Low Noise Amplifier in Alliance with Internal Antenna

BCT5007

FM Low Noise Amplifier in Alliance with Internal Antenna

GENERAL DESCRIPTION

BCT5007 is a Low-Noise-Amplifier (LNA), without earphone or telescopic antenna, re-using GSM antenna to receive FM-radio signal. BCT5007 is characterized with low noise, high gain and high linearity. Typical noise figure is 1.2dB and power gain is 21dB. BCT5007 is powered by 2.6V~3.6V supply with typical 2.8V. EN supports 2.8V / 1.8V GPIO input. BCT5007 integrates RF radio switch inside, implementing high impedance under shut-down condition. Shut-down current is less than 0.1 μ A. BCT5007 is available in slim 2.2mm \times 2.2mm \times 1mm SOT363 package. The specified operating free-air temperature ranges from -40 $^{\circ}$ C to 85 $^{\circ}$ C.

FEATURES

- Without any earphone or telescopic antenna receive FM-radio signal through re-using GSM antenna
- Ultra-low noise figure 1.2dB
- Standard CMOS process technology
- High power gain of 21dB
- High linearity
- EN supports 1.8V/2.8V GPIO
- Supply voltage: 2.6V-3.6V
- Shutdown current:<0.1 μ A
- Slim SOT363 package

APPLICATIONS

Mobile phone
MID/PAD with FM
Mobile audio device

ORDERING INFORMATION

Order Number	Package Type	Temperature Range	Marking	QTY/Reel
BCT5007EXT-TR	SOT363	-40 $^{\circ}$ C to +85 $^{\circ}$ C	BAG	3000

PIN CONFIGURATION (TOP VIEW)

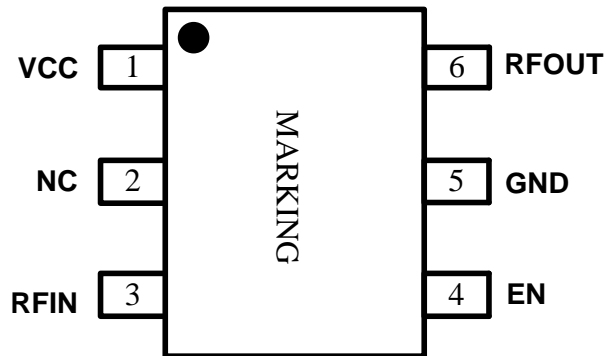

PIN DESCRIPTION

PIN	NAME	FUNCTION
1	VCC	Supply connection.
2	NC	Not connected. Prefer ground.
3	RFIN	RF input.
4	EN	EN(high) supports 1.8V/2.8V IO with internal 150Kohm pull-down resistor.
5	GND	Ground.
6	RFOUT	RF output.

FUNCTION BLOCK DIAGRAM

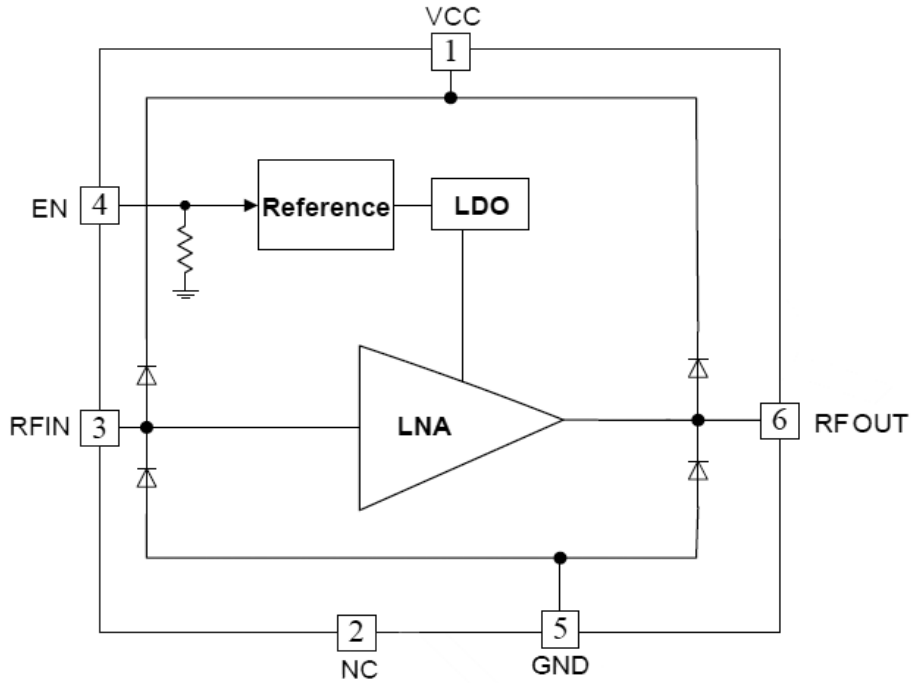

Figure 1. BCT5007 FUNCTION BLOCK DIAGRAM

TYPICAL APPLICATION CIRCUIT

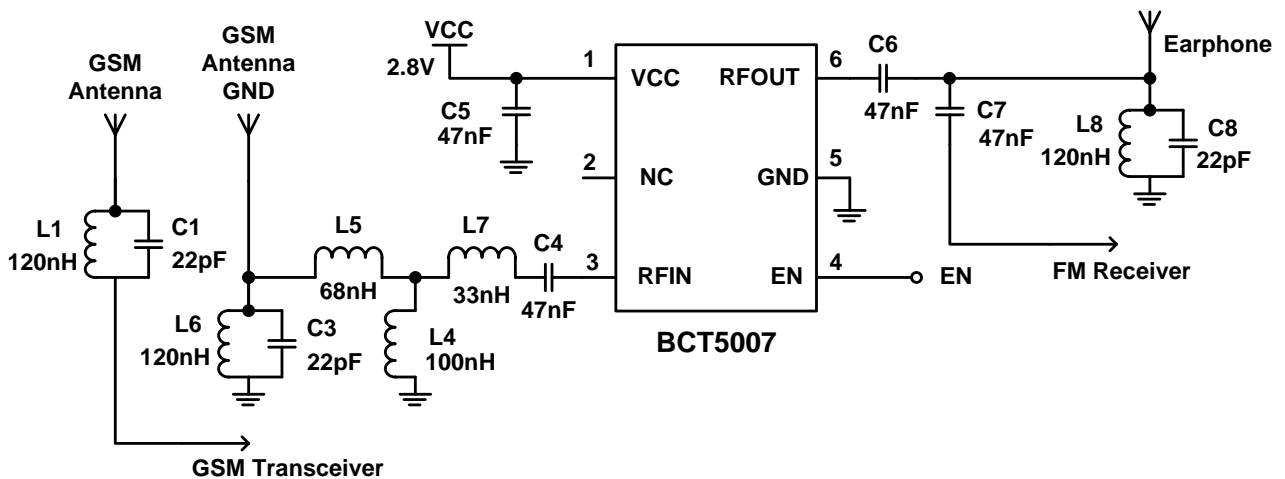

Figure 2. BCT5007 typical application circuit



BCT5007 FM Low Noise Amplifier in Alliance with Internal Antenna

ABSOLUTE MAXIMUM RATINGS

Power Supply VCC	-0.3V to +4.2V
EN pin voltage	-0.3V to +4.2V
Supply maximum current ICC	30mA
RFIN input power Pin	20dBm
Storage Temperature Range.....	-65°C to +150°C
Junction Temperature.....	150°C
Operating Temperature Range.....	-40°C to +85°C
Package Thermal Resistance @ TA=+25°C	
SOT363, θ_{JA}	625°C/W
Lead Temperature (Soldering, 10 sec).....	260°C
ESD Susceptibility	
PINS HBM (human body model)	
ALL PINS.....	4000V

NOTE:

Stresses beyond those listed under "Absolute Maximum Ratings" may cause permanent damage to the device. These are stress ratings only, and functional operation of the device at these or any other conditions beyond those indicated in the operational sections of the specifications is not implied. Exposure to absolute maximum rating conditions for extended periods may affect device reliability.

CAUTION

This integrated circuit can be damaged by ESD if you don't pay attention to ESD protection. Broadchip recommends that all integrated circuits be handled with appropriate precautions. Failure to observe proper handling and installation procedures can cause damage. ESD damage can range from subtle performance degradation to complete device failure. Precision integrated circuits may be more susceptible to damage because very small parametric changes could cause the device not to meet its published specifications.

Broadchip reserves the right to make any change in circuit design, specification or other related things if necessary without notice at any time. Please contact Broadchip sales office to get the latest datasheet.



BCT5007 FM Low Noise Amplifier in Alliance with Internal Antenna

ELECTRICAL CHARACTERISTICS

(VCC= 2.8V, EN=2.8V, T_A=25°C, R_S=R_O=50Ω, frequency=90MHz for typical values unless otherwise specified.)

PARAMETER	SYM	CONDITIONS	MIN	TYP	MAX	UNITS
Supply Voltage	VCC		2.6	2.8	3.6	V
Shut-down Current	ISD	EN=0V		0.1	1	uA
Static Current	IQ	EN=2.8V		9.2		mA
Noise Figure	NF	Input/Output 50ohm		1.2		dB
Input Return Loss	S11	Input/Output 50ohm		-3.7		dB
Reverse Isolation	S12	Input/Output 50ohm		-39.8		dB
Power Gain	S21	Input/Output 50ohm		21		dB
Output Return Loss	S22	Input/Output 50ohm		-20.5		dB
Stability Factor	Kf	Input/Output 50ohm		>1		
In-Band 1dB-compression point	IB P-1dB	Input/Output 50ohm		-20		dBm
Output-Of-Band 1dB-Compression point	OOB P-1dB	Note 2		-7		dBm

NOTE1: Measure IIP3 parameter through two tones of -40dBm/tone with the frequency of 97M and 98MHz.

NOTE2: Input / Output are both 50-ohm; Input signal is composed of in-band 90-MHz signal and out-of-band 900MHz signal. Signal of 90-MHz is fixed to -40-dBm; signal of 900MHz varies and power level is measured when power gain of 90MHz signal drops 1dB.

TYPICAL PERFORMANCE CHARACTERISTICS

(VCC= 2.8V, EN=2.8V, T_A=25°C, R_S=R_O=50Ω, frequency=90MHz for typical values unless otherwise specified.)

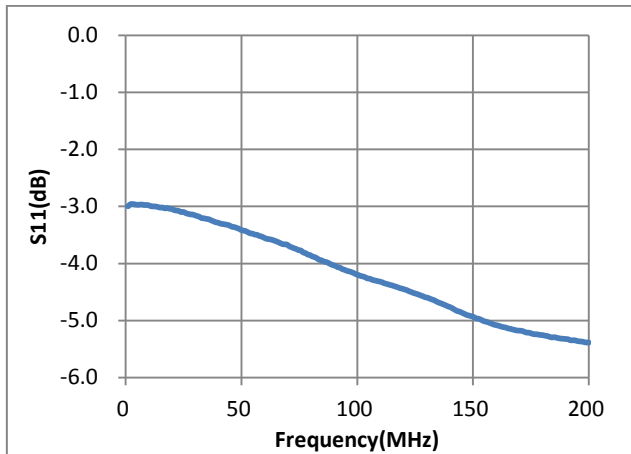

Figure3. Input Return Loss(S11)

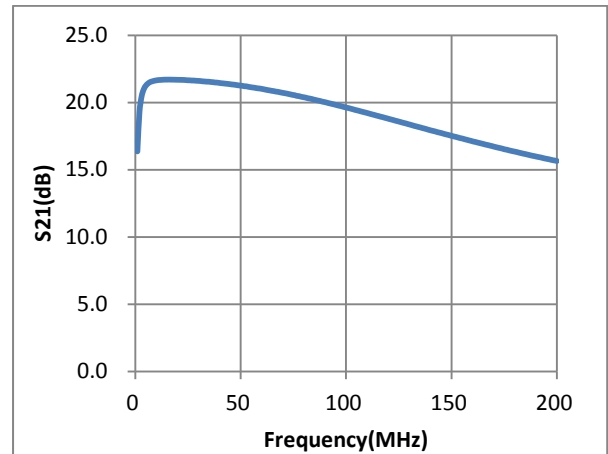

Figure4. Power Gain(S21)

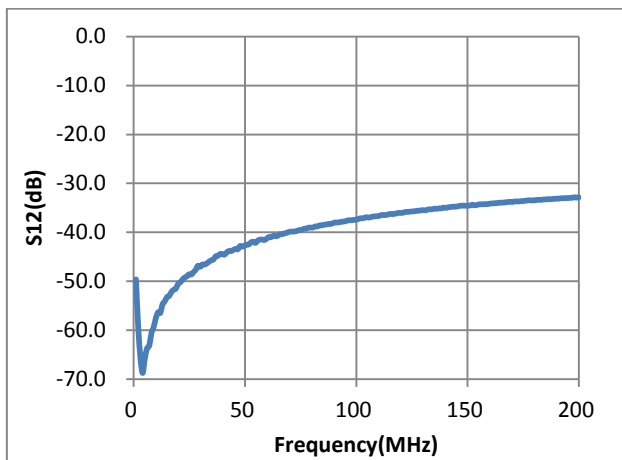

Figure 5. Reverse Isolation(S12)

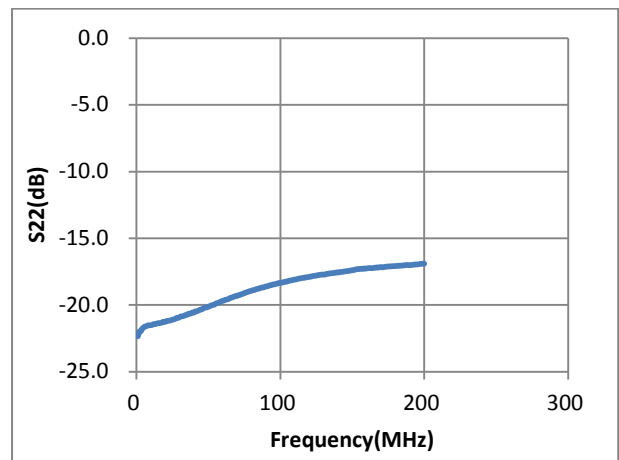

Figure 6. Output Return Loss(S22)

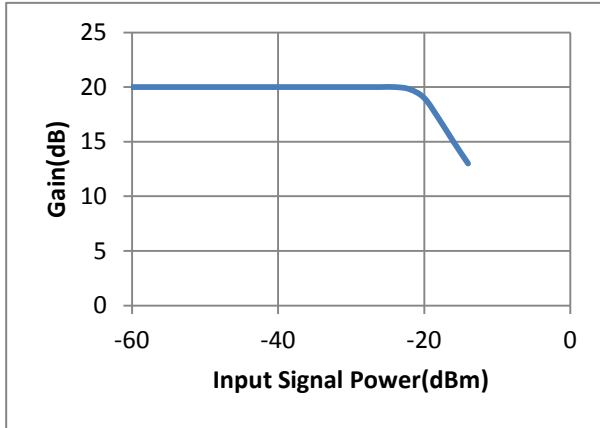

Figure 7. Input P1dB Compression Point(P1dB)

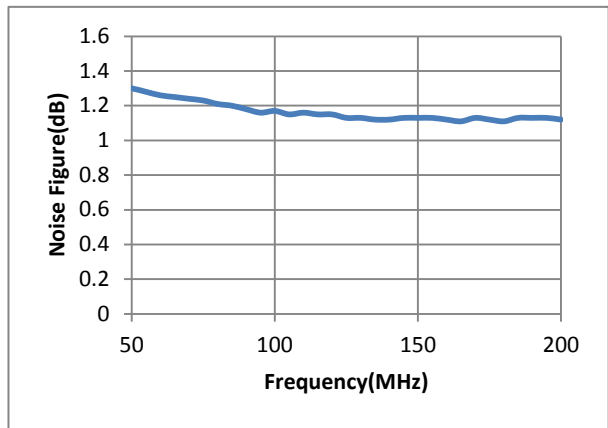

Figure 8. Noise Figure(NF)

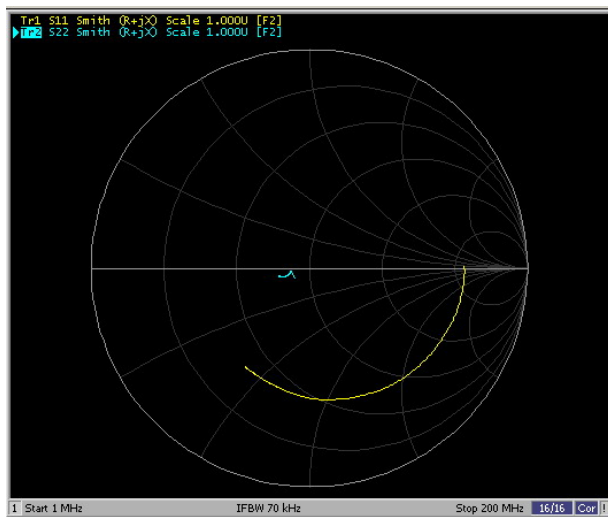

Figure 9. Input/Output Impedance

MEASUREMENT DIAGRAM

Test DC characteristics (Current & Power)

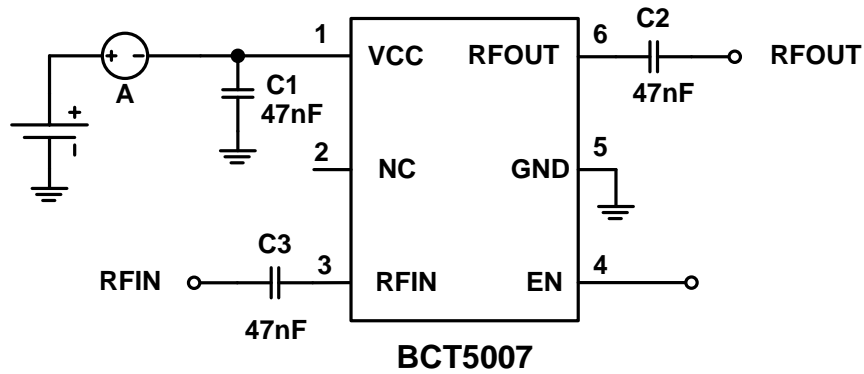

Figure 10. BCT5007 DC Test diagram

Test S-parameter

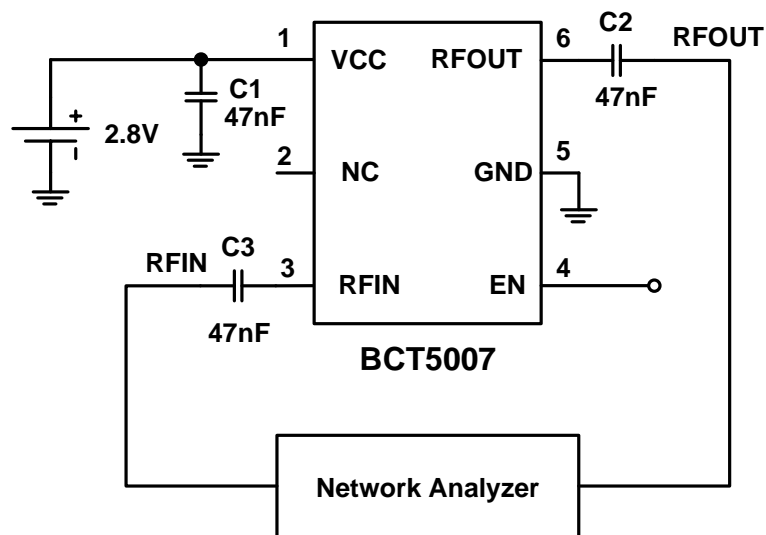

Figure 11. BCT5007 S-parameter measurement Diagram

Test Noise-Figure

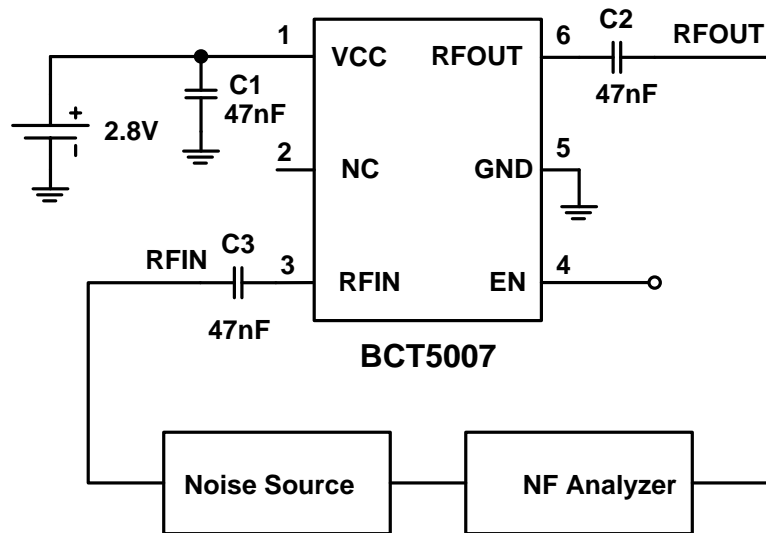

Figure 12. BCT5007 Noise Figure Measurement Diagram

APPLICATION INFORMATION

EN Control

BCT5007 supports earphone. When baseband detects earphone inserting, GPIO will pull down, cutting off BCT5007 to avoid unnecessary power consumption.

Choice of components

Take Figure 2 for example: Filter block near PIFA antenna is composed of L6 and C3. These two components can be removed for Dipole antenna. Typical value of L6 is 120 nH and of C3 is 22 pF.

Filter block of FM signal is composed of C1 and L1. GSM signal could go through and FM signal will be blocked. GSM antenna π -type matching circuit is composed of C2, L3 and L4, adjustable based on GSM antenna characteristics. Typically C1 is 22 pF and L1 is 120 nH.

Matching circuit of FM signal path is composed of C4, L4, L5 and L7. FM signal could go through and GSM signal will be blocked. Typically L4 is 100 nH, L5 is 68 nH and L7 is 33 nH.

C5 is supply filtering capacitor. C6 is DC-blocking capacitor. Both are 47 nF typically.

Only when supporting earphone antenna application, C7 is added with the value of 47 nF.

Table 1 shows recommended inductor type and values. Table 7 shows recommended capacitor type and values.

Table 1 CHOICE OF INDUCTOR

PART No.	TYP.	Q(min)	Frequency	MFR	SIZE
LQG15HS33NJ02	33nH	8	100MHz	Murata	0402
LQG15HS68NJ02	68nH	8	100MHz		0402
LQG15HSR12J02	120nH	8	100MHz		0402
LQG15HR10J02	100nH	8	100MHz		0402
SDCL1005C33NJTDF	33nH	8	100MHz	Sunlord	0402
SDCL1005C68NJTDF	68nH	8	100MHz		0402
SDCL1005CR12JTDF	120nH	8	100MHz		0402
SDCL1005CR10JTDF	100nH	8	100MHz		0402

Table 2 CHOICE OF CAPACITOR

PART No.	TYP.	Voltage	MFR	SIZE
GRM1555C1H220JA01	22pF	25V	Murata	0402
GRM1555C1H390JA01	39pF	25V		0402
GRM1555R71C473KA01	47nF	16V		0402

PACKAGE OUTLINE DIMENSIONS

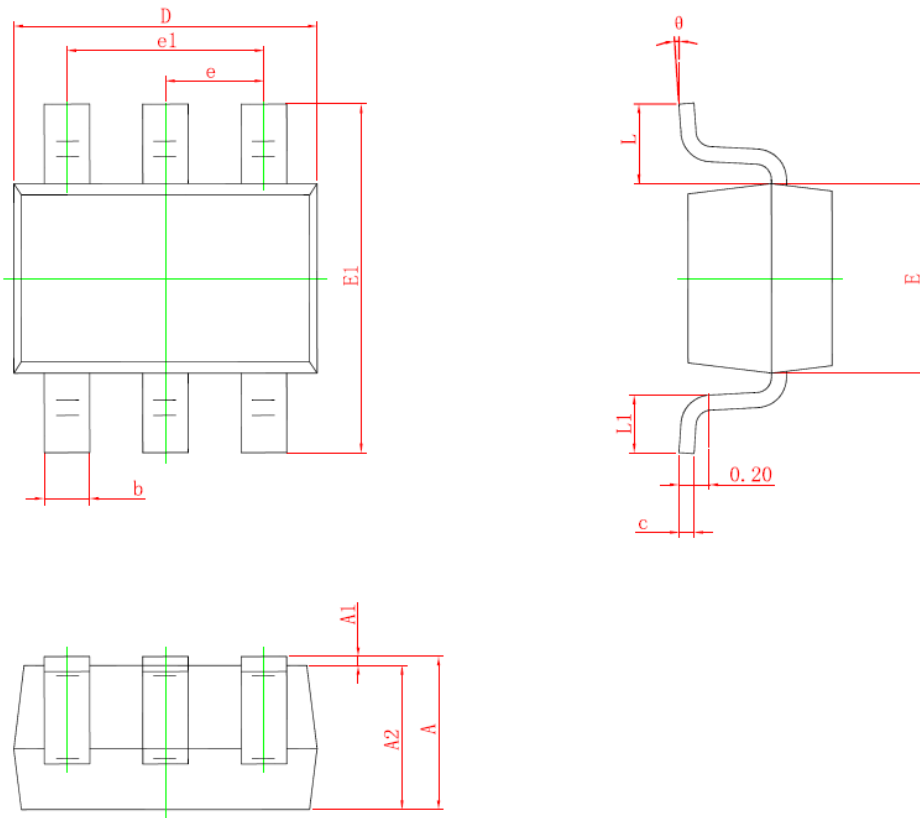

Symbol	Dimensions In Millimeters		Dimensions In Inches	
	Min.	Max.	Min.	Max.
A	0.900	1.100	0.035	0.043
A1	0.000	0.100	0.000	0.004
A2	0.900	1.000	0.035	0.039
b	0.150	0.350	0.006	0.014
c	0.110	0.175	0.004	0.007
D	2.000	2.200	0.079	0.087
E	1.150	1.350	0.045	0.053
E1	2.150	2.450	0.085	0.096
e	0.650 TYP.		0.026 TYP.	
e1	1.200	1.400	0.047	0.055
L	0.525 REF.		0.021 REF.	
L1	0.260	0.460	0.010	0.018
θ	0°	8°	0°	8°

Figure 13. Package outline

TAPING DESCRIPTION

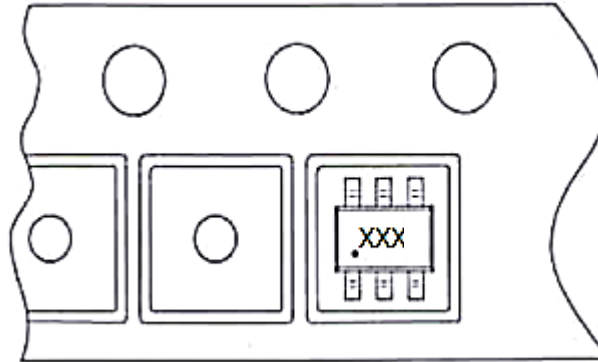

X-ON Electronics

Largest Supplier of Electrical and Electronic Components

Click to view similar products for [Operational Amplifiers - Op Amps](#) category:

Click to view products by [BROADCHIP](#) manufacturer:

Other Similar products are found below :

[430227FB](#) [UPC451G2-A](#) [UPC824G2-A](#) [LT1678IS8](#) [042225DB](#) [058184EB](#) [UPC822G2-A](#) [UPC258G2-A](#) [NCS5651MNTXG](#)
[NCV33202DMR2G](#) [NJM324E](#) [NTE925](#) [5962-9080901MCA*](#) [AZV358MTR-G1](#) [AP4310AUMTR-AG1](#) [HA1630D02MMEL-E](#)
[HA1630S01LPEL-E](#) [AZV358MMTR-G1](#) [SCY33178DR2G](#) [NJU77806F3-TE1](#) [NCV5652MUTWG](#) [NCV20034DR2G](#) [NTE778S](#) [NTE871](#)
[NTE924](#) [NTE937](#) [MCP6V16UT-E/OT](#) [MCP6V17T-E/MS](#) [MCP6V19T-E/ST](#) [SCY6358ADR2G](#) [NCS20282FCTTAG](#) [LM4565FVT-GE2](#)
[EL5420CRZ-T7A](#) [TSV772IQ2T](#) [NJM2100M-TE1](#) [COS2262MR](#) [COS2252MR](#) [COS5532SRB](#) [COS2272MR](#) [LMV358MR](#) [COS6002MR](#)
[LMV358SR](#) [LM358SR](#) [RC4580MM/TR](#) [HGV8544M/TR](#) [HGV8541M/TR](#) [HGV8634M/TR](#) [HGV8542M/TR](#) [HGV8544MT/TR](#)
[LM2904M/TR](#)