



BCT8721/21B/22/24

High-Output-Drive, 15MHz, 9V/ μ s, Rail-to-Rail I/O Op Amps

BCT8721/21B/22/24

High-Output-Drive, 15MHz, 9V/ μ s, Rail-to-Rail I/O Op Amps

GENERAL DESCRIPTION

The BCT872X, high-output drive CMOS op amps, rail-to-rail input and output capability from a single 2.1V to 5.5V supply. These amplifiers exhibit a high slew rate of 9V/ μ s and a gain-bandwidth (GBW) of 15MHz. The BCT872X can drive headset levels, as well as bias an RF power amplifier (PA) in wireless handset applications.

The BCT872X offers low offsets, wide bandwidth, and high-output drive in a space-saving SOT23-5/SOP8/DFN2x2-8L/SOP14 package. These parts are offered over the industrial temperature range (-40°C to +85°C).



FEATURES

- Rail-to-Rail Input and Output
- 15MHz Gain-Bandwidth Product
- High Slew Rate: 9V/ μ s
- 2.1V to 5.5V Single-Supply Operation
- 1.1mA Supply Current per Amplifier
- 100dB Voltage Gain (RL = 100k Ω)
- 85dB Power-Supply Rejection Ratio
- 50mA Output Drive Capability
- Available in SOT23-5/SOP8/DFN2x2-8L /SOP14 package

APPLICATIONS

- RF PA Biasing Controls
- Portable/Battery-Powered Audio Applications
- Audio Hands-Free Car Phones (Kits)
- Laptop/Notebook Computers/TFT Panels
- Set-Top Boxes
- Digital-to-Analog Converter Buffers
- Transformer/Line Drivers
- Motor Drivers

ORDERING INFORMATION

Order Number	Package Type	Temperature Range	Marking	QTY/Reel
BCT8721EUK-TR	SOT23-5	-40°C to +85°C	TAXX	3000
BCT8721BEUK-TR	SOT23-5	-40°C to +85°C	TBXX	3000
BCT8722ESA-TR	SOP8	-40°C to +85°C	 8722 XXXXX	4000
BCT8722ELA-TR	DFN2x2-8L	-40°C to +85°C	 8722 XXXXX	3000
BCT8724ESD-TU	SOP14	-40°C to +85°C	 8724 XXXXX	10000

Note: "XX" & "XXXXX" of Marking is batch code.

PIN CONFIGURATION (TOP VIEW)

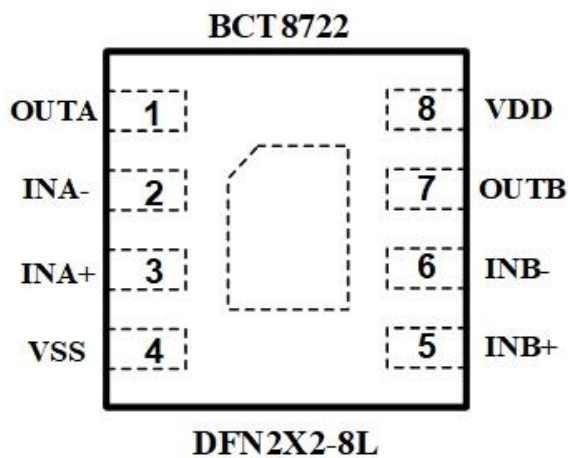
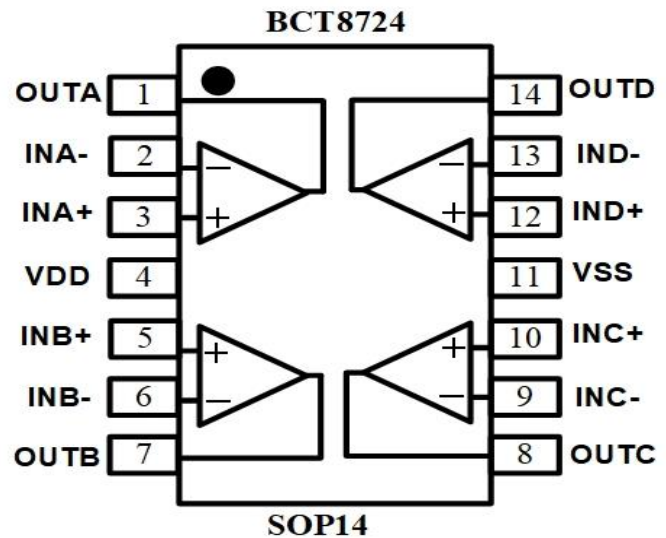
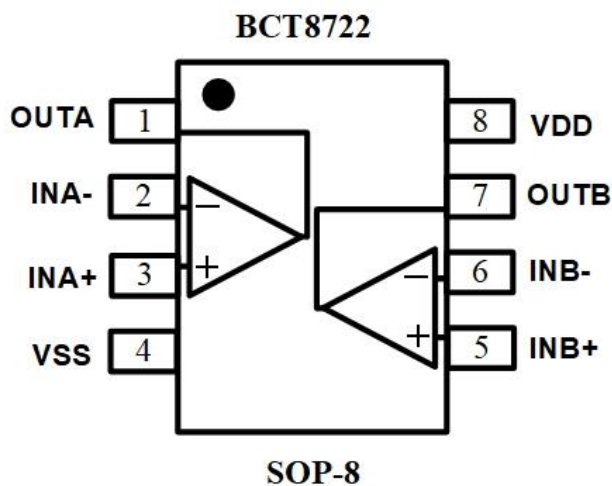
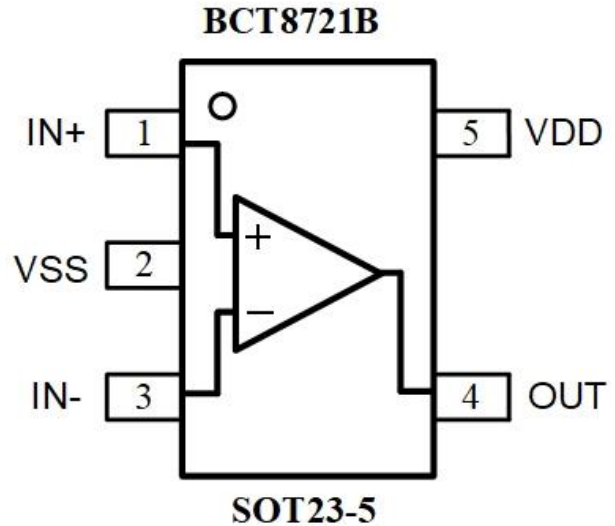
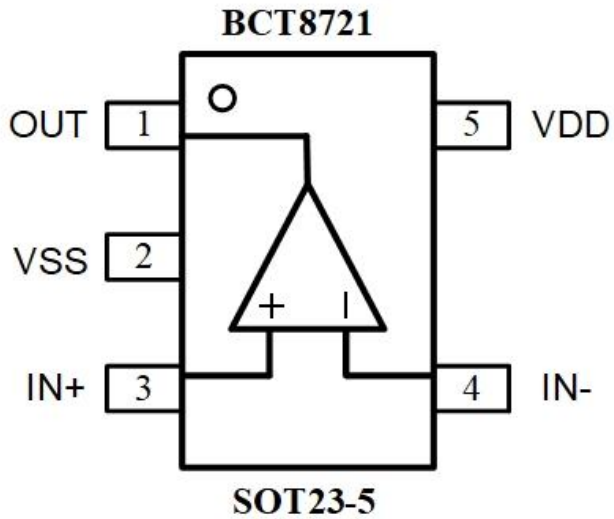



BCT8721/21B/22/24

High-Output-Drive, 15MHz, 9V/ μ s, Rail-to-Rail I/O Op Amps

PIN DESCRIPTION

BCT8721

Pin	Name	Function
1	OUT	Amplifier Output
2	VSS	Negative Supply Input. Connect to ground for single-supply operation.
3	IN+	Non inverting Input to Amplifier
4	IN-	Inverting Input to Amplifier
5	VDD	Positive Supply Input

BCT8721B

Pin	Name	Function
1	IN+	Non inverting Input to Amplifier
2	VSS	Negative Supply Input. Connect to ground for single-supply operation.
3	IN-	Inverting Input to Amplifier
4	OUT	Amplifier Output
5	VDD	Positive Supply Input

BCT8722

Pin	Name	Function
1	OUTA	Amplifier A Output
2	INA-	Inverting Input to Amplifier A
3	INA+	Non inverting Input to Amplifier A
4	VSS	Negative Supply Input. Connect to ground for single-supply operation.
5	INB+	Non inverting Input to Amplifier B
6	INB-	Inverting Input to Amplifier B
7	OUTB	Amplifier B Output
8	VDD	Positive Supply Input

BCT8724

Pin	Name	Function
1	OUTA	Amplifier A Output
2	INA-	Inverting Input to Amplifier A
3	INA+	Non inverting Input to Amplifier A
4	VDD	Positive Supply Input
5	INB+	Non inverting Input to Amplifier B
6	INB-	Inverting Input to Amplifier B
7	OUTB	Amplifier B Output



BCT8721/21B/22/24

High-Output-Drive, 15MHz, 9V/ μ s, Rail-to-Rail I/O Op Amps

8	OUTC	Amplifier C Output
9	INC-	Inverting Input to Amplifier C
10	INC+	Non inverting Input to Amplifier C
11	VSS	Negative Supply Input. Connect to ground for single-supply operation.
12	IND+	Non inverting Input to Amplifier D
13	IND-	Inverting Input to Amplifier D
14	OUTD	Amplifier D Output

ABSOLUTE MAXIMUM RATINGS

Supply Voltage (VDD to VSS)	6V
All Other Pins	(VSS - 0.3V) + (VDD + 0.3V)
Output Short-Circuit Duration to VDD or VSS	1s
Continuous Power Dissipation (TA = +70°C)	
SOT23-5 (derate 3.85mW/°C above +70°C)	308mW
SOP8 (derate 5.55mW/°C above +70°C)	444mW
DFN2x2-8L (derate 10.5mW/°C above +70°C)	840mW
SOP14 (derate 9.09mW/°C above +70°C)	727mW
Operating Temperature Range	-40°C to +85°C
Junction Temperature.....	+150°C
Storage Temperature Range	-65°C to +150°C
Lead Temperature (soldering, 10s)	+260°C
ESD Susceptibility (HBM)	8KV

Note 1:

Stresses beyond those listed under "Absolute Maximum Ratings" may cause permanent damage to the device. These are stress ratings only, and functional operation of the device at these or any other conditions beyond those indicated in the operational sections of the specifications is not implied. Exposure to absolute maximum rating conditions for extended periods may affect device reliability.



BCT8721/21B/22/24

High-Output-Drive, 15MHz, 9V/ μ s, Rail-to-Rail I/O Op Amps

DC ELECTRICAL CHARACTERISTICS

(VDD = 5.0V, VSS = 0V, VCM = VDD/2, VOUT = (VDD/2), RL = connected to (VDD/2), TA = +25°C)

PARAMETER	SYMBOL	CONDITIONS	MIN	TYP	MAX	UNITS	
Operating Supply Voltage Range	VDD	Inferred from PSRR test	2.1		5.5	V	
Input Offset Voltage	VOS			± 0.85	± 6.0	mV	
Input Bias Current	IB	VCM = VSS to VDD		50		pA	
Input Offset Current	IOS	VCM = VSS to VDD		50		pA	
Common-Mode Input Voltage Range	VCM	Inferred from CMRR test	VSS		VDD	V	
Common-Mode Rejection Ratio	CMRR	VSS < VCM < VDD	52	70		dB	
Power-Supply Rejection Ratio	PSRR	VDD = 2.1V to 5.5V	73	85		dB	
Large-Signal Voltage Gain	AVOL	VSS + 0.20 < VOUT < VDD - 0.20V	RL = 100k Ω		100		dB
			RL = 2k Ω	85	98		
			RL = 200 Ω	74	80		
Output Voltage Swing	VOUT	RL = 200 Ω	VDD - VOH		85	130	mV
			VOL - VSS		105	160	
		RL = 2k Ω	VDD - VOH		10	15	
			VOL - VSS		12	18	
Output Source/ Sink Current	IOUT	VOUT short to VDD/2	VDD = 2.1V		50		mA
			VDD = 5.5V		70		
Quiescent Supply Current (per Amplifier)	IDD	VDD = 5.5V, VCM = VDD / 2		1.2	2.3	mA	
		VDD = 2.1V, VCM = VDD / 2		1.1	2.0		



BCT8721/21B/22/24

High-Output-Drive, 15MHz, 9V/ μ s, Rail-to-Rail I/O Op Amps

AC ELECTRICAL CHARACTERISTICS

(VDD = 5.0V, VSS = 0V, VCM = VDD/2, VOUT = (VDD/2), RL = connected to (VDD/2), TA = +25°C)

PARAMETER	SYMBOL	CONDITIONS	MIN	TYP	MAX	UNITS
Gain-Bandwidth Product	GBWP	VCM = VDD/2, VOUT = 0.1VP-P, CL=100pF,		15		MHz
Slew Rate	SR	G=+1, 2V Step, RL=10K, CL=100PF		9.0		V/ μ s
Phase Margin	PM			51		Degrees
Input Capacitance	CIN			8		pF
Voltage Noise Density	en	f = 1kHz		15		nV/ \sqrt Hz
		f = 10kHz		12		
Power-Up Time	tON			5		μ s

PACKAGE OUTLINE DIMENSIONS

SOT23-5

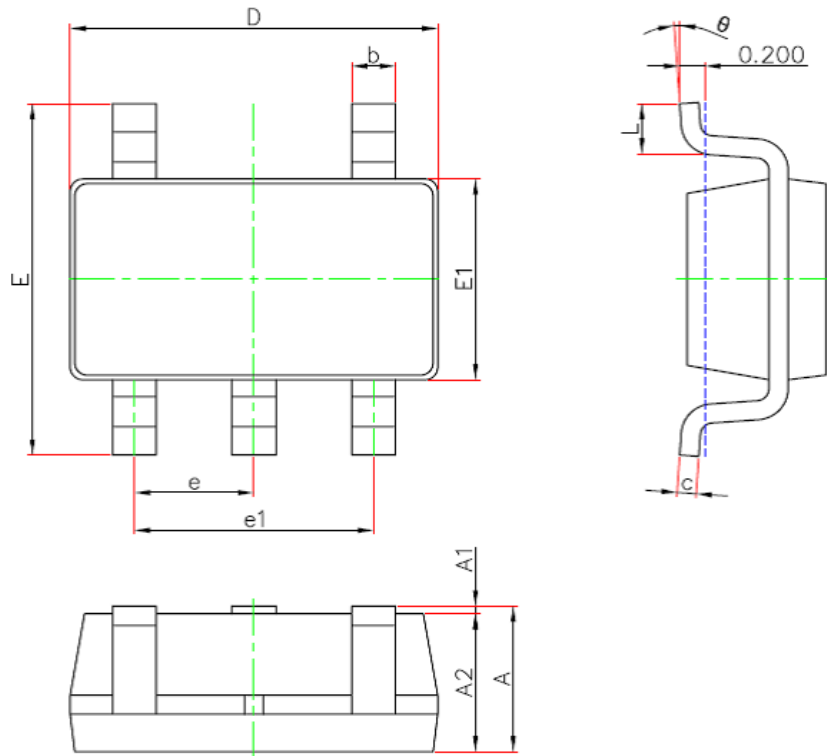

Symbol	Dimensions In Millimeters	
	Min	Max
A	1.05	1.3
A1	0	0.15
A2	1.05	1.15
b	0.28	0.5
c	0.1	0.23
D	2.82	3.02
E1	1.5	1.7
E	2.65	3.05
e	0.95(BSC)	
e1	1.8	2
L	0.3	0.6
θ	0	8°

SOT23-5 Surface Mount Package

SOP8

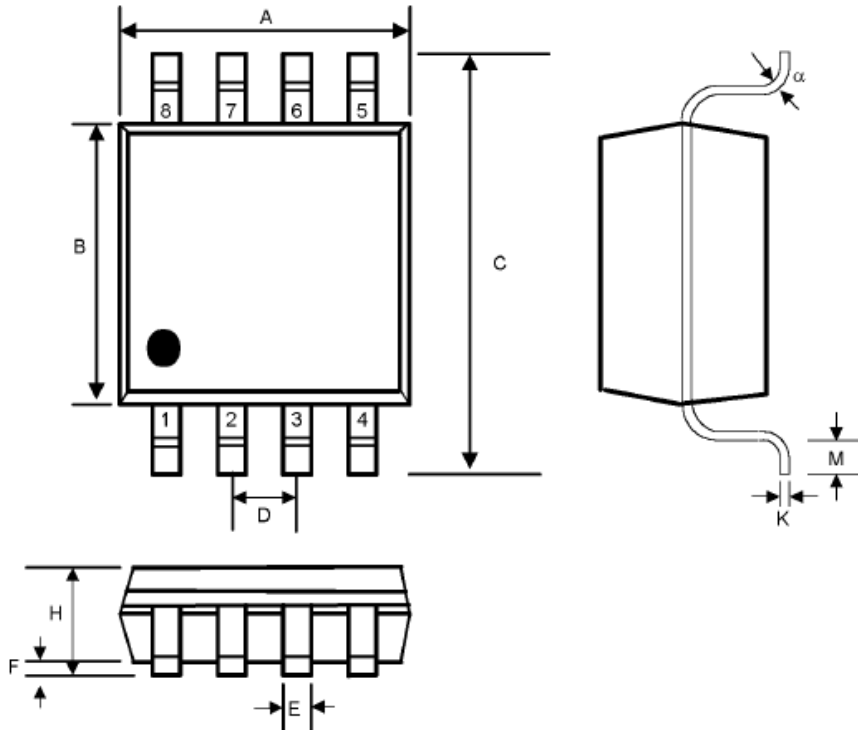

Symbol	Dimensions In Millimeters		Dimensions In Inches	
	Min	Max	Min	Max
A	4.80	5.00	0.188	0.197
B	3.80	4.00	0.149	0.158
C	5.80	6.20	0.228	0.244
D	1.27 BSC		0.050	
E	0.33	0.51	0.013	0.020
F	0.10	0.25	0.004	0.010
H	1.35	1.75	0.053	0.069
K	0.19	0.25	0.007	0.010
M	0.40	1.27	0.016	0.050
α	0°	8°	0°	8°

SOP8 Surface Mount Package

DFN2x2-8L

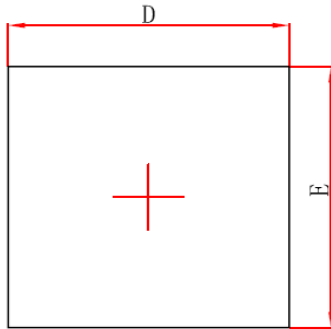

Top View

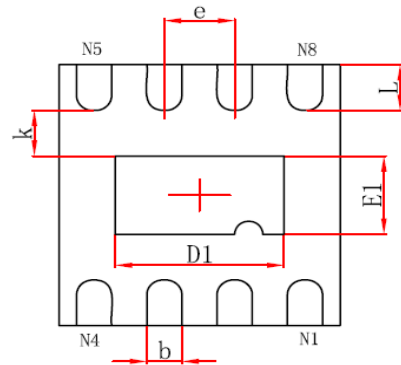

Bottom View

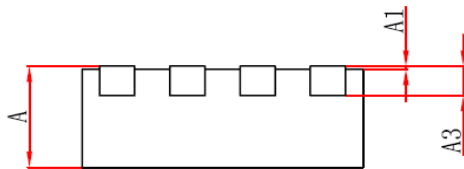

Side View

Symbol	Dimensions In Millimeters		Dimensions In Inches	
	Min	Max	Min	Max
A	0.700/0.800	0.800/0.900	0.028/0.031	0.031/0.035
A1	0.000	0.050	0.000	0.002
A3	0.203REF.		0.008REF.	
D	1.924	2.076	0.076	0.082
E	1.924	2.076	0.076	0.082
D1	1.100	1.300	0.043	0.051
E1	0.500	0.700	0.020	0.028
k	0.200MIN.		0.008MIN.	
b	0.200	0.300	0.008	0.012
e	0.500TYP.		0.020TYP.	
L	0.274	0.426	0.011	0.017

DFN2x2-8L Surface Mount Package

SOP14

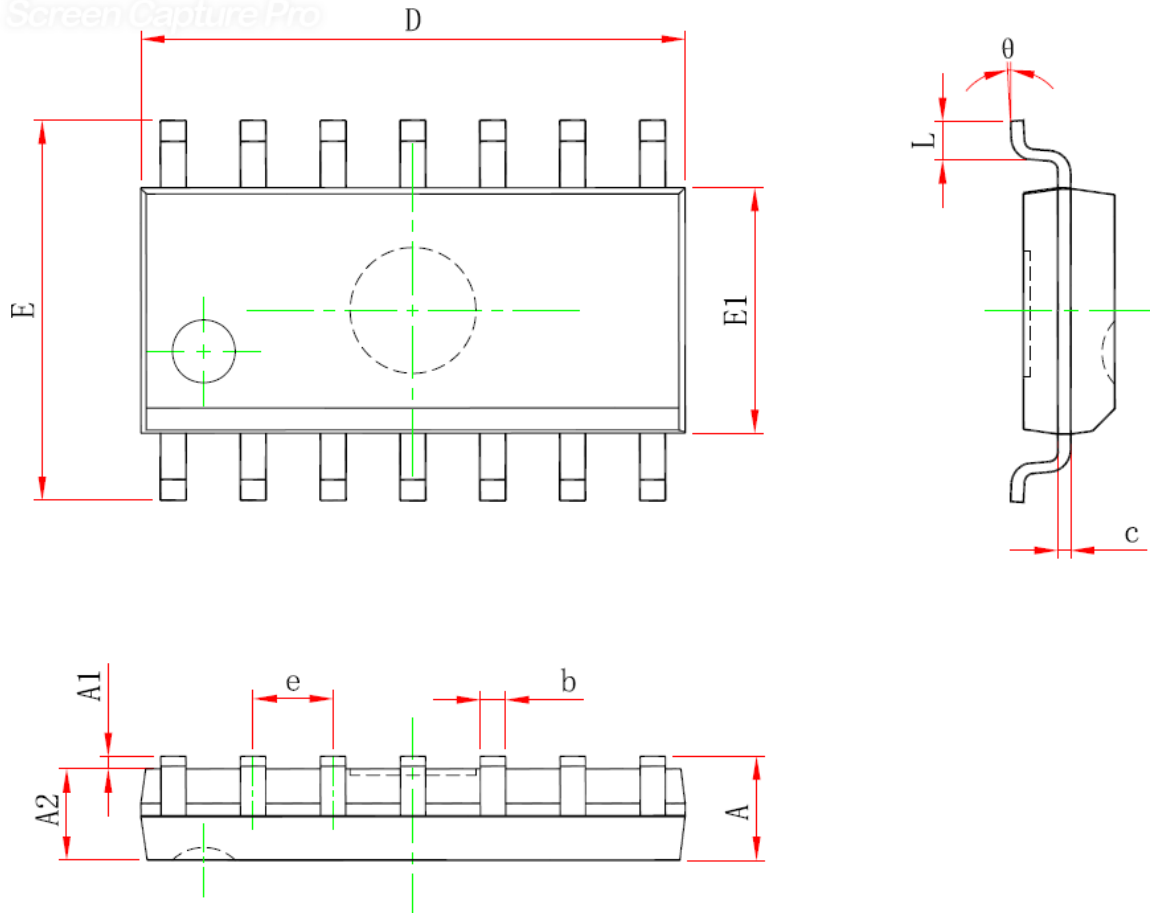

Symbol	Dimensions In Millimeters		Dimensions In Inches	
	Min	Max	Min	Max
A	—	1.750	—	0.069
A1	0.100	0.250	0.004	0.010
A2	1.250	—	0.049	—
b	0.310	0.510	0.012	0.020
c	0.100	0.250	0.004	0.010
D	8.450	8.850	0.333	0.348
E	5.800	6.200	0.228	0.244
E1	3.800	4.000	0.150	0.157
e	1.270(BSC)		0.050(BSC)	
L	0.400	1.270	0.016	0.050
θ	0°	8°	0°	8°

SOP14 Surface Mount Package

LAND PATTERN DATA

SOT23-5

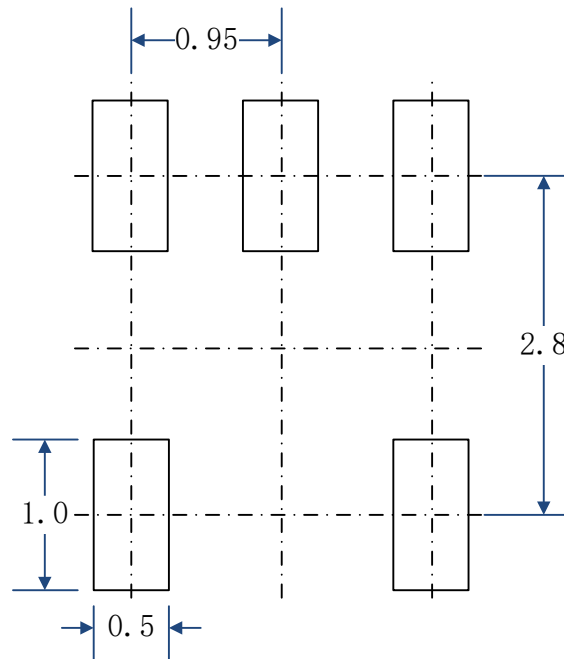

RECOMMENDED PCB LAYOUT PATTERN (Unit: mm)

SOP8

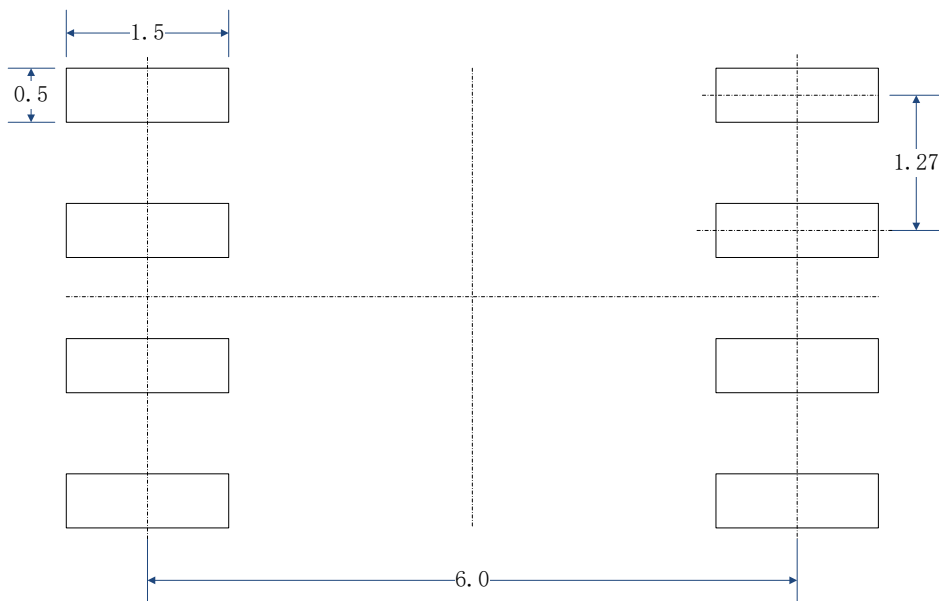

RECOMMENDED PCB LAYOUT PATTERN (Unit: mm)

DFN2x2-8L

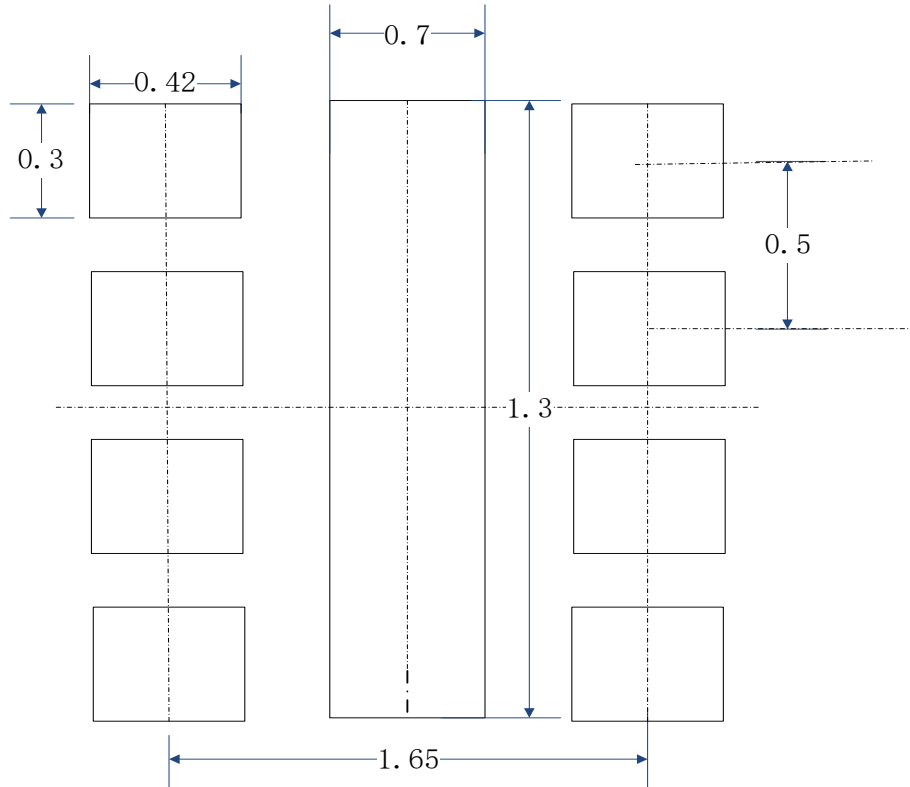

RECOMMENDED PCB LAYOUT PATTERN (Unit: mm)

SOP14

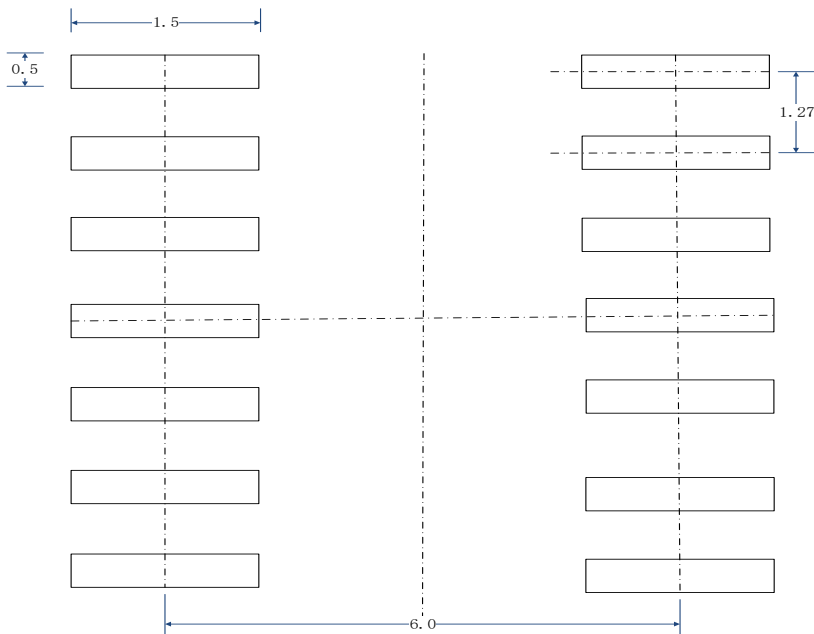

RECOMMENDED PCB LAYOUT PATTERN (Unit: mm)

X-ON Electronics

Largest Supplier of Electrical and Electronic Components

Click to view similar products for [Operational Amplifiers - Op Amps](#) category:

Click to view products by [BROADCHIP](#) manufacturer:

Other Similar products are found below :

[SC2902DTBR2G](#) [430227FB](#) [AZV831KTR-G1](#) [UPC451G2-A](#) [UPC824G2-A](#) [LT1678IS8](#) [042225DB](#) [058184EB](#) [UPC822G2-A](#) [UPC258G2-A](#) [NCS5651MNTXG](#) [NCV33202DMR2G](#) [NJM324E](#) [NTE925](#) [5962-9080901MCA*](#) [AP4310AUMTR-AG1](#) [HA1630D02MMEL-E](#) [HA1630S01LPEL-E](#) [SCY33178DR2G](#) [NJU77806F3-TE1](#) [NCV5652MUTWG](#) [NCV20034DR2G](#) [LM2902EDR2G](#) [NTE778S](#) [NTE871](#) [NTE924](#) [NTE937](#) [MCP6V16UT-E/OT](#) [MCP6V17T-E/MS](#) [MCP6V19T-E/ST](#) [SCY6358ADR2G](#) [LTC2065IUD#PBF](#) [NCS20282FCTTAG](#) [UPC4741G2-E1-A](#) [LM4565FVT-GE2](#) [EL5420CRZ-T7A](#) [TSV791IYLT](#) [TSV772IQ2T](#) [TLV2772QPWR](#) [NJM4556AM-TE1](#) [NJM2068M-TE1](#) [AS324MTR-E1](#) [AS358MMTR-G1](#) [MCP6232T-EMNY](#) [MCP662-E/MF](#) [TLC081AIP](#) [TLC082AIP](#) [TLE2074ACDW](#) [TLV07IDR](#) [TLV2170IDGKT](#)