

Data Sheet

Description

The ACPL-K453 is a single-channel device in an eight-lead miniature footprint.

This diode-transistor optocoupler uses an insulating layer between the light emitting diode and an integrated photo detector to provide electrical insulation between input and output. Separate connections for the photodiode bias and output transistor collector increase the speed up to a hundred times over that of a conventional photo-transistor coupler by reducing the base-collector capacitance.

The ACPL-K453 has a common mode transient immunity of 15,000 V/μs minimum at $V_{CM} = 1500V$ guaranteed.

Functional Diagram

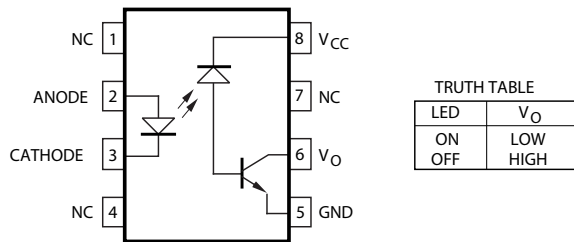

A 0.1 μF bypass capacitor between pins 5 and 8 is recommended.

Schematic

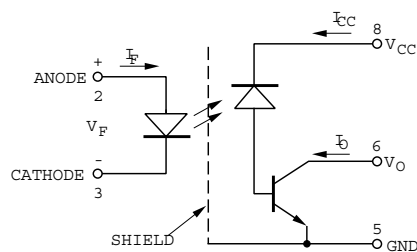

Features

- Package Clearance/Creepage at 8 mm
- Function Compatible with HCPL-4503
- Surface Mountable in 8-pin stretched SO8
- Very High Common Mode Transient Immunity: 15000V/μs at $V_{CM} = 1500V$ guaranteed
- High Speed: 1 Mb/s
- TTL Compatible
- Guaranteed AC and DC Performance over Temperature: 0°C to 70°C
- Open Collector Output
- Safety Approval:
 - UL Recognized with 3750V_{RMS} (5000V_{RMS} for ACPL-W481) for 1 minute per UL1577
 - CSA Approved
 - IEC/EN/DIN EN 60747-5-5 Approved with $V_{IORM} = 1140V_{peak}$

Applications

- Line Receivers - High common mode transient immunity (>15000V/μs) and low input-output capacitance (0.6 pF)
- High Speed Logic Ground Isolation - TTL/TTL, TTL/LTTL, TTL/CMOS, TTL/LSTTL
- Replace Slow Phototransistor Optocouplers
- Replace Pulse Transformers - Save board space and weight
- Analog Signal Ground Isolation - Integrated photo detector provides improved linearity over phototransistor type

CAUTION

It is advised that normal static precautions be taken in handling and assembly of this component to prevent damage and/or degradation which may be induced by ESD.

Ordering Information

ACPL-K453 is UL recognized with $5000V_{RMS}$ for 1 minute per UL1577 and is approved under CSA Component Acceptance Notice #5, File CA 88324.

Part Number	Option	Package	Surface Mount	Tape and Reel	IEC/EN/DIN EN 60747-5-2	Quantity
	RoHS Compliant					
ACPL-K453	-000E	Stretched SO-8	X			80 per tube
	-500E		X	X		1000 per tube
	-060E		X		X	80 per tube
	-560E		X	X	X	1000 per tube

To order, choose a part number from the part number column and combine with the desired option from the option column to form an order entry.

Example 1:

ACPL-K453-560E to order product of Stretched SO-8 package in Tape and Reel packaging with IEC/EN/DIN EN 60747-5-2 Safety Approval in RoHS compliant.

Example 2:

ACPL-K453 to order product of Stretched SO-8 package in tube packaging and RoHS compliant.

Option data sheets are available. Contact your Broadcom sales representative or authorized distributor for information.

Recommended Pb-Free IR Profile

The recommended reflow profile is per JEDEC Standard, J-STD-020 (latest revision). Non-halide flux should be used.

Regulatory Information

The ACPL-K453 is approved by the following organizations:

- IEC/EN/DIN EN 60747-5-2 (Option 060 only): Approval under:
 - IEC 60747-5-2:1997 + A1:2002
 - EN 60747-5-2:2001 + A1:2002
 - DIN EN 60747-5-2 (VDE 0884 Teil 2):2003-01
- UL: Approval under UL 1577, component recognition program up to $V_{ISO} = 5000V_{RMS}$. File E55361.
- CSA: Approval under CSA Component Acceptance Notice #5, File CA 88324.

Package Outline Drawing (Stretched SO-8)

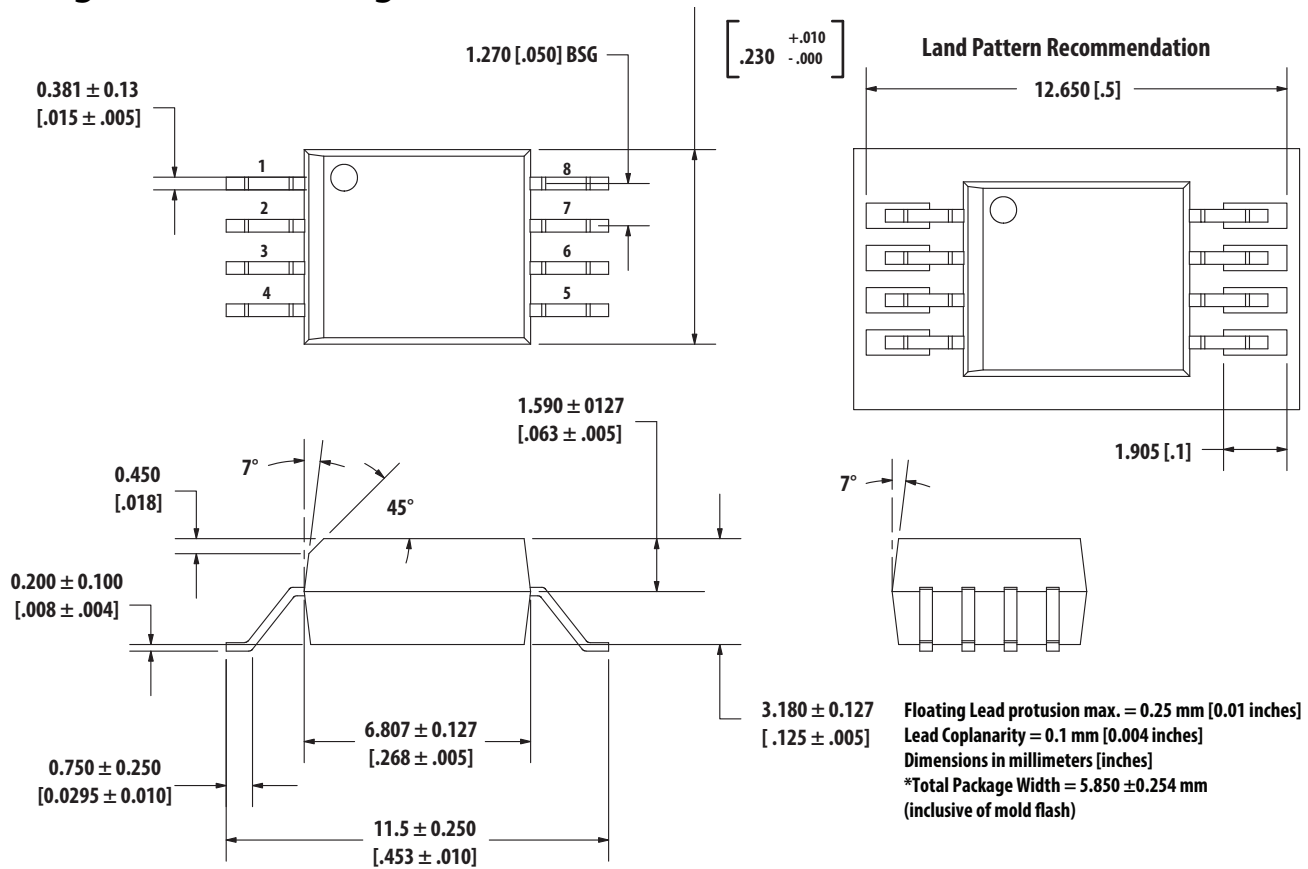

IEC/EN/DIN EN 60747-5-2 Insulation Characteristics (Option 060 Only)

Description	Symbol	Characteristic	Unit
Installation Classification per DIN VDE 0110/1.89, Table 1 for rated mains voltage $\leq 300V_{RMS}$ for rated mains voltage $\leq 450V_{RMS}$ for rated mains voltage $\leq 600V_{RMS}$ for rated mains voltage $\leq 1000V_{RMS}$		I – IV I – III I – III I – II	
Climatic Classification		55/100/21	
Pollution Degree (DIN VDE 0110/39)		2	
Maximum Working Insulation Voltage	V_{IORM}	1140	V_{peak}
Input to Output Test Voltage, Method b ^a $V_{IORM} \times 1.875 = V_{PR}$, 100% Production Test with $t_m = 1$ sec, Partial Discharge < 5 pC	V_{PR}	2137	V_{peak}
Input to Output Test Voltage, Method a ^a $V_{IORM} \times 1.6 = V_{PR}$, Type and Sample Test, $t_m = 10$ sec, Partial Discharge < 5 pC	V_{PR}	1710	V_{peak}
Highest Allowable Overvoltage (Transient Overvoltage $t_{ini} = 60$ sec)	V_{IOTM}	8000	V_{peak}
Safety-limiting Values – maximum values allowed in the event of a failure			
Case Temperature	T_S	175	°C
Input Current	$I_{S, INPUT}$	230	mA
Output Power	$P_{S, OUTPUT}$	600	mW
Insulation Resistance at T_S , $V_{IO} = 500V$	R_S	$> 10^9$	Ω

- a. Refer to the optocoupler section of the Designer's Catalog, under regulatory information (IEC/EN/DIN EN 60747-5-2) for a detailed description of Method a and Method b partial discharge test profiles.

Insulation and Safety Related Specifications

Parameter	Symbol	Value	Unit	Condition
Minimum External Air Gap (Clearance)	L(IO1)	8	mm	Measured from input terminals to output terminals
Minimum External Tracking Path (Creepage)	L(IO2)	8	mm	Measured from input terminals to output terminals
Minimum Internal Plastic Gap (Clearance)		0.08	mm	Through insulation distance conductor to conductor
Tracking Resistance	CTI	175	V	DIN IEC 112/VDE 0303 Part 1
Isolation Group (per DIN VDE 0109)		IIIa		Material Group DIN VDE 0109

Absolute Maximum Ratings

Parameter	Symbol	Min.	Max.	Unit
Storage Temperature	T_S	-55	+125	°C
Operating Temperature	T_A	-55	+100	°C
Average Input Current	I_F		25	mA
Peak Input Current	I_F		50	mA
Peak Transient Input Current (≤ 1 ms pulse width, 300 pps)	I_F		1.0	A
Reverse Input Voltage (Pins 3-2)	V_R		5	V
Input Power Dissipation			45	mW
Average Output Current (Pin 6)	I_O		8	mA
Peak Output Current	I_O		16	mA
Output Voltage (Pins 6-5)	V_O	-0.5	+20	V
Supply Voltage (Pins 8-5)	V_{CC}	-0.5	+30	V
Output Power Dissipation			100	mW
Solder Reflow Temperature Profile	(see Package Outline Drawings section)			

Electrical Specifications

Over recommended temperature ($T_A = 0^\circ\text{C}$ to 70°C) unless otherwise specified.

Parameter	Symbol	Min.	Typ.	Max.	Unit	Test Conditions	Fig.	Note
Current Transfer Ratio	CTR	19	24	50	%	$T_A = 25^\circ\text{C}, V_O = 0.4\text{V}$	1, 2, 4	5
		15	25			$T_A = 25^\circ\text{C}, V_O = 0.5\text{V}$		
Logic Low Output Voltage	V_{OL}		0.1	0.4	V	$T_A = 25^\circ\text{C}, I_O = 3.0\text{ mA}$	VIF = 16 mA	
				0.5		$T_A = 25^\circ\text{C}, I_O = 2.4\text{ mA}$		
Logic High Output Current	I_{OH}		0.003	0.5	μA	$T_A = 25^\circ\text{C}, V_O = V_{CC} = 5.5\text{V}$	$I_F = 0\text{ mA}$	7
			0.01	1		$T_A = 25^\circ\text{C}, V_O = V_{CC} = 15.0\text{V}$		
Logic Low Supply Current	I_{CCL}		50	200		$I_F = 16\text{ mA}, V_O = \text{Open}, V_{CC} = 15\text{ V}$		10
Logic High Supply Current	I_{CCH}		0.02	1		$T_A = 25^\circ\text{C}$	$I_F = 16\text{ mA}, V_O = \text{Open}, V_{CC} = 15\text{ V}$	
				2				
Input Forward Voltage	V_F		1.5	1.7	V	$T_A = 25^\circ\text{C}, I_F = 16\text{ mA}$	3	
Input Reverse Breakdown Voltage	BV_R	5			V	$I_R = 10\text{ }\mu\text{A}$		
Temperature Coefficient of Forward Voltage	$\Delta V_F / \Delta T_A$		-1.6		mV/°C	$I_F = 16\text{ mA}$		
Input Capacitance	C_{IN}		60		pF	$f = 1\text{ MHz}, V_F = 0\text{V}$		4

Switching Specifications

Over recommended temperature ($T_A = 0^\circ\text{C}$ to 70°C) $V_{CC} = 5\text{V}$, $I_F = 16\text{ mA}$ unless otherwise specified.

Parameter	Symbol	Min.	Typ. ^a	Max.	Unit	Test Conditions	Fig.	Note
Propagation Delay Time to Logic Low Output Level	t_{PHL}		0.2	0.8	μs	$T_A = 25^\circ\text{C}$	5, 6, 9	9
				1.0				
Propagation Delay Time to Logic High Output Level	t_{PLH}		0.6	0.8		$T_A = 25^\circ\text{C}$	5, 6, 9	9
				1.0				
Logic High Common Mode Transient Immunity	$ CM_H $	15	30		$\text{kV}/\mu\text{s}$	$V_{\text{CM}} = 1500\text{V}_{\text{p-p}}$	10	8, 9
Logic Low Common Mode Transient Immunity	$ CM_L $	15	30			$V_{\text{CM}} = 1500\text{V}_{\text{p-p}}$		

a. All typicals at $T_A = 25^\circ\text{C}$.

Package Characteristics

Over recommended temperature ($T_A = 0^\circ\text{C}$ to 70°C) unless otherwise specified. All typicals at $T_A = 25^\circ\text{C}$.

Parameter	Symbol	Min.	Typ.	Max.	Unit	Test Conditions	Fig.	Note
Input-Output Momentary Withstand Voltage ^a	V_{ISO}	5000			V_{RMS}	RH < 50%, $t = 1\text{ min.}$ $T_A = 25^\circ\text{C}$		6, 7
Input-Output Resistance	$R_{\text{I-O}}$		10^{12}		Ω	$V_{\text{I-O}} = 500\text{V}_{\text{DC}}$		6
Input-Output Capacitance	$C_{\text{I-O}}$		0.6		pF	$f = 1\text{ MHz}$, $V_{\text{I-O}} = 0\text{V}_{\text{DC}}$		6

a. The Input-Output Momentary Withstand Voltage is a dielectric voltage rating that should not be interpreted as an input-output continuous voltage rating. For the continuous voltage rating refer to the IEC/EN/DIN EN 60747-5-5 Insulation Characteristics Table (if applicable).

Notes:

- Derate linearly above 85°C free-air temperature at a rate of $0.5\text{ mA}/^\circ\text{C}$.
- Derate linearly above 85°C free-air temperature at a rate of $1.0\text{ mA}/^\circ\text{C}$.
- Derate linearly above 85°C free-air temperature at a rate of $1.1\text{ mW}/^\circ\text{C}$.
- Derate linearly above 85°C free-air temperature at a rate of $2.3\text{ mW}/^\circ\text{C}$.
- CURRENT TRANSFER RATIO in percent is defined as the ratio of output collector current, I_O , to the forward LED input current, I_F , times 100.
- Device considered a two terminal device: pins 2 and 3 shorted together, and pins 5, 6, 7, and 8 shorted together.
- In accordance with UL 1577, each optocoupler is proof tested by applying an insulation test voltage $\geq 6000\text{ VRMS}$ for 1 second (leakage detection current limit, $I_{\text{I-O}} \leq 5\text{ }\mu\text{A}$).
- Common transient immunity in a Logic High level is the maximum tolerable (positive) dV_{CM}/dt on the rising edge of the common mode pulse, V_{CM} , to assure that the output will remain in a Logic High state (i.e., $V_O > 2.0\text{V}$). Common mode transient immunity in a Logic Low level is the maximum tolerable (negative) dV_{CM}/dt on the falling edge of the common mode pulse signal, V_{CM} to assure that the output will remain in a Logic Low state (i.e., $V_O < 0.8\text{V}$).
- The $1.9\text{ k}\Omega$ load represents 1 TTL unit load of 1.6 mA and the $5.6\text{ k}\Omega$ pull-up resistor.
- Use of a 0.1 mF bypass capacitor connected between pins 4 and 6 is recommended..

Figure 1 DC and Pulsed Transfer Characteristics

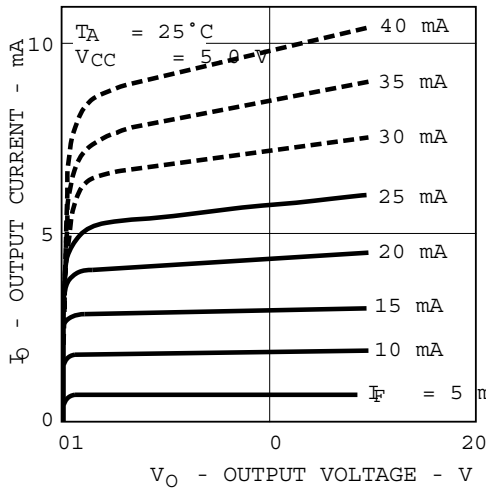

Figure 2 Current Transfer Ratio vs. Input Current

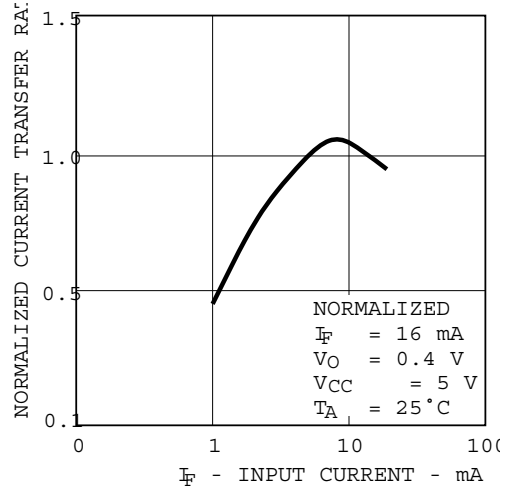

Figure 3 Input Current vs. Forward Voltage

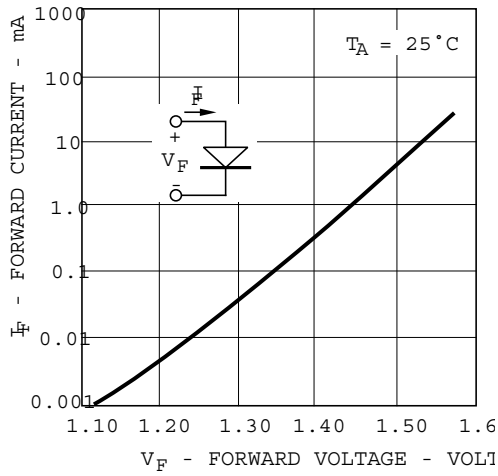

Figure 4 Current Transfer Ratio vs. Temperature

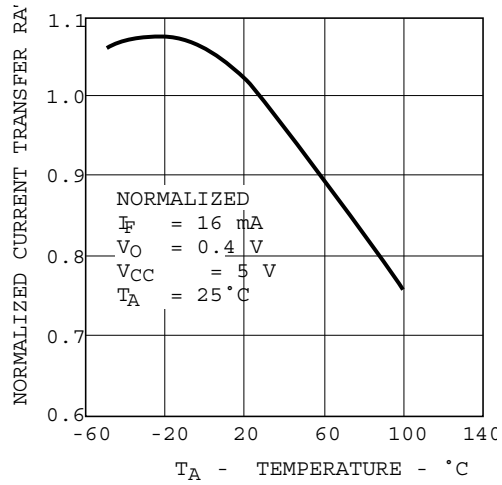

Figure 5 Propagation Delay vs. Temperature

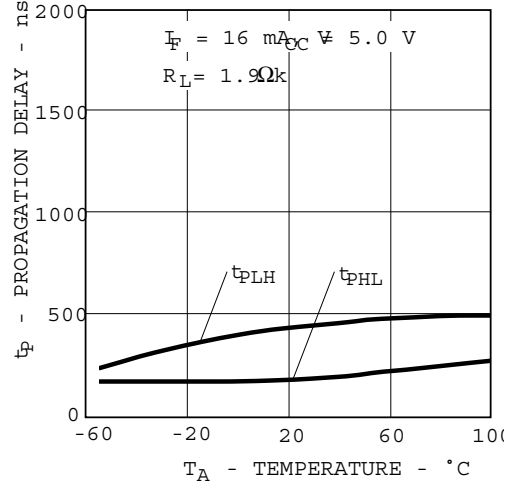

Figure 6 Propagation Delay Time vs. Load Resistance

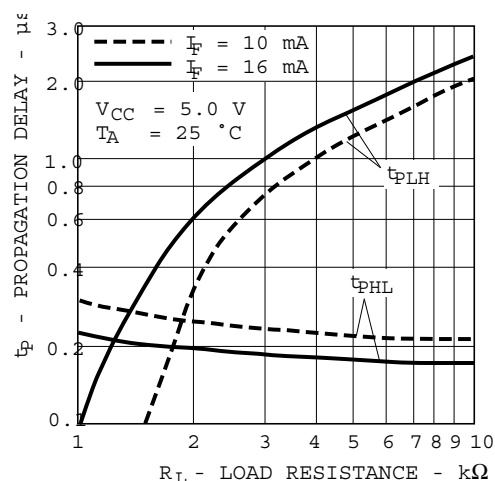

Figure 7 Logic High Output Current vs. Temperature

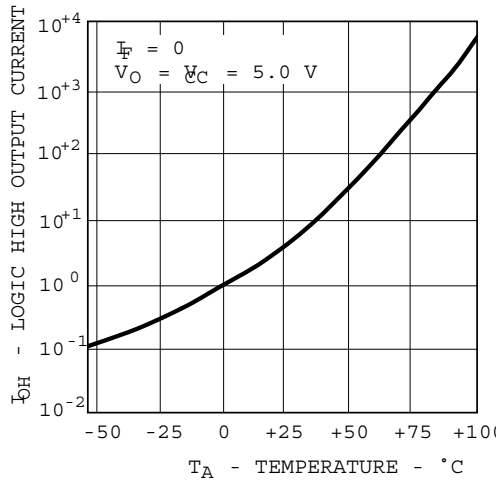

Figure 8 Small-Signal Current Transfer Ratio vs. Quiescent Input Current

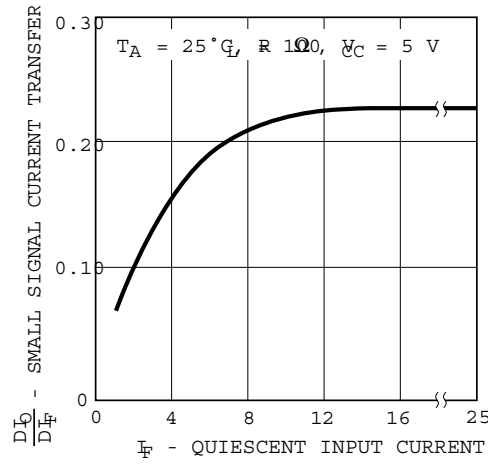

Figure 9 Switching Test Circuit

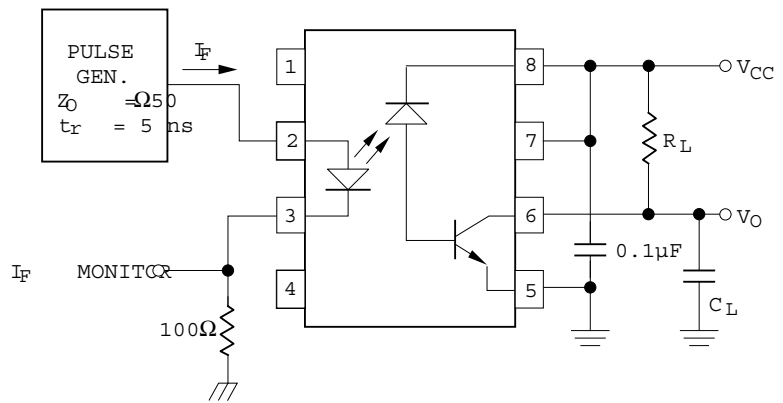
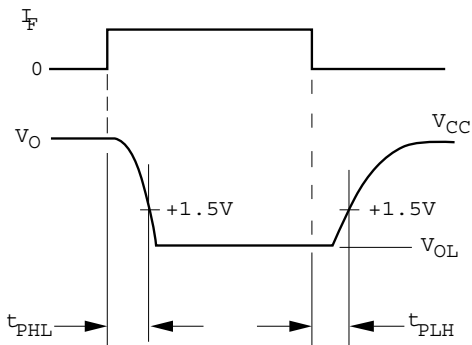
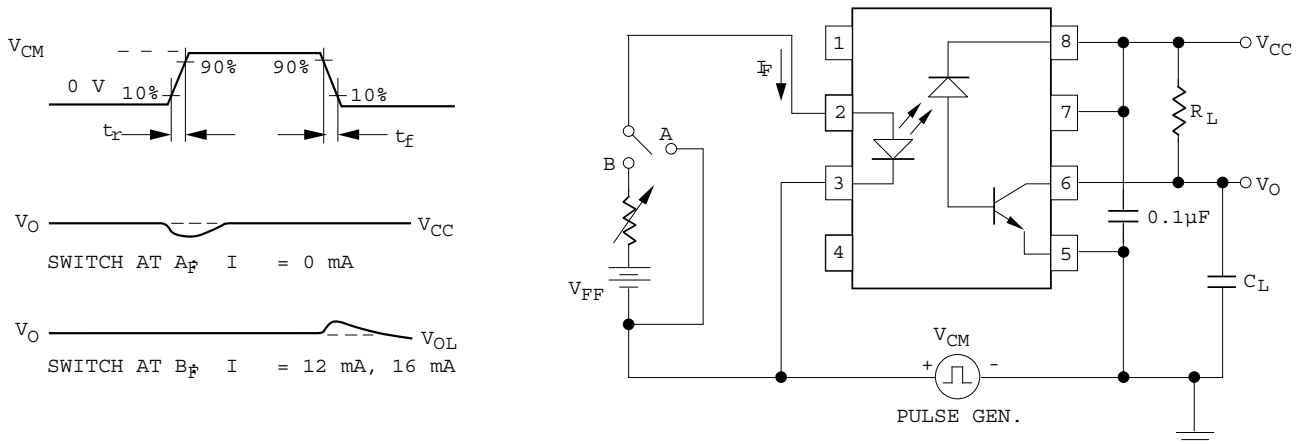

Figure 10 Test Circuit for Transient Immunity and Typical Waveforms



For product information and a complete list of distributors, please go to our web site: www.broadcom.com.

Broadcom, the pulse logo, Connecting everything, Avago Technologies, Avago, and the A logo are among the trademarks of Broadcom and/or its affiliates in the United States, certain other countries and/or the EU.

Copyright © 2017 by Broadcom. All Rights Reserved.

The term "Broadcom" refers to Broadcom Limited and/or its subsidiaries. For more information, please visit www.broadcom.com.

Broadcom reserves the right to make changes without further notice to any products or data herein to improve reliability, function, or design.

Information furnished by Broadcom is believed to be accurate and reliable. However, Broadcom does not assume any liability arising out of the application or use of this information, nor the application or use of any product or circuit described herein, neither does it convey any license under its patent rights nor the rights of others.

AV02-1302EN – June 16, 2017



X-ON Electronics

Largest Supplier of Electrical and Electronic Components

Click to view similar products for [High Speed Optocouplers](#) category:

Click to view products by [Broadcom](#) manufacturer:

Other Similar products are found below :

[TLP558\(F\)](#) [JAN4N24](#) [610737H](#) [HCPL2630M](#) [HCPL2731SM](#) [PS9817A-1-F3-AX](#) [TLP2766A\(LF4,E](#) [TLP281-4](#) [TLP290\(V4GBTP,SE\(T](#)
[PS9121-F3-AX](#) [PS9123-F3-AX](#) [TLP5774H\(TP4,E](#) [TLP5771H\(TP,E](#) [HCPL2531S](#) [HCPL2631SD](#) [HCPL-4661-500E](#) [TLP118\(TPL,E\)](#)
[TLP521-2XGB](#) [TLP621-2XGB](#) [4N46-300E](#) [JANTXV4N24U](#) [SFH6318T](#) [6N135-300E](#) [TIL198](#) [TLP2309\(TPL,E\)](#) [TLP2355\(TPL,E](#)
[TLP2391\(E\(T](#) [TLP521-4GR](#) [TLP521-4XGB](#) [TLP621-4X](#) [TLP621XSM](#) [IS281-4GB](#) [IS2805-4](#) [IS181GR](#) [ICPL2631](#) [ICPL2630](#) [ICPL2531](#)
[ICPL2601](#) [TLP2301\(E\(T](#) [TLP714\(F\)](#) [TLP754\(F\)](#) [FOD260LSDV](#) [ACPL-M50L-000E](#) [ACPL-M21L-500E](#) [ACPL-064L-500E](#) [PS2501-1XSM](#)
[PS2505-1](#) [PS2913-1-F3-AX](#) [PS9821-2-F3-AX](#) [FOD0721R2](#)