

AEAT-601B

Incremental Magnetic Encoder



Data Sheet



Description

Avago Technologies' Incremental Magnetic Encoder provides an integrated solution for angular detection within a complete 360° rotation. The use of magnetic technology for motion control and sensing activities eliminates mechanical contact and enables this device to be free from mechanical wear and tear. Three-channel output provides an additional index channel for every full rotation or revolution of 360°. An additional advantage is that the encoders upper rotational speed limit is typically only limited by the application's bearing speed.

Exploded View

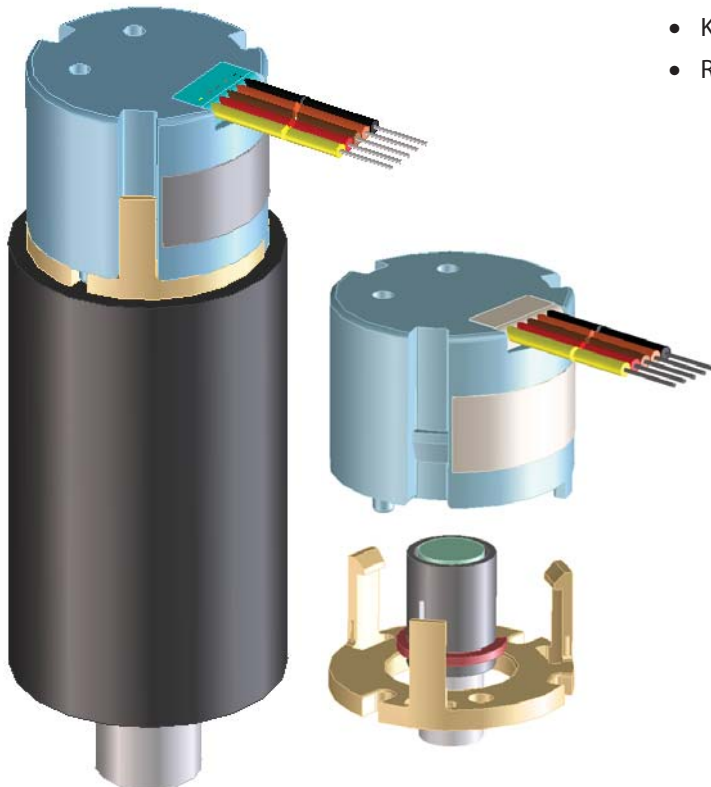

Features

- Resolution of 256 counts per revolution (CPR)
- Contactless sensing technology
- Wide temperature range from -40° to 125°C
- 3-channel output
- Single 5V supply
- Easy assembly and no signal adjustment required
- Direct connectivity through cable output
- RoHS compliant

Applications

- Speed detection
- Knob control
- Rotary encoders

Table 1. Absolute Maximum Ratings [1, 2]

Parameter	Symbol	Limits	Units
DC Supply Voltage at pin $V_{DD} = 5V$	V_{DD}	-0.3 to + 7	V
Input Voltage	V_i	-0.3 to $V_{DD}+0.3$	V
Storage Temperature	T_{stg}	-40 to 125	°C

Notes:

1. Stresses greater than those listed under Absolute Maximum Ratings may cause permanent damage to the device. This is stress rating only and functional operation of the device at these or any other conditions above those indicated in the operational sections of this specification is not implied.
2. Exposure to absolute maximum rating conditions for extended periods may affect reliability.

Table 2. Recommended Operating Condition

Parameters	Symbols	Values	Units	Notes
DC Supply Voltage at pin $V_{DD} = 5V$	V_{DD}	+4.5 / +5.5	V	
Operating Temperature	T_{amb}	40/125	°C	
Rotational Speed :	Mechanical (max)	12000	RPM	
	Electrical (max)	7000	RPM	

Notes:

1. Under recommended mounting and tolerance, and mechanical shaft play, the incremental encoder's quadrature output (quarter cycle phase shift between Channel-A and Channel-B) is always maintained. The dynamic performance of the encoder output are depicted in the figures under Encoding Characteristic.
2. The magnetic incremental output has a fixed hysteresis of 0.7 degrees for all different CPR options (equivalent to 2 quadrature counts at 256 CPR or 0.5 quadrature count at 64 CPR).
3. The quadrature decoding of both the Channel-A and Channel-B would ensure that the incremental counts are maintained even when there is transition noise due to fluctuation of the magnetic field strength.

Table 3. DC Characteristics

DC Characteristics over Recommended Operating Range, typical at 25 °C

Parameter	Symbol	Condition	Values			Units	Notes
			Min	Typ.	Max		
V_{DD} Supply Current	I_{DD}			16	20	mA	
Output High Voltage	V_{OH}		$V_{DD}-0.5$			V	
Output Low Voltage	V_{OL}				$V_{SS}+0.4$	V	
Output Current	I_O				4	mA	V_{DD} pin = 4.5V

AEAT-601B Performance Characteristics

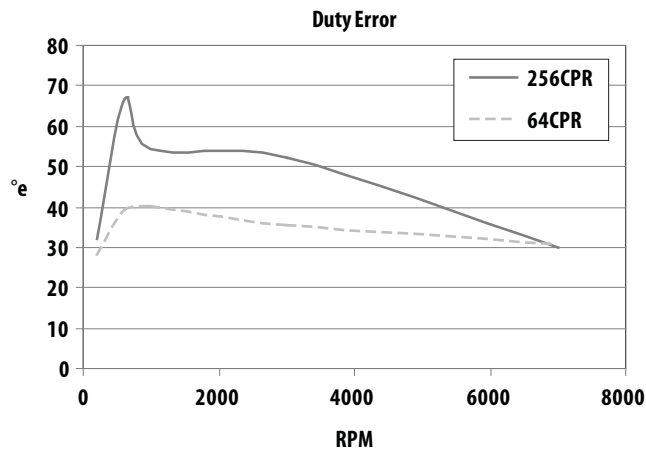
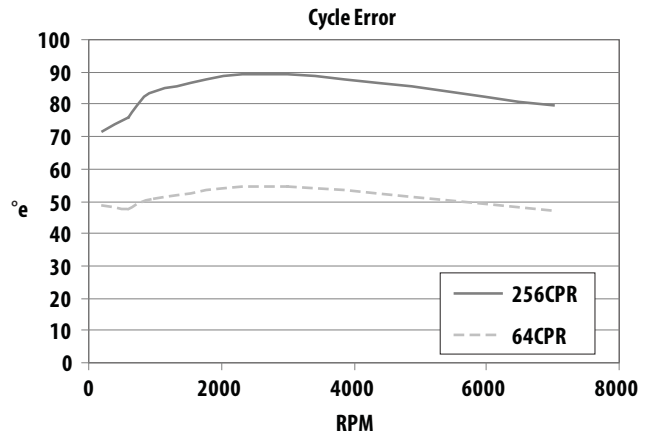
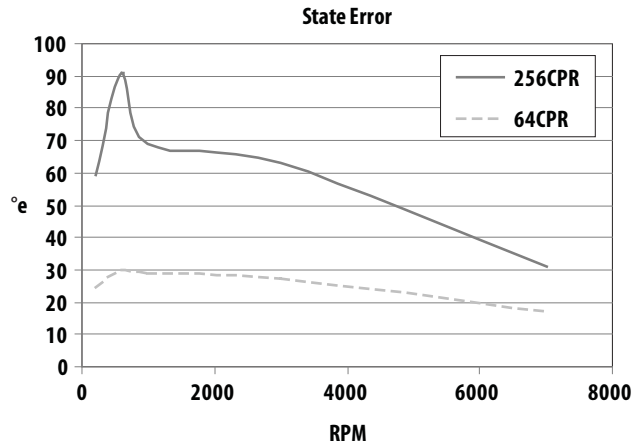

Table 4. Encoding Characteristics

Encoding Characteristics over Recommended Operating Range, typical at 25 °C over speed range.

Parameter	Symbol	Typ.	Units
Index Pulse Width	Po	150	°e

Package Dimensions

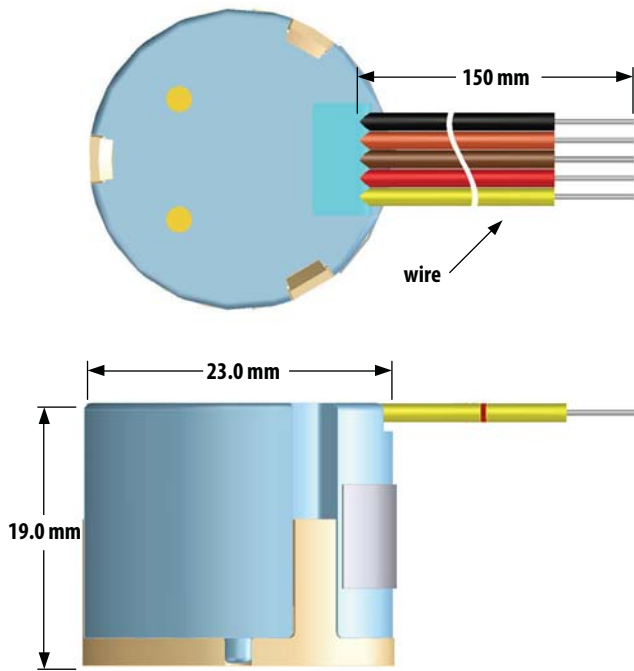
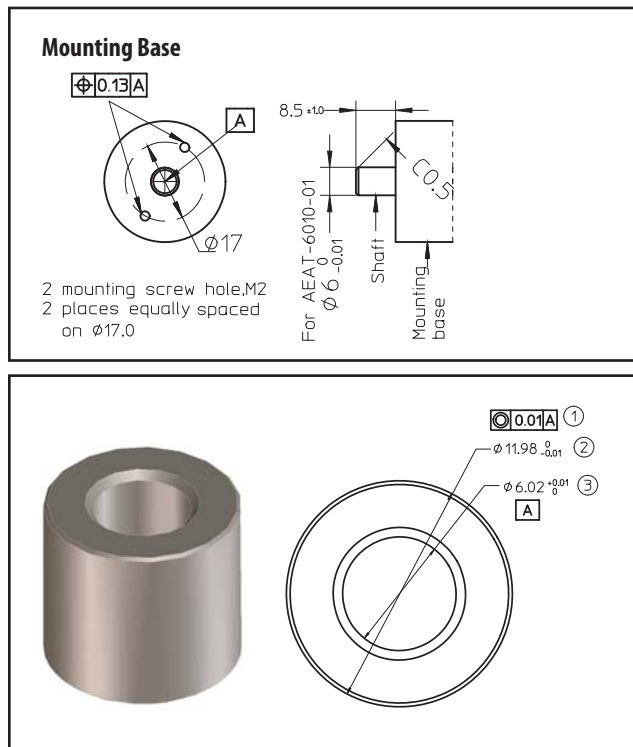

Figure 1. Package and recommended mounting dimension

Mounting Consideration

#	Parameter	Unit	Values
1	Maximum Shaft Axial Play	mm *	± 0.08
2	Maximum Shaft TIR	mm *	0.05
3	Maximum Mechanical Speed	RPM	12,000
4	Shaft Diameter	mm	6 +0 / -0.01
5	Moment Inertia	g-cm ²	0.104
6	Shaft Length	mm	8.5 ± 1.0
7	Mounting Screw Size	mm	M2 x 0.4 x 8 (socket head cap screw, head Ø3.8 ± 0.18mm)
8	Recommended screw torque	lb.inch	0.6
9	Encoder base plate thickness	mm	2
10	Bolt Circle	mm *	± 0.13

* Recommended to follow these limits for optimum performance



Optional - Centering Jig
(Refer to Application Note for details)

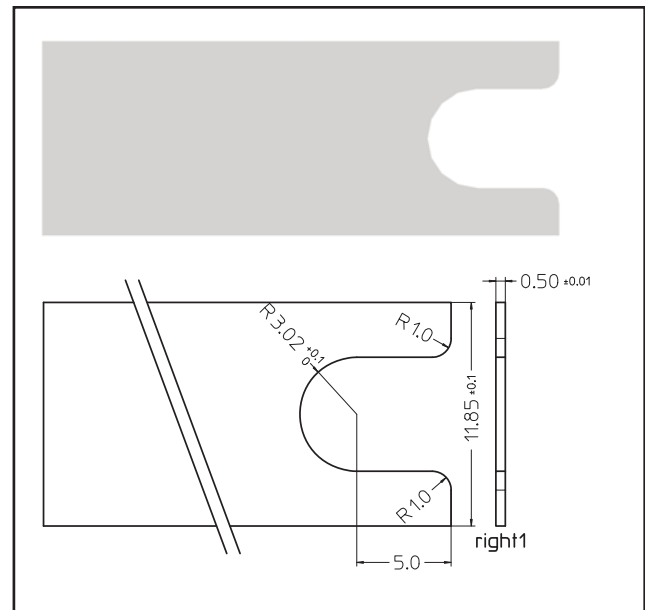

Optional - Base Gap Setting Plate
(Refer to Application Note for details)

Figure 2. Accessories - HEDS-8934, A set of optional centering and gap setting jigs (available for purchase separately)

Output Waveform

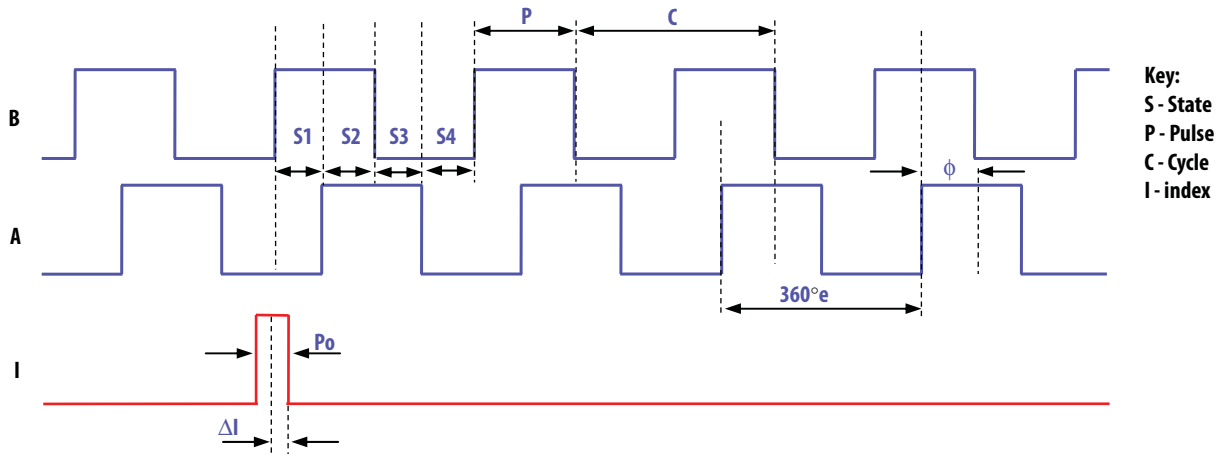

Note: Channel-B leads Channel-A at 90 °e at clockwise direction (top view of the encoder) and Channel-A leads Channel-B at 90 °e at anti-clockwise direction.

Figure 3. Incremental output waveform

Electrical Connections

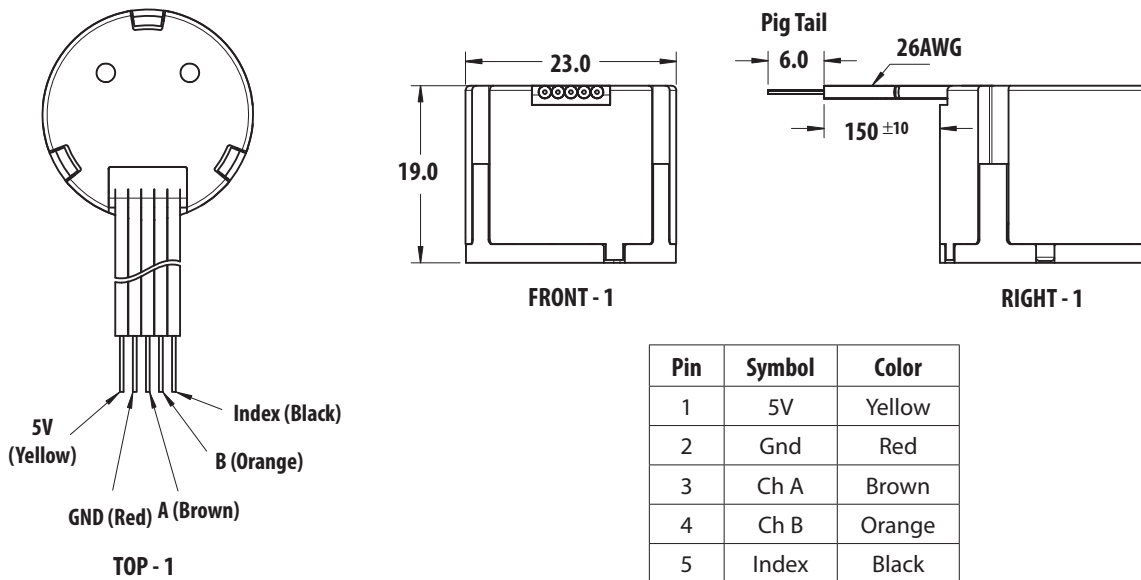

Figure 4. Electrical Connections

Ordering Information:

AEAT-601B-F06 256CPR, 3 Channel Incremental, 6mm Hub Size

HEDS-8934 Alignment tools set

Note: Resolution options of 32,64 and 128CPR is also available.
 Contact factory for these options.

For product information and a complete list of distributors, please go to our web site: www.avagotech.com

Avago, Avago Technologies, and the A logo are trademarks of Avago Technologies in the United States and other countries.
 Data subject to change. Copyright © 2005-2009 Avago Technologies. All rights reserved.
 AV02-2176EN - December 15, 2009

AVAGO
 TECHNOLOGIES

X-ON Electronics

Largest Supplier of Electrical and Electronic Components

Click to view similar products for [Encoders](#) category:

Click to view products by [Broadcom](#) manufacturer:

Other Similar products are found below :

[6-1393048-0](#) [6-1393048-5](#) [62AG22-H5-P](#) [62B22-LP-030C](#) [63K25](#) [63K32](#) [63KS100](#) [63KS64](#) [63R100](#) [63R50-020](#) [63RS256-060](#) [700-09-36](#)
[RE12D300-201-1](#) [1393047-3](#) [2-1393047-2](#) [T101-5C2-111-M1](#) [T101-5C3-111-M1](#) [T101-5C4-111-M1](#) [385001M0439](#) [385001M0216](#)
[V23401H1409B101](#) [V23401T8002B802](#) [V23401U6019B609](#) [E69-1](#) [E69DF10](#) [E69-FCA](#) [62B11-LP-100S](#) [62B11-LPP-040C](#) [62N11-P](#)
[62S22-H9-120S](#) [62S30-L0-200C](#) [62V15-02-080S](#) [63K64](#) [63KS100-040](#) [63R64-050](#) [63RS64](#) [700-16-16](#) [V23401D3002B301](#) [3-1393048-1](#)
[63KS128](#) [63KS256](#) [1-1879391-5](#) [GH65C11-N-SO](#) [62S15-M0-P](#) [1393047-1](#) [E69-FCA02](#) [E69-FCA04](#) [E69-DF20](#) [E69-DF2](#) [63R50](#)