

Data Sheet

Description

These line drivers are similar to the popular 26LS31 device, but without the enable function. They provide the additional supply voltage range necessary for use in many industrial control applications. AEIC-2631-S16 not only supports RS-422A, but use of supplies up to 30 V. Output voltage swings up to $V_{CC} - 2\text{ V}$ are typical. The outputs are protected against shorts to ground by a two-fold scheme of current limiting and thermal shutdown.

Thermal shutdown is accomplished by monitoring junction temperature and comparing this to a band gap reference on chip. Input hysteresis of about 0.5 V provides good noise margin, even in noisy industrial control environments. Input to output propagation delays of less than 200 ns are typical for rising and falling edges of the input waveform, measured to the zero crossing of the differential outputs.

This part is available in 16L SOIC (Pb-free) package.

Applications

- Encoders
- Industrial controls

Features

- Supply Voltage Range 4.75 V to 30 V
- Operation to 800 KHz
- CMOS and TTL Compatible Inputs
- Support RS422A
- High Impedance Buffered Inputs with hysteresis
- Outputs short circuit protected
- 70 mA peak SINK current
- Outputs Protected by Thermal Shut-Down

Pin Assignment

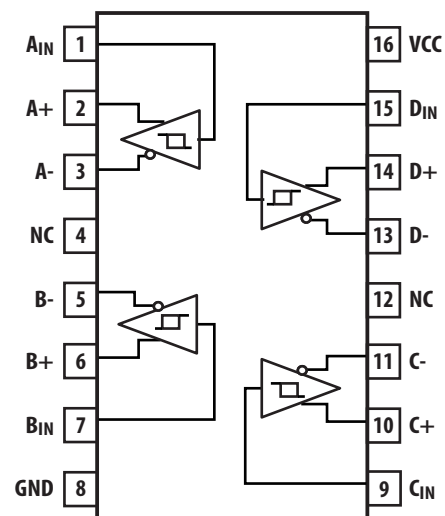

* Pin compatible with 26LS31 in applications which do not require an enable function.

Table 1. Absolute Maximum Ratings

Parameters	Symbol	Min.	Max.	Units	Ref.
Operating Temperature Range	T _A	-55	125	°C	
Supply Voltage Range	V _{CCD}	4.75	30	V	

Table 2. Electrical Characteristics

Unless otherwise specified, typical values given at V_{CC} = 2 V, T_A = 25° C and EN- < 0.8 V

Parameters	Symbol	Min.	Typ.	Max.	Units	Test Conditions
Overtemp Operate Point (junction)	T _{JOP}	-	155	-	°C	Note 1
Overtemp Release Point (junction)	T _{JRP}	-	105	-	°C	Note 1
Supply Current	I _{CC1}	7.0	11.0	17.0	mA	V _{CC} = 5 V (I _{CC1})
	I _{CC2}	9.0	13.0	20.0		V _{CC} = 30 V (I _{CC2})
Input Positive-Going Threshold	V _{T+}	1.1	1.5	1.9	V	
Input Negative-Going Threshold	V _{T-}	0.7	1.0	1.4	V	
Low Level Input Current	I _{IL}	-4.0	-0.13	-	μA	V _{IN} = 0 V, V _{CC} = 30 V
High Level Input Current	I _{IH}	-	0	4.0	μA	V _{IN} = 30 V, V _{CC} = 30 V
Low Level Output1	V _{OL1}	-	375	500	mV	I _{OL} = 20 mA, V _{CC} = 5 V
Low Level Output2	V _{OL2}	-	375	500	mV	I _{OL} = 20 mA, V _{CC} = 30 V
High Level Output1	V _{OH1}	2.5	2.8	-	V	I _{OH} = -20 mA, V _{CC} = 5 V
High Level Output2	V _{OH2}	27.8	28.0	-	V	I _{OH} = -20 mA, V _{CC} = 30 V

Notes :

1. This is not a test parameter, but for information only.
2. It may be necessary to clamp the outputs with Schottky diodes when driving extremely long cables with high capacitance between outputs. These diodes should have a forward voltage of less than 0.4 V, and be connected with cathode to the output and anode to ground.

Table 3. AC Switching Characteristics

Values given at V_{CC} = 24 V, T_A = 25° C, C_L = 100 pF on all outputs.

Parameters	Symbol	Min.	Typ.	Max.	Units	Test Conditions
Propagation delay, rising input 50% point to zero crossing of differential outputs	T _{PLH}	-	150	285	ns	See above.
Propagation delay, falling input 50% point to zero crossing of differential outputs	T _{PHL}	-	170	310	ns	See above.
Output Rise Time	T _R	-	95	310	ns	See above.
Output Fall Time	T _F	-	40	165	ns	See above.

Package Drawings (Dimensions in Inches)

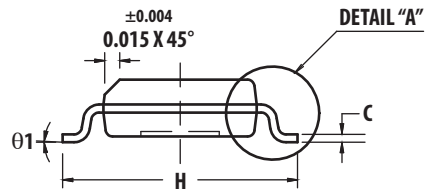
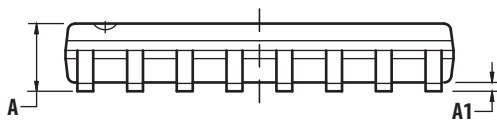
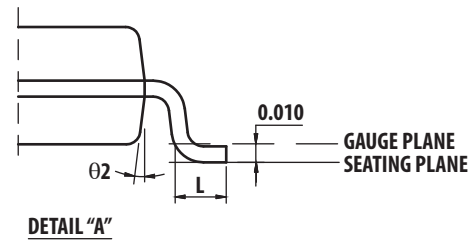
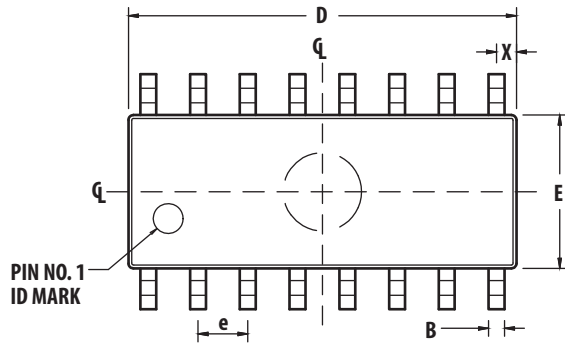

Symbol	16 SOIC	
	Min	Max
A	0.054	0.068
A1	0.004	0.0098
B	0.014	0.019
D	0.386	0.393
E	0.150	0.157
H	0.229	0.244
e	0.050 BSC	
C	0.0075	0.0098
L	0.016	0.034
X	0.020 REF	
theta 1	0°	8°
theta 2	7° BSC	

Notes:

1. Lead coplanarity should be 0 to 0.004" max.
2. Package surface finishing: VD1 24~27 (Dual).
Package surface finishing: VD1 13~15 (16L Soic(NB) Matrix).
3. All dimension excluding mold flashes.
4. The lead width, B to be determined at 0.0075" from the lead tip.

For product information and a complete list of distributors, please go to our web site: www.avagotech.com

Avago, Avago Technologies, and the A logo are trademarks of Avago Technologies in the United States and other countries.
Data subject to change. Copyright © 2005-2011 Avago Technologies. All rights reserved.
AV02-3023EN - September 7, 2011

AVAGO
TECHNOLOGIES

X-ON Electronics

Largest Supplier of Electrical and Electronic Components

Click to view similar products for [Buffers & Line Drivers](#) category:

Click to view products by [Broadcom](#) manufacturer:

Other Similar products are found below :

[LXV200-024SW](#) [74AUP2G34FW3-7](#) [HEF4043BP](#) [NLU1GT126CMUTCG](#) [PI74FCT3244L](#) [MC74HCT365ADTR2G](#) [Le87401NQC](#)
[Le87402MQC](#) [028192B](#) [042140C](#) [051117G](#) [070519XB](#) [NL17SZ07P5T5G](#) [NLU1GT126AMUTCG](#) [74AUP1G17FW5-7](#) [74LVC2G17FW4-7](#)
[CD4502BE](#) [5962-8982101PA](#) [5962-9052201PA](#) [74LVC1G125FW4-7](#) [NL17SH17P5T5G](#) [74HCT126T14-13](#) [NL17SH125P5T5G](#)
[NLV37WZ07USG](#) [RHRXH162244K1](#) [74AUP1G34FW5-7](#) [74AUP1G07FW5-7](#) [74LVC2G126RA3-7](#) [NLX2G17CMUTCG](#)
[74LVCE1G125FZ4-7](#) [Le87501NQC](#) [74AUP1G126FW5-7](#) [TC74HC4050AP\(F\)](#) [74LVCE1G07FZ4-7](#) [NLX3G16DMUTCG](#)
[NLX2G06AMUTCG](#) [NLU2G17AMUTCG](#) [LE87100NQC](#) [LE87100NQCT](#) [LE87285NQC](#) [LE87285NQCT](#) [LE87290YQC](#) [LE87290YQCT](#)
[LE87511NQC](#) [LE87511NQCT](#) [LE87557NQC](#) [LE87557NQCT](#) [LE87614MQC](#) [LE87614MQCT](#) [LE87286NQCT](#)