

## AEMD-LM3L, AEMD-LB3L

### High Brightness Green and Blue SMT Oval Lamps

---

#### Description

The new Broadcom<sup>®</sup> series is essentially like a conventional high brightness through hole LED in the form of a surface mount device. It can be assembled using common SMT assembly processes and is compatible with the industrial reflow soldering process.

The LEDs are made with an advanced optical grade epoxy for superior performance in outdoor sign applications. For easy pick-and-place assembly, the LEDs are shipped in tape and reel. Every reel is shipped from a single intensity and color bin for better uniformity.

#### Features

- High brightness InGaN
- Available in Green and Blue
- Typical viewing angle: 100° × 45°
- Tinted appearance
- Surface mountable
- Compatible with industrial reflow soldering process
- MSL 3

#### Applications

- Gas price signs
- Monocolor signs
- Full color signs

**CAUTION!** This LED is ESD sensitive. Please observe appropriate precautions during handling and processing. Refer to application note AN-1142 for additional details.

Keep the LED in a moisture barrier bag is < 5% RH when not in use because prolonged exposure to the environment might cause the leads to tarnish or rust, which might cause difficulties in soldering.

Figure 1: Package Drawing

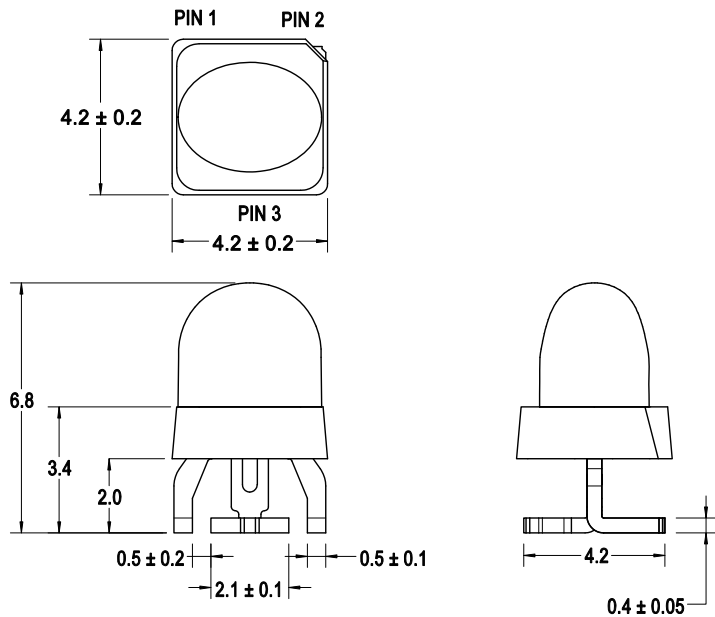

Lead Configuration	
Pin 1	Anode
Pin 2	Cathode
Pin 3	Anode

**NOTE:**

1. All dimensions in millimeters (mm).
2. Tolerance is  $\pm 0.50$  mm unless otherwise specified.

## Device Selection Guide

$T_J = 25^\circ\text{C}$ ,  $I_F = 20$  mA.

Part Number	Color	Luminous Intensity, $I_V$ (mcd) <sup>a, b</sup>		Dominant Wavelength, $\lambda_d$ (nm) <sup>c</sup>	
		Min.	Max.	Min.	Max.
AEMD-LM3L-35002	Green	4200	7260	519	539
AEMD-LM3L-45B02	Green	5040	7260	523	531
AEMD-LM3L-45C02	Green	5040	7260	527	535
AEMD-LB3L-UW002	Blue	960	1660	460	480
AEMD-LB3L-UVB02	Blue	960	1380	464	472
AEMD-LB3L-UVC02	Blue	960	1380	468	476

- a. The luminous intensity,  $I_V$  is measured at the mechanical axis of the package and it is tested with a single current pulse condition. The actual peak of the spatial radiation pattern may not be aligned with the axis.
- b. Tolerance is  $\pm 15\%$ .
- c. The dominant wavelength,  $\lambda_d$  is derived from the CIE Chromaticity Diagram and represents the perceived color of the device.

## Absolute Maximum Ratings

Parameters	Green	Blue	Units
DC Forward Current <sup>a</sup>	30	20	mA
Peak Forward Current <sup>b</sup>	100	100	mA
Power Dissipation	114	76	mW
Reverse Voltage	Not recommended for reverse bias		
LED Junction Temperature	110		°C
Operating Temperature Range	-40 to +85		°C
Storage Temperature Range	-40 to +100		°C

a. Derate linearly as shown in [Figure 9](#).

b. Duty factor = 10%, frequency = 1 kHz.

## Optical and Electrical Characteristics

$T_J = 25^\circ\text{C}$ .

Parameters	Min.	Typ.	Max.	Units	Test Condition
Viewing Angle, $2\theta_{1/2}$ <sup>a</sup>	—	100 × 45	—	°	$I_F = 20\text{ mA}$
Dominant Wavelength, $\lambda_d$ <sup>b</sup>				nm	$I_F = 20\text{ mA}$
Green	519.0	528.0	539.0		
Blue	460.0	470.0	480.0		
Peak Wavelength, $\lambda_p$				nm	$I_F = 20\text{ mA}$
Green	—	521.0	—		
Blue	—	466.0	—		
Forward Voltage, $V_F$ <sup>c</sup>				V	$I_F = 20\text{ mA}$
Green	—	2.8	3.8		
Blue	—	2.8	3.8		
Reverse Voltage, $V_R$ <sup>d</sup>				V	$I_R = 100\ \mu\text{A}$
Green	5	—	—		
Blue	5	—	—		
Thermal Resistance, $R\theta_{J-P}$ <sup>e</sup>				°C/W	LED junction to pin
Green	—	270	—		
Blue	—	480	—		

a.  $\theta_{1/2}$  is the off-axis angle where the luminous intensity is  $1/2$  the peak intensity.

b. The dominant wavelength,  $\lambda_d$  is derived from the CIE Chromaticity Diagram and represents the perceived color of the device.

c. Forward voltage tolerance is  $\pm 0.1\text{V}$ .

d. Indicates product final test condition. Long-term reverse bias is not recommended.

e. Thermal resistance from LED junction to pin.

## Part Numbering System

A E M D - 

x <sub>1</sub>	x <sub>2</sub>	x <sub>3</sub>
----------------	----------------	----------------

 L - 

x <sub>4</sub>	x <sub>5</sub>	x <sub>6</sub>	x <sub>7</sub>	x <sub>8</sub>
----------------	----------------	----------------	----------------	----------------

Code	Description	Option	
x <sub>1</sub>	Package Type	L	Oval InGaN
x <sub>2</sub>	Color	B	Blue
		M	Green
x <sub>3</sub>	Viewing Angle	3	Typical 100° × 45°
x <sub>4</sub>	Minimum Intensity Bin	Refer to <a href="#">Intensity Bin Limits (CAT)</a> table	
x <sub>5</sub>	Maximum Intensity Bin		
x <sub>6</sub>	Color Bin Option	0	Full distribution
		B	Bins 2 and 3
		C	Bins 3 and 4
x <sub>7</sub> x <sub>8</sub>	Packaging Option	02	Tested at 20 mA

## Part Number Example

AEMD-LM3L-45C02

x<sub>1</sub> : L            –    Oval InGaN  
 x<sub>2</sub> : M            –    Green color  
 x<sub>3</sub> : 3            –    Typical 100° × 45°  
 x<sub>4</sub> : 4            –    Minimum intensity bin 4  
 x<sub>5</sub> : 5            –    Maximum intensity bin 5  
 x<sub>6</sub> : C            –    Color bins 3 and 4  
 x<sub>7</sub> x<sub>8</sub> : 02        –    Tested at 20 mA

## Bin Information

### Intensity Bin Limits (CAT)

Bin ID	Luminous Intensity, $I_v$ (mcd)	
	Min.	Max.
<b>Green</b>		
3	4200	5040
4	5040	6050
5	6050	7260
<b>Blue</b>		
U	960	1150
V	1150	1380
W	1380	1660

Tolerance =  $\pm 15\%$

### Color Bin Limits (BIN)

Bin ID	Dominant Wavelength, $\lambda_d$ (nm)	
	Min.	Max.
<b>Green</b>		
1	519	523
2	523	527
3	527	531
4	531	535
5	535	539
<b>Blue</b>		
1	460	464
2	464	468
3	568	472
4	472	476
5	476	480

Tolerance =  $\pm 1.0$  nm

Example of bin information on reel and packaging label:

CAT : 3 – Intensity bin 3

BIN : 2 – Color bin 2

Figure 2: Spectral Power Distribution

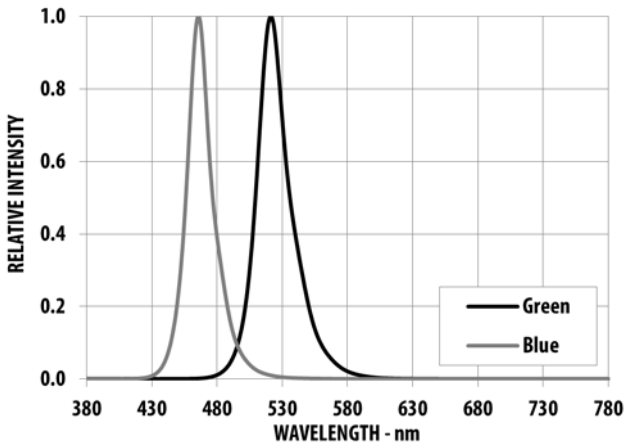

Figure 3: Forward Current vs. Forward Voltage

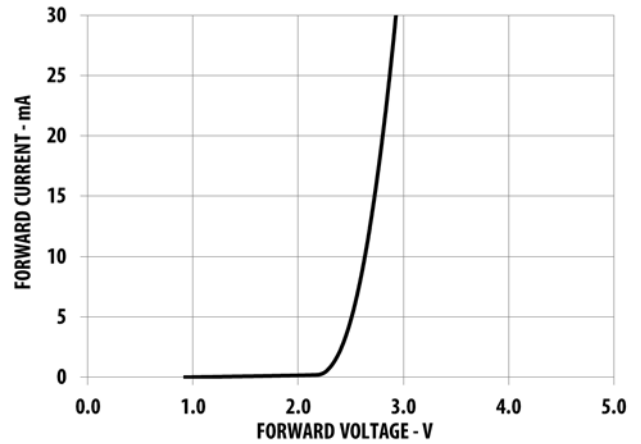

Figure 4: Relative Luminous Intensity vs. Mono Pulse Current

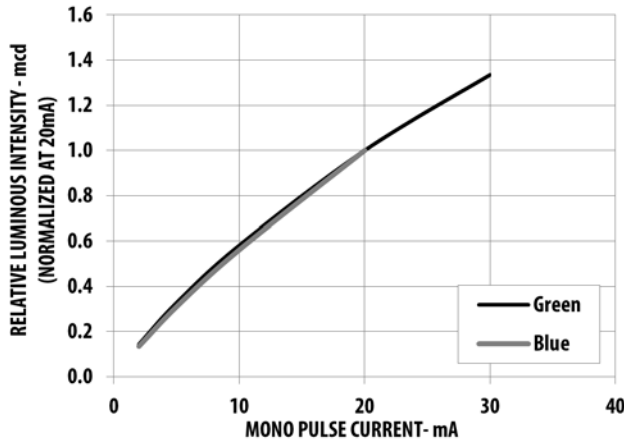

Figure 5: Dominant Wavelength Shift vs. Mono Pulse Current

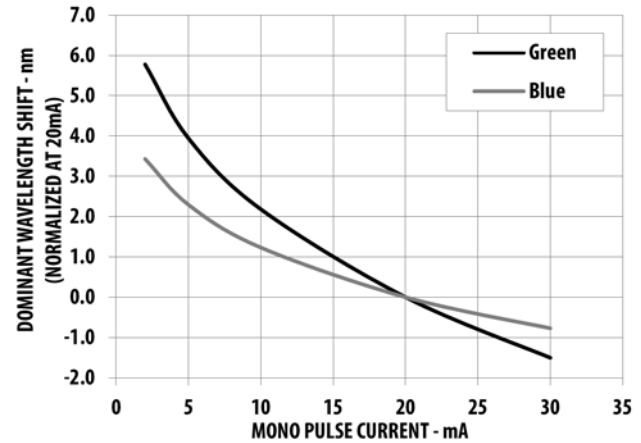

Figure 6: Relative Light Output vs. Junction Temperature

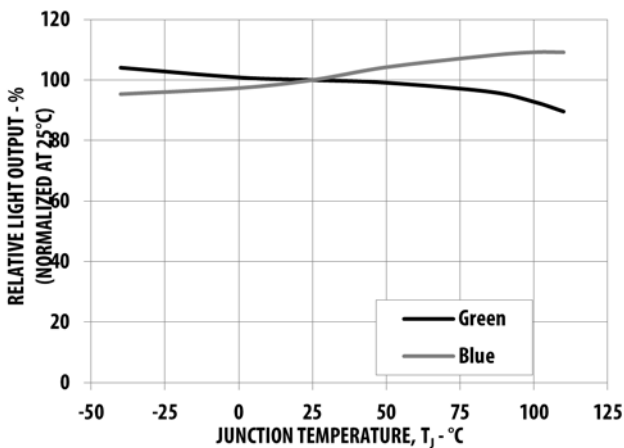

Figure 7: Forward Voltage Shift vs. Junction Temperature

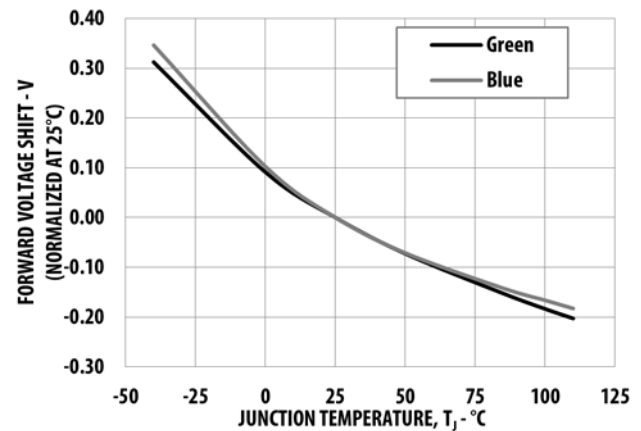

Figure 8: Radiation Pattern

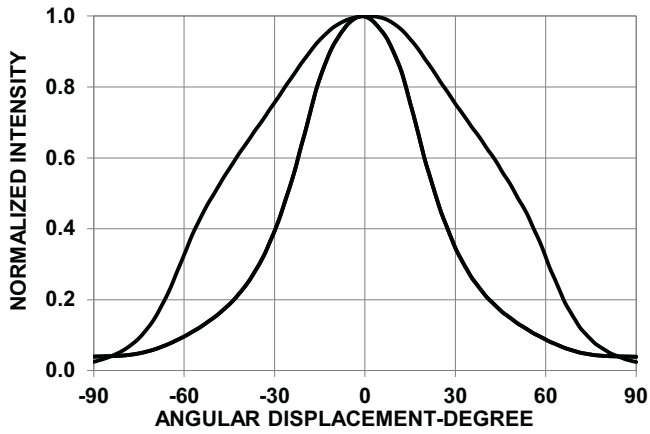

Figure 9: Maximum Forward Current vs. Ambient Temperature. Derated based on  $T_{JMAX} = 110^{\circ}C$

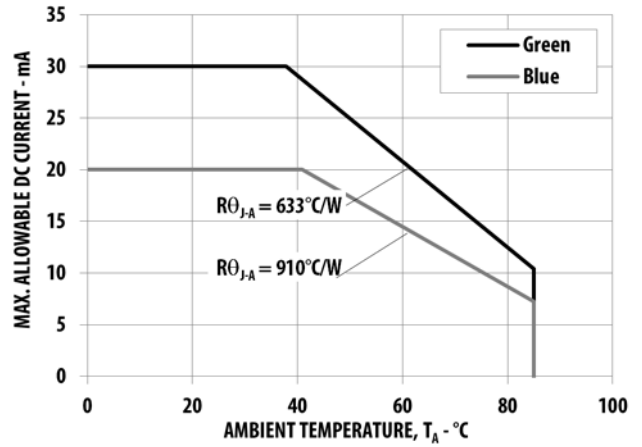
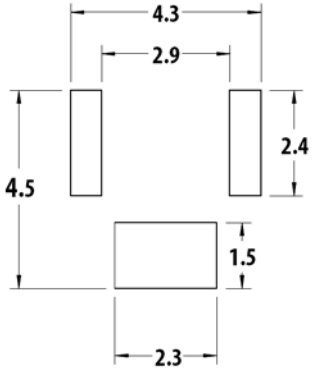

Figure 10: Recommended Soldering Land Pattern



**NOTE:**

1. All dimensions are in millimeters (mm).
2. Recommended stencil thickness is 0.1524 mm (6 mil) minimum and above.

Figure 11: Carrier Tape Dimensions

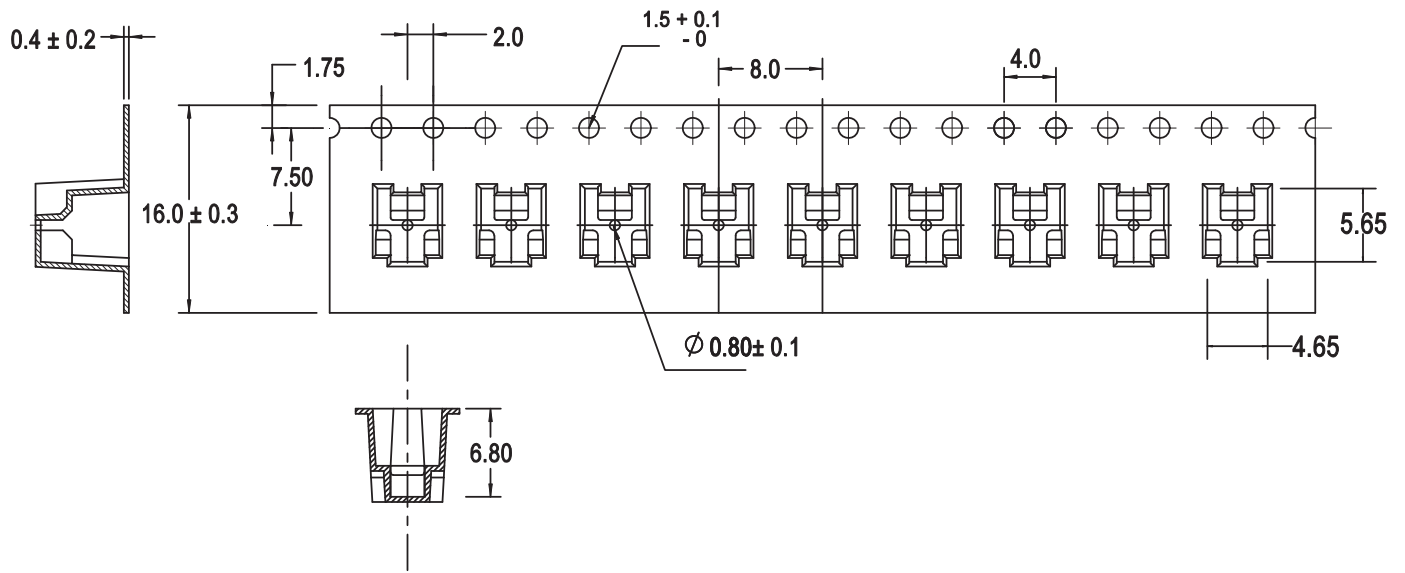

**NOTE:**

1. All dimensions in millimeters (mm).
2. Tolerance is  $\pm 0.10$  mm unless otherwise specified.

Figure 12: Reel Dimensions

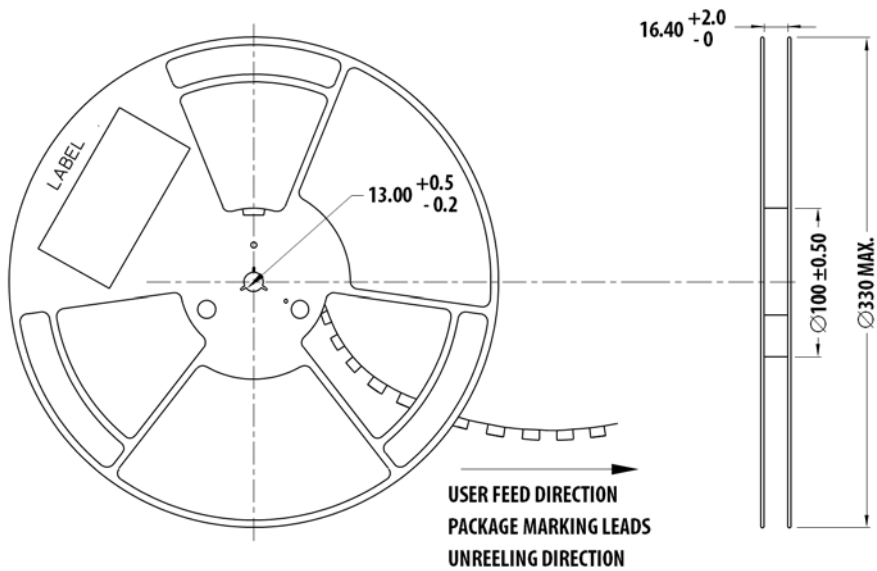

**NOTE:** All dimensions are in millimeters (mm).



# Precautionary Notes

## Soldering

- Do not perform reflow soldering more than twice. Observe necessary precautions of handling moisture-sensitive devices as stated in the following section.
- Do not apply any pressure or force on the LED during reflow and after reflow when the LED is still hot.
- Use reflow soldering to solder the LED. Use hand soldering only for rework if unavoidable, but it must be strictly controlled to following conditions:
  - Soldering iron tip temperature = 315°C maximum.
  - Soldering duration = 3 seconds maximum.
  - Number of cycles = 1 only.
  - Power of soldering iron = 50W maximum.
- Do not touch the LED package body with the soldering iron except for the soldering terminals, as it may cause damage to the LED.
- Confirm beforehand whether the functionality and performance of the LED is affected by soldering with hand soldering.

Figure 13: Recommended Lead-Free Reflow Soldering Profile

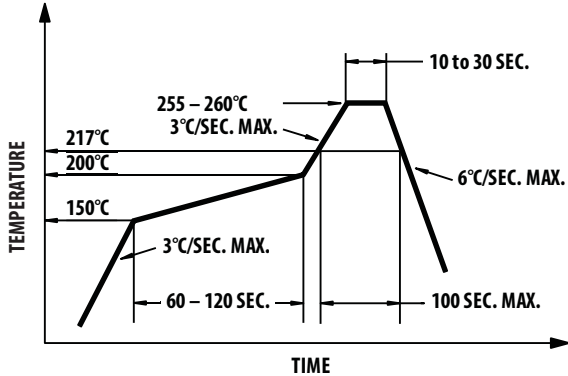

## Handling Precautions

For automated pick-and-place, Broadcom has tested the following nozzle size to work well with this LED. However, due to the possibility of variations in other parameters, such as pick-and-place machine maker/model, and other settings of the machine, verify that the selected nozzle performs as per requirements.

Figure 14: Recommended Nozzle Dimension

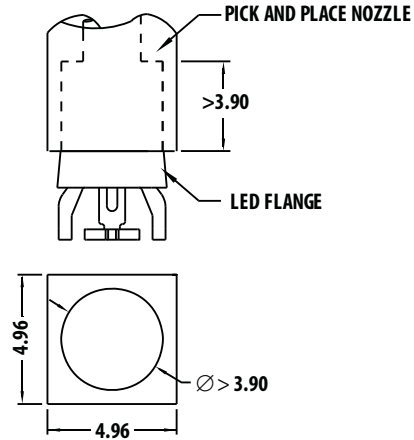

**NOTE:**

1. The nozzle tip must touch the LED flange during pick and place.
2. The outer dimensions of the nozzle tip must be able to fit into the carrier tape pocket until it touches the LED flange.
3. All dimensions are in millimeters (mm).

## Handling of Moisture-Sensitive Devices

This product has a Moisture Sensitive Level 3 rating per JEDEC J-STD-020. Refer to Broadcom Application Note AN5305, *Handling of Moisture Sensitive Surface Mount Devices*, for additional details and a review of proper handling procedures.

**Before use:**

- An unopened moisture barrier bag (MBB) can be stored at < 40°C/90% RH for 12 months. If the actual shelf life has exceeded 12 months and the humidity indicator card (HIC) indicates that baking is not required, it is safe to reflow the LEDs per the original MSL rating.
- Do not open the MBB prior to assembly (for example, for IQC). If unavoidable, the MBB must be properly resealed with fresh desiccant and HIC. The exposed duration must be taken in as floor life.

**Control after opening the MBB:**

- Read the HIC immediately upon opening of MBB.
- Keep the LEDs at < 30°/60% RH at all times, and complete all high temperature-related processes, including soldering, curing or rework within 168 hours.

**Control for unfinished reel:**

Store unused LEDs in a sealed MBB with desiccant or a desiccator at < 5% RH.

**Control of assembled boards:**

If the PCB soldered with the LEDs is to be subjected to other high-temperature processes, store the PCB in a sealed MBB with desiccant or desiccator at < 5% RH to ensure that all LEDs have not exceeded their floor life of 168 hours.

**Baking is required if the following conditions exist:**

- The HIC indicator indicates a change in color for 10% and 5%, as stated on the HIC.
- The LEDs are exposed to conditions of > 30°C/60% RH at any time.
- The LED's floor life exceeded 168 hours.

The recommended baking condition is: 60°C ± 5°C for 20 hours.

Baking can only be done once.

**Storage:**

The soldering terminals of these Broadcom LEDs are silver plated. If the LEDs are exposed in an ambient environment for too long, the silver plating might be oxidized, thus affecting its solderability performance. Therefore, keep unused LEDs in a sealed MBB with desiccant or in a desiccator at < 5% RH.

**Application Precautions**

- The drive current of the LED must not exceed the maximum allowable limit across temperature as stated in the data sheet. Constant current driving is recommended to ensure consistent performance.
- Circuit design must cater to the whole range of forward voltage ( $V_F$ ) of the LEDs to ensure the intended drive current can always be achieved.
- The LED exhibits slightly different characteristics at different drive currents, which may result in a larger variation of performance (such as intensity, wavelength,

and forward voltage). Set the application current as close as possible to the test current to minimize these variations.

- The LED is not intended for reverse bias. Use other appropriate components for such purposes. When driving the LED in matrix form, ensure that the reverse bias voltage does not exceed the allowable limit of the LED.
- As the actual application might not be exactly similar to the test conditions, verify that the LED will not be damaged by prolonged exposure in the intended environment.
- Avoid rapid changes in ambient temperatures, especially in high-humidity environments, because they cause condensation on the LED.
- If the LED is intended to be used in a harsh or an outdoor environment, protect the LED against damage caused by rain water, water, dust, oil, corrosive gases, external mechanical stresses, and so on.
- The number of reflow cycles and reflow temperature condition used may affect optical characteristics of the LED. Use LEDs with the same number of reflow cycle and same reflow temperature condition within the same finished good.

**Thermal Management**

The optical, electrical, and reliability characteristics of the LED are affected by temperature. Keep the junction temperature ( $T_J$ ) of the LED below the allowable limit at all times.  $T_J$  can be calculated as follows:

$$T_J = T_A + R_{\theta J-A} \times I_F \times V_{Fmax}$$

where:

$T_A$  = Ambient temperature (°C)

$R_{\theta J-A}$  = Thermal resistance from LED junction to ambient (°C/W)

$I_F$  = Forward current (A)

$V_{Fmax}$  = Maximum forward voltage (V)

The complication of using this formula lies in  $T_A$  and  $R_{\theta J-A}$ . Actual  $T_A$  is sometimes subjective and hard to determine.  $R_{\theta J-A}$  varies from system to system depending on design and is usually not known.

Another way of calculating  $T_J$  is by using the solder point temperature,  $T_S$  as follows:

$$T_J = T_S + R_{\theta J-S} \times I_F \times V_{Fmax}$$

where:

$T_S$  = LED solder point temperature as shown in the following figure ( $^{\circ}\text{C}$ )

$R_{\theta J-S}$  = Thermal resistance from junction to solder point ( $^{\circ}\text{C}/\text{W}$ )

$I_F$  = Forward current (A)

$V_{Fmax}$  = Maximum forward voltage (V)

**Figure 15: Solder Point Temperature on PCB**

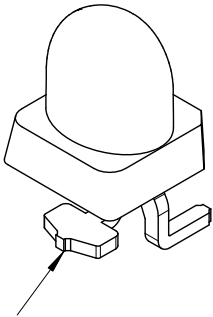

**Ts Point**

$T_S$  can be easily measured by mounting a thermocouple on the soldering joint as shown in preceding figure, while  $R_{\theta J-S}$  is provided in the data sheet. Verify the  $T_S$  of the LED in the final product to ensure that the LEDs are operating within all maximum ratings stated in the data sheet.

## Eye Safety Precautions

LEDs may pose optical hazards when in operation. Do not look directly at operating LEDs because it might be harmful to the eyes. For safety reasons, use appropriate shielding or personal protective equipment.

## Disclaimer

Broadcom's products and software are not specifically designed, manufactured, or authorized for sale as parts, components, or assemblies for the planning, construction, maintenance, or direct operation of a nuclear facility or for use in medical devices or applications. The customer is solely responsible, and waives all rights to make claims against Broadcom or its suppliers, for all loss, damage, expense, or liability in connection with such use.

Broadcom, the pulse logo, Connecting everything, Avago Technologies, Avago, and the A logo are among the trademarks of Broadcom and/or its affiliates in the United States, certain other countries, and/or the EU.

Copyright © 2018–2021 Broadcom. All Rights Reserved.

The term "Broadcom" refers to Broadcom Limited and/or its subsidiaries. For more information, please visit [www.broadcom.com](http://www.broadcom.com).

Broadcom reserves the right to make changes without further notice to any products or data herein to improve reliability, function, or design. Information furnished by Broadcom is believed to be accurate and reliable. However, Broadcom does not assume any liability arising out of the application or use of this information, nor the application or use of any product or circuit described herein, neither does it convey any license under its patent rights nor the rights of others.



## X-ON Electronics

Largest Supplier of Electrical and Electronic Components

*Click to view similar products for [Standard LEDs - SMD category](#):*

*Click to view products by [Broadcom manufacturer](#):*

Other Similar products are found below :

[LTST-C19GD2WT](#) [LTST-N683GBEW](#) [LTW-170ZDC](#) [LTW-M140SZS40](#) [598-8110-100F](#) [598-8170-100F](#) [598-8610-202F](#) [67-22VRVGC/TR8](#) [AAAF5060QBFSEEZGS](#) [HLMA-QG00-S0021](#) [HLMP-6305-L0011](#) [ALMD-LB36-SV002](#) [APT1608QGW](#) [15-21UYC/S530-A3/TR8](#) [EASV1803BA0](#) [LG M67K-H1J2-24-0-2-R18-Z](#) [LS A676-P2S1-1](#) [SML-512VWT86A](#) [SML-LX0606SISUGC/A](#) [SML-LXL1307SRC-TR](#) [SML-LXR851SIUPGUBC](#) [LT1ED53A](#) [FAT801-S](#) [AM27ZGC03](#) [APB3025SGNC](#) [APFA3010SURKCGKQBDC](#) [APHK1608VGCA](#) [APT2012QGW](#) [CLX6D-FKB-CN1R1H1BB7D3D3](#) [LTST-C250KGKT](#) [LTW-020ZDCG](#) [LTW-21TS5](#) [LTW-220DS5](#) [JANTXM19500/521-02](#) [UYGT801-S](#) [42-21UYC/S530-A3/TR8](#) [LO T67F-V1AB-24-1](#) [YGFR411-H](#) [SML-LX0402IC-TR](#) [CMDA20AYAA7D1S](#) [CMDA16AYDR7A1X](#) [339-1SURSYGW/S530-A2](#) [598-8040-100F](#) [598-8070-100F](#) [598-8140-100F](#) [598-8610-200F](#) [EAPL3527GA5](#) [SML-LXL1209SYC/ATR](#) [EASV3020YGA0](#) [EAST16086YA5](#)