

# AFBR-2CARxxZ

## 10G Ethernet SFP+ Active Optical Cable (AOC)



### Product Brief



#### Description

The Avago Technologies' AFBR-2CARxxZ Active Optical Cable (AOC) is part of a family of SFP+ products to serve 10Gb Ethernet (10GbE) applications. The letters "xx" of the part number AFBR-2CARxxZ denote the cable length in meters. The AFBR-2CARxxZ AOC enables 10GbE equipment designs with very high port density based on the electrical and mechanical specification enhancements to the well known SFP specifications developed by the SFF Committee. The specifications are referred to as "SFP+" to represent the enhancements over previous SFP specifications. The SFP+ AOC have a cable length up to 20m. These AOCs can be used as an alternative solution to SFP+ passive and active copper cables, while providing improved signal integrity, longer distances, superior electromagnetic immunity and better bit error rate performance.

#### Part Numbers

AFBR-2CAR01Z	1 meter SFP+ Active Optical Cable
AFBR-2CAR02Z	2 meter SFP+ Active Optical Cable
AFBR-2CAR03Z	3 meter SFP+ Active Optical Cable
AFBR-2CAR05Z	5 meter SFP+ Active Optical Cable
AFBR-2CAR07Z	7 meter SFP+ Active Optical Cable
AFBR-2CAR10Z	10 meter SFP+ Active Optical Cable
AFBR-2CAR15Z	15 meter SFP+ Active Optical Cable
AFBR-2CAR20Z	20 meter SFP+ Active Optical Cable
AFCT-5016Z	SFP+ Evaluation Board

#### Features

- Proven High Reliability 850 nm technology: Avago VCSEL transmitter and Avago PIN receiver
- Maximum power dissipation 350 mW per Active Cable end
- Avago SFP+ package design enables equipment EMI performance in high port density applications with margin to Class B limits

#### Specifications

- Electrical specifications per SFF-8431 Specifications for Enhanced Small Form Factor Pluggable Module SFP+
- 0 to 70 °C case temperature operating range
- Rx\_LOS and Tx\_DISABLE supported
- Mechanical specifications per SFF Committee SFF 8432 Improved Pluggable Formfactor "IPF"
- Compliant to Restriction on Hazardous Substances (RoHS) per EU and China requirements
- Class 1 eye safe per requirement of EN 60825-1 2007, EN 60825-2 A2 2010
- 1E-15 BER performance

#### Applications

- 1/10 Gigabit Ethernet (1/10GbE)
- 1/2/4/8G Fibre Channel (1/2/4/8GFC), Fibre Channel
- InfiniBand (QDR/DDR/SDR)
- Data Center Networking
  - Converged Enhanced Ethernet Data Centers
  - Data Center Bridging
- Networked storage systems
- High Performance Computing
- Proprietary Interconnects

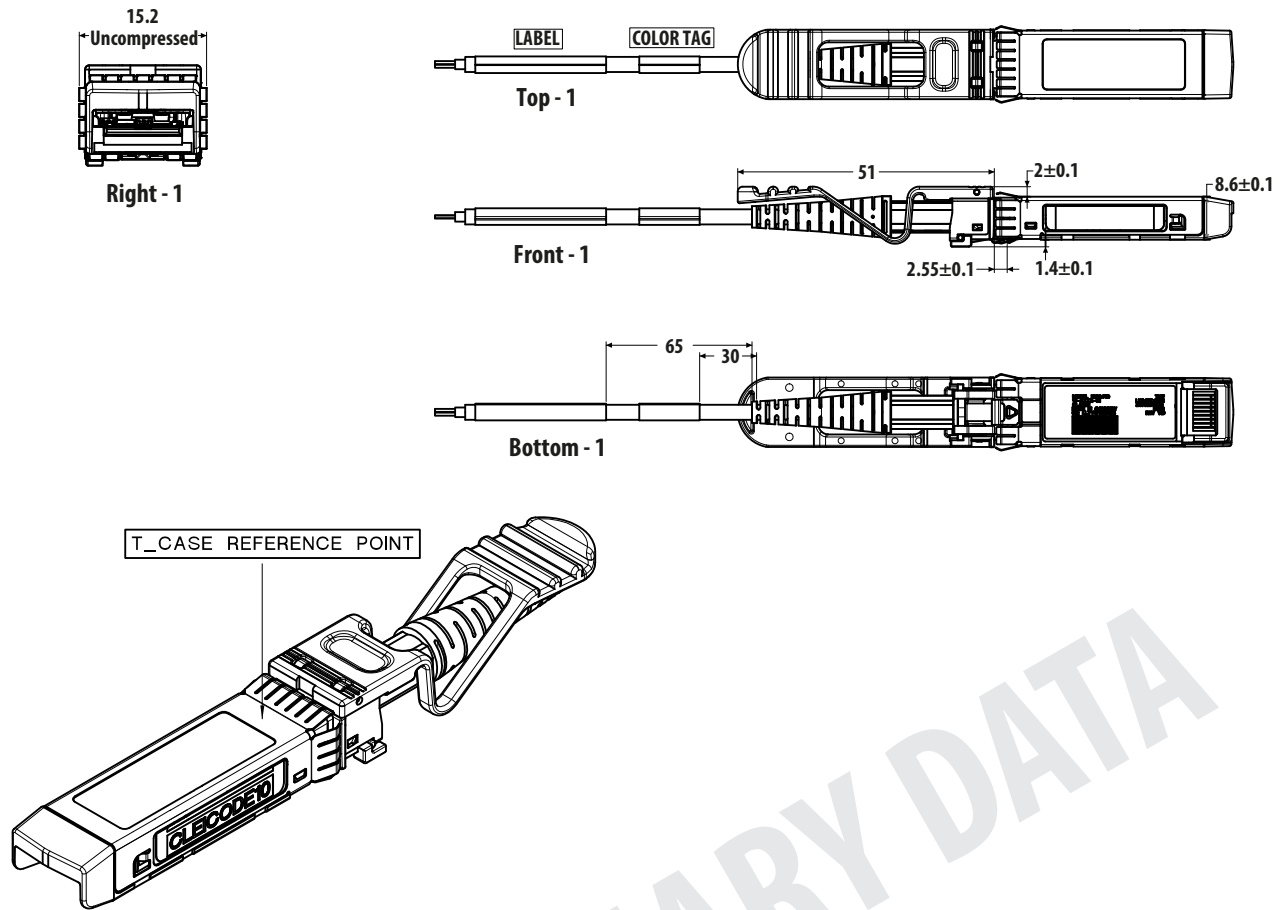

### Key Parameters

Parameter	Value	Units	Notes
Data rate per lane	From 1 to 10.3125	Gbps	No retimer or CDR devices embedded in the module. Allows operation at datarates below 10.3125 Gbps
Protocols	1 GbE, 10GbE 1/2/4/8/10 GFC SDR/DDR QDR		Ethernet, Fibre Channel, InfiniBand, Other Protocols and Proprietary Datarates as well
Power Supply Voltage	3.3	V	± 5%
Temperature Range	0 - 70	°C	
Wavelength	850	nm	
Bit Error Rate Performance	1E-15		
Management Interface	Two-Wire Serial		Memory Map access Page A0h only per SFF-8472 Revision 11.0
Laser Output Power	Class 1		EN 60825-1 2007, EN 60825-2 A2 2010
Power consumption per end	275	mW	Nominal Power
Mechanical Specification			Mechanical specifications per SFF Committee SFF-8432 Improved Pluggable Formfactor "IPF" Can be installed in any INF-8074 or SFF-8431/2 compliant Small Form Pluggable (SFP) port
Electrical Interface	20	pins	SFF Committee SFF 8431 Specifications for Enhanced 8.5 and 10 Gigabit Small Form Factor Pluggable Module "SFP+"

For product information and a complete list of distributors, please go to our website: [www.avagotech.com](http://www.avagotech.com)

Avago, Avago Technologies, and the A logo are trademarks of Avago Technologies in the United States and other countries. Data subject to change. Copyright © 2005-2014 Avago Technologies. All rights reserved. AV02-4473EN - March 21, 2014

**Avago**  
TECHNOLOGIES

## X-ON Electronics

Largest Supplier of Electrical and Electronic Components

*Click to view similar products for* [Fibre Optic Transmitters, Receivers, Transceivers](#) *category:*

*Click to view products by* [Broadcom](#) *manufacturer:*

Other Similar products are found below :

[STV.2413-574-00262](#) [TRPRG1VA1C000E2G](#) [TOTX1350\(V,F\)](#) [FTLX3813M349](#) [SCN-1428SC](#) [LTK-ST11MB](#) [HFD8003-002/XBA](#)  
[HFD3020-500-ABA](#) [FTLF1429P3BCVA](#) [S6846](#) [SCN-2638SC](#) [FTL410QE4N](#) [FTLC9555FEPM](#) [TQS-QG4H9-J83](#) [SCN-1570SC](#) [SCN-](#)  
[1601SC](#) [SCN-1338SC](#) [SFPPT-SR3-01](#) [HFD8003-500-XBA](#) [SCN-1383SC](#) [2333569-1](#) [LNK-ST11HB-R6](#) [FTL4C1QL3L](#) [FTL4C1QE3L](#)  
[FTL4C1QL3C](#) [SPTSHP3PMCDF](#) [SPTSBP4LLCDF](#) [SPTMBP1PMCDF](#) [SPTSHP2PMCDF](#) [SF-NLNAMB0001](#) [SPTSHP2SLCDF](#)  
[SPTSQP4LLCDF](#) [1019682](#) [1019683](#) [1019705](#) [HFBR-1415Z](#) [AFBR-5803ATQZ](#) [AFBR-5803ATZ](#) [PLR135/T9](#) [TGW-Q14BB-FCQ](#) [AFBR-](#)  
[5803AZ](#) [TQS-Q1LH8-XCA03](#) [TQS-Q1LH8-XCA05](#) [TQS-Q1LH8-XCA10](#) [TQS-Q1LH9-2CA](#) [HFBR-1414Z](#) [HFBR-1527Z](#) [HFBR-1528Z](#)  
[HFBR-2406Z](#) [HFBR-2505AZ](#)