

# AFCT-5760xNxZ and AFCT-5765xNxZ

Families of Small Form Factor Pluggable (SFP) Optical Transceivers for Single-Mode OC3/STM-1 with Optional DMI  
Part of the Avago Technologies METRAK Family



## Data Sheet



### Description

The AFCT-576xZ family of SFP optical transceivers for OC3 offers the customer a range of design options, including optional DMI (further described later), extended or industrial temperature ranges, and standard push-button or or bail delatch. The AFCT-5765Z family targets applications requiring DMI features, and the AFCT-5760Z family is streamlined for those applications where DMI features are not needed. Throughout this document, AFCT-576xZ will refer collectively to the entire product family encompassing this range of product features.

### Part Number Options

The AFCT-576xZ family consists of the following products:

#### With DMI

Part Number	Temperature	Design
AFCT-5765NLZ	Extended*	Standard
AFCT-5765NPZ	Extended*	Bail
AFCT-5765ANLZ	Industrial*	Standard
AFCT-5765ANPZ	Industrial*	Bail

#### Without DMI

Part Number	Temperature	Design
AFCT-5760NLZ	Extended*	Standard
AFCT-5760NPZ	Extended*	Bail
AFCT-5760ANLZ	Industrial*	Standard
AFCT-5760ANPZ	Industrial*	Bail

\* Extended Temperature Range is -10 to 85 degrees C  
Industrial Temperature Range is -40 to 85 degrees C

### Related Products

- AFCT-5755Z family of OC12 SFP transceivers with DMI
- AFCT-5745L/P family of OC48 SFP transceivers with DMI

### Features

- ROHS compliant
- Optional Digital Diagnostic Monitoring available
  - AFCT-5760Z family: without DMI
  - AFCT-5765Z family: with DMI
- Per SFF-8472, diagnostic features on AFCT-5765Z family enable Diagnostic Monitoring Interface for optical transceivers with real-time monitoring of:
  - Transmitted optical power
  - Received optical power
  - Laser bias current
  - Temperature
  - Supply voltage
- Compliant with SFF-8074i SFP transceiver specification
- Compliant with ITU-T G957 STM-1 L1.1 (40km) Optical Interface
- Compliant with Telcordia GR253 OC3 LR-1 (40km) Optical Interface
- Class 1 CDRH/IEC 825 eye safety compliant
- Operating case temperature range
  - 10 °C to +85 °C (Extended)
  - 40 °C to +85 °C (Industrial)
- Multirate operation from 125 Mb/s to 155 Mb/s
- LC duplex fiber connector
- Manufactured in an ISO 9001 compliant facility

### Applications

- ATM switches and routers
- SONET/SDH switch infrastructure
- Broadband aggregation applications
- Metro edge switching
- Metro and access multi-service platforms
- Suitable for Fast Ethernet applications

## General Features

The AFCT-576xZ family of SFP optical transceivers are high performance, cost effective modules for serial optical data communications applications ranging from 125-155 Mbps. They are designed to provide SONET/SDH compliant connections for 155 Mbps at short and intermediate reach links. This includes specifications for the signal coding, optical fiber and connector types, optical and electrical transmitter characteristics, optical and electrical receiver characteristics, jitter characteristics, and compliance testing methodology for the aforementioned. These transceivers are qualified in accordance with GR-468-CORE.

The transmitter section of the transceivers incorporate a 1300nm Fabry Perot (FP) laser. For each device the receiver section uses an MOVPE grown planar PIN photodetector for low dark current and excellent responsivity. A positive-ECL logic interface simplifies interface to external circuitry. The receiver section contains an InGaAs/InP photo detector and a preamplifier mounted in an optical subassembly. This optical subassembly is coupled to a postamplifier/decision circuit on a circuit board.

The AFCT-576xZ family of optical transceivers adds digital diagnostic monitoring to standard SFP functionality, enabling fault isolation, components monitoring and failure prediction capabilities.

## SFP MSA Compliance

The product package is compliant with the SFP MSA with the LC connector option. The SFP MSA includes specifications for mechanical packaging and performance as well as dc, ac and control signal timing and performance.

The power supply is 3.3 V dc.

The High Speed I/O (HSIO) signal interface is a Low Voltage Differential type. It is ac coupled and terminated internally to the module. The internal termination is a 100 Ohm differential load.

## Installation

The AFCT-576xZ can be installed in any SFF-8074i compliant Small Form Pluggable (SFP) port regardless of host equipment operating status. The module is hot-pluggable, allowing it to be installed while the host system is operating and online. Upon insertion, the transceiver housing makes initial contact with the host board SFP cage, mitigating potential damage due to electrostatic discharge (ESD).

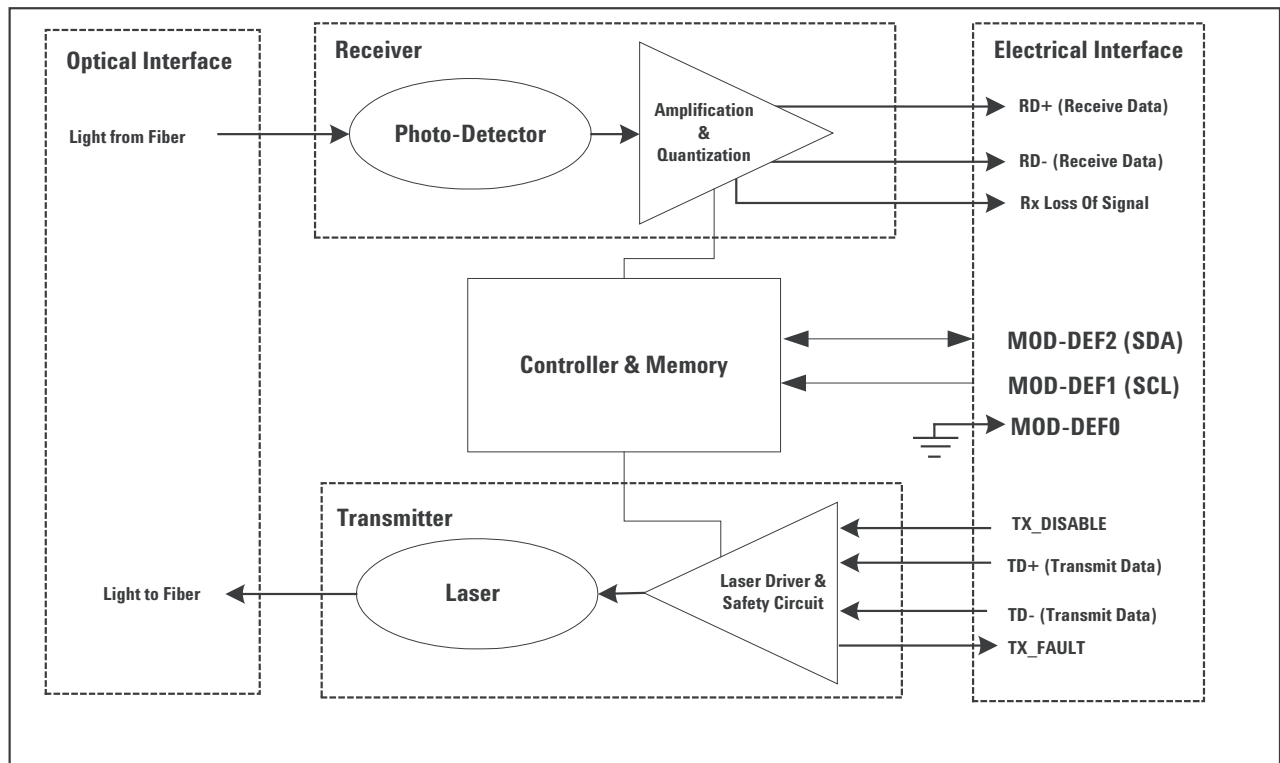

Figure 1. Transceiver Functional Diagram

## Transmitter Section

The transmitter section includes a 1310 nm Fabry-Perot laser and a transmitter driver circuit. The driver circuit maintains a constant optical power level provided that the data pattern is valid for NRZ code. Connection to the transmitter is provided via a LC optical connector.

The transmitter has full IEC 825 and CDRH Class 1 eye safety.

## TX\_DISABLE

The transmitter output can be disabled by asserting pin 3, TX\_DISABLE. A high signal asserts this function while a low signal allows normal laser operation. The transmitter output can also be disabled and monitored via the 2-wire serial interface. In the event of a transceiver fault, such as the activation of the eye safety circuit, toggling of the TX\_DISABLE will reset the transmitter, as depicted in Figure 2.

## TX\_FAULT

A laser fault or a low  $V_{CC}$  condition will activate the transmitter fault signal, TX\_FAULT, and disable the laser. This signal is an open collector output (pull-up required on the host board); A low signal indicates normal laser operation and a high signal indicates a fault. The TX\_FAULT will be latched high when a laser fault occurs and is cleared by toggling the TX\_DISABLE input or power cycling the transceiver. The TX\_FAULT is not latched for Low  $V_{CC}$ . The transmitter fault condition can also be monitored via the two-wire serial interface (address A2, byte 110, bit 2). By default, TX\_FAULT is set to trigger on hardware faults only.

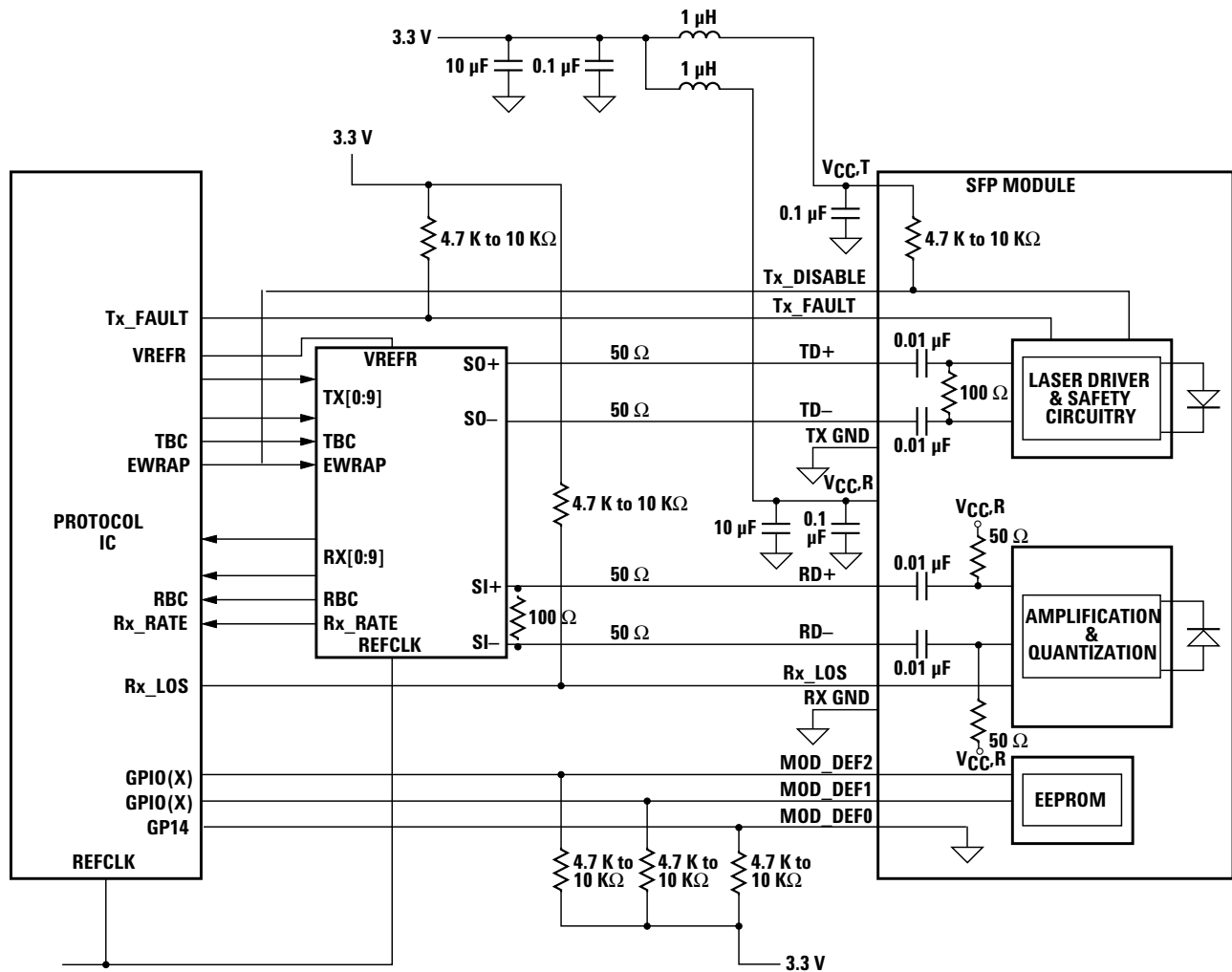

Figure 2. Typical Application Configuration

## Receiver Section

The receiver section for the AFCT-576xZ contains an InGaAs/InP photo detector and a preamplifier mounted in an optical subassembly. This optical subassembly is coupled to a post amplifier/decision circuit on a circuit board. The design of the optical subassembly provides better than 12 dB Optical Return Loss (ORL).

Connection to the receiver is provided via a LC optical connector.

## RX\_LOS

The receiver section contains a loss of signal (RX\_LOS) circuit to indicate when the optical input signal power is insufficient for SONET/SDH compliance. A high signal indicates loss of modulated signal, indicating link failure such as a broken fiber or a failed transmitter. RX\_LOS can be also be monitored via the two-wire serial (address A2, byte 110, bit 1).

## Functional Data I/O

Avago's AFCT-576xZ transceiver is designed to accept industry standard differential signals. The transceiver provides an AC-coupled, internally terminated data interface. Bias resistors and coupling capacitors have been included within the module to reduce the number of components required on the customer's board. Figure 2 illustrates the recommended interface circuit.

## Digital Diagnostic Interface and Serial Identification

The AFCT-576xZ family complies with the SFF-8074i specification, which defines the module's serial identification protocol to use the 2-wire serial CMOS EEPROM protocol of the ATMEL AT24C01A or similar. Standard SFP EEPROM bytes 0-255 are addressed per SFF-8074i at memory address 0xA0 (A0h).

As an enhancement to the conventional SFP interface defined in SFF-8074i, the AFCT-5765Z is also compliant to SFF-8472 (the digital diagnostic interface for SFP). This enhancement adds digital diagnostic monitoring to standard SFP functionality, enabling failure prediction, fault isolation, and component monitoring capabilities.

Using the 2-wire serial interface, the AFCT-5765Z provides real time access to transceiver internal supply voltage and temperature, transmitter output power, laser bias current and receiver average input power, allowing a host to predict system compliance issues. These five parameters are internally calibrated, per the MSA. New digital diagnostic information is accessed per SFF-8472 using EEPROM bytes 0-255 at memory address 0xA2 (A2h).

The digital diagnostic interface also adds the ability to disable the transmitter (TX\_DISABLE), monitor for Transmitter Faults (TX\_FAULT) and monitor for Receiver Loss of Signal (RX\_LOS).

Contents of the MSA-compliant serial ID memory are shown in Tables 3 to 7. The SFF-8074i and SFF-8472 specifications are available from the SFF Committee at <http://www.sffcommittee.org>.

The I2C accessible memory page address 0xB0 is used internally by SFP for the test and diagnostic purposes and it is reserved.

## Predictive Failure Identification

The diagnostic information allows the host system to identify potential link problems. Once identified, a fail-over technique can be used to isolate and replace suspect devices before system uptime is impacted.

## Compliance Prediction

The real-time diagnostic parameters can be monitored to alert the system when operating limits are exceeded and compliance cannot be ensured.

## Fault Isolation

The diagnostic information can allow the host to pinpoint the location of a link problem and accelerate system servicing and minimize downtime.

## Component Monitoring

As part of the host system monitoring, the real time diagnostic information can be combined with system level monitoring to ensure system reliability.

## Application Support

An Evaluation Kit and Reference Designs are available to assist in evaluation of the AFCT-576xZ SFPs. Please contact your local Field Sales representative for availability and ordering details.

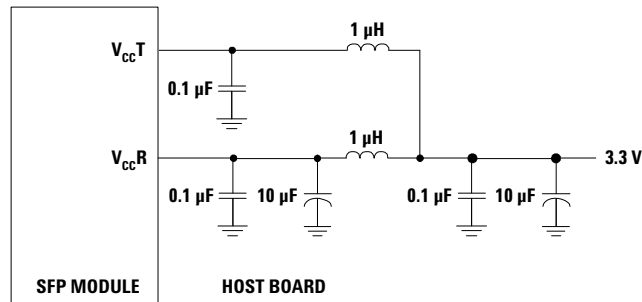

Figure 3. MSA required power supply filter

## Operating Temperature

The AFCT-576xZ family is available in either Extended (-10 to +85°C) or Industrial (-40 to +85°C) temperature ranges.

## Power Supply Noise

The AFCT-576xZ can withstand an injection of PSN on the V<sub>CC</sub> lines of 100 mV ac without a degradation in eye mask margin to 10% on the transmitter and a 1 dB sensitivity penalty on the receiver. This occurs when the product is used in conjunction with the MSA recommended power supply filter shown in Figure 3.

## Regulatory Compliance

The transceiver regulatory compliance is provided in Table 1 as a figure of merit to assist the designer. The overall equipment design will determine the certification level.

**Table 1. Regulatory Compliance**

Feature	Test Method	Performance
Electrostatic Discharge (ESD) to the Electrical Pins	MIL-STD-883C Method 3015.4 JEDEC/EIA JESD22-A114-A	Class 2 (2000 Volts)
Electrostatic Discharge (ESD) to the Duplex LC Receptacle	Bellcore GR1089-CORE	25 kV Air Discharge  10 Zaps at 8 kV (contact discharge) on the electrical faceplate on panel.
Electromagnetic Interference (EMI)	FCC Class B	Applications with high SFP port counts are expected to be compliant; however, margins are dependent on customer board and chassis design.
Immunity	Variation of IEC 61000-4-3	No measurable effect from a 10 V/m field swept from 80 to 1000 MHz applied to the transceiver without a chassis enclosure.
Eye Safety	US FDA CDRH AEL Class 1 EN (IEC) 60825-1, 2, EN60950 Class 1	CDRH Accession Number: 9521220-137T UV Certificate Number: 933/21205741/040
Component Recognition	Underwriter's Laboratories and Canadian Standards Association Joint Component Recognition for Information Technology Equipment Including Electrical Business Equipment	UL file # E173874
ROHS Compliance		Reference to EU RoHS Directive 2002/95/EC

## Electrostatic Discharge (ESD)

There are two conditions in which immunity to ESD damage is important:

The first condition is static discharge to the transceiver during handling such as when the transceiver is inserted into the transceiver port. To protect the transceiver, it is important to use normal ESD handling precautions including the use of grounded wrist straps, work benches, and floor mats in ESD controlled areas. The ESD sensitivity of the AFCT-576xZ is compatible with typical industry production environments.

The second condition is static discharge to the exterior of the host equipment chassis after installation. To the extent that the duplex LC optical interface is exposed to the outside of the host equipment chassis, it may be subject to system-level ESD requirements. The ESD performance of the AFCT-576xZ exceeds typical industry standards. Table 1 documents ESD immunity to both of these conditions.

## Electromagnetic Interference (EMI)

Most equipment designs using the AFCT-576xZ SFPs are subject to the requirements of the FCC in the United States, CENELEC EN55022 (CISPR 22) in Europe and VCCI in Japan. The metal housing and shielded design of the transceiver minimize EMI and provide excellent EMI performance.

## EMI Immunity

The AFCT-576xZ transceivers have a shielded design to provide excellent immunity to radio frequency electromagnetic fields which may be present in some operating environments.

## Eye Safety

The AFCT-576xZ transceivers provide Class 1 eye safety by design. Avago Technologies has tested the transceiver design for regulatory compliance, under normal operating conditions and under a single fault condition. See Table 1.

## Flammability

The AFCT-576xZ family of SFPs is compliant to UL 94V-0.

## Customer Manufacturing Processes

This module is pluggable and is not designed for aqueous wash, IR reflow, or wave soldering processes.

## Caution

The AFCT-576xZ contains no user-serviceable parts. Tampering with or modifying the performance of the AFCT-576xZ will result in voided product warranty. It may also result in improper operation of the transceiver circuitry, and possible over-stress of the laser source. Device degradation or product failure may result. Connection of the AFCT-576xZ to a non-approved optical source, operating above the recommended absolute maximum conditions may be considered an act of modifying or manufacturing a laser product. The person(s) performing such an act is required by law to re-certify and re-identify the laser product under the provisions of U.S. 21 CF.

## Handling Precautions

The AFCT-576xZ can be damaged by current surges or overvoltage. Power supply transient precautions should be taken, and normal handling precautions for electrostatic sensitive devices should be taken.

## Optical Power Budget

The worst-case Optical Power Budget (OPB) in dB for a fiber-optic link is determined by the difference between the minimum transmitter output optical power (dBm avg) and the lowest receiver sensitivity (dBm avg). This OPB provides the necessary optical signal range to establish a working fiber-optic link. The OPB is allocated for the fiber-optic cable length and the corresponding link penalties. For proper link performance, all penalties that affect the link performance must be accounted for within the link optical power budget.

## Process Plug

This transceiver is supplied with a process plug for protection of the optical port within the LC connector receptacle. This process plug prevents contamination during handling, shipping and storage. It is made of a high-temperature, molded sealing material that can withstand +85 °C.

## LC SFP Cleaning Recommendations

In the event of contamination of the optical ports, the recommended cleaning process is the use of forced nitrogen. If contamination is thought to have remained, the optical ports can be cleaned using a NTT international Cletop stick type (diam. 1.25 mm) and HFE7100 cleaning fluid.

**Table 2. Pin description**

Pin	Name	Function/Description	MSA Notes
1	VeeT	Transmitter Ground	
2	TX Fault	Transmitter Fault Indication	Note 1
3	TX Disable	Transmitter Disable - Module disables on high or open	Note 2
4	MOD-DEF2	Module Definition 2 - Two wire serial ID interface	Note 3
5	MOD-DEF1	Module Definition 1 - Two wire serial ID interface	Note 3
6	MOD-DEF0	Module Definition 0 - Grounded in module	Note 3
7	Rate Select	Not Connected	
8	LOS	Loss of Signal	Note 4
9	VeeR	Receiver Ground	
10	VeeR	Receiver Ground	
11	VeeR	Receiver Ground	
12	RD-	Inverse Received Data Out	Note 5
13	RD+	Received Data Out	Note 5
14	VeeR	Receiver Ground	
15	VccR	Receiver Power - 3.3 V $\pm$ 5%	Note 6
16	VccT	Transmitter Power - 3.3 V $\pm$ 5%	Note 6
17	VeeT	Transmitter Ground	
18	TD+	Transmitter Data In	Note 7
19	TD-	Inverse Transmitter Data In	Note 7
20	VeeT	Transmitter Ground	

**Notes:**

- TX Fault is an open collector/drain output, which should be pulled up with a 4.7K – 10K $\Omega$  resistor on the host board. Pull up voltage between 2.0 V and VccT, R+0.3 V. When high, output indicates a laser fault of some kind. Low indicates normal operation. In the low state, the output will be pulled to < 0.8 V. By default, TX Fault is set to trigger only on hardware faults.
- TX Disable input is used to shut down the laser output per the state table below with an external 4.7 - 10 K $\Omega$  pull-up resistor.  
Low (0 - 0.8 V): Transmitter on  
Between (0.8 V and 2.0 V): Undefined  
High (2.0 - 3.465 V): Transmitter Disabled  
Open: Transmitter Disabled
- MOD-DEF 0,1,2. These are the module definition pins. They should be pulled up with a 4.7 - 10 K $\Omega$  resistor on the host board to a supply less than VccT +0.3 V or VccR+0.3 V.  
MOD-DEF 0 is grounded by the module to indicate that the module is present  
MOD-DEF 1 is clock line of two wire serial interface for optional serial ID  
MOD-DEF 2 is data line of two wire serial interface for optional serial ID
- LOS (Loss of Signal) is an open collector/drain output which should be pulled up externally with a 4.7K - 10 K $\Omega$  resistor on the host board to a supply < VccT,R+0.3 V. When high, this output indicates the received optical power is below the worst case receiver sensitivity (as defined by the standard in use). Low indicates normal operation. In the low state, the output will be pulled to < 0.8 V.
- RD-/+: These are the differential receiver outputs. They are ac coupled 100 $\Omega$  differential lines which should be terminated with 100 $\Omega$  differential at the user SERDES. The ac coupling is done inside the module and is thus not required on the host board. The voltage swing on these lines will be between 250 and 2000 mV differential (160 - 1000 mV single ended) when properly terminated.
- VccR and VccT are the receiver and transmitter power supplies. They are defined as 3.135 - 3.465 V at the SFP connector pin. The maximum supply current is 250 mA and the associated inrush current will be no more than 30 mA above steady state after 500 nanoseconds.
- TD-/+: These are the differential transmitter inputs. They are ac coupled differential lines with 100 $\Omega$  differential termination inside the module. The ac coupling is done inside the module and is thus not required on the host board. The inputs will accept differential swings of 500 - 2400 mV (250 - 1200 mV single ended), though it is recommended that values between 500 and 1200 mV differential (250 - 600 mV single ended) be used for best EMI performance.

**Table 3. EEPROM Serial ID Memory Contents - Address A0h**

Byte # Decimal	Dat Hex	Notes	Byte # Decimal	Dat Hex	Notes	Byte # Decimal	Dat Hex	Notes
0	03	SFP physical device	27	20		54	20	
1	04	SFP function defined by serial ID only	28	20		55	20	
2	07	LC optical connector	29	20		56	30	
3	00		30	20		57	30	
4	10	SONET Reach Specifier	31	20		58	31	
5	04	SONET Compliance Code	32	20		59	30	
6	00		33	20		60	Table 4	
7	00		34	20		61	Table 4	
8	00		35	20		62	00	
9	00		36	00		63		Checksum for Bytes 0-62 <sup>3</sup>
10	00		37	00	Hex Byte of Vendor OUI <sup>1</sup>	64	00	
11	05	SONET Scrambled	38	17	Hex Byte of Vendor OUI <sup>1</sup>	65	1A	Hardware SFP Tx_Disable, Tx_Fault & Rx_LOS
12	02	155 Mbit/sec nominal bit rate	39	6A	Hex Byte of Vendor OUI <sup>1</sup>	66	00	Upper Bit Rate Margin
13	00		40	41	A	67	00	Lower Bit Rate Margin
14	28	Link length 9 μm in km	41	46	F	68-83		Vendor Specific Serial Number ASCII characters <sup>4</sup>
15	FF	Link length 9 μm in m	42	43	C	84-91		Vendor Date Code ASCII characters <sup>5</sup>
16	00		43	54	T	92	Table 4	
17	00		44	2D	-	93	Table 4	
18	00		45	35	5	94	Table 4	
19	00		46	37	7	95		Checksum for Bytes 64-94 <sup>3</sup>
20	41	A	47	36	6	96-127	00	Vendor specific EEPROM
21	56	V	48	Table 4		128-255	00	Reserved
22	41	A	49	Table 4				
23	47	G	50	Table 4				
24	4F	O	51	Table 4				
25	20		52	Table 4				
26	20		53	20				

**Notes:**

1. The IEEE Organizationally Unique Identifier (OUI) assigned to Avago is 00-17-6A (3 bytes of hex).
2. Laser wavelength is represented in 16 unsigned bits.
3. Addresses 63 and 95 are checksums calculated (per SFF-8472 and SFF-8074) and stored prior to product shipment.
4. Addresses 68-83 specify the ASCII serial number and will vary on a per unit basis.
5. Addresses 84-91 specify the ASCII date code and will vary on a per date code basis.



**Table 4. Individual Identifiers**

Byte #	AFCT-5760NLZ		AFCT-5760NPZ		AFCT-5760ANLZ		AFCT-5760ANPZ	
	Hex	Notes	Hex	Notes	Hex	Notes	Hex	Notes
48	30	0	30	0	30	0	30	0
49	4E	N	4E	N	41	A	41	A
50	4C	L	50	P	4E	N	4E	N
51	5A	Z	5A	Z	4C	L	50	P
52	20		20		5A	Z	5A	Z
60	05	1310nm	05	1310nm	05	1310nm	05	1310nm
61	1E		1E		1E		1E	
92	00		00		00		00	
93	00		00		00		00	
94	00		00		00		00	

Byte #	AFCT-5765NLZ		AFCT-5765NPZ		AFCT-5765ANLZ		AFCT-5765ANPZ	
	Hex	Notes	Hex	Notes	Hex	Notes	Hex	Notes
48	35	5	35	5	35	5	35	5
49	4E	N	4E	N	41	A	41	A
50	4C	L	50	P	4E	N	4E	N
51	5A	Z	5A	Z	4C	L	50	P
52	20		20		5A	Z	5A	Z
60	05	1310nm	05	1310nm	05	1310nm	05	1310nm
61	1E		1E		1E		1E	
92	68		68		68		68	
93	F0		F0		F0		F0	
94	01		01		01		01	

**Table 5. EEPROM Serial ID Memory Contents - Address A2h (AFCT-5765Z family only)**

Byte #Decimal	Notes	Byte #Decimal	Notes	Byte #Decimal	Notes
0	Temp H Alarm MSB <sup>1</sup>	26	Tx Pwr L Alarm MSB <sup>4</sup>	104	Real Time Rx P <sub>AV</sub> MSB <sup>5</sup>
1	Temp H Alarm LSB <sup>1</sup>	27	Tx Pwr L Alarm LSB <sup>4</sup>	105	Real Time Rx P <sub>AV</sub> LSB <sup>5</sup>
2	Temp L Alarm MSB <sup>1</sup>	28	Tx Pwr H Warning MSB <sup>4</sup>	106	Reserved
3	Temp L Alarm LSB <sup>1</sup>	29	Tx Pwr H Warning LSB <sup>4</sup>	107	Reserved
4	Temp H Warning MSB <sup>1</sup>	30	Tx Pwr L Warning MSB <sup>4</sup>	108	Reserved
5	Temp H Warning LSB <sup>1</sup>	31	Tx Pwr L Warning LSB <sup>4</sup>	109	Reserved
6	Temp L Warning MSB <sup>1</sup>	32	Rx Pwr H Alarm MSB <sup>5</sup>	110	Status/Control - see Table 6
7	Temp L Warning LSB <sup>1</sup>	33	Rx Pwr H Alarm LSB <sup>5</sup>	111	Reserved
8	V <sub>CC</sub> H Alarm MSB <sup>2</sup>	34	Rx Pwr L Alarm MSB <sup>5</sup>	112	Flag Bits - see Table 7
9	V <sub>CC</sub> H Alarm LSB <sup>2</sup>	35	Rx Pwr L Alarm LSB <sup>5</sup>	113	Flag Bit - see Table 7
10	V <sub>CC</sub> L Alarm MSB <sup>2</sup>	36	Rx Pwr H Warning MSB <sup>5</sup>	114	Reserved
11	V <sub>CC</sub> L Alarm LSB <sup>2</sup>	37	Rx Pwr H Warning LSB <sup>5</sup>	115	Reserved
12	V <sub>CC</sub> H Warning MSB <sup>2</sup>	38	Rx Pwr L Warning MSB <sup>5</sup>	116	Flag Bits - see Table 7
13	V <sub>CC</sub> H Warning LSB <sup>2</sup>	39	Rx Pwr L Warning LSB <sup>5</sup>	117	Flag Bits - see Table 7
14	V <sub>CC</sub> L Warning MSB <sup>2</sup>	40-55	Reserved	118	Reserved
15	V <sub>CC</sub> L Warning LSB <sup>2</sup>	56-94	External Calibration Constants <sup>6</sup>	119	Reserved
16	Tx Bias H Alarm MSB <sup>3</sup>	95	Checksum for Bytes 0-94 <sup>7</sup>	120-122	Reserved
17	Tx Bias H Alarm LSB <sup>3</sup>	96	Real Time Temperature MSB <sup>1</sup>	123	
18	Tx Bias L Alarm MSB <sup>3</sup>	97	Real Time Temperature LSB <sup>1</sup>	124	
19	Tx Bias L Alarm LSB <sup>3</sup>	98	Real Time Vcc MSB <sup>2</sup>	125	
20	Tx Bias H Warning MSB <sup>3</sup>	99	Real Time Vcc LSB <sup>2</sup>	126	
21	Tx Bias H Warning LSB <sup>3</sup>	100	Real Time Tx Bias MSB <sup>3</sup>	127	Reserved <sup>8</sup>
22	Tx Bias L Warning MSB <sup>3</sup>	101	Real Time Tx Bias LSB <sup>3</sup>	128-247	Customer Writable <sup>9</sup>
23	Tx Bias L Warning LSB <sup>3</sup>	102	Real Time Tx Power MSB <sup>4</sup>	248-254	Vendor Specific
24	Tx Pwr H Alarm MSB <sup>4</sup>	103	Real Time Tx Power LSB <sup>4</sup>	255	
25	Tx Pwr H Alarm LSB <sup>4</sup>				

**Notes:**

1. Temperature (Temp) is decoded as a 16 bit signed two's complement integer in increments of 1/256 °C.
2. Supply voltage (V<sub>CC</sub>) is decoded as a 16 bit unsigned integer in increments of 100 μV.
3. Laser bias current (Tx Bias) is decoded as a 16 bit unsigned integer in increments of 2 μA.
4. Transmitted average optical power (Tx Pwr) is decoded as a 16 bit unsigned integer in increments of 0.1 μW.
5. Received average optical power (Rx Pwr) is decoded as a 16 bit unsigned integer in increments of 0.1 μW.
6. Bytes 55-94 are not intended for use with AFCT-5765xxxx, but have been set to default values per SFF-8472.
7. Bytes 95 is a checksum calculated (per SFF-8472) and stored prior to product shipment.
8. Byte 127 accepts a write but performs no action (reserved legacy byte).
9. Bytes 128-247 are write enabled (customer writable).
10. Byte 255 bits 2 and 3 control laser margining (per Table 7) when an enabling password is entered into bytes 123-126.

**Table 6. EEPROM Serial ID Memory Contents - Address A2h, Byte 110 (AFCT-5765Z family only)**

Bit #	Status/Control Name	Description
7	Tx Disable State	Digital state of SFP Tx Disable Input Pin (1 = Tx_Disable asserted)
6	Soft Tx Disable	Read/write bit for changing digital state of SFP Tx_Disable function <sup>1</sup>
5	Reserved	
4	Rx Rate Select State	Digital state of SFP Rate Select Input Pin (1 = full bandwidth of 155 Mbit) <sup>2</sup>
3	Reserved	
2	Tx Fault State	Digital state of the SFP Tx Fault Output Pin (1 = Tx Fault asserted) <sup>3</sup>
1	Rx LOS State	Digital state of the SFP LOS Output Pin (1 = LOS asserted)
0	Data Ready (Bar)	Indicates transceiver is powered and real time sense data is ready (0 = Ready)

**Notes:**

1. Bit 6 is logic OR'd with the SFP Tx\_Disable input pin 3 ... either asserted will disable the SFP transmitter.
2. AFCT-5765Z does not respond to state changes on Rate Select Input Pin. It is internally hardwired to full bandwidth.
3. By default, TX Fault is set to trigger only on hardware faults.

**Table 7. EEPROM Serial ID Memory Contents - Address A2h, Bytes 112, 113, 116, 117 (AFCT-5765Z family only)**

Byte	Bit #	Flag Bit Name	Description
112	7	Temp High Alarm	Set when transceiver internal temperature exceeds high alarm threshold.
	6	Temp Low Alarm	Set when transceiver internal temperature exceeds alarm threshold.
	5	V <sub>CC</sub> High Alarm	Set when transceiver internal supply voltage exceeds high alarm threshold.
	4	V <sub>CC</sub> Low Alarm	Set when transceiver internal supply voltage exceeds low alarm threshold.
	3	Tx Bias High Alarm	Set when transceiver laser bias current exceeds high alarm threshold.
	2	Tx Bias Low Alarm	Set when transceiver laser bias current exceeds low alarm threshold.
	1	Tx Power High Alarm	Set when transmitted average optical power exceeds high alarm threshold.
	0	Tx Power Low Alarm	Set when transmitted average optical power exceeds low alarm threshold.
113	7	Rx Power High Alarm	Set when received P_Avg optical power exceeds high alarm threshold.
	6	Rx Power Low Alarm	Set when received P_Avg optical power exceeds low alarm threshold.
	0-5	Reserved	
116	7	Temp High Warning	Set when transceiver internal temperature exceeds high warning threshold.
	6	Temp Low Warning	Set when transceiver internal temperature exceeds low warning threshold.
	5	V <sub>CC</sub> High Warning	Set when transceiver internal supply voltage exceeds high warning threshold.
	4	V <sub>CC</sub> Low Warning	Set when transceiver internal supply voltage exceeds low warning threshold.
	3	Tx Bias High Warning	Set when transceiver laser bias current exceeds high warning threshold.
	2	Tx Bias Low Warning	Set when transceiver laser bias current exceeds low warning threshold.
	1	Tx Power High Warning	Set when transmitted average optical power exceeds high warning threshold.
	0	Tx Power Low Warning	Set when transmitted average optical power exceeds low warning threshold.
117	7	Rx Power High Warning	Set when received P_Avg optical power exceeds high warning threshold.
	9	Rx Power Low Warning	Set when received P_Avg optical power exceeds low warning threshold.
	0-5	Reserved	

## Optical Parameters

### Absolute Maximum Ratings

Absolute maximum ratings are those values beyond which functional performance is not intended, device reliability is not implied, and damage to the device may occur.

Parameter	Symbol	Minimum	Maximum	Unit	Notes
Storage Temperature (non-operating)	T <sub>S</sub>	-40	+85	°C	
Relative Humidity	RH	0	85	%	
Supply Voltage	V <sub>CC</sub>	-0.5	3.63	V	
Input Voltage on any Pin	V <sub>I</sub>	-0.5	V <sub>CC</sub>	V	
Receiver Optical Input	P <sub>INABS</sub>		0	dBm	

### Recommended Multirate Operating Conditions

Typical operating conditions are those values for which functional performance and device reliability is implied.

Parameter	Symbol	Minimum	Typical	Maximum	Unit	Notes
Case Operating Temperature						
AFCT-576xNLZ/NPZ	T <sub>C</sub>	-10		+85	°C	
AFCT-576xANLZ/ANPZ	T <sub>C</sub>	-40		+85	°C	
Supply Voltage	V <sub>CC</sub>	3.1	3.3	3.5	V	

### Transceiver Electrical Characteristics for multirate operations at Fast Ethernet (125 Mbit/s) and OC-3 (155 Mbit/s) \*6

Parameter	Symbol	Minimum	Typical	Maximum	Unit	Notes
Module supply current	I <sub>CC</sub> T			250	mA	1
Power Dissipation	P <sub>DISS</sub>			875	mW	
<b>AC Electrical Characteristics</b>						
Power Supply Noise Rejection	PSNR	100			mV	2
In-rush Current				30	mA	
<b>DC Electrical Characteristics</b>						
<b>Signal Outputs:</b>						
Transmit Fault (TX_FAULT)	V <sub>OH</sub>	2.0		3.5	V	
Loss of Signal (LOS)	V <sub>OL</sub>	0		0.8	V	3
<b>Signal Inputs:</b>						
Transmitter Disable (TX_DISABLE)	V <sub>IH</sub>	2.0		3.5	V	
MOD-DEF1, 2	V <sub>IL</sub>	0		0.8	V	6
<b>Data Input:</b>						
Transmitter Single Ended Input Voltage (TD±)	V <sub>I</sub>	250		1200	mV	4
<b>Data Output:</b>						
Receiver Single Ended Output Voltage (RD±)	V <sub>O</sub>	250		1000	mV	5

#### Notes:

- MSA gives max current at 300 mA.
- MSA filter is required on host board 10 Hz to 2 MHz.
- LVTTL, External 4.7-10 KΩ pull up resistor required on host board to voltage less than V<sub>CC</sub> + 0.3 V.
- Internally ac coupled and terminated (100 Ω differential).
- Internally ac coupled and load termination located at the user SERDES.
- Minimum input to MOD-DEF1,2 is 0.7\*V<sub>CC</sub>

## Transmitter Optical Characteristics for multirate operations at Fast Ethernet (125 Mbit/s) and OC-3 (155 Mbit/s)

Parameter	Symbol	Minimum	Typical*	Maximum	Unit	Notes
Optical Output Power	P <sub>OUT</sub>	-5		0	dBm	1
Center Wavelength	λ <sub>C</sub>	1270		1360	nm	
Spectral Width - RMS	σ			3	nm	2
Optical Rise Time	t <sub>r</sub>			2.5	ns	3
Optical Fall Time	t <sub>f</sub>			2.5	ns	3
Tx disable OFF power	P <sub>OFF</sub>			-45	dBm	
Extinction Ratio	E <sub>r</sub>	10			dB	
Eye Mask Margin	EMM	30			%	4
Jitter Generation	pk to pk			70	mUI	5
	RMS			7	mUI	5

\*Typicals indicated expected values for room temperature measurements +25 °C

### Notes:

1. The output power is coupled into a 1 m single mode fiber. Minimum output optical level is at end of life
2. The relationship between FWHM and RMS values for spectral width can be derived from the Gaussian shaped spectrum which results in RMS=FWHM/2.35
3. These are unfiltered 20-80% values.
4. 30% margin to eye mask in Telcordia GR-253-CORE and ITU-T G.957
5. Jitter measurements taken with Avago OMNIBER 718 in accordance with GR253

## Receiver Optical Characteristics for multirate operations at Fast Ethernet (125 Mbit/s) and OC-3 (155 Mbit/s)

Parameter	Symbol	Minimum	Typical	Maximum	Unit	Notes
Receiver Sensitivity	P <sub>INMIN</sub>			-34	dBm	1
Receiver Overload	P <sub>INMAX</sub>	0			dBm	
Input Operating Wavelength	λ	1261		1360	nm	
LOS Deassert	P <sub>LOSD</sub>			-34.5	dBm	
LOS Assert	P <sub>LOSA</sub>	-45			dBm	
LOS Hysteresis	P <sub>H</sub>	0.5		4	dB	

### Notes:

1. The receiver is guaranteed to provide output data with a Bit Error Rate better than or equal to  $1 \times 10^{-10}$  measured with TX powered and carrying data.

## Transceiver Digital Diagnostic Monitor (Real Time Sense) Characteristics (AFCT-5765Z family only)

Parameter	Symbol	Min.	Typ.	Max.	Unit	Reference
Transceiver Internal Temperature Accuracy	T <sub>INT</sub>	-3.0		+3.0	°C	1
Transceiver Internal Supply Voltage Accuracy	V <sub>INT</sub>	-3.0		+3.0	%	2
Transmitter Laser dc Bias Current Accuracy	I <sub>INT</sub>	-10		+10	%	3
Transmitted Average Optical Output Power Accuracy	P <sub>T</sub>	-3.0		+3.0	dB	
Received Average Optical Input Power Accuracy	P <sub>R</sub>	-3.0		+3.0	dB	

### Notes:

1. Temperature was measured internal to the transceiver. Valid from = -10 °C to +85 °C or from -40°C to +85°C. For calibration to an external temperature, please contact Avago Technologies.
2. Reference voltage is 3.3 V.
3. Valid from 0 to 50 mA, avg.

## Transceiver Timing Characteristics

Parameter	Symbol	Minimum	Maximum	Unit	Notes
Hardware TX_DISABLE Assert Time	t <sub>off</sub>		10	ms	Note 1
Hardware TX_DISABLE Negate Time	t <sub>on</sub>		1	ms	Note 2
Time to initialize, including reset of TX_FAULT	t <sub>init</sub>		300	ms	Note 3
Hardware TX_FAULT Assert Time	t <sub>fault</sub>		100	ms	Note 4
Hardware TX_DISABLE to Reset	t <sub>reset</sub>	10		ms	Note 5
Hardware RX_LOS Assert Time	t <sub>loss_on</sub>		100	ms	Note 6
Hardware RX_LOS De-Assert Time	t <sub>loss_off</sub>		100	ms	Note 7
Software TX_DISABLE Assert Time	t <sub>off_soft</sub>		100	ms	Note 8
Software TX_DISABLE Negate Time	t <sub>on_soft</sub>		100	ms	Note 9
Software Tx_FAULT Assert Time	t <sub>fault_soft</sub>		100	ms	Note 10
Software Rx_LOS Assert Time	t <sub>loss_on_soft</sub>		100	ms	Note 11
Software Rx_LOS De-Assert Time	t <sub>loss_off_soft</sub>		100	ms	Note 12
Analog parameter data ready	t <sub>data</sub>		1000	ms	Note 13
Serial bus hardware ready	t <sub>serial</sub>		300	ms	Note 14
Write Cycle Time	t <sub>write</sub>		10	ms	Note 15
Serial ID Clock Rate	f <sub>serial_clock</sub>		400	kHz	

### Notes:

1. Time from rising edge of TX\_DISABLE to when the optical output falls below 10% of nominal.
2. Time from falling edge of TX\_DISABLE to when the modulated optical output rises above 90% of nominal.
3. Time from power on or falling edge of Tx\_Disable to when the modulated optical output rises above 90% of nominal.
4. From power on or negation of TX\_FAULT using TX\_DISABLE.
5. Time TX\_DISABLE must be held high to reset the laser fault shutdown circuitry.
6. Time from loss of optical signal to Rx\_LOS Assertion.
7. Time from valid optical signal to Rx\_LOS De-Assertion.
8. Time from two-wire interface assertion of TX\_DISABLE (A2h, byte 110, bit 6) to when the optical output falls below 10% of nominal. Measured from falling clock edge after stop bit of write transaction.
9. Time from two-wire interface de-assertion of TX\_DISABLE (A2h, byte 110, bit 6) to when the modulated optical output rises above 90% of nominal.
10. Time from fault to two-wire interface TX\_FAULT (A2h, byte 110, bit 2) asserted.
11. Time for two-wire interface assertion of Rx\_LOS (A2h, byte 110, bit 1) from loss of optical signal.
12. Time for two-wire interface de-assertion of Rx\_LOS (A2h, byte 110, bit 1) from presence of valid optical signal.
13. From power on to data ready bit asserted (A2h, byte 110, bit 0). Data ready indicates analog monitoring circuitry is functional.
14. Time from power on until module is ready for data transmission over the serial bus (reads or writes over A0h and A2h).
15. Time from stop bit to completion of a 1-8 byte write command.

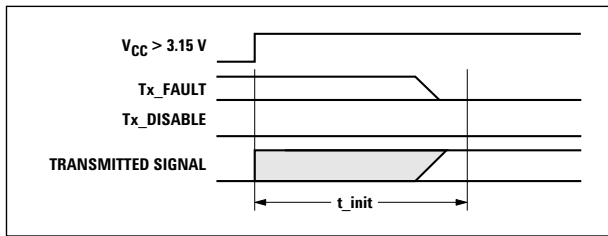

t-init: TX DISABLE NEGATED

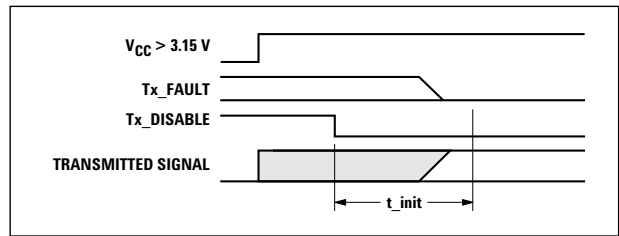

t-init: TX DISABLE ASSERTED

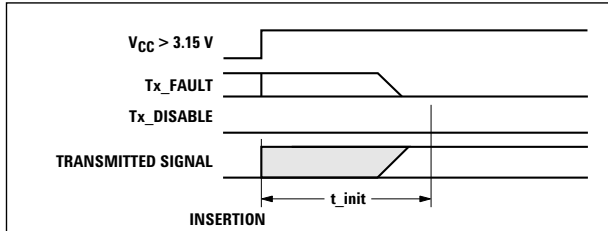

t-init: TX DISABLE NEGATED, MODULE HOT PLUGGED

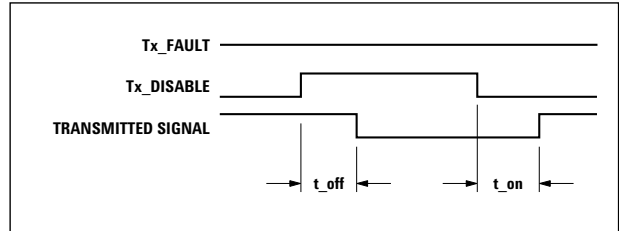

t-off & t-on: TX DISABLE ASSERTED THEN NEGATED

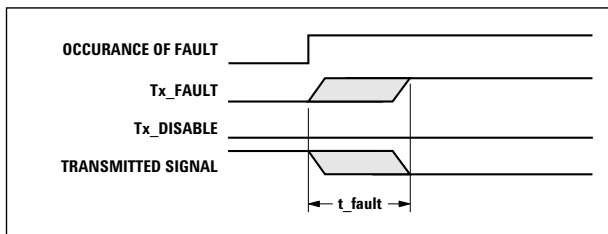

t-fault: TX FAULT ASSERTED, TX SIGNAL NOT RECOVERED

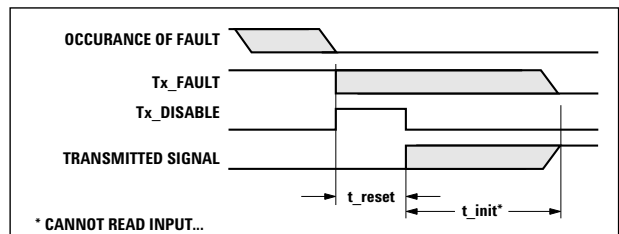

t-reset: TX DISABLE ASSERTED THEN NEGATED, TX SIGNAL RECOVERED

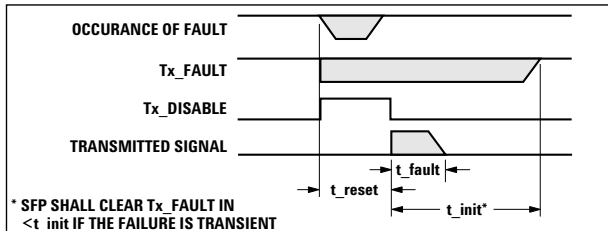

t-fault: TX DISABLE ASSERTED THEN NEGATED, TX SIGNAL NOT RECOVERED

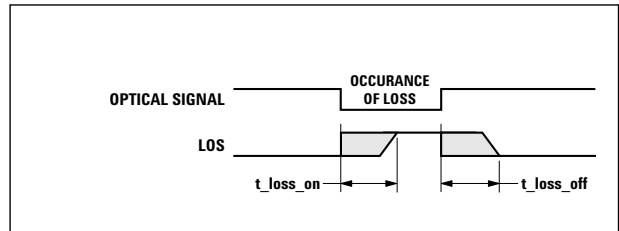

t-loss-on & t-loss-off

Figure 5. Timing Diagrams

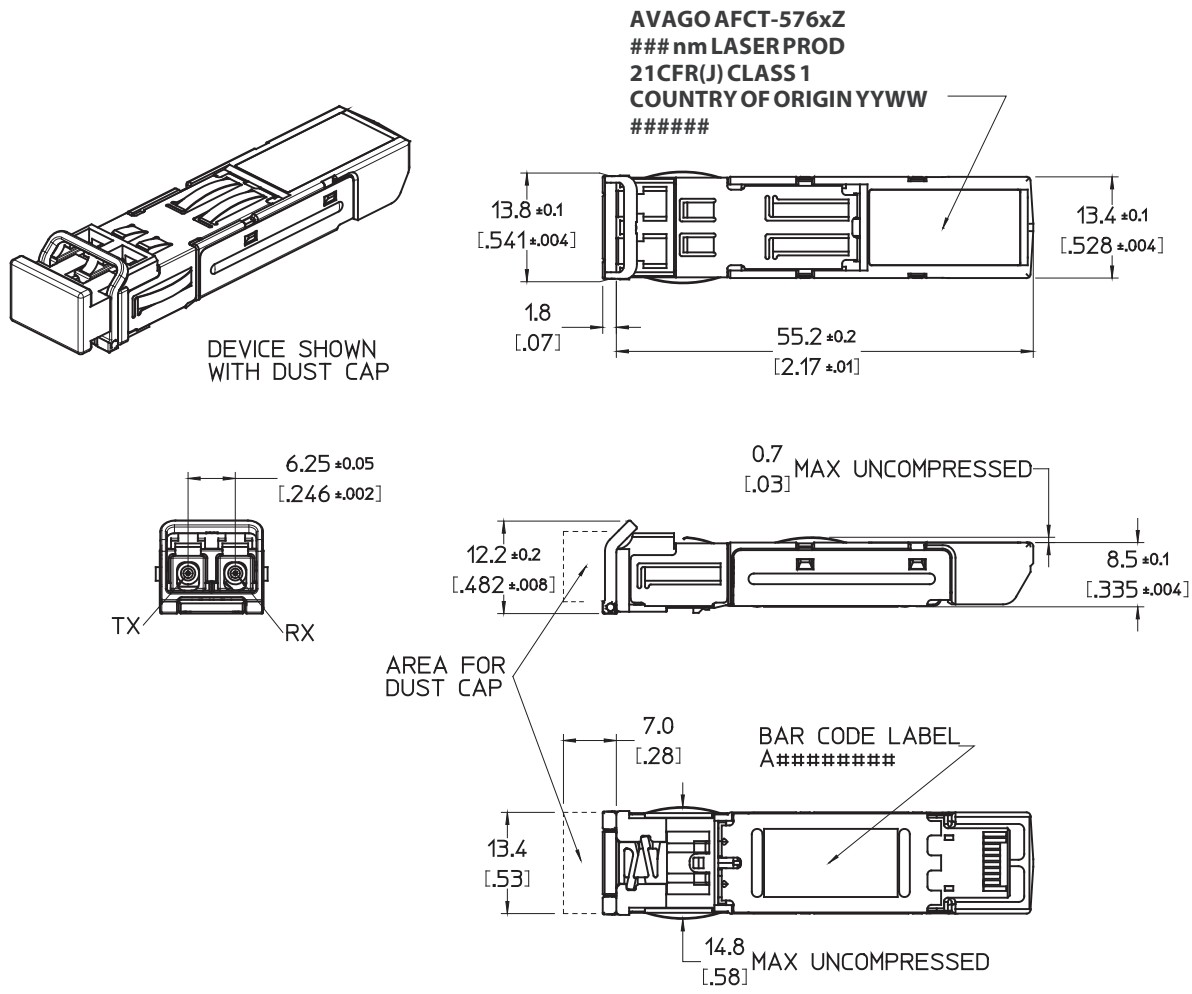

Notes:  
 1. Bail delatch is colored BLUE for SONET/Single-Mode Identification.

Figure 6. Module Drawing



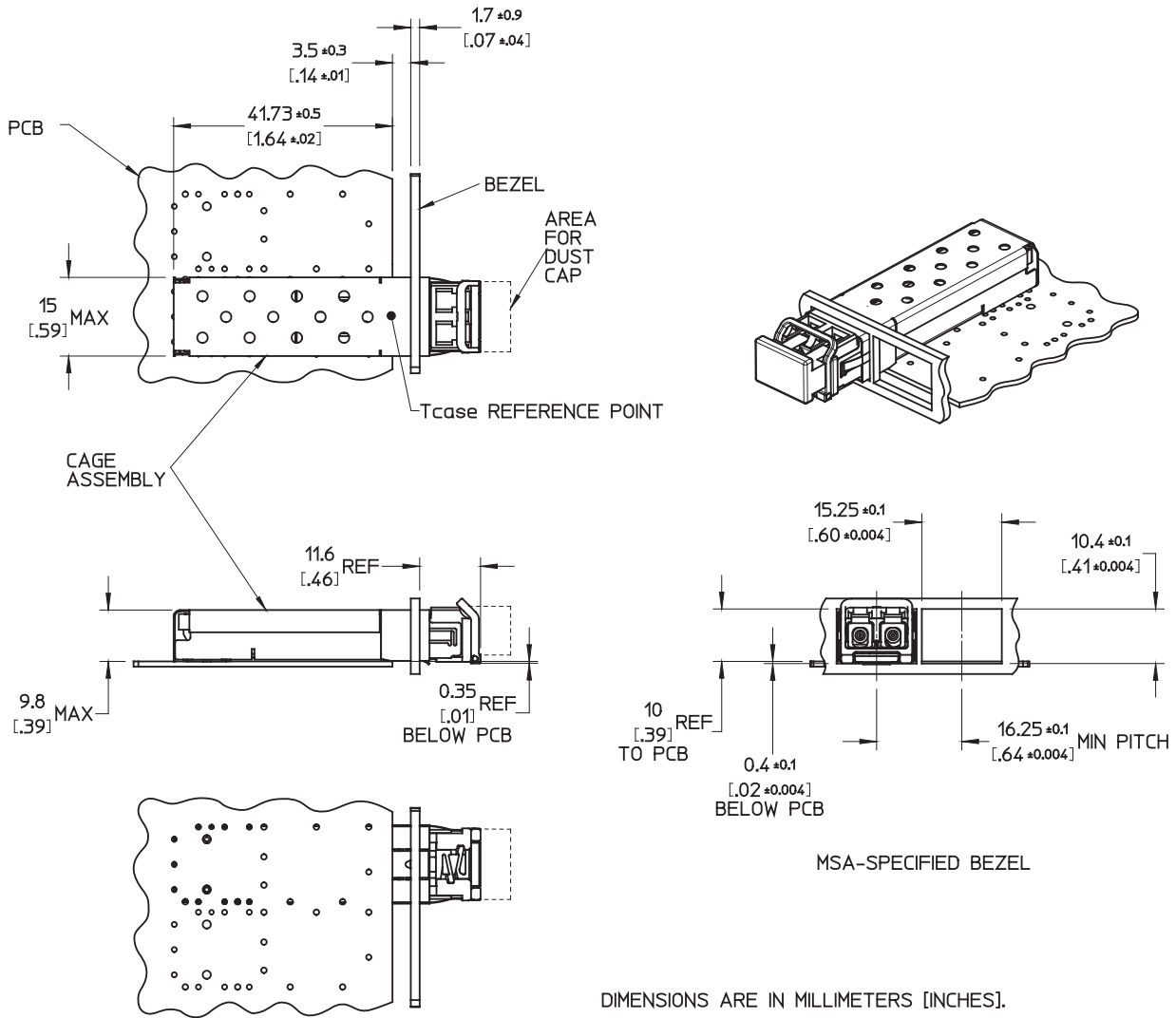

Figure 7. Assembly Drawing



## Ordering Information

Please contact your local field sales engineer or one of Avago Technologies franchised distributors for ordering information. For technical information, please visit Avago Technologies' web-page at [www.avagotech.com](http://www.avagotech.com) or contact one of Avago Technologies' regional Technical Response Centers. For information related to SFF Committee documentation, visit [www.sffcommittee.org](http://www.sffcommittee.org).

### 1300nm FP Laser (Operating Case Temperature -10 to +85 °C)

#### *With DMI*

AFCT-5765NLZ standard de-latch

AFCT-5765NPZ bail de-latch

#### *Without DMI*

AFCT-5760NLZ standard de-latch

AFCT-5760NPZ bail de-latch

### 1300nm FP Laser (Operating Case Temperature -40 to +85 °C)

#### *With DMI*

AFCT-5765ANLZ standard de-latch

AFCT-5765ANPZ bail de-latch

#### *Without DMI*

AFCT-5760ANLZ standard de-latch

AFCT-5760ANPZ bail de-latch

## EEPROM Content and / or Label Options

AFCT-5760XXXX-YYY

AFCT-5765XXXX-YYY

Where "XXXX" refers to product option  
"YYY" is customer specific

For product information and a complete list of distributors, please go to our web site: [www.avagotech.com](http://www.avagotech.com)

Avago, Avago Technologies, and the A logo are trademarks of Avago Technologies in the United States and other countries. Data subject to change. Copyright © 2005-2012 Avago Technologies. All rights reserved. Obsoletes AV01-0519EN AV02-0140EN - September 12, 2012



## X-ON Electronics

Largest Supplier of Electrical and Electronic Components

*Click to view similar products for [Fibre Optic Transmitters, Receivers, Transceivers](#) category:*

*Click to view products by [Broadcom](#) manufacturer:*

Other Similar products are found below :

[STV.2413-574-00262](#) [TRPRG1VA1C000E2G](#) [TOTX1350\(V,F\)](#) [FTLX3813M349](#) [SCN-1428SC](#) [LTK-ST11MB](#) [HFD8003-002/XBA](#)  
[HFD3020-500-ABA](#) [FTLF1429P3BCVA](#) [S6846](#) [SCN-2638SC](#) [FTL410QE4N](#) [FTLC9555FEPM](#) [TQS-QG4H9-J83](#) [SCN-1570SC](#) [SCN-](#)  
[1601SC](#) [SCN-1338SC](#) [SFPPT-SR3-01](#) [HFD8003-500-XBA](#) [SCN-1383SC](#) [2333569-1](#) [LNK-ST11HB-R6](#) [FTL4C1QL3L](#) [FTL4C1QE3L](#)  
[FTL4C1QL3C](#) [SPTSHP3PMCDF](#) [SPTSBP4LLCDF](#) [SPTMBP1PMCDF](#) [SPTSHP2PMCDF](#) [SF-NLNAMB0001](#) [SPTSHP2SLCDF](#)  
[SPTSQP4LLCDF](#) [1019682](#) [1019683](#) [1019705](#) [HFBR-1415Z](#) [AFBR-5803ATQZ](#) [AFBR-5803ATZ](#) [PLR135/T9](#) [TGW-Q14BB-FCQ](#) [AFBR-](#)  
[5803AZ](#) [TQS-Q1LH8-XCA03](#) [TQS-Q1LH8-XCA05](#) [TQS-Q1LH8-XCA10](#) [TQS-Q1LH9-2CA](#) [HFBR-1414Z](#) [HFBR-1527Z](#) [HFBR-1528Z](#)  
[HFBR-2406Z](#) [HFBR-2505AZ](#)