

ASMT-Bx20

PCB-Based Subminiature Lamps (PCB PolyLED)

Description

The Broadcom[®] ASMT-Bx20 is an environmental friendly green product of unique PCB-based subminiature lamps, namely PCB PolyLED. These PolyLEDs come in untinted, nondiffused package to cater for various product themes and ease handling applications.

The small size, narrow footprint, and high brightness make these LEDs excellent for backlighting, status indication, and panel illumination applications.

The available colors are AlInGaP Red, AlInGaP Green, InGaN Blue, and AlInGaP Amber.

To facilitate pick-and-place operation, these PCB PolyLEDs are shipped in tape and reel, with 1500 units per reel. The package is compatible with reflow soldering and binned by both color and intensity.

Features

- Small foot print
- Available in four colors
- Low power consumption
- Nondiffused dome for high brightness
- Supreme product quality and reliability
- Operating temperature range of $-40\text{ }^{\circ}\text{C}$ to $+85\text{ }^{\circ}\text{C}$
- Package in 8-mm tape on 7-in. diameter reels
- Compatible with automated placement equipment
- Compatible with infrared and vapor phase reflow soldering process

Applications

- Panel indicator
- LCD backlighting
- Symbol backlighting
- Pushbutton backlighting
- Indoor mono/full color sign

Package Dimensions

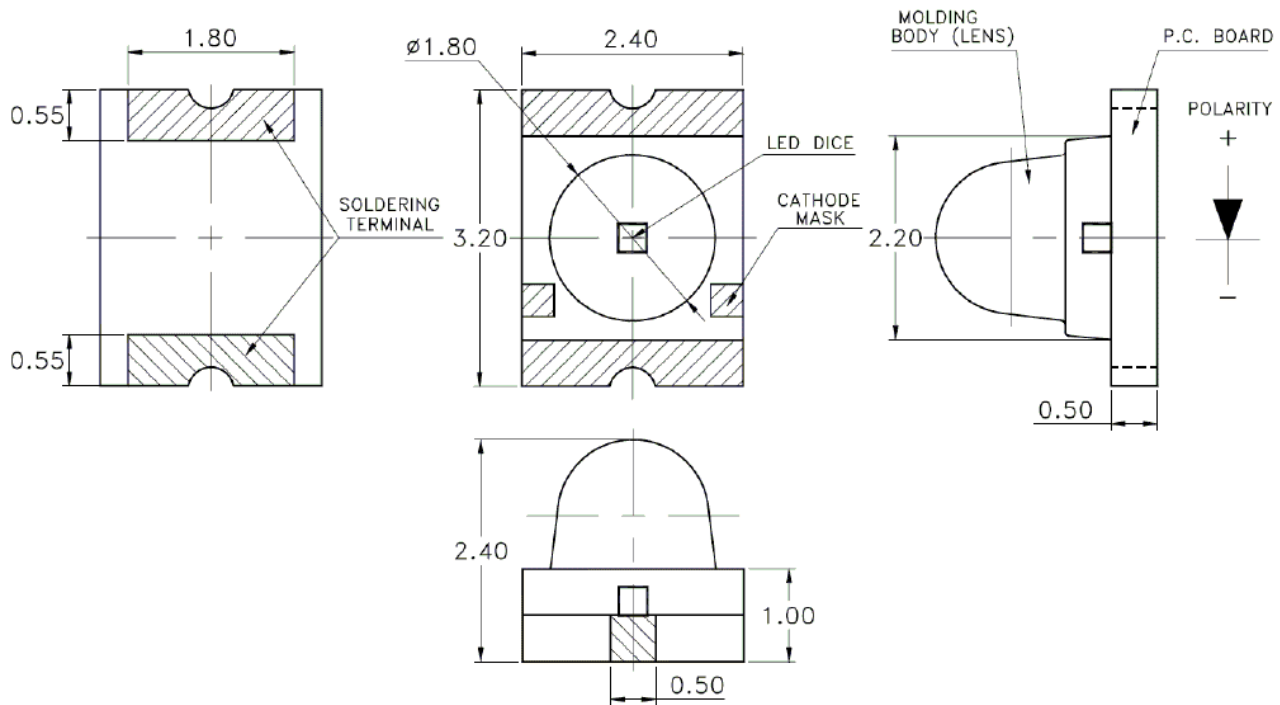

NOTE:

1. All dimensions are in millimeters.
2. Tolerance is ± 0.1 mm unless otherwise specified.

Device Selection Guide

Part Number	Die Technology	Color	Package Description
ASMT-BA20	AllnGaP	Amber	Untinted, nondiffused
ASMT-BG20	AllnGaP	Green	Untinted, nondiffused
ASMT-BR20	AllnGaP	Red	Untinted, nondiffused
ASMT-BB20	InGaN	Blue	Untinted, nondiffused

Part Numbering System

A S M T - B x₁ 2 0 - x₂ x₃ x₄ x₅ 0

Number	Field	Option	Description
x ₁	Color	A	Amber
		G	Green
		R	Red
		B	Blue
x ₂	Die Technology	A	AllnGaP
		N	InGaN
x ₃	Min Iv Bin Options	See the Light Intensity (IV) Bin Limits table	
x ₄	Max Iv Bin Options		
x ₅	Color Bin Selection	See the Color Bin Limits tables	

Absolute Maximum Ratings at $T_A = 25^\circ\text{C}$

Parameter	AllnGaP	InGaN	Units
DC Forward Current ^a	30	20	mA
Reverse Voltage ($I_R = 100\text{ mA}$)	5	5	V
LED Junction Temperature	95	95	$^\circ\text{C}$
Operating Temperature Range	-40 to +85		$^\circ\text{C}$
Storage Temperature Range	-40 to +85		$^\circ\text{C}$
Soldering Temperature (Pb-Free)	260 $^\circ\text{C}$ for 10 seconds		

a. Derate linearly as shown in Figure 5.

Electrical Characteristics at $T_A = 25^\circ\text{C}$

Part Number	Forward Voltage V_F (V) ^a at $I_F = 20\text{ mA}$		Reverse Breakdown V_R (V) at $I_R = 100\ \mu\text{A}$	Thermal Resistance $R_{\theta\text{J-PIN}}$ ($^\circ\text{C}/\text{W}$)
	Typ.	Max.	Min.	Typ.
AllnGaP Amber	2.0	2.4	5	450
AllnGaP Green	2.0	2.4	5	450
AllnGaP Red	2.0	2.4	5	450
InGaN Blue	3.2	3.8	5	450

a. V_F tolerance is $\pm 0.1\text{V}$.

Optical Characteristics at $T_A = 25^\circ\text{C}$

Part Number	Luminous Intensity I_V ^a (mcd) at 20 mA	Peak Wavelength λ_{peak} (nm)	Dominant Wavelength λ_d ^b (nm)	Viewing Angle $2\theta_{1/2}$ ^c (Degrees)
	Typ.	Typ.	Typ.	Typ.
AllnGaP Amber	750	592	590	15
AllnGaP Green	650	565	569	15
AllnGaP Red	650	635	626	15
InGaN Blue	650	470	468	15

a. The luminous intensity, I_V , is measured at the peak of the spatial radiation pattern, which may not be aligned with the mechanical axis of the LED package.

b. The dominant wavelength, λ_d , is derived from the CIE Chromaticity Diagram and represents the perceived color of the device.

c. $\theta_{1/2}$ is the off-axis angle where the luminous intensity is $\frac{1}{2}$ the peak intensity.

Light Intensity (I_V) Bin Limits¹

Bin ID	Intensity (mcd)	
	Min.	Max.
P	45.00	71.50
Q	71.50	112.50
R	112.50	180.00
S	180.00	285.00
T	285.00	450.00
U	450.00	715.00
V	715.00	1125.00
W	1125.00	1800.00
X	1800.00	2850.00
Y	2850.00	4500.00

Tolerance: $\pm 15\%$.

Color Bin Limits¹

Amber Color Bins¹

Bin ID	Dominant Wavelength (nm)	
	Min.	Max.
1	582.0	584.5
2	584.5	587.0
3	587.0	589.5
4	589.5	592.0
5	592.0	594.5
6	594.5	597.0

Tolerance: ± 1 nm.

Green Color Bins¹

Bin ID	Dominant Wavelength (nm)	
	Min.	Max.
1	561.5	564.5
2	564.5	567.5
3	567.5	570.5
4	570.5	573.5
5	573.5	576.5

Tolerance: ± 1 nm.

Red Color Bins¹

Bin ID	Dominant Wavelength (nm)	
	Min.	Max.
—	620.0	635.0

Tolerance: ± 1 nm.

Blue Color Bins¹

Bin ID	Dominant Wavelength (nm)	
	Min.	Max.
1	460.0	465.0
2	465.0	470.0
3	470.0	475.0
4	475.0	480.0

Tolerance: ± 1 nm.

- Bin categories are established for classification of products. Products may not be available in all categories. Contact your Broadcom representative for information on current available bins.

Figure 1: Recommended Soldering Land Pattern

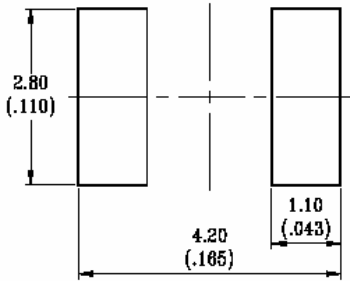

NOTE:

1. All dimensions are in millimeters (inches).
2. Tolerance is ± 0.1 mm (± 0.004 in.) unless otherwise specified.

Figure 2: Relative Intensity vs. Wavelength

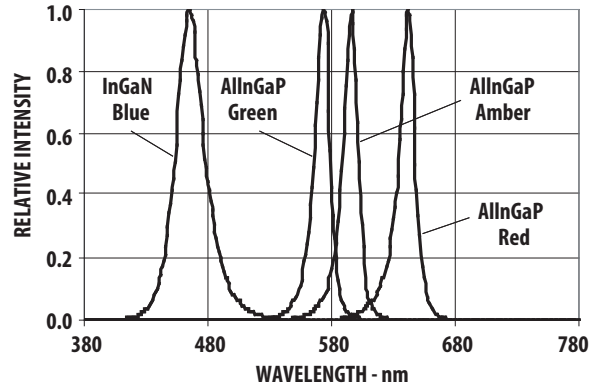

Figure 3: Forward Current vs. Forward Voltage

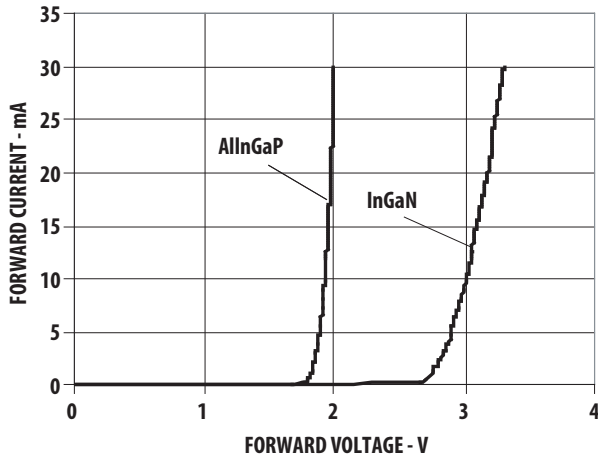

Figure 4: Relative Luminous Intensity vs. DC Forward Current

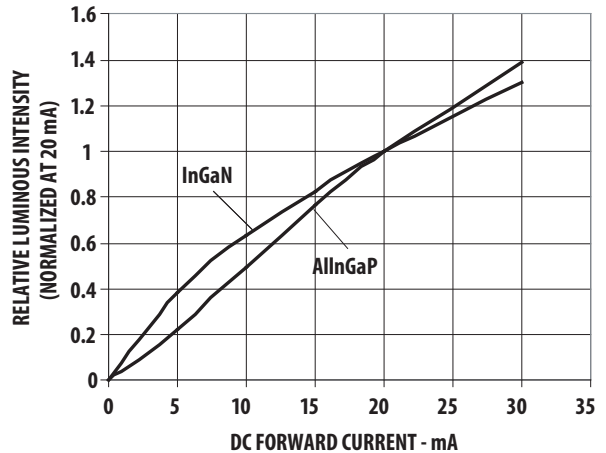

Figure 5: Maximum Forward Current vs. Ambient Temperature. For AllnGaP and InGaN derating based on $T_{JMAX}=95^{\circ}C$.

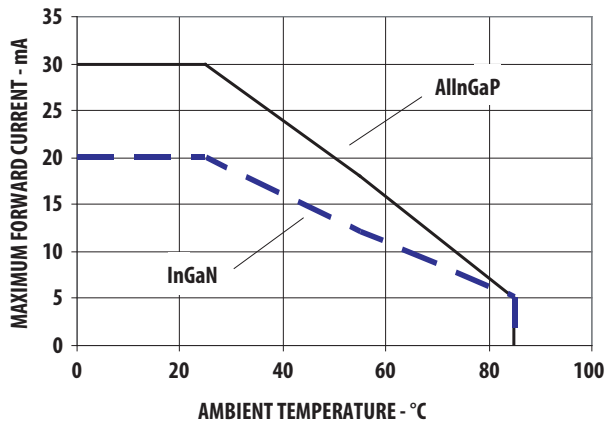

Figure 6: Radiation Pattern

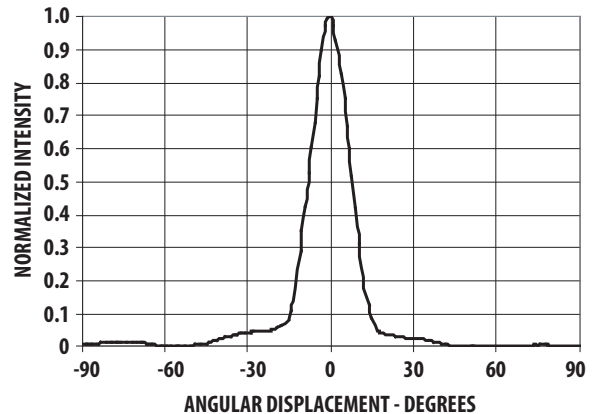

Figure 7: Recommended Reflow Soldering Profile

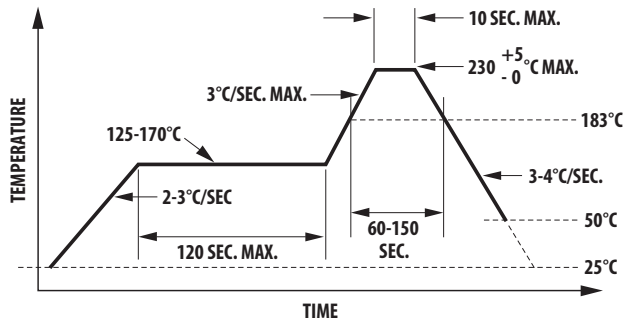
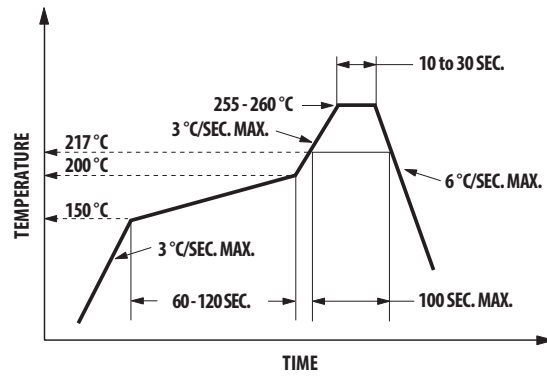

Figure 8: Recommended Pb-Free Reflow Soldering Profile



(Acc. to J-STD-020C)

Figure 9: Reeling Orientation

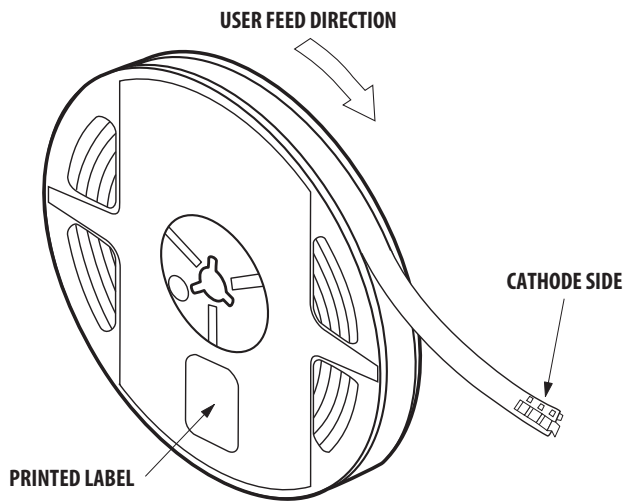
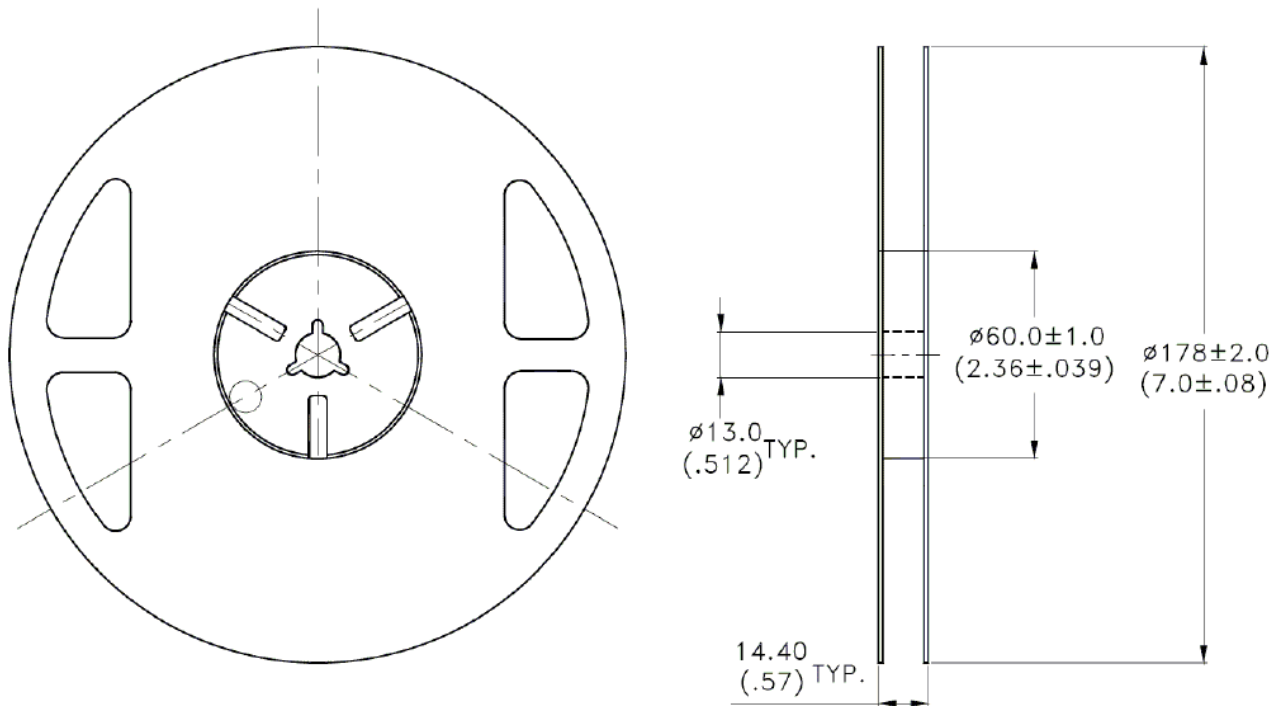
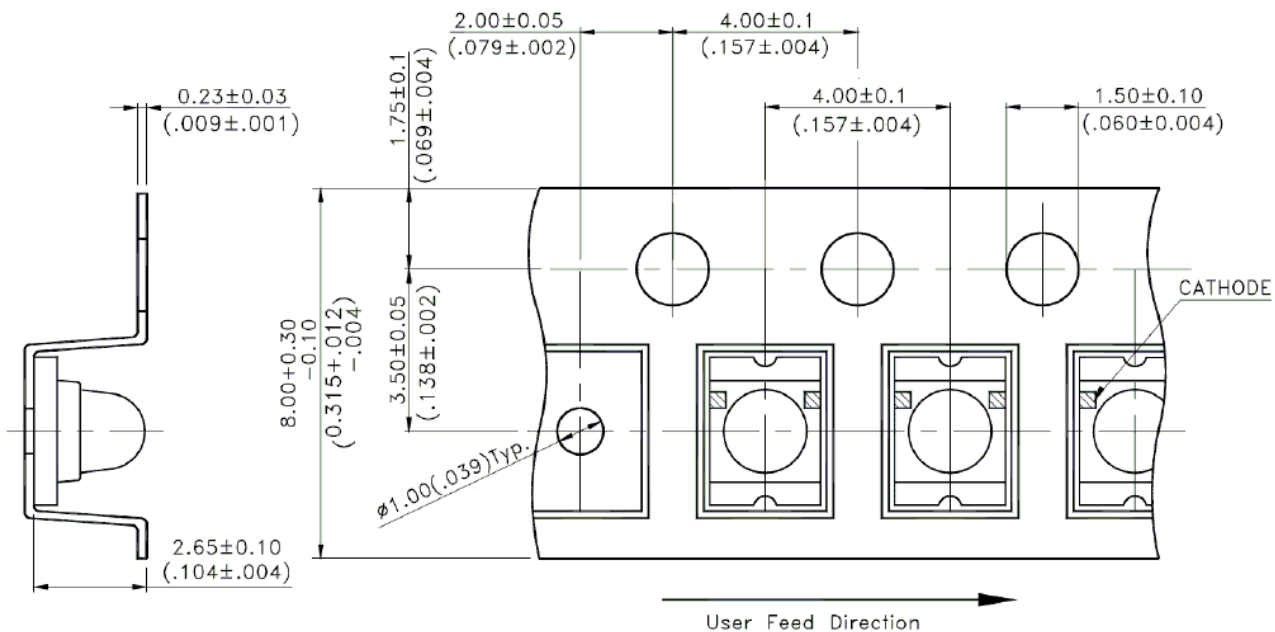

Figure 10: Reel Dimensions



NOTE: All dimensions are in millimeters (inches).

Figure 11: Tape Dimensions



NOTE: All dimensions are in millimeters (inches).

Broadcom, the pulse logo, Connecting everything, Avago Technologies, Avago, and the A logo are among the trademarks of Broadcom and/or its affiliates in the United States, certain other countries, and/or the EU.

Copyright © 2008–2019 Broadcom. All Rights Reserved.

The term “Broadcom” refers to Broadcom Inc. and/or its subsidiaries. For more information, please visit www.broadcom.com.

Broadcom reserves the right to make changes without further notice to any products or data herein to improve reliability, function, or design. Information furnished by Broadcom is believed to be accurate and reliable. However, Broadcom does not assume any liability arising out of the application or use of this information, nor the application or use of any product or circuit described herein, neither does it convey any license under its patent rights nor the rights of others.



X-ON Electronics

Largest Supplier of Electrical and Electronic Components

Click to view similar products for [Standard LEDs - SMD category](#):

Click to view products by [Broadcom manufacturer](#):

Other Similar products are found below :

[LTST-C19GD2WT](#) [LTST-N683GBEW](#) [LTW-170ZDC](#) [LTW-M140SZS40](#) [598-8110-100F](#) [598-8170-100F](#) [598-8610-202F](#) [67-22VRVGC/TR8](#) [AAAF5060QBFSEEZGS](#) [HLMP-6305-L0011](#) [ALMD-LB36-SV002](#) [APT1608QGW](#) [15-21UYC/S530-A3/TR8](#) [EASV1803BA0](#) [LS A676-P2S1-1](#) [SML310BATT86](#) [SML-512VWT86A](#) [SML-LX0606SISUGC/A](#) [SML-LXL1307SRC-TR](#) [SML-LXR851SIUPGUBC](#) [LT1ED53A](#) [FAT801-S](#) [AM27ZGC03](#) [APB3025SGNC](#) [APFA3010SURKCGKQBDC](#) [APHK1608VGCA](#) [APT2012QGW](#) [CLX6D-FKB-CN1R1H1BB7D3D3](#) [LTST-C250KGKT](#) [LTW-020ZDCG](#) [LTW-21TS5](#) [LTW-220DS5](#) [JANTXM19500/521-02](#) [UYGT801-S](#) [LO T67F-V1AB-24-1](#) [YGFR411-H](#) [SML-LX0402IC-TR](#) [CMDA20AYAA7D1S](#) [CMDA16AYDR7A1X](#) [339-1SURYGW/S530-A2](#) [598-8040-100F](#) [598-8070-100F](#) [598-8140-100F](#) [598-8610-200F](#) [EAPL3527GA5](#) [67-11/BHC-M1N2B8Y/2A0](#) [SML-LXL1209SYC/ATR](#) [EASV3020YGA0](#) [EAST16086YA5](#) [CMD91-21VRC/TR7](#)