

10/100BASE-TX OCTAL-Φ™ TRANSCEIVER

FEATURES

- Eight-port 10BASE-T/100BASE-TX/100BASE-FX transceiver
- HP Auto-MDIX automatically uncrosses cable pairs
- Advanced CableChecker™ cable diagnostics software diagnoses and pinpoints cable faults to reduce supports calls
- Optimized for use with Broadcom's StrataSwitch™ Family
- Cost effective process technology: 0.18u CMOS
- Serial Media Independent Interface (SMII) and Source Synchronous SMII (SSSMII)
- Fully programmable LED drivers and serial LED output
- Low power: 200 mW per port
- Low-voltage core: 1.8V
- QFP or BGA package options
- Most widely deployed and reliable PHY architecture: Over a billion Broad-Φ™ ports shipped

SUMMARY OF BENEFITS

- Target usage: Fast Ethernet switches.
- Low-power dual-supply 2.5V/1.8V CMOS technology.
- Smallest footprint per port available.
- Measures 14 mm x 20 mm for eight ports.
- Single-chip device contains eight independent Fast Ethernet transceivers.
- Performs all physical layer interface functions for 100BASE-TX full-duplex or half-duplex Ethernet on category 5 unshielded twisted-pair (UTP) cable, 10BASE-T full-duplex or half-duplex Ethernet on category 3, 4, or 5 UTP cable, and 100BASE-FX full-duplex or half-duplex on fiber optic cable.
- Compliant with IEEE 802.3 standard.
- IEEE 1149.1 (JTAG) scan chain support.
- Fully customizable LED functions. Up to 8 LED signals per port.

24-Port 10/100BASE-T Ethernet Switch Example

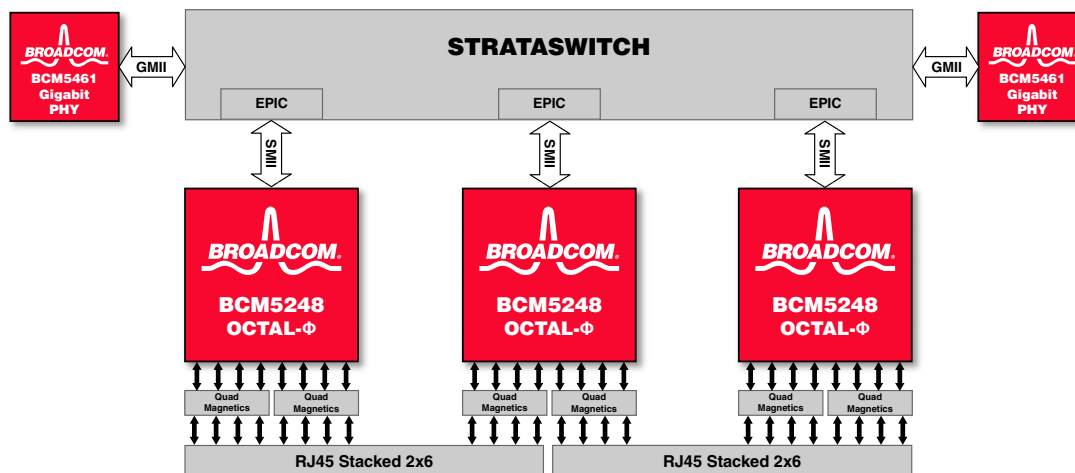

OVERVIEW

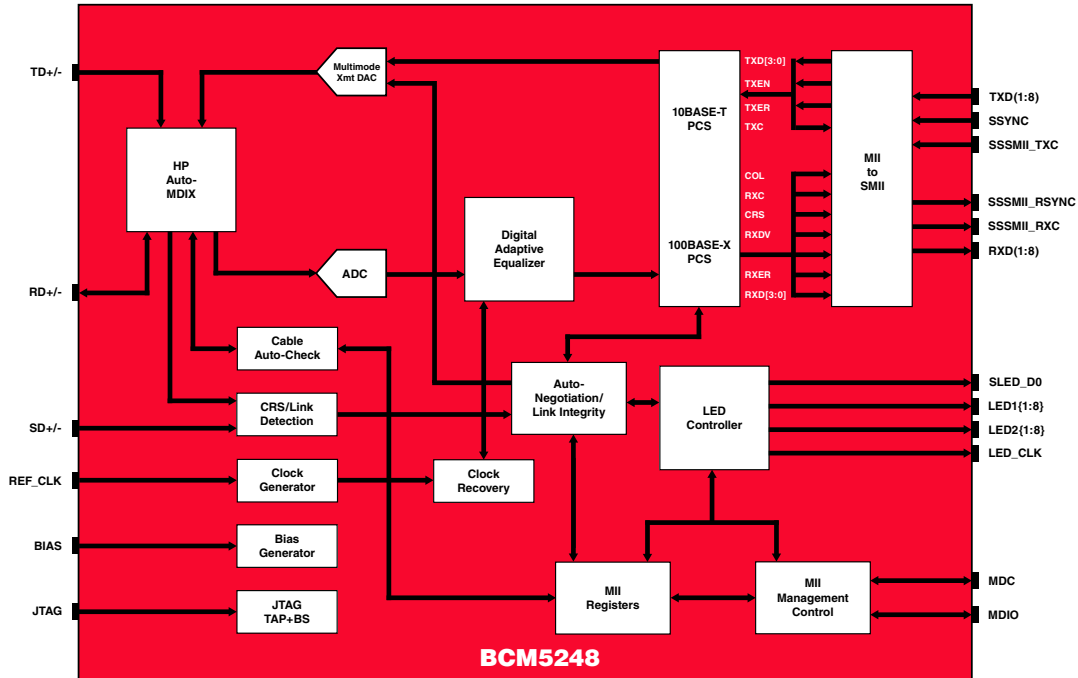

BCM5248 Reference Design

The Broadcom BCM5248 is a single-chip device containing eight independent Fast Ethernet transceivers. Each performs all of the physical layer functions for 100BASE-TX full- or half-duplex Ethernet on category 5 UTP cable and 10BASE-T full- or half-duplex Ethernet on category 3, 4, or 5 UTP cable. The BCM5248 chip performs encoding and decoding, clock and data recovery, digital adaptive equalization, line transmission, carrier sense and link integrity monitoring, auto-negotiation and SMI/SSSMII management functions. The BCM5248 is compliant with the IEEE 802.3 standard.

The BCM5248 offers alternative connection to fiber optic modules for 100BASE-FX operation. The enhanced FX mode allows 100BASE-FX operation without the use of signal detect pins. The standard FX mode allows 100BASE-FX operation with modules that require the PHY to use signal detect inputs to disable receive data in the absence of a received optical signal.

The BCM5248 can be connected to a switch controller through the SMI or SSSMII on one side and to the network media on the other side through isolation transformers. The BCM5248 operates from 1.8 and 2.5V/3.3V power supplies; the I/O operates at either 2.5V or 3.3V.

The BCM5248 contains an advanced cable diagnostic capability to detect shorts or opens in a UTP cable and the distance to the fault, allowing system administrators to quickly determine the source of a fault. Additionally, the BCM5248 can detect the length of a good, operating link, which allows mapping of an entire physical cable plant.

The BCM5248 includes support for HP Auto-MDIX which enables the transceiver to automatically detect and correct cable that is wired incorrectly. With the HP Auto-MDIX feature, all ports on a switch can be connected to any other 10/100 port on any switch, hub, or network interface card, using crossover or straight-through cables interchangeably. This makes installation, debugging, and maintenance of the network simpler and less expensive to the end user.

In addition to two fully programmable LED driver pins per port, the BCM5248 also supports a serial LED driver output that can be used to drive up to eight LEDs per port, to indicate the status of link, speed, duplex, transmit or receive activity, or arbitrary functions programmed by the user. The BCM5248 is offered in a 128 PQFP and a 256-ball BGA package.

Broadcom®, the pulse logo, Connecting everything®, and the Connecting everything logo are among the trademarks of Broadcom Corporation and/or its affiliates in the United States, certain other countries and/or the EU. Any other trademarks or trade names mentioned are the property of their respective owners.

Connecting
everything®



BROADCOM CORPORATION
16215 Alton Parkway, P.O. Box 57013
Irvine, California 92619-7013

© 2006 by BROADCOM CORPORATION. All rights reserved.

5248-PB01-R 04/17/06

Phone: 949-450-8700
Fax: 949-450-8710
E-mail: info@broadcom.com
Web: www.broadcom.com

X-ON Electronics

Largest Supplier of Electrical and Electronic Components

Click to view similar products for [LIN Transceivers](#) category:

Click to view products by [Broadcom](#) manufacturer:

Other Similar products are found below :

[MC33911BAC](#) [MLX80004KLW-BAA-001-SP](#) [MCP2021T-500E/MD](#) [MCP2021-500E/P](#) [MCP2022P-330E/SL](#) [TLE8457DLEXUMA1](#)
[MCP2022-330E/SL](#) [MCP2022-500ESL](#) [NCV7420D26R2G](#) [TJA1027T/20/1J](#) [TJA1027T/20,118](#) [TJA1021T/20/CM,118](#) [MCP2003A-E/P](#)
[MCP2003A-E/SN](#) [MCP2003-E/P](#) [MCP2004A-E/P](#) [MCP2004A-E/SN](#) [MCP2004-E/P](#) [MCP2004-E/SN](#) [MCP2021-330E/MD](#) [MCP2021-](#)
[330E/P](#) [MCP2021-330E/SN](#) [MCP2021-500E/SN](#) [MCP2021A-330E/MD](#) [MCP2021A-330E/SN](#) [MCP2021A-500E/SN](#) [MCP2022-500E/P](#)
[MCP2022A-330E/SL](#) [MCP2022A-500E/SL](#) [MCP2025-330E/MD](#) [MCP2025-330E/P](#) [MCP2025-330E/SN](#) [MCP2025-500E/P](#) [MCP2025-](#)
[500E/SN](#) [MCP2050-330E/SL](#) [MCP2022A-330E/ST](#) [MCP2022A-500E/ST](#) [MC33662LEF](#) [MCP2003B-E/SN](#) [MCP2021T-500ESN](#)
[MAX13021ASA+](#) [MCP2003BT-E/MC](#) [TJA1020T/CM.118](#) [TJA1021T/20/C.118](#) [STLD1TR](#) [TLIN2022DMTRQ1](#) [TLE7258DXUMA1](#)
[MCP2022P-500E/SL](#) [MCP2021P-500E/SN](#) [MD-012HRL](#)