

# Managed Switch with 24 FE Ports + 4-GbE Interface

## GENERAL DESCRIPTION

The BCM53242M is a ninth-generation RoboSwitch™ design based on the field-proven BCM5324 device. This integrated 0.13 $\mu$ -CMOS device combines all the functions of a high-speed switch system including packet buffers, PHY transceivers, Media Access Controllers (MACs), address management, and a nonblocking switch fabric. It is designed to be fully compliant with the IEEE 802.3 and IEEE 802.3x specifications, including the MAC control PAUSE frame, auto-negotiation and with all industry-standard Ethernet and Fast Ethernet devices.

The BCM53242M contains 24 full-duplex 10Base-T/100Base-TX Fast Ethernet transceivers with Advanced Cable Diagnostics support. Each performs all physical layer interface functions for 10Base-T Ethernet on Category 3, 4, or 5 Unshielded Twisted Pair (UTP) cable and 100Base-TX Fast Ethernet on Category 5 UTP cable. The BCM53242M has two GMII/RGMII/TBI interfaces that provide flexible 10/100/1000Base-TX/FX connectivity. An additional MAC is included for CPU connection via RvMII/MII interface.

The BCM53242M has a rich feature set suitable for streaming VoIP, video, and data traffic for multimedia applications. The BCM53242M supports up to four QoS queues per port. Traffic QoS can be assigned based on Port-ID, MAC Address, 802.1p or DiffServ. Together with 4K entries, 802.1Q VLAN, 802.1x EAPOL protocol filtering, MAC-based link aggregation with dynamic failover, per-port bandwidth/rate control, MAC address locking, and IGMP snooping at Layer 3 allow system vendors to build advanced L2+ switch systems for the Multitenant/Multidweller Unit (MTU/MDU) markets. The BCM53242M provides 70+ on-chip MIB counters to collect receive and transmit statistics for each port.

## FEATURES

- Ninth-generation L2+ Fast Ethernet switch with two GMII/RGMII/TBI interfaces.
  - 24-port 10/100 transceivers for TX/EFX.
  - Advanced Cable Diagnostic support.
  - 25 10/100 MACs.
  - Two Gigabit MACs.
  - 3-Mbit (384 KB) packet buffer and control memory.
  - Management Port with RvMII/MII interface.
- Nonblocking switch fabric for 24 FE + 2 GbE ports.
- Jumbo frame support up to 2048 bytes.
- Flexible TCAM-based Compact Field Processor for packet classification and filtering.
- Packet Remarking, VID Replacement.
  - 802.1p PCP, DSCP remarking.
- Optimized for managed switch design.
- 802.1p, Port, MAC, Protocol, Customer\_VID, and DiffServ (IPv4/IPv6) based QoS packet classification with four priority queues.
- Port-based VLAN.
- 802.1Q-based VLAN with 4K entries.
- MAC-based VLAN with 512 entries.
- Protocol-based VLAN with 16 entries.
- VLAN Translation.
- Double tagging.
  - UNI/NNI configuration per port for edge access application.
  - QinQ packet transmission through NNI port.
  - Programmable global SP\_TPID.
  - Programmable SP\_VID through flexible mapping.
- Link Aggregation support with automatic link fail-over.
- Programmable per-port Bandwidth/Rate control.
- Protected port security feature.
- Port mirroring (Ingress/Egress), IGMP Layer 3. snooping and MLD snooping.
- Spanning Tree support (802.1d/1s/1w).
- Supports 802.1x EAPOL higher layer protocol.
- Programmable Broadcast, Multicast, and Unknown Unicast storm control. 8K MAC addresses with automatic learning and aging.
- MDC/MDIO and SPI interfaces.
- 4K-entry Multicast Address table.
- Hardware supports SNMP, RMON.
- Internal oscillator simplifies design and reduces cost.
- JTAG.
- 2.5V and 1.2V, typical power consumption: ~ 4.3W.
- 400-pin PBGA package.

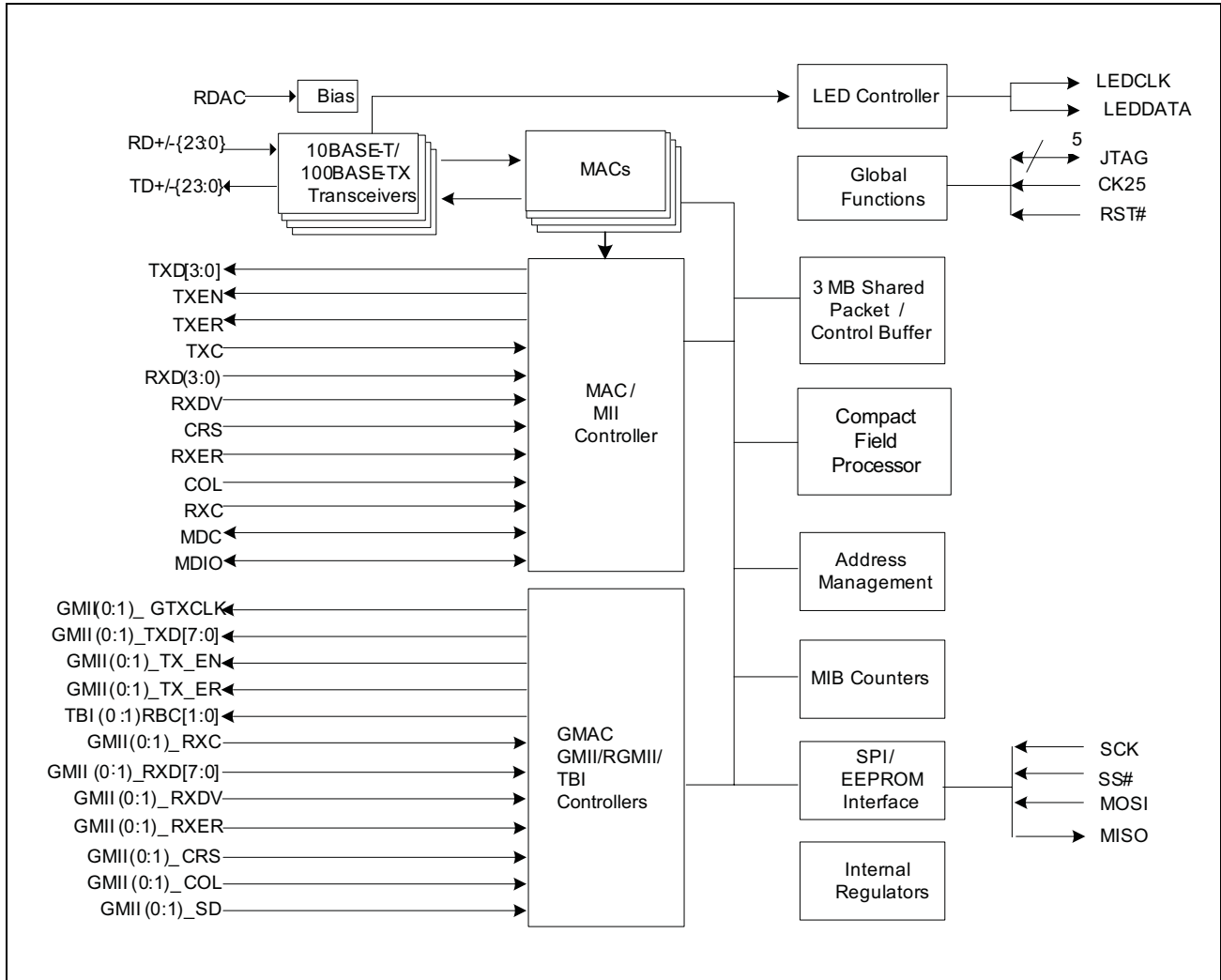

Figure 1: Functional Block Diagram

Broadcom

## REVISION HISTORY

<i>Revision</i>	<i>Date</i>	<i>Change Description</i>
53242M-DS302-R	07/28/11	<b>Updated:</b> <ul style="list-style-type: none"><li>• Table 43: "Hardware Signal Definitions," on page 132</li><li>• Table 44: "Pin Assignment (Sorted by Ball Number)," on page 145</li><li>• Table 59: "LED Control Register (Page 00h: Address 5Ah)," on page 164</li><li>• Table 287: "802.1Q Control 3 Register (Pages: 34h, Address 08h–0Fh)," on page 305</li><li>• Table 323: "Port MIB Registers (Page 68h–84h)," on page 336</li><li>• Table 345: "Serial LED Timing," on page 361</li></ul> <b>Removed:</b> <ul style="list-style-type: none"><li>• Second note in "Programming Example" on page 86.</li></ul>
532XXXCT-DS3XX1-D4	04/15/09	<b>Updated:</b> <ul style="list-style-type: none"><li>• Figure xx, "BCM532xx LED Register Structure Diagrams"</li><li>• General: Low-power mode is not supported.</li></ul>
532XXXCT-DS3XX0-RI	04/30/08	Initial release

# Table of Contents

<b>About This Document</b> .....	32
Purpose and Audience .....	32
Acronyms and Abbreviations .....	32
Document Conventions .....	32
<b>Technical Support</b> .....	32
<b>Section 1: Introduction</b> .....	<b>34</b>
<b>Overview</b> .....	34
<b>Audience</b> .....	35
<b>Data Sheet Information</b> .....	35
<b>Section 2: Features and Operation</b> .....	<b>36</b>
<b>Overview</b> .....	36
<b>Quality of Service</b> .....	37
Egress Transmit Queues.....	37
Port-Based QoS.....	38
802.1p QoS.....	38
Protocol-Based QoS .....	39
MAC SA-Based QoS.....	39
DiffServ Based QoS .....	40
QoS Resolution Tree .....	40
Reason Code Based QoS .....	41
<b>Port-Based VLANs</b> .....	42
<b>802.1Q VLANs</b> .....	43
<b>MAC-based VLANs</b> .....	43
<b>Protocol-based VLANs</b> .....	43
<b>Flow-based VLANs</b> .....	43
<b>Customer-Tag-Based VLANs</b> .....	43
<b>Double Tagging</b> .....	45
NNI to NNI .....	45
UNI to NNI.....	47
NNI to UNI.....	48
<b>Link Aggregation</b> .....	51
<b>Rate Control</b> .....	52
Egress Rate Control.....	52
Ingress Rate Control: The Three-Bucket System.....	54

<b>Protected Ports</b> .....	54
<b>Port Mirroring</b> .....	55
Mirror Filtering Rules.....	55
Port Mask Filter.....	55
Packet Address Filter.....	55
Packet Divider Filter.....	56
<b>IGMP and MLD Snooping</b> .....	56
<b>Jumbo Frame Support</b> .....	56
<b>802.1x Port-Based Security</b> .....	56
<b>Dynamic Secure MAC Mode</b> .....	57
<b>Address Management</b> .....	57
Address Table Organization.....	57
Address Learning.....	58
Reserved Addresses.....	59
Learning.....	60
Static Address.....	60
Resolution.....	61
Hash Function.....	61
ARL Mishs Options.....	61
<b>Bridge Management</b> .....	63
Spanning Tree Port State.....	63
Disable.....	63
Blocking.....	63
Listening.....	64
Learning.....	64
Forwarding.....	64
Management Frames.....	65
<b>Compact Field Processor</b> .....	65
Parser.....	66
Lookup Engine.....	69
Policy Engine.....	73
Packet Remarking.....	73
VID Replacement.....	74
Metering Engine.....	74
Statistic Engine.....	74
ACL Action Resolution Block.....	74

**Section 3: System Functional Blocks ..... 75**

- Overview..... 75**
- Media Access Controller..... 75**
  - Receive Function.....75
  - Transmit Function .....76
  - Flow Control.....76
    - 10/100 Mbps Half-Duplex.....76
    - 10/100/1000 Mbps Full-Duplex.....76
- Integrated PHY.....77**
  - Encoder .....77
  - Decoder.....77
  - Link Monitor.....78
  - Digital Adaptive Equalizer .....78
  - Analog-to-Digital Converter .....78
  - Clock Recovery/Generator.....78
  - Baseline Wander Correction .....79
  - Multimode TX Digital-to-Analog Converter .....79
  - Stream Cipher .....79
  - Wire Map and Pair Skew Correction.....80
  - Internal Loopback Mode.....80
  - Isolate Mode .....80
  - PHY Registers .....80
  - 100Base-FX Fiber Mode .....80
  - Cable Analyzer Registers and Programming .....81
    - Shadow Register Description.....81
      - 0x26 Index [10:8] .....81
      - Pair-B State[13:12].....82
      - Pair-A State[11:10] .....82
      - Start [2].....82
      - MP [1] = 1 .....82
      - Pass [9:8] .....83
      - Error [7:6] .....83
      - Pair-B Length [15:8] .....83
      - Pair-A Length [7:0].....83
      - GainA [15:14] = 01b.....83
      - TypeA [11:10] = 10b.....84

HP [5] = 1 .....	84
ThresholdA [4:0] = 00100b .....	84
SourceA [13:8] = 00100000b .....	84
TypeB [10].....	84
TPG [8:6] .....	84
GainB [15:14 = 11b] .....	84
ThresholdB [4:2] = 001b .....	85
SourceB [13:8] = 000001b .....	85
PGWB [8:6] = 001b .....	85
AmpB [4:0] = 01100b .....	85
Programming Example .....	86
Cable Analyzer Flow Chart.....	87
<b>Frame Management</b> .....	<b>88</b>
In Band Management Port.....	88
IMP Ingress .....	89
IMP Egress .....	91
<b>Switch Controller</b> .....	<b>93</b>
Buffer Management.....	93
Memory Arbitration.....	93
Transmit Output Port Queues .....	93
<b>Integrated High-Performance Memory</b> .....	<b>94</b>
<b>Clocking</b> .....	<b>94</b>
<b>MIB Engine</b> .....	<b>94</b>
MIB Counters Per Port .....	94
Total Number of Counters Per Port: 35 .....	98
<b>Section 4: System Interfaces</b> .....	<b>102</b>
<b>Overview</b> .....	<b>102</b>
<b>MII Port</b> .....	<b>102</b>
Network Port .....	102
Reverse MII Port .....	103
Management Port (IMP).....	104
<b>GMII/RGMII/TBI Port</b> .....	<b>104</b>
GMII .....	104
RGMII .....	105
TBI .....	105
<b>10/100 Mbps Copper Interface</b> .....	<b>105</b>

Auto-Negotiation .....	106
Automatic MDI Crossover .....	106
10/100Base-T Forced Mode Auto-MDIX .....	106
<b>Configuration Pins .....</b>	<b>106</b>
<b>Programming Interfaces .....</b>	<b>107</b>
SPI Interface .....	107
Normal SPI Mode .....	108
<b>EEPROM Interface .....</b>	<b>112</b>
EEPROM Format .....	112
<b>MDC/MDIO Interface .....</b>	<b>114</b>
MDC/MDIO Master Interface .....	114
MDC/MDIO Slave Interface .....	114
Switch Register Access Through Pseudo-PHY Interface .....	114
MDC/MDIO Slave Interface Register Programming .....	115
Preamble (PRE) .....	115
Start of Frame (ST) .....	115
Operation Code (OP) .....	115
PHY Address (PHYAD) .....	115
Register Address (REGAD) .....	116
Turnaround (TA) .....	116
Data .....	116
Idle .....	116
<b>LED Interfaces .....</b>	<b>123</b>
Serial LED Interface .....	123
Programming LED Registers .....	127
<b>JTAG Interface .....</b>	<b>130</b>
<b>Internal Voltage Regulators .....</b>	<b>130</b>
<b>Section 5: BCM53242M Hardware Signal Definitions .....</b>	<b>132</b>
<b>Section 6: Pin Assignments .....</b>	<b>145</b>
Ball List by Signal Name .....	148
<b>Section 7: BCM53242M Ball Locations .....</b>	<b>151</b>
400-PBGA Ball Location Diagram .....	151
<b>Section 8: Register Definitions .....</b>	<b>152</b>
Register Notations .....	152
Register Definition .....	152



<b>Page 00h: Control Registers</b> .....	155
Switch Mode Register (Page 00h/Addr 00h).....	156
PHY Scan Control Register (Page 00h/Addr 02h).....	156
New Control Register (Page 00h/Addr 03h) .....	157
Broadcast Forward Map Register (Page 00h/Addr 20h).....	158
IPMC Lookup Fail Forward Map Register (Page 00h/Addr 28h) .....	159
Unicast Lookup Fail Forward Map Register (Page 00h/Addr 30h).....	159
Multicast Lookup Fail Forward Map Register (Page 00h/Addr 38h).....	160
Protected Port Select Register (Page 00h/Addr 40h) .....	161
Software Flow Control Registers (Page 00h/Addr 48h) .....	162
Strap Pins Status Register (Page 00h/Addr 50h).....	163
LED Control Register (Page 00h/Addr 5Ah) .....	164
LED Function 0 Control Register (Page 00h/Addr 5Ch–5Dh) .....	166
LED Function 1 Control Register (Page 00h/Addr 5Eh–5Fh).....	166
LED Function Map Register (Page 00h/Addr 60h–67h) .....	168
LED Enable Map Register (Page 00h/Addr 68h–6Fh).....	169
LED Mode Map 0 Register (Page 00h/Addr 70h–77h).....	170
LED Mode Map 1 Register (Page 00h/Addr 78h–7Fh).....	171
RX PAUSE PASS Register (Page 00h/Addr 90h–97h).....	172
TX PAUSE PASS Register (Page 00h/Addr 98h–9Fh) .....	173
TCAM BIST Control Register (Page 00h/Addr B8h).....	173
Configuration ID Register (Page 00h/Addr EEh) .....	173
<b>Page 01h: Control 1 Registers</b> .....	174
GigaPort G0 RGMII Timing Delay Register (Page 01h/Addr 00h).....	175
GigaPort G1 RGMII Timing Delay Register (Page 01h/Addr 01h).....	175
GigaPort G0 RGMII Control Register (Page 01h/Addr 02h) .....	176
GigaPort G1 RGMII Control Register (Page 01h/Addr 03h) .....	176
MII Port 0–23 State Override Registers (Page 01h/Addr 28h–3Fh).....	176
MII Port State Override Register.....	177
IMP/MII Port State Override Registers (Page 01h/Addr 40h).....	178
GigaPort State Override Registers (Page 01h/Addr 41-42h).....	178
IMP Port PHY Scan Result Registers (Page 01H/Addr 68h).....	179
G0–G1 GigaPorts PHY Scan Result Registers (Page 01h/Addr 69h–70h).....	180
10/100 Ports 0–23 Control Registers (Page 01h/Addr 88h–9Fh) .....	181
IMP Port Control Register (Page 01h/Addr A0h) .....	183
GigaPorts G0-G1 Control Registers (Page 01h/Addr A1h–A2h).....	184
Status Control Register (Page 01h/Addr B0h).....	185

<b>Page 02h: Status Registers</b> .....	186
BIST Status 0 Register (Page 02h/Addr 00h–07h) .....	187
BIST Status 1 Register (Page 02h/Addr 08h–0Fh) .....	188
Link Status Summary Register (Page 02h/Addr 10h–17h) .....	189
Link Status Change Register (Page 02h/Addr 18h–1Fh) .....	190
Port Speed Summary Register (Page 02h/Addr 20h–27h) .....	191
Duplex Status Summary Register (Page 02h/Addr 28h–2Fh) .....	192
Pause Status Summary Register (Page 02h/Addr 30h–37h) .....	193
<b>Page 03h: Management Mode Registers</b> .....	193
Global Management Configuration Register (Page 03h/Addr 00h) .....	195
Table Memory Reset Control Register (Page 03h/Addr 01h) .....	195
Management Port ID Register (Page 03h/Addr 02h) .....	196
Reset Table Memory Register (Page 03h: Address 03h) .....	197
Aging Time Control Register (Page 03h/Addr 04h–07h) .....	197
RMON MIB Steering Register (Page 03h/Addr 08h–0Fh) .....	198
Mirror Capture Control Register (Page 03h/Addr 10h–17h) .....	199
Ingress Mirror Control Register (Page 03h/Addr 18h–1Fh) .....	200
Ingress Mirror Divider Register (Page 03h/Addr 20h–21h) .....	200
Ingress Mirror MAC Address Register (Page 03h/Addr 22h–27h) .....	201
Egress Mirror Control Register (Page 03h/Addr 28h–2Fh) .....	202
Egress Mirror Divider Register (Page 03h/Addr 30h–31h) .....	203
Egress Mirror MAC Address Register (Page 03h/Addr 32h–37h) .....	203
Special Management Control Register (Page 03h/Addr 40h) .....	204
MIB Snapshot Control Register (Page 03h/Addr 50h) .....	205
Ingress RMON Register (Page 03h/Addr 60h–67h) .....	206
Egress RMON Register (Page 03h/Addr 68h–69h) .....	207
Chip Reset Control Register (Page 03h/Addr 7Ch) .....	207
<b>Page 04h: ARL Control Register</b> .....	208
Global ARL Configuration Register (Page 04h/Addr 00h) .....	208
BPDU Multicast Address Register (Page 04h/Addr 04h–09h) .....	209
Multiport Address 1 Register (Page 04h/Addr 10h–15h) .....	209
Multiport Vector 1 Register (Page 04h/Addr 18h–1Fh) .....	210
Multiport Address 2 Register (Page 04h/Addr 20h–25h) .....	210
Multiport Vector 2 Register (Page 04h/Addr 28h–2Fh) .....	210
<b>Page 05h: ARL Access Registers</b> .....	211
ARL Read/Write Control Register (Page 05h/Addr 00h) .....	213

MAC Address Index Register (Page 05h/Addr 02h–07h) .....	213
VID Table Index Register (Page 05h/Addr 08h–09h) .....	214
ARL Entry 0 Register, for Unicast Address (Page 05h/Addr 10h–17h).....	214
ARL Entry 0 Register, for Multicast Address (Page 05h/Addr 10h–17h).....	215
ARL Entry 1 Register, for Unicast Address (Page 05h/Addr 18h–1Fh).....	217
ARL Entry 1 Register, for Multicast Address (Page 05h/Addr 18h–1Fh).....	218
VID Entry 0 Register (Page 05h/Addr 20h–21h).....	218
VID Entry 1 Register (Page 05h/Addr 28h–29h).....	219
Multitable Index Register (Page 05h/Addr 30h–31h) .....	219
Multitable Data 0 Register (Page 05h/Addr 38h–3Fh).....	221
Multitable Data 1 Register (Page 05h/Addr 40h–47h) .....	222
Multitable Data 2 Register (Page 05h/Addr 48h–4Fh).....	225
ARL Search Control Register (Page 05h/Addr 50h).....	226
ARL Search Address Register (Page 05h/Addr 52h–53h).....	226
ARL Search Result MAC Register (Page 05h/Addr 54h–5Bh).....	227
ARL Search Result VID Register (Page 05h/Addr 5Ch–5Dh).....	228
<b>Page 0Ah: Priority Queue Control Registers</b> .....	229
Flow Control Diagnostic Register (Page 0Ah/Addr 00h–01h).....	232
Queue 0 100 TX Threshold Control 1 Register (Page 0Ah/Addr 06h–07h).....	232
Queue 0 100 TX Threshold Control 2 Register (Page 0Ah/Addr 08h–09h).....	233
Global Threshold Control 1 Register (Page 0Ah/Addr 0Eh–0Fh) .....	233
Global Threshold Control 2 Register (Page 0Ah/Addr 10h–11h).....	234
Transmit Queue Threshold Control Register (Page 0Ah/Addr 12h–13h) .....	234
Flow Control Status 2 Register (Page 0Ah/Addr 1Ch–1Dh).....	235
Flow Control Status 3 Register (Page 0Ah/Addr 1Eh–1Fh).....	235
Flow Control Status 4 Register (Page 0Ah/Addr 20h–21h).....	235
Flow Control Status 5 Register (Page 0Ah/Addr 22h–23h).....	236
Flow Control Status 7 Register (Page 0Ah/Addr 26h–27h).....	236
Flow Control Status 9 Register (Page 0Ah/Addr 2Ah–2Bh) .....	236
Flow Control Status 10 Register (Page 0Ah/Addr 2Ch–2Dh) .....	237
Flow Control Status 11 Register (Page 0Ah/Addr 2Eh–2Fh).....	237
Global Option Control Register (Page 0Ah/Addr 30h–31h).....	237
CPU/MII Threshold Control Register (Page 0Ah/Addr 32h–33h) .....	238
Pre-Queue TX Drop Control Register (Page 0Ah/Addr 34h–35h).....	239
MON Flow Control Reg Bus Register (Page 0Ah/Addr 36h–37h) .....	239
Flow Control Status 12 Register (Page 0Ah/Addr 3Ch–3Dh).....	239
Misc TX Flow Control Register (Page 0Ah/Addr 4Ah–4Bh).....	239

Queue Congestion Status 0 Register (Page 0Ah/Addr 50h-51h) .....	240
Queue Congestion Status 1 Register (Page 0Ah/Addr 52h-53h) .....	240
Queue Congestion Status 2 Register (Page 0Ah/Addr 54h-55h) .....	240
Queue Congestion Status 3 Register (Page 0Ah/Addr 58h-59h) .....	240
Queue Congestion Status 4 Register (Page 0Ah/Addr 5Ah-5Bh) .....	241
Queue Congestion Status 5 Register (Page 0Ah/Addr 5Ch-5Dh) .....	241
Queue 0 TxDsc Control Register (Page 0Ah/Addr 64h-65h) .....	241
Queue 1 100BT Threshold Control 1 Register (Page 0Ah/Addr 6Ah-6Bh) .....	242
Queue 1 100BT Threshold Control 2 Register (Page 0Ah/Addr 6Ch-6Dh) .....	242
Queue 1 TxDsc Control Register (Page 0Ah/Addr 72h-73h) .....	243
Queue 2 100TX Threshold Control 1 Register (Page 0Ah/Addr 78h-79h) .....	243
Queue 2 100TX Threshold Control 2 Register (Page 0Ah/Addr 7Ah-7Bh) .....	244
Queue 2 TxDsc Control Register (Page 0Ah/Addr 80h-81h) .....	244
Queue 3 100TX Threshold Control 1 Register (Page 0Ah/Addr 86h-87h) .....	245
Queue 3 100TX Threshold Control 2 Register (Page 0Ah/Addr 88h-89h) .....	245
RX Base Buffer Number Register (Page 0Ah/Addr 8Ah-8Bh) .....	246
Queue 3 TxDsc Control Register (Page 0Ah/Addr 8Eh-8Fh) .....	246
Reserved Buffer Number Register (Page 0Ah/Addr 90h-91h) .....	246
Received Base Flow Control Register (Page 0Ah/Addr 92h-93h) .....	247
DLF Threshold Drop Register (Page 0Ah/Addr 94h-95h) .....	247
Broadcast Threshold Drop Register (Page 0Ah/Addr 96h-97h) .....	248
LAN to IMP Unicast Control Register (Page 0Ah/Addr A0h-A1h) .....	248
LAN to IMP Multicast Control 1 Register (Page 0Ah/Addr A2h-A3h) .....	249
LAN to IMP Multicast Control 2 Register (Page 0Ah/Addr A4h-A5h) .....	249
IMP to LAN Control 1 Register (Page 0Ah/Addr B0h-B1h) .....	249
IMP to LAN Control 2 Register (Page 0Ah/Addr B2h-B3h) .....	249
Queue 1 Total Threshold Control 1 Register (Page 0Ah/Addr C0h-C1h) .....	250
Queue 1 Total Threshold Control 2 Register (Page 0Ah/Addr C2h-C3h) .....	250
Queue 2 Total Threshold Control 1 Register (Page 0Ah/Addr C4h-C5h) .....	250
Queue 2 Total Threshold Control 2 Register (Page 0Ah/Addr C6h-C7h) .....	250
Queue 3 Total Threshold Control 1 Register (Page 0Ah/Addr C8h-C9h) .....	250
Queue 3 Total Threshold Control 2 Register (Page 0Ah/Addr CAh-CBh) .....	251
Queue 1 Total BC/DLF Drop Threshold Control Register (Page 0Ah/Addr D0h-D1h) .....	251
Queue 2 Total BC/DLF Drop Threshold Control Register (Page 0Ah/Addr D2h-D3h) .....	251
Queue 3 Total BC/DLF Drop Threshold Control Register (Page 0Ah/Addr D4h-D5h) .....	251
<b>Page 0Dh: TBI Registers</b> .....	<b>253</b>

TBI Control Register (Page 0Dh/Addr 00h–01h) .....	253
PRBS Control Register (Page 0Dh/Addr 02h) .....	254
PRBS Status Register (Page 0Dh/Addr 03h–06h) .....	255
MR Status Register (Page 0Dh/Addr 07h) .....	256
SGMII Clear Control Register (Page 0Dh/Addr 08h) .....	256
Gigabit Port SGMII Control Register (Page 0Dh/Addr 50h–53h) .....	257
Gigabit Port SGMII Status Register (Page 0Dh/Addr 54h–57h) .....	258
Gigabit Port Link Partner Link Status Register (Page 0Dh/Addr 58h–5Bh) .....	258
Gigabit Port CRC16 Register (Page 0Dh/Addr 5Ch–5Fh) .....	258
<b>Page 10h: PHY Info Registers</b> .....	259
PHY ID High Register (Page 10h/Addr 04h) .....	259
PHY ID Low Register (Page 10h/Addr 06h) .....	259
<b>Page 20h: CFP Registers</b> .....	260
CFP Access Register (Page 20h/Addr 00h–03h) .....	262
CFP TCAM Data 0 Register (Page 20h/Addr 10h–17h) .....	262
CFP TCAM Data 1 Register (Page 20h/Addr 18h–1Fh) .....	263
CFP TCAM Data 2 Register (Page 20h/Addr 20h–27h) .....	263
CFP TCAM Data 3 Register (Page 20h/Addr 28h–2Fh) .....	263
CFP TCAM Data 4 Register (Page 20h/Addr 30h–37h) .....	263
CFP TCAM Data 5 Register (Page 20h/Addr 38h–3Fh) .....	264
CFP TCAM Mask 0 Register (Page 20h/Addr 40h–47h) .....	264
CFP TCAM Mask 1 Register (Page 20h/Addr 48h–4Fh) .....	264
CFP TCAM Mask 2 Register (Page 20h/Addr 50h–57h) .....	264
CFP TCAM Mask 3 Register (Page 20h/Addr 58h–5Fh) .....	265
CFP TCAM Mask 4 Register (Page 20h/Addr 60h–67h) .....	265
CFP TCAM Mask 5 Register (Page 20h/Addr 68h–6Fh) .....	265
CFP Action Policy Data Register (Page 20h/Addr 70h–75h) .....	265
CFP Rate Meter Configuration Register (Page 20h/Addr 80h–83h) .....	270
CFP Rate Inband Statistic Register (Page 20h/Addr 90h–93h) .....	270
CFP Rate Outband Statistic Register (Page 20h/Addr 94h–97h) .....	270
<b>Page 21h: CFP Control Registers</b> .....	271
CFP Global Control Register (Page 21h/Addr 00h) .....	272
Range Checker Control Register (Page 21h/Addr 08h) .....	272
Global CFP Control1 Register (Page 21h/Addr 10h) .....	274
CFP Enable Control Register (Page 21h/Addr 20h–27h) .....	274
VID Range Checker 0 Register (Page 21h/Addr 30h) .....	274
VID Range Checker 1 Register (Page 21h/Addr 34h) .....	274

VID Range Checker 2 Register (Page 21h/Addr 38h) .....	275
VID Range Checker 3 Register (Page 21h/Addr 3Ch) .....	275
L4 Port Range Checker 0 Register (Page 21h/Addr 40h).....	275
L4 Port Range Checker 1 Register (Page 21h/Addr 44h).....	275
L4 Port Range Checker 2 Register (Page 21h/Addr 48h).....	275
L4 Port Range Checker 3 Register (Page 21h/Addr 4Ch) .....	276
Other Checker Register (Page 21h/Addr 50h) .....	276
<b>Page 22h: CFP UDF Control Registers</b> .....	276
CFP UDF A0 Control Register (Page 22h/Addr 00h).....	278
CFP UDF A1 Control Register (Page 22h/Addr 01h).....	278
CFP UDF A2 Control Register (Page 22h/Addr 02h).....	278
CFP UDF B0 Control Register (Page 22h/Addr 10h).....	279
CFP UDF B1 Control Register (Page 22h/Addr 11h).....	279
CFP UDF B2 Control Register (Page 22h/Addr 12h).....	279
CFP UDF B3 Control Register (Page 22h/Addr 13h).....	280
CFP UDF B4 Control Register (Page 22h/Addr 14h).....	280
CFP UDF B5 Control Register (Page 22h/Addr 15h).....	281
CFP UDF B6 Control Register (Page 22h/Addr 16h).....	281
CFP UDF B7 Control Register (Page 22h/Addr 17h).....	281
CFP UDF B8 Control Register (Page 22h/Addr 18h).....	282
CFP UDF B9 Control Register (Page 22h/Addr 19h).....	282
CFP UDF B10 Control Register (Page 22h/Addr 1Ah).....	283
CFP UDF C0 Control Register (Page 22h/Addr 20h).....	283
CFP UDF C1 Control Register (Page 22h/Addr 21h).....	283
CFP UDF C2 Control Register (Page 22h/Addr 22h).....	284
CFP UDF D0 Control Register (Page 22h/Addr 30h).....	284
CFP UDF D1 Control Register (Page 22h/Addr 31h).....	285
CFP UDF D2 Control Register (Page 22h/Addr 32h).....	285
CFP UDF D3 Control Register (Page 22h/Addr 33h).....	285
CFP UDF D4 Control Register (Page 22h/Addr 34h).....	286
CFP UDF D5 Control Register (Page 22h/Addr 35h).....	286
CFP UDF D6 Control Register (Page 22h/Addr 36h).....	287
CFP UDF D7 Control Register (Page 22h/Addr 37h).....	287
<b>Page 30h: QoS Registers</b> .....	288
QoS Control Register (Page 30h/Addr 10h–17h) .....	289
QoS 802.1p Enable Register (Page 30h/Addr 18h–1Fh) .....	290

QoS DiffServ Enable Register (Page 30h/Addr 20h–27h).....	291
QoS Pause Enable Register (Page 30h/Addr 28h–2Fh).....	292
Priority Threshold Register (Page 30h/Addr 30h–31h).....	292
DiffServ DSCP Priority Register (Page 30h/Addr 40h–4Fh).....	293
QoS Reason Code Enable Register (Page 30h/Addr 58h–59h).....	293
<b>Page 31h: MAC-Based Aggregation Registers</b> .....	295
Global Aggregation Control Register (Page 31h/Addr 00h).....	296
Aggregation Control Group n Register (Page 31h/Addr 10h–7Fh).....	297
<b>Page 33h: Port Egress Control Registers</b> .....	298
Port Egress Control Register (Page 33h/Addr 00h–D7h).....	299
<b>Page 34h: 802.1Q VLAN Registers</b> .....	300
802.1Q Control 0 Register (Page 34h/Addr 00h).....	301
802.1Q Control 1 Register (Page 34h/Addr 01h).....	301
802.1Q Control 2 Register (Page 34h/Addr 02h).....	304
802.1Q Control 3 Register (Page 34h/Addr 08h–0Fh).....	305
802.1Q Control 4 Register (Page 34h/Addr 03h).....	306
802.1Q Control 5 Register (Page 34h/Addr 04h).....	307
802.1Q Default Port Tag Register (Page 34h/Addr 40h–75h).....	308
Global Double Tagging Control Register (Page 34h/Addr 90h).....	309
SP Portmap Selection Register (Page 34h/Addr 98h–9Fh).....	311
VLAN to VLAN Control Register (Page 34h/Addr A0h–A7h).....	312
MAC to VLAN Control Register (Page 34h/Addr A8h–AFh).....	313
Protocol to VLAN Control Register (Page 34h/Addr B0h–B7h).....	314
Trusted Customer VLAN Register (Page 34h: Address B8h–BFh).....	315
<b>Page 40h: 802.1x Registers</b> .....	316
Port EAP Configuration Register (Page 40h/Addr 00h–1Ah).....	317
Port EAP Destination Address Register (Page 40h/Addr 20h–BCh).....	320
<b>Page 41h: 802.1x_1 Registers</b> .....	322
EAP Destination IP Register 0 (Page 41h/Addr 00h–07h).....	322
EAP Destination IP Register 1 (Page 41h/Addr 08h–0Fh).....	322
EAP Global Configuration Register (Page 41h/Addr 10h–11h).....	322
Learning Counter Control Register (Page 41h/Addr 18h–19h).....	323
Port Max Learn Register (Page 41h/Addr 20h–5Fh).....	325
Port SA Count Register (Page 41h/Addr 60h–98h).....	326
<b>Page 43h: Rate Control Registers</b> .....	328
Rate Control Memory Access Register (Page 43h/Addr 00h).....	328
Rate Control Memory Port Register (Page 43h/Addr 01h).....	329

Rate Control Memory Data Register 0 (Page 43h/Addr 10h–13h) .....	330
Rate Control Memory Data Register 1 (Page 43h/Addr 14h–17h) .....	331
Rate Control Memory Data Register 2 (Page 43h/Addr 18h–1Bh) .....	332
Rate Control Memory Data Register 3 (Page 43h/Addr 1Ch–1Fh) .....	333
Rate Control Memory Data Register 4 (Page 43h/Addr 20h–23h) .....	333
<b>Page 45h: 802.1s Multiple Spanning Tree Registers</b> .....	334
MST Control Register (Page 45h/Addr 00h).....	334
Age-out Control Register (Page 45h/Addr 04h–07h).....	335
<b>Page 68h–84h: Port MIB Registers</b> .....	336
<b>Page 85h: Snapshot Port MIB Registers</b> .....	338
<b>Page A0h–B7h: FE Ports 0-23 MII Registers</b> .....	340
MII Control Register (Page A0h–B7h/Addr 00h–01h).....	342
Reset .....	342
Loopback.....	342
Forced Speed Selection .....	343
Auto-Negotiation Enable .....	343
Power Down .....	343
Isolate .....	343
Restart Auto-Negotiation .....	343
Duplex Mode .....	343
Reserved Bits .....	343
MII Status Register (Page A0h–B7h/Addr 02h–03h).....	344
100Base-T4 Capability .....	344
100Base-X Full-Duplex Capability .....	344
100Base-X Half-Duplex Capability .....	344
10Base-T Full-Duplex Capability .....	345
10Base-T Half-Duplex Capability.....	345
Reserved Bit.....	345
MF Preamble Suppression.....	345
Auto-Negotiation Complete .....	345
Remote Fault .....	345
Auto-Negotiation Capability .....	345
Link Status.....	345
Jabber Detect.....	346
Extended Capability.....	346



PHY Identifier Registers (Page A0h–B7h/Addr 04h–07h) .....	347
Auto-Negotiation Advertisement Register (Page A0h–B7h/Addr 08h–09h) .....	347
Next Page.....	347
Remote Fault .....	347
Reserved Bits .....	348
Pause Operation for Full-Duplex Links.....	348
Advertisement Bits .....	348
Selector Field .....	348
Auto-Negotiation Link Partner Ability Register (Page A0h–B7h/Addr 0Ah–0Bh) .....	348
Next Page.....	349
Acknowledge .....	349
Remote Fault .....	349
Reserved Bits .....	349
Pause .....	349
Advertisement Bits .....	349
Selector Field .....	349
Auto-Negotiation Expansion Register (Page A0h–B7h/Addr 0Ch–0Dh) .....	349
Parallel Detection Fault .....	350
Link Partner Next Page Able .....	350
Page Received.....	350
Link Partner Auto-Negotiation Able .....	350
Auto-Negotiation Next Page Register (Page A0h–B7h/Addr 0Eh–0Fh) .....	351
Next Page.....	351
Message Page .....	351
Acknowledge 2 .....	351
Toggle .....	351
Message Code Field.....	351
Unformatted Code Field .....	351
Link Partner Next Page Register (Page A0h–B7h/Addr 10h–11h) .....	352
Next Page.....	352
Message Page .....	352
Acknowledge 2 .....	352
Toggle .....	352
Message Code Field.....	352
Unformatted Code Field .....	352

<b>Page D8h–DAh: External PHY Registers</b> .....	353
<b>Global Registers</b> .....	355
SPI Data I/O Register.....	355
SPI Status Register.....	355
Page Register.....	356
<b>Section 9: Electrical Characteristics</b> .....	<b>357</b>
<b>Absolute Maximum Ratings</b> .....	357
<b>Recommended Operating Conditions</b> .....	357
<b>Electrical Characteristics</b> .....	358
<b>Section 10: BCM53242M Timing Characteristics</b> .....	<b>360</b>
<b>Reset and Clock Timing</b> .....	360
<b>LED Timing</b> .....	361
<b>MII Input Timing</b> .....	362
<b>RvMII Input Timing</b> .....	363
<b>MII Output Timing</b> .....	364
<b>RvMII Output Timing</b> .....	365
<b>RGMIID Interface Timing</b> .....	366
RGMIID Output Timing (Normal Mode).....	366
RGMIID Output Timing (Delayed Mode Clock).....	367
RGMIID Input Timing (Normal Mode).....	368
RGMIID Input Timing (Delayed Mode Clock).....	369
<b>GMII Interface Timing</b> .....	370
GMII Interface Output Timing.....	370
GMII Interface Input Timing.....	371
<b>TBI Interface Timing</b> .....	372
TBI Interface Output Timing.....	372
TBI Interface Input Timing.....	372
<b>SPI Timing</b> .....	374
<b>EEPROM Timing</b> .....	376
<b>Management Data Interface</b> .....	376
<b>Section 11: Thermal Characteristics</b> .....	<b>378</b>
<b>Section 12: Mechanical Information</b> .....	<b>379</b>
<b>Section 13: Ordering Information</b> .....	<b>381</b>

## List of Figures

Figure 1: Functional Block Diagram .....	2
Figure 2: Shaping-Scheduling Structure of Each Egress port.....	38
Figure 3: First Level QoS Resolution Tree.....	40
Figure 4: Final level QoS Resolution Tree .....	42
Figure 5: VLAN Resolution Tree.....	44
Figure 6: NNI to NNI Tag Handling .....	46
Figure 7: UNI to NNI .....	47
Figure 8: NNI to UNI .....	48
Figure 9: UNI to UNI .....	49
Figure 10: Non_Double Tagging Mode UNI to UNI .....	50
Figure 11: Link Aggregation.....	51
Figure 12: Ingress Bucket Flow.....	53
Figure 13: Mirror Filter Flow .....	55
Figure 14: BCM53242M Address Table Organization.....	58
Figure 15: CFP Engines .....	66
Figure 16: Standard Packet Format.....	69
Figure 17: Cable Analyzer Flow Chart.....	87
Figure 18: Broadcom-Tagged Packet Encapsulation Format.....	89
Figure 19: MAC-to-MAC MII Connection.....	104
Figure 20: SPI Serial Interface Write Operation .....	108
Figure 21: SPI Serial Interface Read Operation .....	108
Figure 22: Normal SPI Mode Read Flow Chrt .....	110
Figure 23: Normal SPI Mode Write Flow Chart .....	111
Figure 24: Serial EEPROM Connection .....	112
Figure 25: Pseudo PHY MII Register Definitions.....	117
Figure 26: Pseudo PHY MII Register 16: Register Set Access Control Bit Definition .....	118
Figure 27: Pseudo PHY MII Register 17: Register Set Read/Write Control Bit Definition .....	118
Figure 28: Pseudo PHY MII Register 18: Register Access Status Bit Definition .....	118
Figure 29: Pseudo PHY MII Register 24: Access Register Bit Definition .....	119
Figure 30: Pseudo PHY MII Register 25: Access Register Bit Definition .....	119
Figure 31: Pseudo PHY MII Register 26: Access Register Bit Definition .....	119
Figure 32: Pseudo PHY MII Register 27: Access Register Bit Definition .....	120
Figure 33: Read Access to the Register Set Via the Pseudo PHY (Phyad = 11110) MDC/MDIO Path.....	121
Figure 34: Write Access to the Register Set Via the Pseudo PHY (Phyad = 11110) MDC/MDIO Path.....	122
Figure 35: Serial LED Shift Sequence LEDMODE[2:0] = '000' .....	124

Figure 36: Bicolor LINK/ACT LED Scheme .....	125
Figure 37: BCM53242 LED Register Structure Diagram.....	128
Figure 38: Partial Example External Circuit for Serial LED Mode (LEDMODE[2:0]='000') .....	129
Figure 39: External PNP for 1.2V Voltage Regulators.....	131
Figure 40: External PNP for 2.5V Voltage Regulators.....	131
Figure 41: 400-PBGA Ball Location Diagram (Top View) .....	151
Figure 42: Reset and Clock Timing .....	360
Figure 43: Serial LED Timing .....	361
Figure 44: MII Input Timing .....	362
Figure 45: RvMII Input Timing .....	363
Figure 46: MII Output Timing .....	364
Figure 47: RvMII Output Timing .....	365
Figure 48: RGMII Output Timing (Normal Mode).....	366
Figure 49: RGMII Output Timing (Delayed Mode Clock) .....	367
Figure 50: RGMII Input Timing (Normal Mode).....	368
Figure 51: RGMII Input Timing (Delayed Mode Clock) .....	369
Figure 52: GMII Output Timing.....	370
Figure 53: GMII Input Timing.....	371
Figure 54: TBI Output Timing .....	372
Figure 55: TBI Input Timing .....	372
Figure 56: SPI Timing, $\overline{SS}$ Asserted During SCK High.....	374
Figure 57: SPI Timing, $\overline{SS}$ Asserted During SCK Low .....	374
Figure 58: EEPROM Timing.....	376
Figure 59: Management Data Interface .....	376
Figure 60: 400-PBGA Package Outline Drawing .....	380

## List of Tables

Table 1: Reasons and QoS for CPU Traffic .....	41
Table 2: Behavior for Reserved Multicast Addresses .....	59
Table 3: Spanning Tree State .....	64
Table 4: Slice Key Common Fields .....	70
Table 5: Slice 0 Key Field Definition .....	70
Table 6: Slice 1 Key Field Definition .....	72
Table 7: Slice 2 Key Field Definition .....	72
Table 8: Flow Control Modes .....	77
Table 9: Shadow Register 28h (Pages A0h-B7h, Address 28h) .....	81
Table 10: Shadow Register 0x26-0 (Pages A0h-B7h, Address 26h) .....	81
Table 11: Pair-B State .....	82
Table 12: Pair-A State .....	82
Table 13: Shadow Register 0x26-1 (Pages A0h-B7h, Address 26h) .....	83
Table 14: Pair-B Cable Diagnostics Result .....	83
Table 15: Pair-A Cable Diagnostics Result .....	83
Table 16: Shadow Register 0x26-2 (Pages A0h-B7h, Address 26h) .....	83
Table 17: Shadow Register 0x26-3 (Pages A0h-B7h, Address 26h) .....	84
Table 18: Shadow Register 0x26-4 S (Pages A0h-B7h, Address 26h) .....	84
Table 19: Shadow Register 0x26-5 (Pages A0h-B7h, Address 26h) .....	84
Table 20: Shadow Register 0x26-6 (Pages A0h-B7h, Address 26h) .....	85
Table 21: Shadow Register 0x26-7 (Pages A0h-B7h, Address 26h) .....	85
Table 22: BRCM Header Tag Format (CPU to IMP).....	90
Table 23: OPCODE Field in BRCM Tag for Management Port Frame .....	90
Table 24: TQ and TE Fields in BRCM Tag for Management Port Frame .....	91
Table 25: BRCM Header Tag Format (IMP to CPU).....	91
Table 26: OPCODE Field in BRCM Tag for Management Port Frame .....	91
Table 27: Reason Code Field in BRCM Tag for Management Port Frame .....	92
Table 28: Receive Only Counters (17) .....	94
Table 29: Transmit Counters Only (21).....	96
Table 30: Transmit or Receive Counters (6) .....	97
Table 31: Directly Supported MIB Counters .....	98
Table 32: Indirectly Supported MIB Counters .....	100
Table 33: Supported MIB Extensions .....	100
Table 34: MII/GMII/RGMII/TBI Mapping.....	105
Table 35: Normal SPI Command Byte.....	107

Table 36: EEPROM Header Format.....	113
Table 37: MII Management Frame Format .....	115
Table 38: Valid Serial LED Bit Stream Port Map .....	123
Table 39: LED Status Types.....	124
Table 40: Serial LED Mode Matrix Shift Sequence .....	125
Table 41: BCM53242M Legacy LED Shift Sequence Register Programming .....	127
Table 42: I/O Signal Type Definitions .....	132
Table 43: Hardware Signal Definitions .....	132
Table 44: Pin Assignment (Sorted by Ball Number) .....	145
Table 45: Pin Assignment (Sorted by Signal Name).....	148
Table 46: Valid Port Map and Feature Difference.....	152
Table 47: Global Page Register Map.....	153
Table 48: Control Registers (Page 00h) .....	155
Table 49: Switch Mode Register (Page 00h: Address 00h).....	156
Table 50: PHY Scan Control Register (Page 00h: Address 02h) .....	156
Table 51: New Control Register (Page 00h: Address 03h).....	157
Table 52: BCAST Forward Map Register (Page 00h: Address 20h).....	158
Table 53: IPMC Lookup Fail Forward Map Register (Page 00h: Address 28h).....	159
Table 54: UC Lookup Fail Forward Map Register (Page 00h: Address 30h) .....	159
Table 55: MC Lookup Fail Forward Map Register (Page 00h: Address 38h).....	160
Table 56: Protected Port Select Register (Page 00h: Address 40h).....	161
Table 57: Software Flow Control Register (Page 00h: Address 48h).....	162
Table 58: Strap Pins Status Register (Page 00h: Address 50h) .....	163
Table 59: LED Control Register (Page 00h: Address 5Ah).....	164
Table 60: LED Function 0 Control Register (Page 00h: Address 5Ch–5Dh) .....	166
Table 61: LED Function 1 Control Register (Page 00h: Address 5Eh–5Fh) .....	167
Table 62: LED Function Map Register (Page 00h: Address 60h–67h).....	168
Table 63: LED Enable Map Register (Page 00h: Address 68h–6Fh).....	169
Table 64: LED Mode Map 0 Register (Page 00h: Address 70h–77h) .....	170
Table 65: LED Mode Map 1 Register (Page 00h: Address 78h–7Fh) .....	171
Table 66: RX Pause Pass Register (Page 00h: Address 90h–97h) .....	172
Table 67: TX Pause Pass Register (Page 00h: Address 98h–9Fh).....	173
Table 68: MDIO Base Address Register (Page 00h: Address B8h).....	173
Table 69: Configuration ID Register (Page 00h/Addr EEh) .....	173
Table 70: Control 1 Registers (Page 01h) .....	174
Table 71: GigaPort G0 RGMII Timing Delay Register (Page 01h: Address 00h).....	175

Table 72: GigaPort G1 RGMII Timing Delay Register (Page 01h: Address 01h).....	175
Table 73: GigaPort G0 RGMII Control Register (Page 01h: Address 02h).....	176
Table 74: GigaPort G1 RGMII Control Register (Page 01h: Address 03h).....	176
Table 75: MII Port 0–23 State Override Registers (Page 01h/Addr 28h–3Fh).....	176
Table 76: MII Port State Override Register .....	177
Table 77: IMP Port State Override Registers (Page 01h/Addr 40h) .....	178
Table 78: GigaPort State Override Registers (Page 01h/Addr 41-42h) .....	178
Table 79: MII GigaPort State Override Registers.....	178
Table 80: IMP Port PHY Scan Result Registers (Page 01H/Addr 68h).....	179
Table 81: G0–G1 GigaPorts PHY Scan Result Registers (Page 01h/Addr 69h–70h).....	180
Table 82: GigaPorts PHY Scan Result Registers .....	180
Table 83: 10/100 Ports 0-23 Control Registers (Page 01h/Addr 88h–9Fh) .....	181
Table 84: 10/100 Ports Control Registers.....	182
Table 85: IMP Port Control Register (Page 01h: Address A0h).....	183
Table 86: GigaPorts G0-G1 Control Registers (Page 01h/Addr A1h–A2h).....	184
Table 87: GigaPorts Control Registers.....	184
Table 88: Status Control Register (Page 01h: Address B0h).....	185
Table 89: Status Registers (Page 02h) .....	186
Table 90: BIST Status 0 Register (Page 02h/Addr 00h–07h).....	187
Table 91: BIST Status 1 Register (Page 02h/Addr 08h–0Fh).....	188
Table 92: Link Status Summary Register (Page 02h: Address 10h–17h) .....	189
Table 93: Link Status Change Register (Page 02h: Address 18h–1Fh).....	190
Table 94: Port Speed Summary Register (Page 02h: Address 20h–27h).....	191
Table 95: Duplex Status Summary Register (Page 02h: Address 28h–2Fh).....	192
Table 96: Pause Status Summary Register (Page 02h: Address 30h–37h) .....	193
Table 97: Management Mode Registers (Page 03h) .....	193
Table 98: Global Management Configuration Register (Page 03h: Address 00h).....	195
Table 99: Table Memory Reset Control Register (Page 03h/Addr 01h) .....	195
Table 100: Management Port ID Register (Page 03h: Address 02h) .....	196
Table 101: Reset Table Memory Register (Page 03h: Address 03h).....	197
Table 102: Aging Time Control Register (Page 03h: Address 04h–07h) .....	197
Table 103: RMON MIB Steering Register (Page 03h: Address 08h–0Fh).....	198
Table 104: Mirror Capture Control Register (Page 03h: Address 10h–17h).....	199
Table 105: Ingress Mirror Control Register (Page 03h: Address 18h–1Fh) .....	200
Table 106: Ingress Mirror Divider Register (Page 03h: Address 20h–21h).....	200
Table 107: Ingress Mirror MAC Address Register (Page 03h: Address 22h–27h) .....	201

Table 108: Egress Mirror Control Register (Page 03h: Address 28h–2Fh) .....	202
Table 109: Egress Mirror Divider Register (Page 03h: Address 30h–31h).....	203
Table 110: Egress Mirror MAC Address Register (Page 03h: Address 32h–37h).....	203
Table 111: Special Management Control Register (Page 03h: Address 40h) .....	204
Table 112: MIB Snapshot Control Register (Page 03h: Address 50h).....	205
Table 113: Ingress RMON Register (Page 03h: Address 60h–67h).....	206
Table 114: Egress RMON Register (Page 03h: Address 68h–69h).....	207
Table 115: Chip Reset Control Register (Page 03h: Address 7Ch).....	207
Table 116: ARL Control Registers (Page 04h) .....	208
Table 117: Global ARL Configuration Register (Page 04h: Address 00h).....	208
Table 118: BPDU Multicast Address Register (Page 04h: Address 04h–09h).....	209
Table 119: Multiport Address 1 Register (Page 04h: Address 10h–15h).....	209
Table 120: Multiport Vector 1 Register (Page 04h: Address 18h–1Fh) .....	210
Table 121: Multiport Address 2 Register (Page 04h: Address 20h–25h).....	210
Table 122: Multiport Vector 2 Register (Page 04h: Address 28h–2Fh) .....	210
Table 123: ARL Access Registers (Page 05h).....	211
Table 124: ARL Read/Write Control Register (Page 05h: Address 00h) .....	213
Table 125: MAC Address Index Register (Page 05h: Address 02h–07h) .....	213
Table 126: VID Table Index Register (Page 05h: Address 08h–09h).....	214
Table 127: ARL Entry 0 Register, for Unicast Address Register (Page 05h: Address 10h–17h) .....	214
Table 128: ARL Entry, for Multicast Address Register (Page 05h: Address 10h–17h).....	215
Table 129: ARL Entry Register, for Unicast Address (Page 05h: Address 18h–1Fh) .....	217
Table 130: ARL Entry Register, for Multicast Address (Page 05h: Address 18h–1Fh) .....	218
Table 131: VID Entry Register (Page 05h: Address 20h–21h).....	218
Table 132: VID Entry Register (Page 05h: Address 28h–29h).....	219
Table 133: Multitable Index Register (Page 05h: Address 30h–31h) .....	219
Table 134: Multitable Data 0 Register (Page 05h: Address 38h–3Fh).....	221
Table 135: Multitable Data 1 Register (Page 05h: Address 40h–47h).....	224
Table 136: Multitable Data 2 Register (Page 05h: Address 48h–4Fh).....	225
Table 137: ARL Search Control Register (Page 05h: Address 50h) .....	226
Table 138: ARL Search Address Register (Page 05h: Address 52h–53h) .....	226
Table 139: ARL Search Result Register (Page 05h: Address 54h–5Bh).....	227
Table 140: ARL Search Result VID Register (Page 05h: Address 5Ch–5Dh).....	228
Table 141: Priority Control Registers (Page 0Ah) .....	229
Table 142: Flow Control Diagnostic Register (Page 0Ah: Address 00h–01h) .....	232
Table 143: Queue 0 100 Tx Threshold Control 1 Register (Page 0Ah: Address 06h–07h).....	232



Table 144: Queue 0 100 Tx Threshold Control 2 Register (Page 0Ah: Address 08-09h) .....	233
Table 145: Global Threshold Control 1 Register (Page 0Ah: Address 0E-0Fh) .....	233
Table 146: Global Threshold Control 2 Register (Page 0Ah: Address 10-11h) .....	234
Table 147: Transmit Queue Threshold Control Register (Page 0Ah/Addr 12h-13h) .....	234
Table 148: Flow Control Status 2 Register (Page 0Ah/Addr 1Ch-1Dh) .....	235
Table 149: Flow Control Status 3 Register (Page 0Ah/Addr 1Eh-1Fh) .....	235
Table 150: Flow Control Status 4 Register (Page 0Ah/Addr 20h-21h) .....	235
Table 151: Flow Control Status 5 Register (Page 0Ah/Addr 22h-23h) .....	236
Table 152: Flow Control Status 7 Register (Page 0Ah/Addr 26h-27h) .....	236
Table 153: Flow Control Status 9 Register (Page 0Ah/Addr 2Ah-2Bh) .....	236
Table 154: Flow Control Status 10 Register (Page 0Ah/Addr 2Ch-2Dh) .....	237
Table 155: Flow Control Status 11 Register (Page 0Ah/Addr 2Eh-2Fh) .....	237
Table 156: Global Option Control Register (Page 0Ah: Address 30h-31h) .....	237
Table 157: CPU/MII Threshold Control Register (Page 0Ah/Addr 32h-33h) .....	238
Table 158: Pre-Queue TX Drop Control Register (Page 0Ah/Addr 34h-35h) .....	239
Table 159: MON Flow Control Reg Bus Register (Page 0Ah/Addr 36h-37h) .....	239
Table 160: Flow Control Status 12 Register (Page 0Ah/Addr 3Ch-3Dh) .....	239
Table 161: Misc TX Flow Control Register (Page 0Ah/Addr 4Ah-4Bh) .....	239
Table 162: Queue Congestion Status 0 Register (Page 0Ah/Addr 50h-51h) .....	240
Table 163: Queue Congestion Status 1 Register (Page 0Ah/Addr 52h-53h) .....	240
Table 164: Queue Congestion Status 2 Register (Page 0Ah/Addr 54h-55h) .....	240
Table 165: Queue Congestion Status 3 Register (Page 0Ah/Addr 58h-59h) .....	240
Table 166: Queue Congestion Status 4 Register (Page 0Ah/Addr 5Ah-5Bh) .....	241
Table 167: Queue Congestion Status 5 Register (Page 0Ah/Addr 5Ch-5Dh) .....	241
Table 168: Queue 0 TxDsc Control Register (Page 0Ah: Address 64h-65h) .....	241
Table 169: Queue 1 100BT Threshold Control 1 Register (Page 0Ah: Address 6Ah-6Bh) .....	242
Table 170: Queue 1 100BT Threshold Control 2 Register (Page 0Ah: Address 6Ch-6Dh) .....	242
Table 171: Queue 1 TxDsc Control Register (Page 0Ah: Address 72h-73h) .....	243
Table 172: Queue 2 100TX Threshold Control 1 Register (Page 0Ah: Address 78h-79h) .....	243
Table 173: Queue 2 100TX Threshold Control 2 Register (Page 0Ah: Address 7Ah-7Bh) .....	244
Table 174: Queue 2 TxDsc Control Register (Page 0Ah: Address 80h-81h) .....	244
Table 175: Queue 3 100TX Threshold Control 1 Register (Page 0Ah: Address 86h-87h) .....	245
Table 176: Queue 3 100TX Threshold Control 2 Register (Page 0Ah: Address 88h-89h) .....	245
Table 177: RX Base Buffer Number Register (Page 0Ah/Addr 8Ah-8Bh) .....	246
Table 178: Queue 3 TxDsc Control Register (Page 0Ah: Address 8Eh-8Fh) .....	246
Table 179: Reserved Buffer Number Register (Page 0Ah/Addr 90h-91h) .....	246

Table 180: Received Base Flow Control Register (Page 0Ah/Addr 92h-93h) .....	247
Table 181: DLF Threshold Drop Register (Page 0Ah: Address 94h-95h).....	247
Table 182: Broadcast Threshold Drop Register (Page 0Ah: Address 96h-97h).....	248
Table 183: LAN to IMP MC Control 1 Register (Page 0Ah: Address A0h-A1h).....	248
Table 184: LAN to IMP MC Control 1 Register (Page 0Ah: Address A2h-A3h).....	249
Table 185: LAN to IMP MC Control 2 Register (Page 0Ah: Address A4h-A5h).....	249
Table 186: IMP to LAN Control 1 Register (Page 0Ah: Address B0h-B1h) .....	249
Table 187: LAN to IMP MC Control 2 Register (Page 0Ah: Address B2h-B3h).....	249
Table 188: Queue 1 Total Threshold Control 1 Register (Page 0Ah: Address C0h-C1h).....	250
Table 189: Queue 1 Total Threshold Control 2 Register (Page 0Ah: Address C2h-C3h).....	250
Table 190: Queue 2 Total Threshold Control 1 Register (Page 0Ah: Address C4h-C5h).....	250
Table 191: Queue 2 Total Threshold Control 2 Register (Page 0Ah: Address C6h-C7h).....	250
Table 192: Queue 3 Total Threshold Control 1 Register (Page 0Ah: Address C8h-C9h).....	250
Table 193: Queue 3 Total Threshold Control 2 Register (Page 0Ah: Address CAh-CBh) .....	251
Table 194: Queue 1 Total BC/DLF Drop Threshold Control Register (Page 0Ah/Addr D0h-D1h).....	251
Table 195: Queue 2 Total BC/DLF Drop Threshold Control Register (Page 0Ah/Addr D2h-D3h).....	251
Table 196: Queue 3 Total BC/DLF Drop Threshold Control Register (Page 0Ah/Addr D4h-D5h).....	251
Table 197: TBI Registers (Page 0Dh).....	253
Table 198: TBI Control Register (Page 0Dh: Address 00h-01h) .....	253
Table 199: PRBS Control Register (Page 0Dh: Address 02h) .....	254
Table 200: PRBS Status Register (Page 0Dh: Address 03h-06h) .....	255
Table 201: MR Status Register (Page 0Dh: Address 07h).....	256
Table 202: SGMII Clear Control Register (Page 0Dh: Address 08h).....	256
Table 203: Gigabit Port SGMII Control Register (Page 0Dh: Address 50h-53h).....	257
Table 204: Gigabit Port SGMII Status Register (Page 0Dh: Address 54h-57h).....	258
Table 205: Gigabit Port Link Partner Link Status Register (Page 0Dh: Address 58h-5Bh) .....	258
Table 206: Gigabit Port CRC16 Register (Page 0Dh: Address 5Ch-5Fh).....	258
Table 207: PHY Info Registers (Page 10h).....	259
Table 208: PHY ID High Register (Page 10h: Address 04h).....	259
Table 209: PHY ID Low Register (Page 10h: Address 06h).....	259
Table 210: Chip Revision .....	259
Table 211: CFP Registers (Page 20h) .....	260
Table 212: CFP Access Register (Page 20h: Address 00h-03h) .....	262
Table 213: CFP TCAM Data 0 Register (Page 20h: Address 10h-17h).....	262
Table 214: CFP TCAM Data 1 Register (Page 20h: Address 18h-1Fh).....	263
Table 215: CFP TCAM Data 2 Register (Page 20h: Address 20h-27h).....	263

Table 216: CFP TCAM Data 3 Register (Page 20h: Address 28h–2Fh) .....	263
Table 217: CFP TCAM Data 4 Register (Page 20h: Address 30h–37h) .....	263
Table 218: CFP TCAM Data 5 Register (Page 20h: Address 38h–3Fh) .....	264
Table 219: CFP TCAM Mask 0 Register (Page 20h: Address 40h–47h) .....	264
Table 220: CFP TCAM Mask 1 Register (Page 20h: Address 48h–4Fh) .....	264
Table 221: CFP TCAM Mask 2 Register (Page 20h: Address 50h–57h) .....	264
Table 222: CFP TCAM Mask 3 Register (Page 20h: Address 58h–5Fh) .....	265
Table 223: CFP TCAM Mask 4 Register (Page 20h: Address 60h–67h) .....	265
Table 224: CFP TCAM Mask 5 Register (Page 20h: Address 68h–6Fh) .....	265
Table 225: CFP Action Policy Data Register (Page 20h: Address 70h–75h) .....	265
Table 226: CFP Rate Meter Configuration Register (Page 20h: Address 80h–83h) .....	270
Table 227: CFP Rate Inband Statistic Register (Page 20h: Address 90h–93h) .....	270
Table 228: CFP Rate Outband Statistic Register (Page 20h: Address 94h–97h) .....	270
Table 229: CFP Control Registers (Page 21h) .....	271
Table 230: CFP Global Control Register (Page 21h: Address 00h) .....	272
Table 231: Range Checker Control Register (Page 21h/Addr 08h) .....	272
Table 232: CFP Global Control 1 Register (Page 21h: Address 10h–11h) .....	274
Table 233: CFP Enable Control Register (Page 21h: Address 20h–27h) .....	274
Table 234: VID Range Checker 0 Register (Page 21h: Address 30h–33h) .....	274
Table 235: VID Range Checker 1 Register (Page 21h: Address 34h–37h) .....	274
Table 236: VID Range Checker 2 Register (Page 21h: Address 38h–3Bh) .....	275
Table 237: VID Range Checker 3 Register (Page 21h: Address 3Ch–3Fh) .....	275
Table 238: L4 Port Range Checker 0 Register (Page 21h: Address 40h–43h) .....	275
Table 239: L4 Port Range Checker 1 Register (Page 21h: Address 44h–47h) .....	275
Table 240: L4 Port Range Checker 2 Register (Page 21h: Address 48h–4Bh) .....	275
Table 241: L4 Port Range Checker 3 Register (Page 21h: Address 4Ch–4Fh) .....	276
Table 242: Other Checker Register (Page 21h: Address 50h–51h) .....	276
Table 243: CFP UDF Control Registers (Page 22h) .....	276
Table 244: CFP UDF A0 Control Register (Page 22h: Address 00h) .....	278
Table 245: CFP UDF A1 Control Register (Page 22h: Address 01h) .....	278
Table 246: CFP UDF A2 Control Register (Page 22h: Address 02h) .....	278
Table 247: CFP UDF B0 Control Register (Page 22h: Address 10h) .....	279
Table 248: CFP UDF B1 Control Register (Page 22h: Address 11h) .....	279
Table 249: CFP UDF B2 Control Register (Page 22h: Address 12h) .....	279
Table 250: CFP UDF B3 Control Register (Page 22h: Address 13h) .....	280
Table 251: CFP UDF B4 Control Register (Page 22h: Address 14h) .....	280

Table 252: CFP UDF B5 Control Register (Page 22h: Address 15h) .....	281
Table 253: CFP UDF B6 Control Register (Page 22h: Address 16h) .....	281
Table 254: CFP UDF B7 Control Register (Page 22h: Address 17h) .....	281
Table 255: CFP UDF B8 Control Register (Page 22h: Address 18h) .....	282
Table 256: CFP UDF B9 Control Register (Page 22h: Address 19h) .....	282
Table 257: CFP UDF B10 Control Register (Page 22h: Address 1Ah) .....	283
Table 258: CFP UDF C0 Control Register (Page 22h: Address 20h) .....	283
Table 259: CFP UDF C1 Control Register (Page 22h: Address 21h) .....	283
Table 260: CFP UDF C2 Control Register (Page 22h: Address 22h) .....	284
Table 261: CFP UDF D0 Control Register (Page 22h: Address 30h) .....	284
Table 262: CFP UDF D1 Control Register (Page 22h: Address 31h) .....	285
Table 263: CFP UDF D2 Control Register (Page 22h: Address 32h) .....	285
Table 264: CFP UDF D3 Control Register (Page 22h: Address 33h) .....	285
Table 265: CFP UDF D4 Control Register (Page 22h: Address 34h) .....	286
Table 266: CFP UDF D5 Control Register (Page 22h: Address 35h) .....	286
Table 267: CFP UDF D6 Control Register (Page 22h: Address 36h) .....	287
Table 268: CFP UDF D7 Control Register (Page 22h: Address 37h) .....	287
Table 269: QoS Registers (Page 30h) .....	288
Table 270: QoS Control Register (Pages: 30h, Address 10h–17h) .....	289
Table 271: QoS 802.1p Enable Register (Page 30h: Address 18h–1Fh) .....	290
Table 272: QoS DiffServ Enable Register (Page 30h: Address 20h–27h) .....	291
Table 273: QoS Pause Enable Register (Page 30h: Address 28h–2Fh) .....	292
Table 274: Priority Threshold Register (Page 30h: Address 30h–31h) .....	292
Table 275: DiffServ DSCP Priority Register 1 (Page 30h: Address 40h–47h) .....	293
Table 276: DiffServ DSCP Priority Register 2 (Page 30h: Address 48h–4Fh) .....	293
Table 277: QoS Reason Code Enable Register (Page 30h: Address 58h–59h) .....	293
Table 278: MAC-Based Aggregation Registers (Page 31h) .....	295
Table 279: Global Aggregation Control Register (Page 31h, Address 00h) .....	296
Table 280: Aggregation Control Group n Register .....	297
Table 281: Port Egress Control Registers (Page 33h) .....	298
Table 282: Port Egress Control Register (Pages: 33h, Address 00h–D7h) .....	299
Table 283: 802.1Q VLAN Registers (Page 34h) .....	300
Table 284: 802.1Q Control 0 Register (Pages: 34h, Address 00h) .....	301
Table 285: 802.1Q Control 1 Register (Pages: 34h, Address 01h) .....	301
Table 286: 802.1Q Control 2 Register (Pages: 34h, Address 02h) .....	304
Table 287: 802.1Q Control 3 Register (Pages: 34h, Address 08h–0Fh) .....	305

Table 288: 802.1Q Control 4 Register (Pages: 34h, Address 03h).....	306
Table 289: 802.1Q Control 5 Register (Pages: 34h, Address 04h).....	307
Table 290: 802.1Q Default Port Tag Register (Page: 34h, Address 40h–75h).....	308
Table 291: Default 802.1Q Tag.....	309
Table 292: Global Double Tagging Control Register (Pages: 34h, Address 90h).....	309
Table 293: SP Portmap Selection Register (Pages: 34h, Address 98h–9Fh).....	311
Table 294: VLAN To VLAN Control Register (Pages: 34h, Address A0h–A7h).....	312
Table 295: MAC To VLAN Control Register (Pages: 34h, Address A8h–AFh).....	313
Table 296: Protocol To VLAN Control Register (Pages: 34h, Address B0h–B7h).....	314
Table 297: Trusted Customer VLAN Register (Page 34h: Address B8h–BFh).....	315
Table 298: 802.1x Registers (Page 40h).....	316
Table 299: Port EAP Configuration Register (Page: 40h, Address 00h–1Ah).....	317
Table 300: EAP Configuration Register.....	318
Table 301: Port EAP Destination Address Register (Page: 40h, Address 20h–BCh).....	320
Table 302: EAP Unicast Destination Address.....	320
Table 303: 802.1x_1 Registers.....	322
Table 304: EAP Destination IP Register 0 (Page 41h, Address 00h–07h).....	322
Table 305: EAP Destination IP Register 1 (Page 41h, Address 08h–0Fh).....	322
Table 306: EAP Global Configuration Register (Page 41h, Address 10h–11h).....	322
Table 307: Learning counter Control Register (Page 40h, Address 18h–19h).....	323
Table 308: Port Max Learn Register (Page 41h/Addr 20h–5Fh).....	325
Table 309: Max Learn Number of Address Register.....	325
Table 310: Port SA Count Register (Page: 41h, Address 60h–98h).....	326
Table 311: Port SA Count register.....	327
Table 312: Rate Control Registers (Page 43h).....	328
Table 313: Rate Control Memory Access Register (Page: 43h, Address 00h).....	328
Table 314: Rate Control Memory Port Register (Page: 43h, Address 01h).....	329
Table 315: Rate Control Memory Data Register 0 (Page: 43h, Address 10h).....	330
Table 316: Rate Control Memory Data Register 1 (Page: 43h, Address 14h).....	331
Table 317: Rate Control Memory Data Register 2 (Page: 43h, Address 18h).....	332
Table 318: Rate Control Memory Data Register 3 (Page: 43h, Address 1Ch).....	333
Table 319: Rate Control Memory Data Register 4 (Page: 43h, Address 20h).....	333
Table 320: 802.1s Multiple Spanning Tree Registers (Page 45h).....	334
Table 321: MST Control Register (Page 45h, Address 00h).....	334
Table 322: Age-Out Control Register (Page 45h, Address 04h–07h).....	335
Table 323: Port MIB Registers (Page 68h–84h).....	336

Table 324: Snapshot Port MIB Registers (Page 85h) .....	338
Table 325: FE Port MII Registers Page Versus PHY .....	340
Table 326: Port MII Registers (Page A0h–B7h).....	340
Table 327: MII Control Register (Pages A0h–B7h, Address 00h–01h).....	342
Table 328: MII Status Register (Pages A0h–B7h, Address 02h–03h).....	344
Table 329: PHY Identifier Registers (Pages A0h–B7h, Addresses 04h–05h and 06h–07h) .....	347
Table 330: Auto-Negotiation Advertisement Register (Pages A0h–B7h, Address 08h–09h).....	347
Table 331: Auto-Negotiation Link Partner Ability Register (Pages A0h–B7h, Address 0Ah–0Bh).....	348
Table 332: Auto-Negotiation Expansion Register (Pages A0h–B7h, Address 0Ch–0Dh) .....	349
Table 333: Next Page Transmit Register (Pages A0h–B7h, Address 0Eh–0Fh).....	351
Table 334: Link Partner Next Page Register (Pages A0h–B7h, Address 10h–11h) .....	352
Table 335: External Port MII Registers Page Versus PHY .....	353
Table 336: External PHY Registers (Page D8h–DAh) .....	353
Table 337: Global Registers (Maps to All Pages) .....	355
Table 338: SPI Data I/O Register (Maps to All Registers, Address F0h–F7h).....	355
Table 339: SPI Status Register (Maps to All Registers, Address FEh) .....	355
Table 340: Page Register (Maps to All Registers, Address FFh) .....	356
Table 341: Absolute Maximum Ratings.....	357
Table 342: Recommended Operating Conditions .....	357
Table 343: Electrical Characteristics.....	358
Table 344: Reset and Clock Timing.....	360
Table 345: Serial LED Timing .....	361
Table 346: MII Input Timing .....	362
Table 347: RvMII Input Timing .....	363
Table 348: MII Output Timing .....	364
Table 349: RvMII Output Timing .....	365
Table 350: RGMII Output Timing (Normal Mode).....	366
Table 351: RGMII Output Timing (Delayed Mode Clock) .....	367
Table 352: RGMII Input Timing (Normal Mode).....	368
Table 353: RGMII Input Timing (Delayed Mode Clock) .....	369
Table 354: GMII Output Timing.....	370
Table 355: GMII Input Timing.....	371
Table 356: TBI Output Timing.....	372
Table 357: TBI Input Timing.....	372
Table 358: SPI Timing .....	374
Table 359: EEPROM Timing .....	376

Table 360: Management Data Interface (Slave Mode) .....	377
Table 361: Management Data Interface (Master Mode) .....	377
Table 362: 400-PBGA Thermal Characteristics with External Heat Sink at 70°C .....	378
Table 363: 400-PBGA Thermal Characteristics with External Heat Sink at 85°C .....	378
Table 364: Ordering Information .....	381

Broadcom Confidential

## About This Document

### Purpose and Audience

This document provides details of the functional, operational, and electrical characteristics of the Broadcom<sup>®</sup> BCM53242M. It is intended for hardware design, application, and OEM engineers.

### Acronyms and Abbreviations

In most cases, acronyms and abbreviations are defined on first use.

For a comprehensive list of acronyms and other terms used in Broadcom documents, go to:  
<http://www.broadcom.com/press/glossary.php>.

### Document Conventions

The following conventions may be used in this document:

<i>Convention</i>	<i>Description</i>
<b>Bold</b>	User input and actions: for example, type <b>exit</b> , click <b>OK</b> , press <b>Alt+C</b>
Monospace	Code: <code>#include &lt;iostream&gt;</code> HTML: <code>&lt;td rowspan = 3&gt;</code> Command line commands and parameters: <code>wl [-1] &lt;command&gt;</code>
< >	Placeholders for <i>required</i> elements: enter your <username> or <code>wl &lt;command&gt;</code>
[ ]	Indicates <i>optional</i> command-line parameters: <code>wl [-1]</code> Indicates bit and byte ranges (inclusive): <code>[0:3]</code> or <code>[7:0]</code>

## Technical Support

Broadcom provides customer access to a wide range of information, including technical documentation, schematic diagrams, product bill of materials, PCB layout information, and software updates through its customer support portal (<https://support.broadcom.com>). For a CSP account, contact your Sales or Engineering support representative.

In addition, Broadcom provides other product support through its Downloads & Support site (<http://www.broadcom.com/support/>).



Broadcom Confidential

# Section 1: Introduction

---

## Overview

The Broadcom® BCM53242M is a single-chip, 24-port 10/100Base-TX and 2-port 10/100/1000Base-T GMII switch device. This device integrates the following functions:

- 24 fully integrated 10/100Base-TX/EFX compatible PHY transceivers
- Two-port 10/100/1000 GMII/RGMII/TBI interface
- 25 integrated 10/100 MACs
- Management port via RvMII/MII interface
- A Serial Peripheral Interface (SPI) and MDC/MDIO Interface allowing the device to be custom-configured
- Flexible TCAM-based Compact Field Processor
- High-performance integrated packet buffer memory
- An address resolution engine
- Nonblocking switch controller
- Set of Management Information Base (MIB) statistics registers

The Serial Peripheral Interface allows the device to be custom-configured and bridge management to be implemented.

The integrated 10/100Base-TX transceivers perform all the physical layer interface functions for 100Base-TX full-duplex or half-duplex Ethernet on CAT-5 twisted pair cable and 10Base-T full-duplex or half-duplex Ethernet on CAT-3, -4, or -5 cable. Each of the integrated transceiver ports of the BCM53242M connects directly to the network media through isolation transformers. The integrated transceiver is fully compliant with the IEEE 802.3 and 802.3u standards.

Each MAC supports full and half-duplex for 10 Mbps and 100 Mbps and the Gigabit MACs additional support full-duplex operation at 1 Gbps. Flow control is provided in half-duplex mode with backpressure. In full-duplex mode, 802.3x frame-based flow control is provided. The MAC is 802.3 compliant and supports a maximum frame size of 2048 bytes.

The BCM53242M supports advanced ContentAware™ processing via a Compact Fast Field Processor (CFP). Up to three intelligent ContentAware processes are performed in parallel for every packet. This flexible engine uses a TCAM-based architecture with wildcard capabilities; specific areas of the incoming packet to be masked and matched can be defined. Furthermore, multiple actions can be performed per packet as a result of a match. Action examples include dropping, changing of the port forwarding map, changing priority of frame, etc. These advanced ContentAware processes are well suited for both Access Control List and Security protection, for example, DOS prevention.

An integrated address management engine provides address learning and recognition functions at maximum frame rates. The address table provides capacity for up to 8K unicast and multicast addresses. Addresses are added to the table after receiving an error-free packet. Broadcast and multicast frames are forwarded to all ports within the VLAN domain except the port where it was received.

The MIB statistics registers collect receive and transmit statistics for each port, and provide direct hardware support for the Etherlike MIB, Bridge MIB, MIB II (Interfaces), and the first four groups of the RMON MIB. All nine groups of RMON can be supported by using additional capabilities, such as port mirroring/snooping, together with an external microcontroller to process some MIB attributes. The MIB registers can be accessed through the Serial Peripheral Interface Port by an external microcontroller.

---

## Audience

This document is for designers interested in integrating the BCM53242M switch into their hardware designs, and others who need specific data about the physical characteristics and operation of the BCM53242M switch.

---

## Data Sheet Information

The following notational conventions are used in this document:

- Signal names are shown in UPPERCASE letters. For example: DATA
- A bar over a signal name indicates that it is active low. For example:  $\overline{CE}$ .
- In register and signal descriptions, [n:m] indicates a range from bit n to bit m. For example: [7:0] indicates bits 7 through 0, inclusive.
- The use of R or RESERVED indicates that a bit or field is reserved by Broadcom for future use. Typically R is used for individual bits and RESERVED is used for fields.
- Numerical modifiers such as K or M follow traditional usage. For example, 1 KB means 1,024 bytes, 100 Mbps (referring to Fast Ethernet speed) means 100,000,000 bits per second, and 133 MHz means 133,000,000 Hertz.

Where it seems helpful, cross-reference links have been incorporated in the data sheet. The cross-reference is denoted in blue text. When using a PDF version of the data sheet, jump to other sections of the data sheet by clicking on the blue text using the PDF hand tool.

**Example:** Clicking on the text: [“Features and Operation” on page 36](#) jumps to the next section. To return, press the left-arrow key while holding down the alt key. It returns to the previous view. Likewise, pressing the right-arrow key while holding down the alt key jumps to next view.

As always, every effort is made to improve the data sheet and other documentation. To submit suggestions, send e-mail to [RoboDocs@broadcom.com](mailto:RoboDocs@broadcom.com). For technical questions, please contact your local sales representative.

## Section 2: Features and Operation

---

### Overview

The BCM53242M includes the following features:

- “Quality of Service” on page 37
- “Port-Based VLANs” on page 42
- “802.1Q VLANs” on page 43
- “MAC-based VLANs” on page 43
- “Protocol-based VLANs” on page 43
- “Customer-Tag-Based VLANs” on page 43
- “Double Tagging” on page 45
- “Link Aggregation” on page 51
- “Rate Control” on page 52
- “Protected Ports” on page 54
- “Port Mirroring” on page 55
- “IGMP and MLD Snooping” on page 56
- “Jumbo Frame Support” on page 56
- “802.1x Port-Based Security” on page 56
- “Dynamic Secure MAC Mode” on page 57
- “Address Management” on page 57
- “Bridge Management” on page 63
- “Compact Field Processor” on page 65
- “Packet Remarking” on page 73
- “VID Replacement” on page 74

Each topic is discussed in more detail in the following sections.

---

## Quality of Service

The Quality of Service (QoS) feature provides up to four internal queues per port to support four different traffic priorities. These priorities can be programmed in such a way that higher-priority traffic experiences less delay in the switch under congested conditions than the latency of lower-priority traffic. This can be important in minimizing latency for delay-sensitive traffic. The BCM53242M can assign the packet to one of the four egress transmit queues according to information in:

- [“Port-Based QoS” on page 38](#) (ingress port ID)
- [“802.1p QoS” on page 38](#)
- [“Protocol-Based QoS” on page 39](#)
- [“MAC SA-Based QoS” on page 39](#)
- [“DiffServ Based QoS” on page 40](#)
- [“Reason Code Based QoS” on page 41](#)



**Note:** Only 1Q or 4Q mode is supported



**Note:** As a part of the QoS discussion, it is important to understand the BCM53242M Egress port Queue structure.

## Egress Transmit Queues

Each egress port can support up to four transmit queues. Each egress transmit queue contains a list specifying the packet transmission order. Every incoming frame is forwarded to one of the four egress transmit queues of the assigned egress port, based on its priority. The egress port transmits packets from each of the four transmit queues according to a configurable scheduling algorithm, which can be a combination of Strict Priority (SP) and/or Weighted Round Robin (WRR). The following scheduling algorithm combinations are available in the BCM53242M:

- Four Strict Priority queues
- Four Weighted Round Robin queues
- One Strict Priority and three Weighted Round Robin queues
- Two Strict Priority and two Weighted Round Robin queues

When a queue is designated as the strict-priority queue, all other lower-priority queues are prevented from transmitting packets until the strict-priority queue is empty. Furthermore, the traffic at each egress port is gated by a Shaper, so that the aggregated output from the queues can be scheduled by a programmable Egress Rate Control, with a granularity of 64 Kbps. Egress Rate Control details are further described within this data sheet.

[Figure 2](#) shows the Shaping-Scheduling structure of each Egress port.

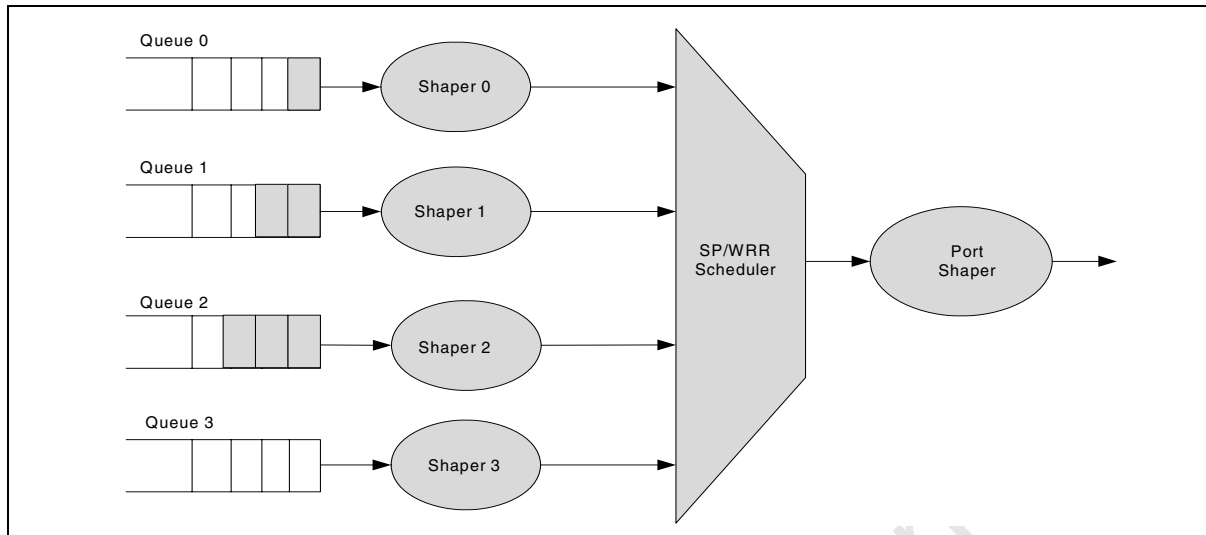

**Figure 2: Shaping-Scheduling Structure of Each Egress port**

## Port-Based QoS

When using the port-based priority mechanism, the port-based priority of each ingress port determines the egress queue assigned to frames arriving via the associated ingress port. The frames will be assigned to the priority queue based on the upper 3-bit per port COS value programmed in the 802.1Q Default Port Tag.

Follow the sequence below to enable Port-Based QoS:

- 1). Enable bit[63], as shown in [Table 270: “QoS Control Register \(Pages: 30h, Address 10h–17h\),”](#) on page 289.
- 2). Enable bits[59:58] of QoS Control register.
- 3). Program the upper 3-bit of per-port COS value as shown in [Table 290: “802.1Q Default Port Tag Register \(Page: 34h, Address 40h–75h\),”](#) on page 308.
- 4). To select the desired queue, program the register shown in [Table 274: “Priority Threshold Register \(Page 30h: Address 30h–31h\),”](#) on page 292.

## 802.1p QoS

When using 802.1p priority mechanism, the packet is examined for the presence of a valid 802.1p priority tag. If the tag is present, the packet is assigned to a programmable egress queue based on the value of the tagged priority. The tagged priority can be designated to any of the available queues.

Follow the sequence below to enable 802.1p QoS:

- 1). Enable bit[63], as shown in [Table 270: “QoS Control Register \(Pages: 30h, Address 10h–17h\),”](#) on page 289.
- 2). Enable bits[59:58] of QoS Control register.

3). To select the desired queue, program the register shown in [Table 274: “Priority Threshold Register \(Page 30h: Address 30h–31h\),” on page 292](#).

## Protocol-Based QoS

When using Protocol Based QoS, the EtherType field carried with the incoming packet is used to map the packet to one of the available output queues at the destination port. Protocol-based QoS shares the same control bit and 16-entry Protocol to VLAN mapping table with Protocol-based VLAN. The upper 3-bit in the Protocol to VLAN mapping table is used to program the Protocol-Based priority select field. This mapping can be enabled/disabled per port, but the mapping table is configured globally.

Follow the sequence below to enable Protocol-Based QoS:

1. Enable bit[63], of the QoS Control register (see [Table 270: “QoS Control Register \(Pages: 30h, Address 10h–17h\),” on page 289](#)).
2. Enable bits[59:58] of the QoS Control register.
3. Program the 3-bits of the per-port COS value in the Protocol to VLAN mapping table. (see TBL\_DATA\_0[30:28] of [Table 134: “Multitable Data 0 Register \(Page 05h: Address 38h–3Fh\),” on page 221](#)
4. To select the desired queue, program the Priority Threshold Register (see [Table 274: “Priority Threshold Register \(Page 30h: Address 30h–31h\),” on page 292](#)).
5. Program the Protocol to VLAN Control register (see [Table 296: “Protocol To VLAN Control Register \(Pages: 34h, Address B0h–B7h\),” on page 314](#)) to enable/disable per-port Protocol-Based QoS.

## MAC SA-Based QoS

When using MAC SA-Based QoS, the source address field carried with the incoming packet is used to map the packet to one of the available output queues at the destination port. MAC-Based QoS shares the same control bit and 512-entry MAC to VLAN mapping table with MAC-Based VLAN. The upper 3-bits in the MAC to VLAN mapping table is used to program the MAC-Based priority select field. This mapping can be enabled/disabled per port, but the mapping table is configured globally.

Follow the sequence below to enable MAC SA-Based QoS:

1. Enable bit[63], of the QoS Control register (see [Table 270: “QoS Control Register \(Pages: 30h, Address 10h–17h\),” on page 289](#)).
2. Enable bits[59:58] of the QoS Control register.
3. Program the 3-bits of the per-port COS value in the MAC to VLAN mapping table. (see TBL\_DATA\_0[62:60] of [Table 134: “Multitable Data 0 Register \(Page 05h: Address 38h–3Fh\),” on page 221](#)
4. To select the desired queue, program the Priority Threshold Register (see [Table 274: “Priority Threshold Register \(Page 30h: Address 30h–31h\),” on page 292](#)).
5. Program MAC to VLAN Control register. See [Table 295: “MAC To VLAN Control Register \(Pages: 34h, Address A8h–AFh\),” on page 313](#)) to enable/disable per port MAC-Based QoS.

## DiffServ Based QoS

When using the DiffServ priority mechanism, the packet is classified based on the DSCP field in the IP header. If the tag is present, the packet is assigned to a programmable egress queue based on the value of the tagged priority. The tagged priority can be designated to any of the available queues.

Follow the sequence below to enable DiffServ-Based QoS:

1. Enable bit[63], of the QoS Control register (see [Table 270: “QoS Control Register \(Pages: 30h, Address 10h–17h\),” on page 289](#)).
2. Enable bits[59:58] of the QoS Control register.
3. To select the desired queue, program the [Table 275: “DiffServ DSCP Priority Register 1 \(Page 30h: Address 40h–47h\),” on page 293](#) and [Table 276: “DiffServ DSCP Priority Register 2 \(Page 30h: Address 48h–4Fh\),” on page 293](#).

## QoS Resolution Tree

The resolution tree shown in the next figure determines which priority based QoS is used. There are two levels of determining which queue of egress port the packet is going to be assigned. The first level of how incoming packet QoS is determined is shown in [Figure 3](#), the QoS value from the first level QoS resolution is then muxed with the QoS value from the Compact Field Processor to be the final QoS value for the egress queue. The second level QoS resolution tree is shown in [Figure 4 on page 42](#).

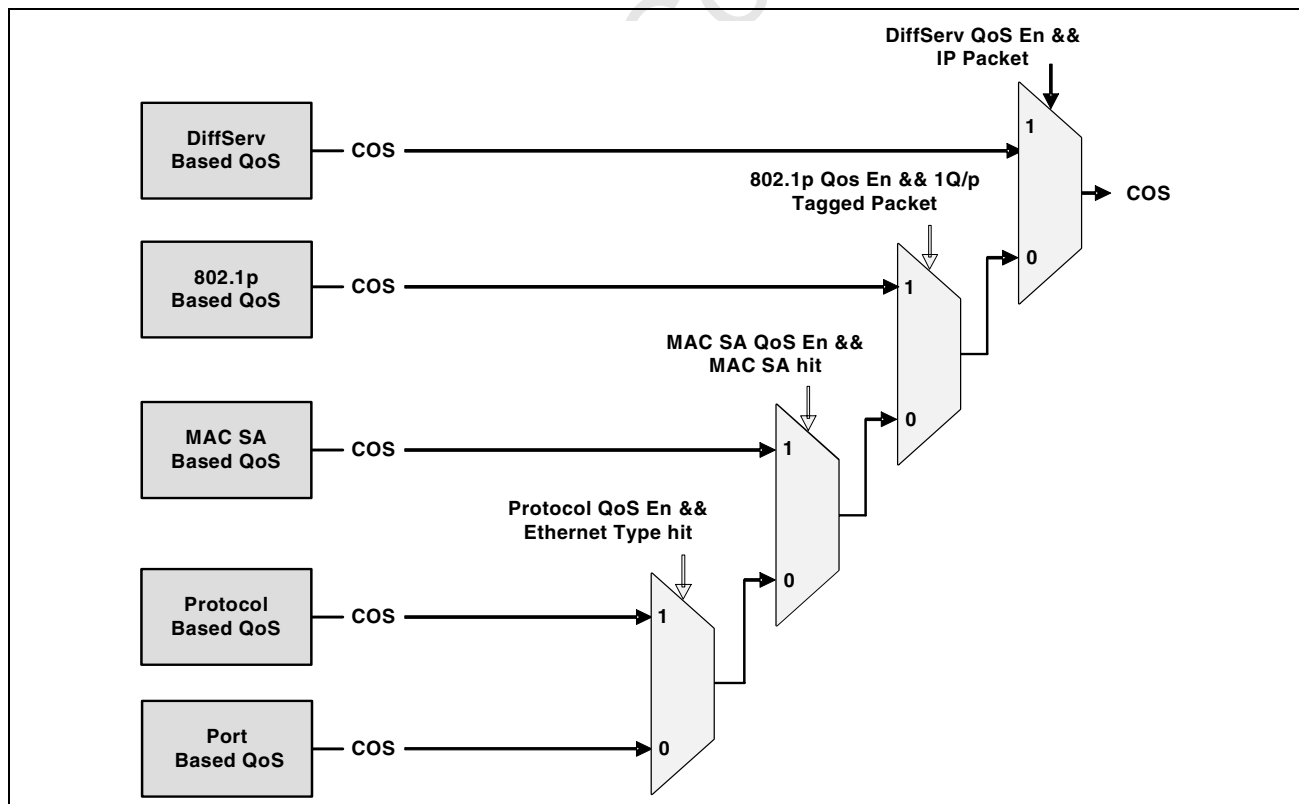

Figure 3: First Level QoS Resolution Tree



## Reason Code Based QoS

When the IMP port is configured as the management port, the BCM53242M provides a Reason Code Based QoS for packets being forwarded to the CPU through the IMP port. When the IMP port is configured as a regular data port, the packets are forwarded based on the QoS schemes mentioned above.

Table 1 lists the conditions where packets can be forwarded to the CPU, descriptions, and their default QoS levels. Note that the default QoS values are configurable (see Table 277: “QoS Reason Code Enable Register (Page 30h: Address 58h–59h),” on page 293). The QoS value for Mirroring and SA Learning conditions must be programmed with a lower, or equal value, compared to the other conditions. This prevents out-of-order flow delivery of identical packets to the CPU.

**Table 1: Reasons and QoS for CPU Traffic**

<b>Condition</b>	<b>Description</b>	<b>Default QoS level</b>
<b>Mirroring</b>	The packet is forwarded (copied) through the IMP port because it needs to be mirrored to the CPU as the capturing port.	0
<b>SA learning</b>	The packet is forwarded through the IMP port because the SA must be learned by the CPU.	0
<b>Switching</b>	The packet is forwarded through the IMP port, either because the CPU is one of the intended destination hosts of the packet, or because the switch logic determines to flood the packet to all potential destinations.	2
<b>Protocol Termination</b>	The packet is forwarded through the IMP port because it implies an IEEE 802.1 defined L2 protocol that needs to be terminated by the CPU.	3
<b>Protocol Snooping</b>	The packet is forwarded through the IMP port because it implies an L3 or application level protocol that needs to be monitored by the CPU for network security or operation efficiency.	2
<b>Exception Processing/ Flooding</b>	The packet is forwarded through the IMP port for some special processing even though the CPU is not the intended destination or because the switch makes the flooding decision to reach all potential destinations.	1

The Figure 4 shows the complete QoS Resolution tree structure.

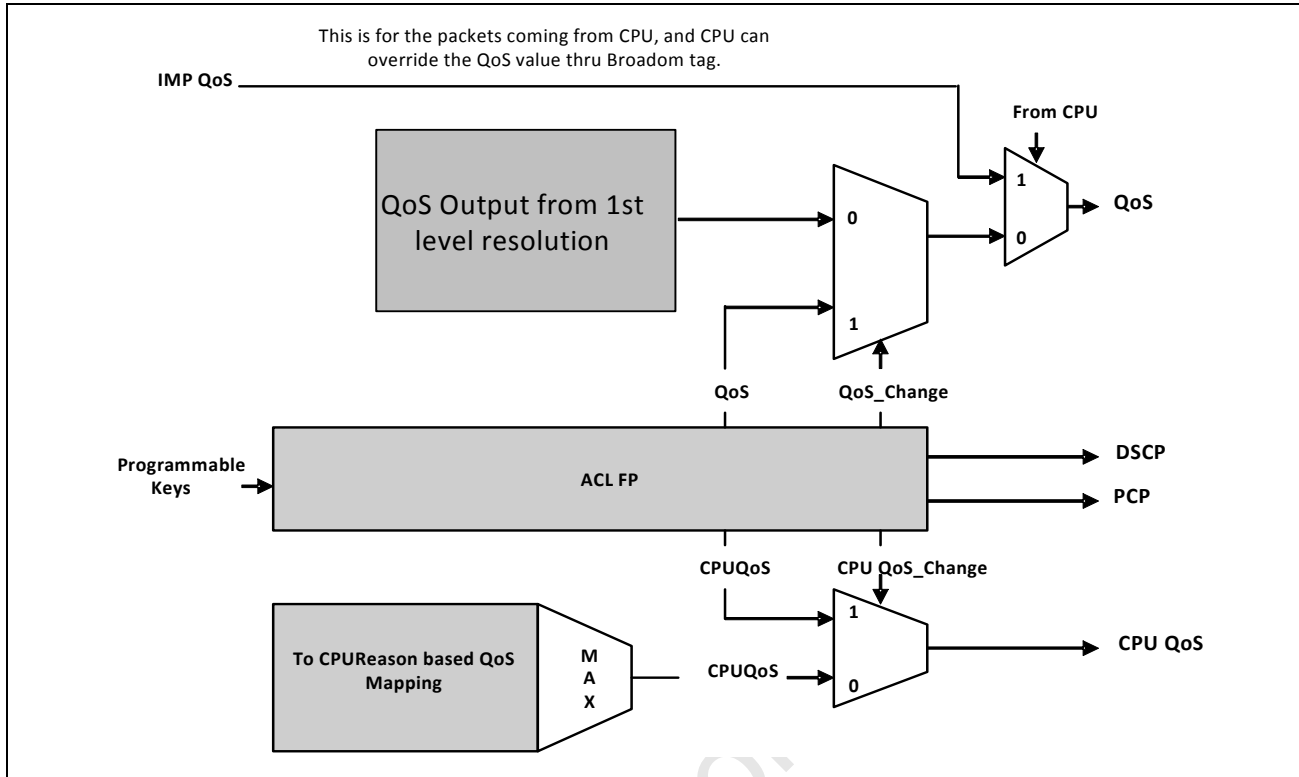

Figure 4: Final level QoS Resolution Tree

## Port-Based VLANs

The port-based virtual LAN (VLAN) feature partitions the switching ports into virtual private domains designated on a per port basis. Data switching outside of the port’s private domain is not allowed. The BCM53242M provides flexible VLAN configuration for each ingress (receiving) port.

The port-based VLAN feature works as a filter, filtering out traffic destined to nonprivate domain ports. The private domain ports are selected for each ingress port. Because the port selection is individual to each ingress port, it is possible for two ingress ports to not be granted bi-directional access. For each received packet, the ARL resolves the DA and obtains a forwarding vector (list of ports to which the frame shall be forwarded). The ARL then applies the VLAN filter to the forwarding vector, effectively masking out the nonprivate domain ports. The frame is only forwarded to those ports that meet the ARL table criteria, as well as the port-based VLAN criteria.

---

## 802.1Q VLANs

The BCM53242M supports IEEE 802.1Q VLAN and up to approximately 4K VLAN table entries that reside in the internal embedded memory. Once the VLAN table is programmed and maintained by the CPU, the BCM53242M will autonomously handle all protocol operations. These actions include the stripping or adding of the 802.1Q tag depending on the requirements of the individual transmitting port. It also performs all VLAN and MAC L2 lookups necessary to determine the correct packet routing.

---

## MAC-based VLANs

The BCM53242M supports MAC-based VLAN and up to 512 VLAN table entries that reside in the internal embedded memory. When the MAC-based VLAN is enabled, the VID is derived through the mapping table indexed by the MAC Source Address field embedded in the incoming packet. This mapping can be enabled/disabled per port, but the mapping table is configured globally. Once the VLAN mapping table is programmed and maintained by the CPU, the BCM53242M will autonomously handle all operations of the protocol.

---

## Protocol-based VLANs

The BCM53242M supports Protocol-based VLAN and up to 16 VLAN table entries that reside in the internal embedded memory. When Protocol-based VLAN is enabled, the VID is derived through the mapping table indexed by the EtherType field embedded in the incoming packet. This mapping can be enabled/disabled per port, but the mapping table is configured globally. Once the VLAN mapping table is programmed and maintained by the CPU, the BCM53242M will autonomously handle all operations of the protocol.

---

## Flow-based VLANs

The BCM53242M supports Flow-based VLAN. For more details, see [“VID Replacement” on page 74](#).

---

## Customer-Tag-Based VLANs

The BCM53242M supports customer-tag-based VLANs and up to 4K VLAN table entries that reside in the internal embedded memory. When customer-tag-based VLAN is enabled, the VID is derived through the mapping table indexed by the customer-tag VID embedded in the incoming packet. Each mapping entry may be configured for VLAN appending (Double Tagging) or VLAN replacement (VLAN Translation) operation. Once the VLAN mapping table is programmed and maintained by the CPU, the BCM53242M will autonomously handle all operations.

The [Figure 5](#) shows the VLAN resolution tree.

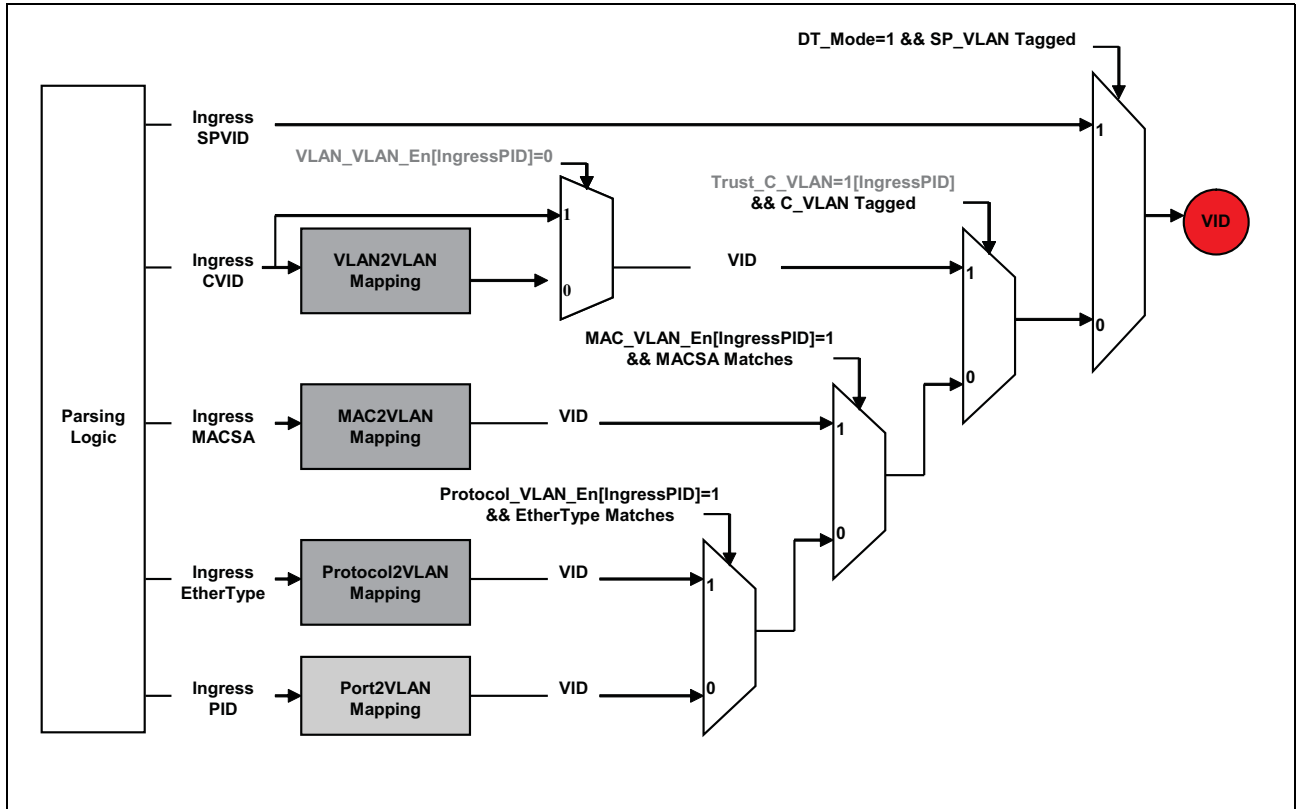

Figure 5: VLAN Resolution Tree

---

## Double Tagging

BCM53242M can be configured to operate either in Double Tagging mode for Edge Access Network Switching applications, or in Nondouble Tagging mode for traditional Local Area Network Switching applications. The Double Tagging mode is also referred as QinQ.

In **Double Tagging** mode,

- An Ethernet port can be configured either as a Network-Network Interface (NNI) port or as a User-Network Interface (UNI) port.
- There are four possible traffic profiles. Each possible traffic profile is described below, and illustrated in diagrams.
  - Incoming packets from NNI, and being forwarded to NNI (applies to Edge Access application)
  - Incoming packets from UNI, and being forwarded to NNI (applies to Edge Access application)
  - Incoming packets from NNI, and being forwarded to UNI
  - Incoming packets from UNI, and being forwarded to UNI

### NNI to NNI

The numbered process described below corresponds to the number in the diagram.

1. Over a NNI/NNI link, all incoming packets are expected to have a Service Provider (SP) Tag for normal switching traffic forwarding or untagged for peer CPU communication across the NNI link. (C-tagged (customer) or Priority-tagged packets are not supposed to be forwarded across a NNI link.
2. VLAN table is dedicated for Service Provider domain VLAN control. (The VID used to index the VLAN table is Service Provider Control for packet forwarding and learning operation, and the untag control can strip SP\_Tag only.)
3. With the Double Tagging (QinQ) process being performed, the VLAN translation operations are performed concurrently, either through the ingress VLAN remapping operations, or through the CFP action with the egress VLAN remapping operations.
4. Local CPU generated packets (incoming packets through IMP port with Broadcom tag) have options to preserve the untagged status or to be processed as normal input packets.

[Figure 6](#) shows how the extra (SP) tag is added to the incoming packets (tagged or untagged), and how the added tag can be output as is or be replaced.

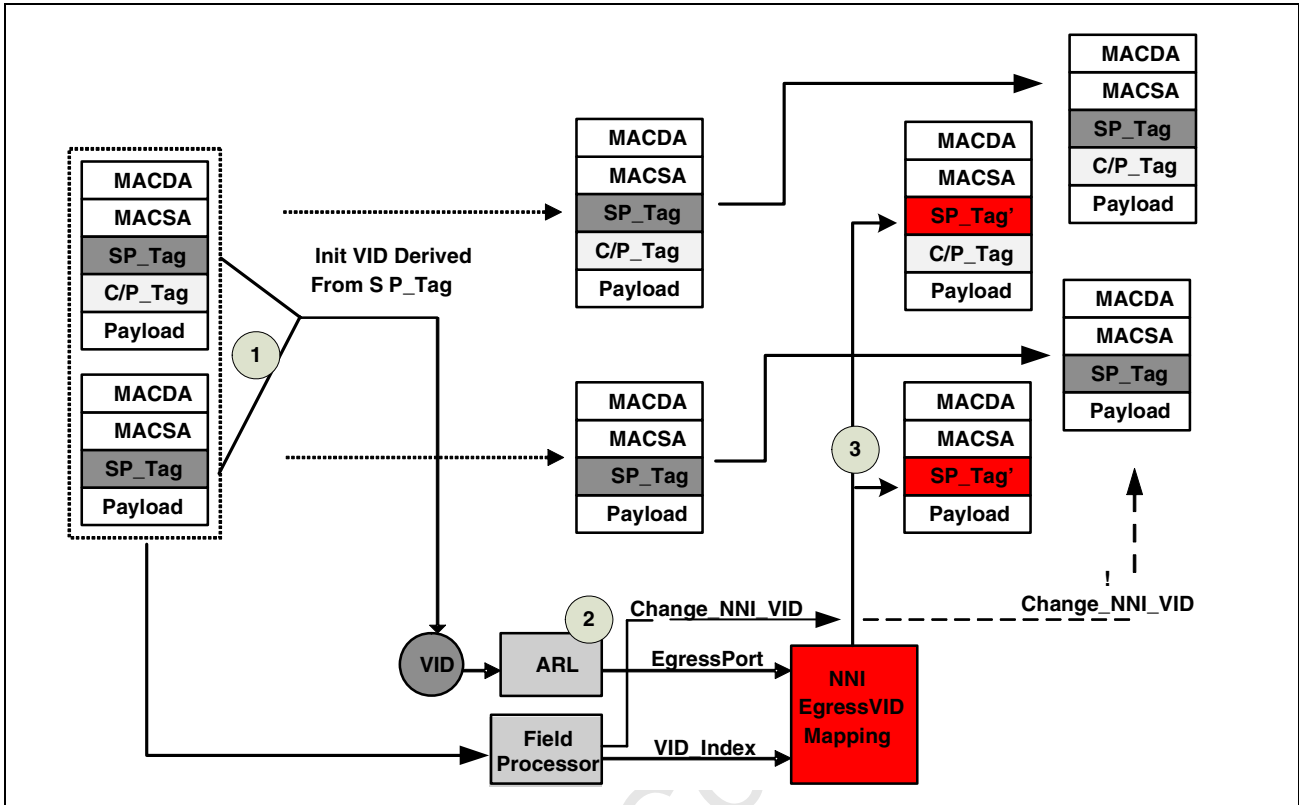

Figure 6: NNI to NNI Tag Handling

## UNI to NNI

The numbered process described below corresponds to the number in the diagram.

1. Over a UNI/NNI link, incoming packets can be Untagged, Priority tagged, or C tagged. (SP-tagged packets should not be forwarded across an UNI link.)
2. When an incoming packet from a UNI (customer) port is received, the packet is processed through the initial VID generation process (Port/ Protocol/ MACSA/ C\_VID-based mapping) to generate an SP tag and the SP tag is used to access the ARL table.
3. If the process is QinQ (double tagging or VLAN translation), the SP tag can be added as an outer tag, or the SP tag can be used to replace the original customer tag.
4. With the Double Tagging (QinQ) process being performed, the VLAN translation operations are performed through the CFP action with the egress VLAN remapping operations. If the matched rule indicates VID is present, the SP tag is replaced with the newly mapped SP tag at the NNI port for transmission.
5. Local CPU generated packets (incoming packets through IMP port with Broadcom tag) have options to preserve the untagged status or to be processed as normal input packets.

Figure 7 shows how the extra (SP) tag is added to the incoming packets (tagged or untagged), and how the added tag can be output as is or be replaced.

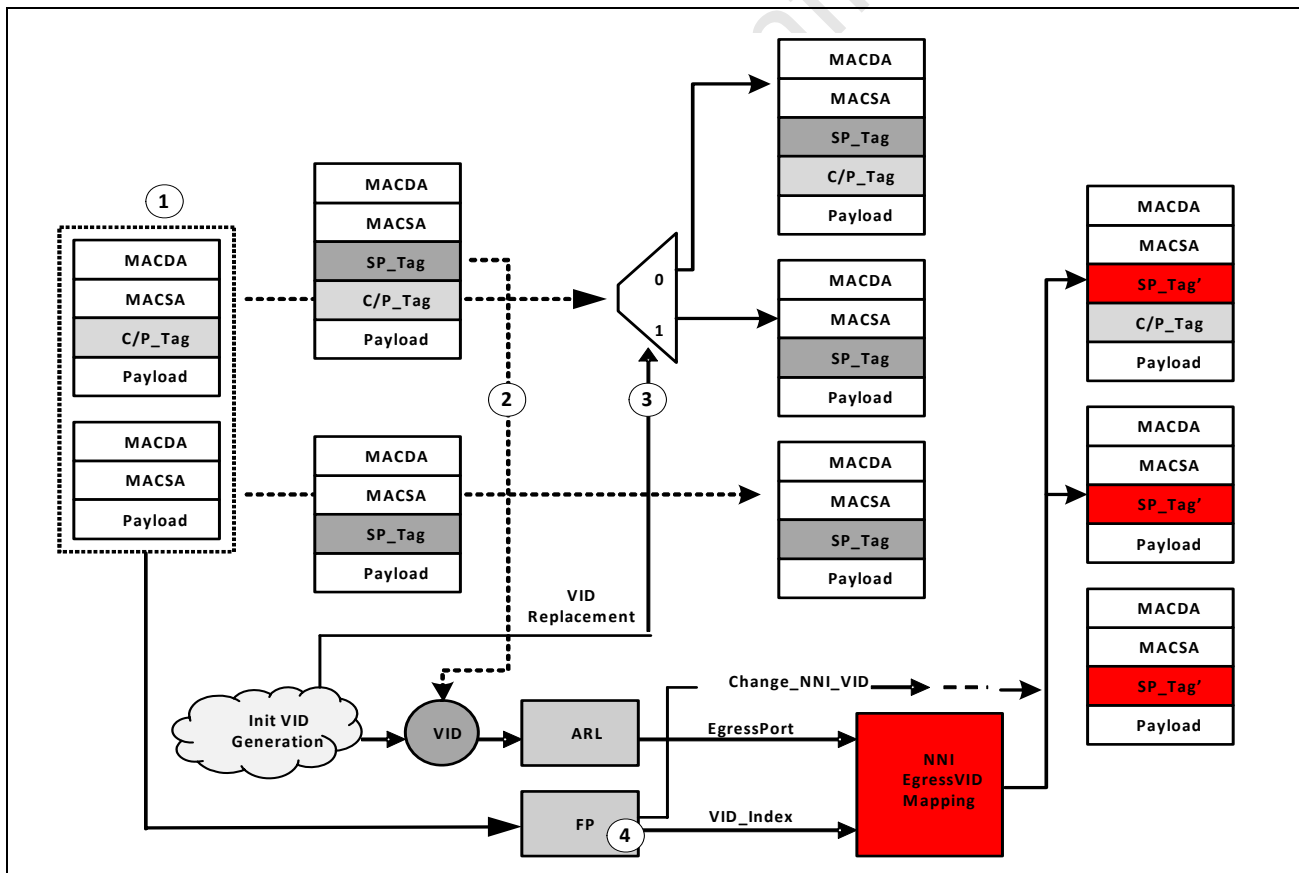

Figure 7: UNI to NNI

## NNI to UNI

The numbered process described below corresponds to the number in the diagram.

1. Over a NNI/UNI link, all incoming packets are expected to have a Service Provider (SP) Tag for normal switching traffic forwarding or untagged for peer CPU communication across the NNI link. (C-tagged (customer) or Priority-tagged packets are not supposed to be forwarded across a NNI link).
2. VLAN table is dedicated for Service Provider domain VLAN control. The VID used to index the VLAN table is Service Provider Control for packet forwarding and learning operation, and the untag control can strip SP\_Tag only.
3. With the Double Tagging (QinQ) process being performed, the VLAN translation operations are performed concurrently, either through the ingress VLAN remapping operations, or through the CFP action with the egress VLAN remapping operations.
4. Local CPU generated packets (incoming packets through the IMP port with a Broadcom tag) have options to preserve the untagged status or to be processed as normal input packets.

Figure 8 shows how the extra (SP) tag is added to the incoming packets (tagged or untagged), and how the added tag can be output as is or be replaced.

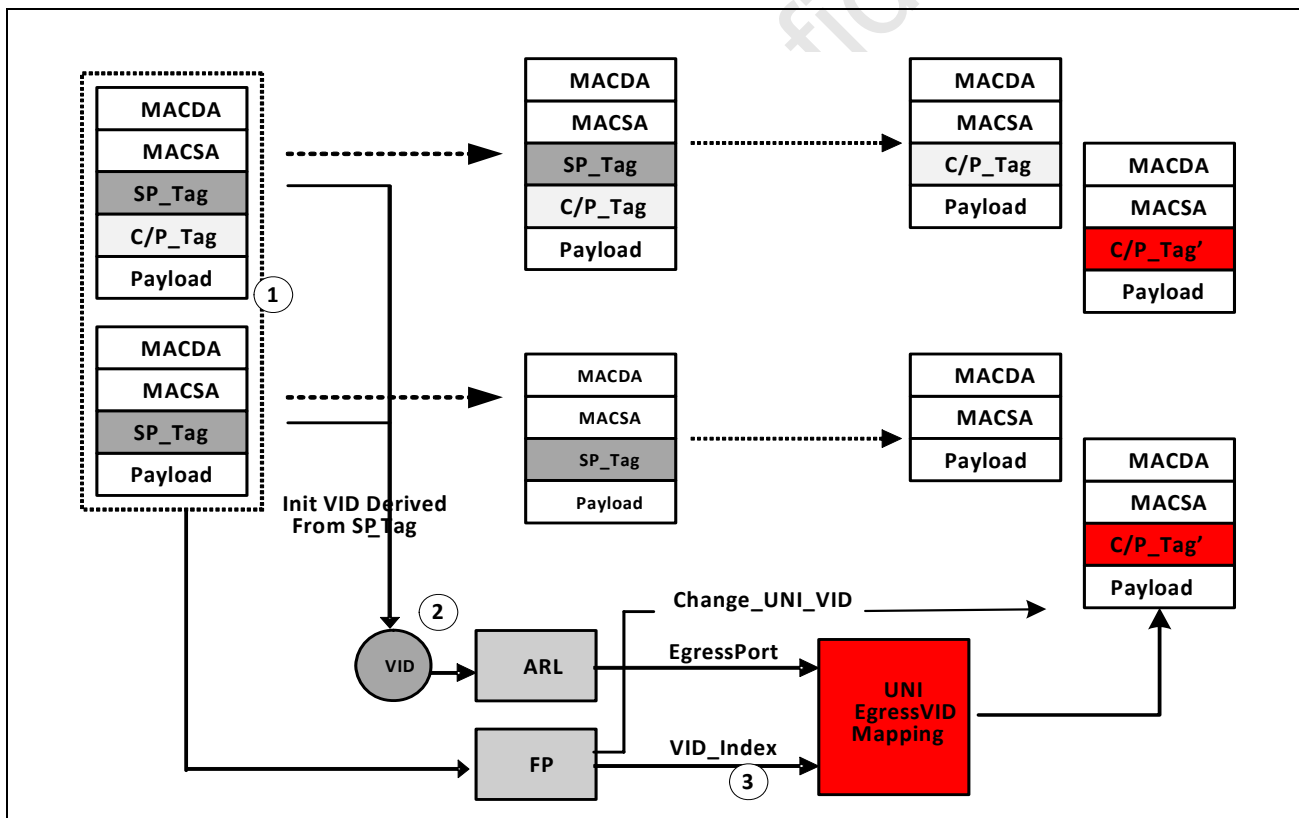

Figure 8: NNI to UNI

## UNI to UNI

The numbered process described below corresponds to the number in the diagram.



1. Over a UNI/UNI link, incoming packets can be Untagged, Priority tagged, or C tagged. (SP-tagged packets are not supposed to be forwarded across a UNI link.)
2. VLAN table is dedicated for Service Provider domain VLAN control. (The VID used to index the VLAN table is Service Provider Control for packet forwarding and learning operation, and the untag control can strip SP\_Tag only.)
3. With the Double Tagging (QinQ) process being performed, the VLAN translation operations are performed concurrently, either through the ingress VLAN remapping operations, or through the CFP action with the egress VLAN remapping operations.
4. Local CPU generated packets (incoming packets through IMP port with Broadcom tag) have options to preserve the untagged status or to be processed as normal input packets.

Figure 9 shows how the extra (SP) tag is added to the incoming packets (tagged or untagged), and how the added tag can be output as is or be replaced.

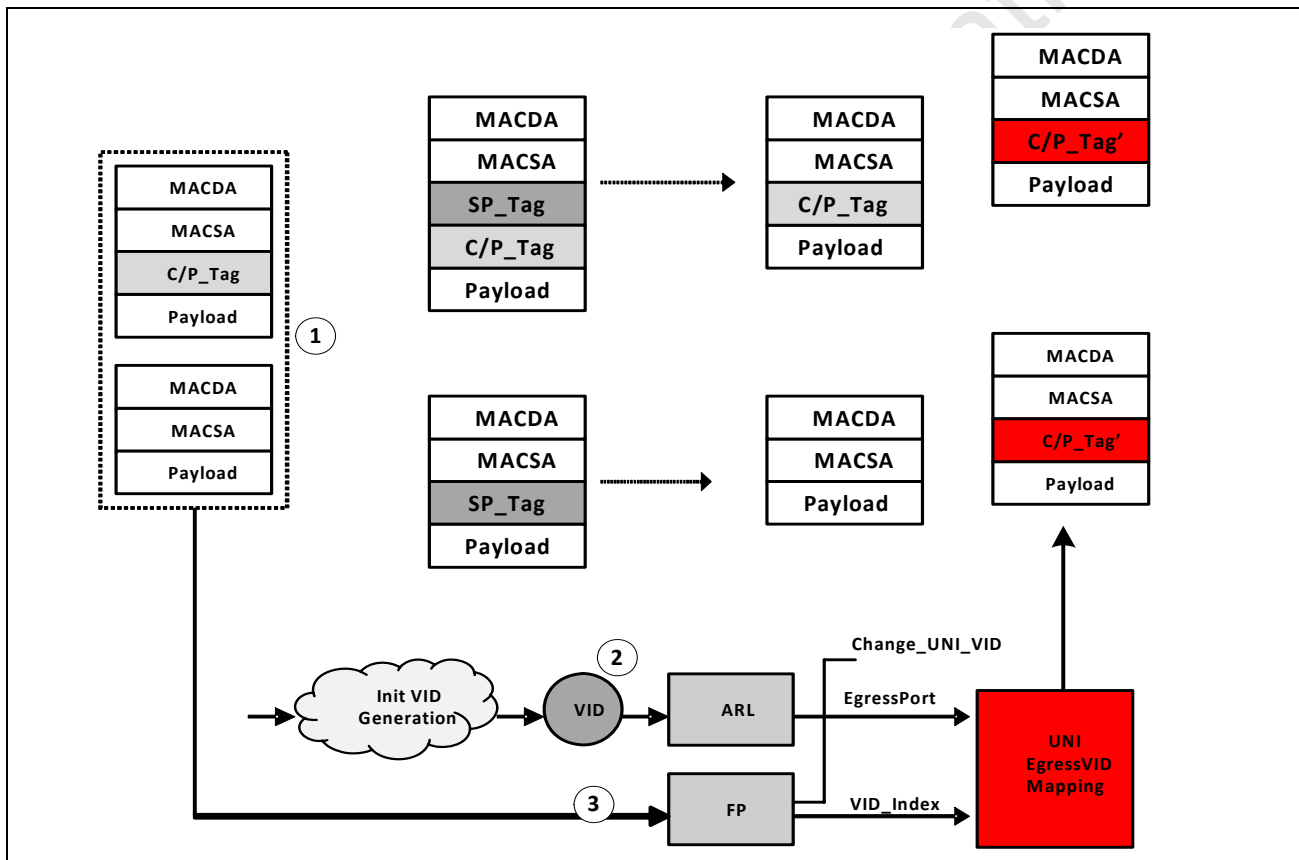

Figure 9: UNI to UNI

In **Non\_Double Tagging** mode, the following definitions will be used throughout the description of the Non-Double Tagging operation. See Figure 10.

- All Ethernet ports are treated same (as if they are all UNI ports).
- Incoming packets can be Untagged, Priority tagged, or C tagged. (SP-tagged packets are not supposed to be forwarded across an UNI link.)

- The VLAN Table is dedicated for Customer domain VLAN control. (The VID used to index the VLAN Table is Customer’s property for packet forwarding and learning operations)
- Local CPU-generated packets have option to preserve the CPU intended untag status.
- The VLAN translation operation may be performed, either through the ingress VLAN remapping operations or through the CFP action with the egress VLAN remapping operations.

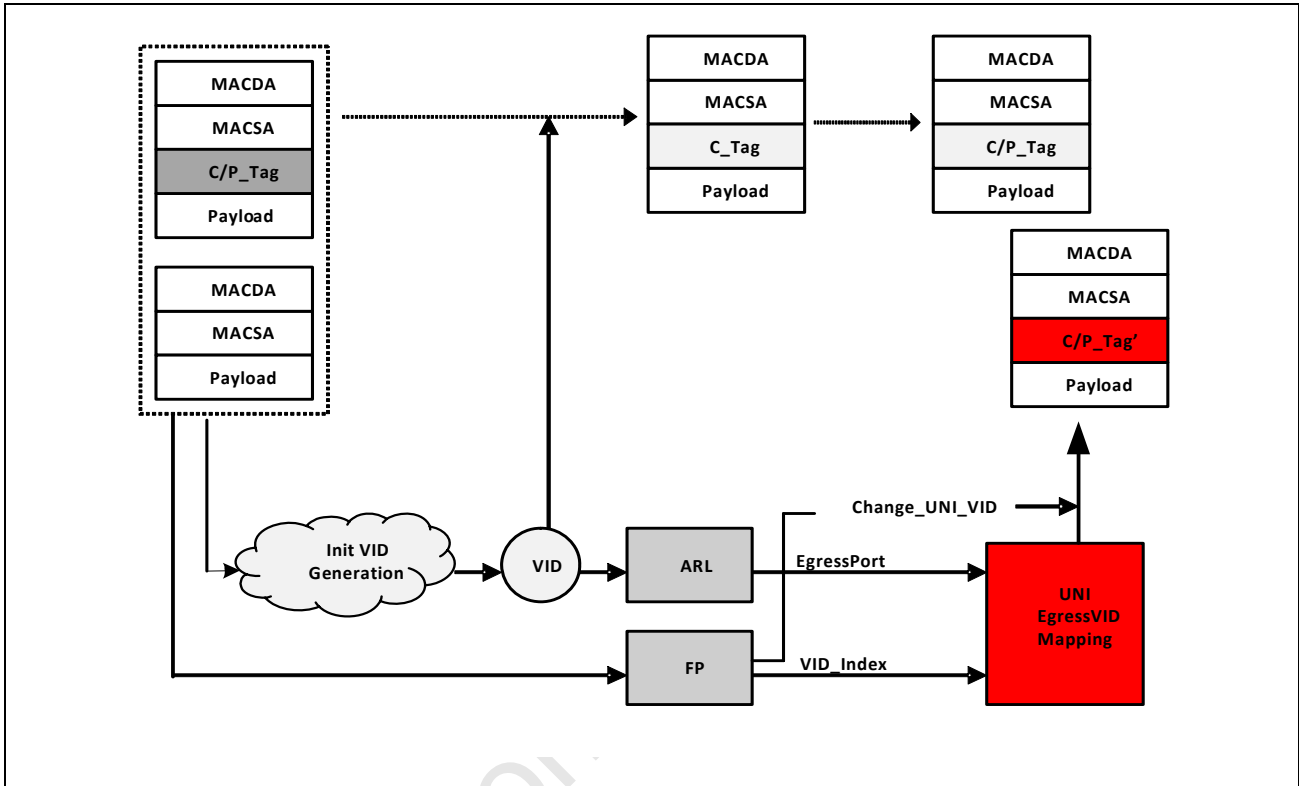

Figure 10: Non\_Double Tagging Mode UNI to UNI

## Link Aggregation

The BCM53242M supports MAC-based aggregation. The aggregation feature allows up to eight ports to be grouped together as a single-link connection between two switch devices. This increases the effective bandwidth through a link and provides redundancy. BCM53242M allows up to 14 aggregation groups. Aggregations are composed of predetermined ports and can be enabled via a register. Ports within an aggregation group must be of the same linked speed. By performing a dynamic hashing algorithm on the MAC address, each packet destined for the aggregation is forwarded to one of the valid ports within the aggregation group. This method has several key advantages. By dynamically performing this function, the traffic patterns can be more balanced across the ports within an aggregation. In addition, the MAC-based algorithm provides dynamic failover. If a port within an aggregation group fails, the other ports within the aggregation automatically assume all traffic designated for the aggregation. It allows for a seamless, automatic redundancy scheme. This hashing function can be performed on either the DA, SA, IPv4DA, IPv4SA, or any combination of four depending on the Aggregation Hash Selector bit.

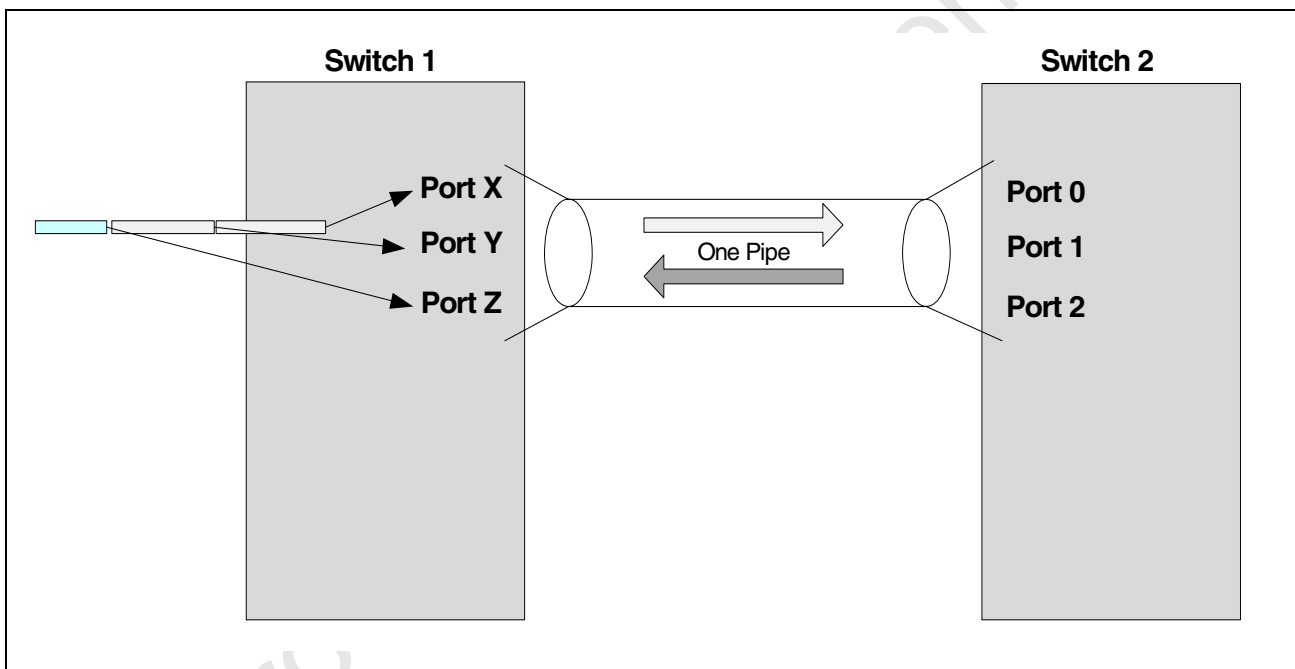

Figure 11: Link Aggregation

---

## Rate Control

Forwarding broadcast traffic consumes switch resources, which can negatively impact the forwarding of other traffic. The rate-based broadcast storm suppression mechanism is used to protect regular traffic from an over abundance of broadcast or multicast traffic. This feature monitors the rate of ingressed traffic of programmable packet types. If the rates of these packet types exceed the programmable maximum rate, the packets are dropped or flow control is activated.

The broadcast storm mechanism works on a credit-based rate system that figuratively uses a bucket to track the bandwidth of each port (see [Figure 12 on page 53](#)) on the basis of egress or ingress data flow. Credit is continually added to the bucket at a programmable Bucket Bit Rate. Credit is decremented from the bucket whenever one of the programmable packet types is ingressed at the port. If no packets are ingressed for a considerable length of time, the bucket credit will continue to increase up to a programmable maximum bucket size. If a heavy burst of traffic is suddenly ingressed at the port, the bucket credit will become drained. When the bucket is emptied, incoming traffic will be constrained to the Bucket Bit Rate, the rate at which credit is added to the bucket. At this point, excess packets will be either dropped or deterred via flow control.

## Egress Rate Control

The egress rate control employs a single bucket system to track the bandwidth usage of all egressed packets. Each port has the queue structure as shown in [Figure 2 on page 38](#), each queue has a shaper can control the egress rate, and each port has a shaper can control the egress rate per port basis. The simple but effective method can be enabled on a per-port and per queue basis with a granularity of 64Kbps.

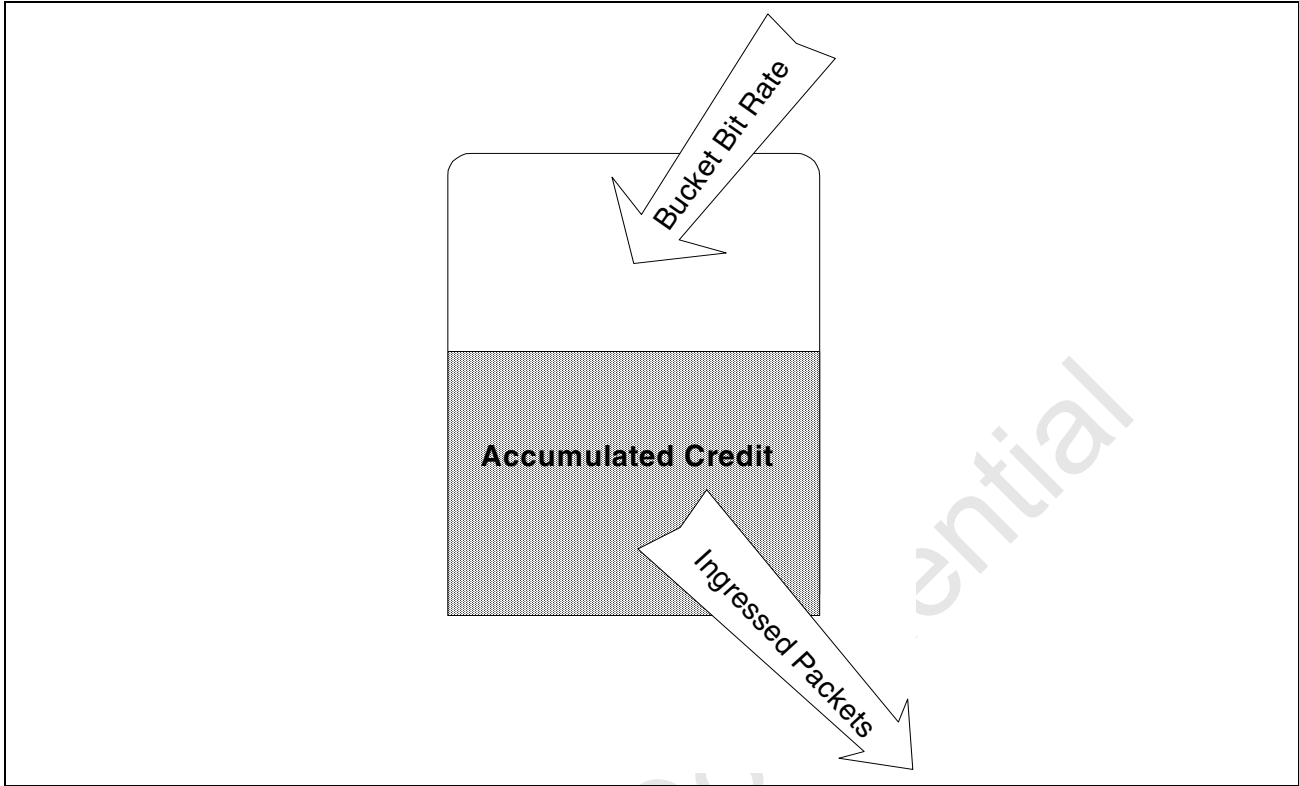

Figure 12: Ingress Bucket Flow

## Ingress Rate Control: The Three-Bucket System

For added flexibility, the BCM53242M ingress rate control employs three buckets to track the rate of ingressed packets. Each of the three buckets, Bucket 0, Bucket 1, and Bucket 2, can be programmed to monitor different packet types. For example, Bucket 0 could monitor broadcast packets, while Bucket 1 and Bucket 2 monitor other types of packets. Multiple packet types can be monitored by each bucket, and a packet type can be monitored by both buckets.

The rates of each bucket can be programmed individually. For example, the broadcast packets of Bucket 0 could have a maximum rate of 3 Mbps, whereas the multicast packets of Bucket 1 could be allowed up to 80 Mbps, with the granularity of each bucket at 64 Kbps. The size of each bucket can be programmed individually as well. This determines the maximum credit that can accumulate in each bucket. The bucket rate can be specified as an absolute rate or a normalized rate, which is scaled to the link speed of the given ingress port. The rate control can be enabled or disabled on a per-port basis.

---

## Protected Ports

The Protected Ports feature allows certain ports to be designated as protected. All other ports are unprotected. Traffic between protected port group members is blocked. However, protected ports are able to send traffic to unprotected ports. Unprotected ports can send traffic to any port. There are the following application benefits:

- **Aggregator:** All of the available ports are designated as protected ports, except a single aggregator port. All traffic incoming to the protected ports will not be sent within the protected ports group. Any flooded traffic is forwarded only to the aggregator port.
- To prevent unsecured ports from monitoring important information on a server port, the server port and unsecured ports are designated as protected. The unsecured ports will not be able to receive traffic from the server port.

## Port Mirroring

The BCM53242M supports port mirroring, allowing ingress and/or egress traffic to be monitored by a single port that is defined as mirror capture port. The mirror capture port can be any 10/100 port, 10/100/1000 port or the Management port. The BCM53242M can be configured to mirror the ingress traffic and/or egress traffic of any other port(s). Mirroring multiple ports is possible, but can create congestion at the mirror capture port. Filtering can be used to decrease the port congestion. In addition, each ingress port can be configured to randomly pick the received packets and send to the CPU for Sflow packet sampling purpose.

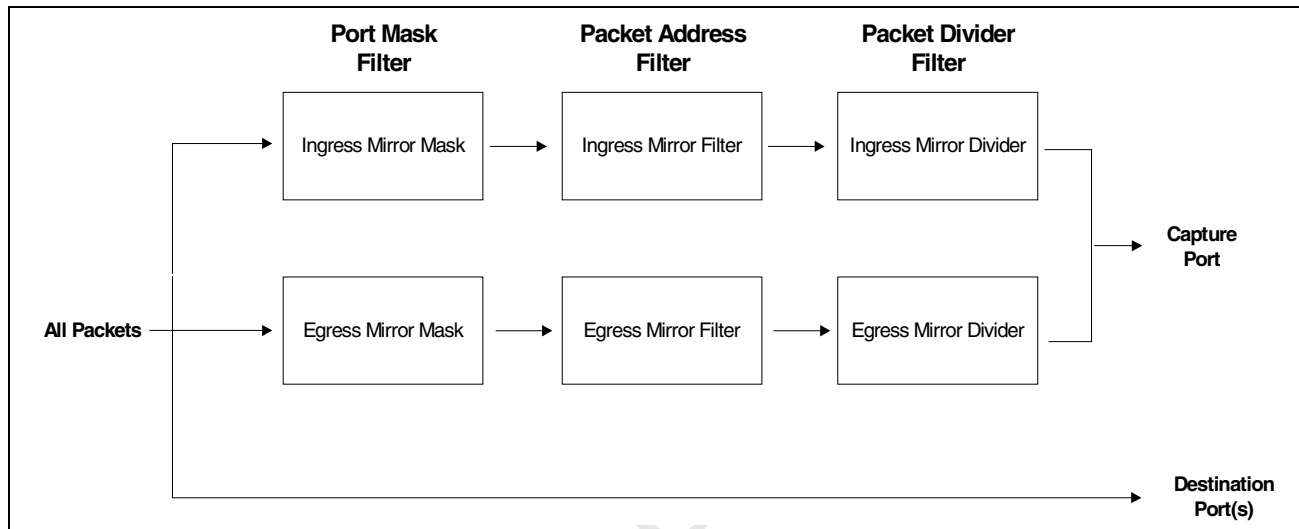

Figure 13: Mirror Filter Flow

## Mirror Filtering Rules

Mirror Filtering Rules consist of a set of three filter operations

- “Port Mask Filter”
- “Packet Address Filter”
- “Packet Divider Filter” on page 56

### Port Mask Filter

The most basic of filtering, the Port Mask filter, allows for the selection of a limited number of ports to be monitored based on egress or ingress packet flow. Any number of ingress/egress ports can be programmed to be mirrored, but bandwidth restrictions on the one mirror capture port should be taken under advisement, so as not to cause congestion or packet loss.

### Packet Address Filter

The Packet Address filter further filters the mirrored ingress/egress frames based on the following criteria:

- Mirror all received frames

- Mirror received frames with DA = x
- Mirror received frames with SA = x

Where x is programmed 48-bit MAC address.

## Packet Divider Filter

The Packet Divider filter allows further statistical sampling to be performed. Only one out of every n ingress/ egress frames is forwarded to the mirror capture port, where n is a programmable integer. Combined with the packet address filter it allows the following capabilities:

- Mirror every n<sup>th</sup> received frame
- Mirror every n<sup>th</sup> received frame with DA = x
- Mirror every n<sup>th</sup> received frame with SA = x

---

## IGMP and MLD Snooping

The BCM53242M supports IP layer IGMP and MLD Snooping. When IGMP and MLD is enabled, the BCM53242M forwards IGMP and MLD frames to the frame management port. The external management entity programs the multicast membership information to the ARL table.

When the IP layer IGMP and MLD snooping is enabled, a frame with a value of 2 in the IP header protocol field and not a IGMP query will be forwarded to the CPU port. The Management CPU can then determine, from the IGMP control packets, which port should participate in the multi group session. The management CPU proactively programs the multicast address in the ARL table or the Multiport Address Entries.

---

## Jumbo Frame Support

The BCM53242M can receive and transmit frames of extended length on all linked ports. Referred to as jumbo frames, these packets may be longer than 1518 bytes (when untagged), up to 2048 bytes. This feature is automatically enabled upon power up.

---

## 802.1x Port-Based Security

IEEE 802.1x is a port-based authentication protocol based on the exchange of Extensive Authentication Protocol over LAN (EAPOL) packets. When enabled the BCM53242M 802.1x feature forwards these packet types to the management CPU. Based on the receipt of these packets, the management CPU has the prerogative to modify per-port 802.1x-based security status.

When 802.1x feature is enabled, all traffic is blocked except EAPOL and ARP frames. The default state for all switch ports is a nonforwarding state. As ports become authenticated via the management CPU, these port states are modified via the CPU. Thus packet forwarding can commence.



---

## Dynamic Secure MAC Mode

Another security feature that can be used in with the 802.1x feature, the Dynamic Secure MAC Mode allows the management CPU control of the dynamic Source Address (SA) learning process. When enabled, the maximum number of learned SA ARL entries is set. When this maximum has been reached, the learning process is no longer active. Incoming frames with an unknown source address will be dropped without dynamically learning them into the ARL table. The learning process will continue when the aging process removes existing learned entries from the ARL table. This feature does not account for statically programmed ARL entries via the management CPU.

---

## Address Management

The BCM53242M Address Resolution Logic contains the following features:

- Two bins per bucket address table configuration.
- Hashing of the MAC/VID address to generate the address table pointer.

The address management unit of the BCM53242M provides wire-speed learning and recognition functions. The address table supports 8K unicast/multicast addresses using on-chip memory.

## Address Table Organization

The MAC addresses are stored in embedded SRAM. Each bucket contains two entries (or bins). The address table has 4K buckets.

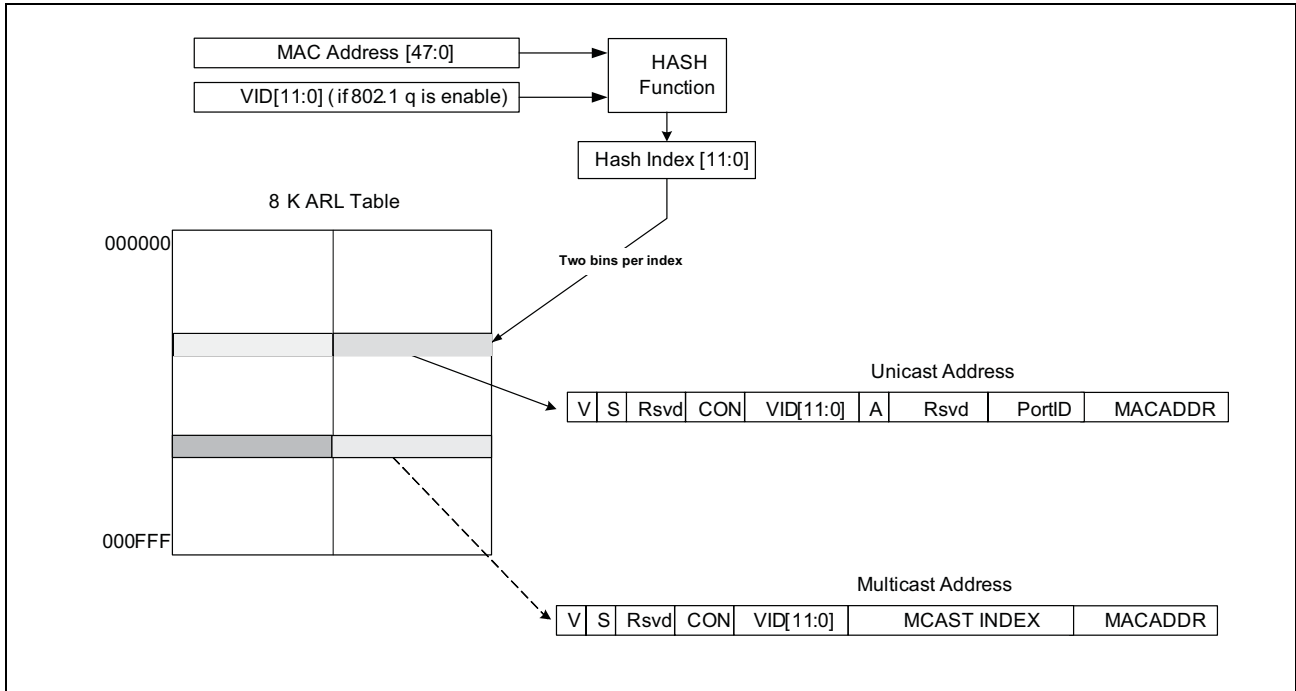

**Figure 14: BCM53242M Address Table Organization**

The index to the address table is computed using a hash algorithm based on the MAC address and the VLAN ID (VID) if enabled. The hash algorithm uses the CRC-CCITT polynomial. The input to the hash is reduced to a 16-bit CRC hash value. Bits 11:0 of the hash are used as an index to the 4K buckets of the address table.

The CRC-CCITT polynomial is:

$$x^{16} + x^{12} + x^5 + 1$$

## Address Learning

Information is gathered from received unicast packets, and learned or stored for the future purpose of forwarding frames addressed to the receiving port. During the receive process the frame information, such as the source address (SA) and VID, is saved until completion of the packet. An entry is created in the ARL table memory if the following conditions are met:

- The packet has been received without error
- The packet is of legal length
- The packet has a unicast SA
- If using 802.1Q VLAN, the packet is from a SA that belongs to the indicated VLAN domain
- The packet does not have a reserved multicast destination address
- There is free space available in memory to which the hashed index points.

When unicast packets are dynamically learned, the VALID bit is set, the AGE bit is set, and the STATIC bit is cleared in the entry.

## Reserved Addresses

The BCM53242M treats certain of the 802.1 administered reserved multicast destination addresses in specific ways, dependent on the mode of operation. Packets identified with these destination addresses are handled uniquely since they are designed for special functions.

**Table 2: Behavior for Reserved Multicast Addresses**

<b>MAC Address</b>	<b>Function</b>	<b>802.1 Specified Action</b>	<b>Unmanaged Mode Action (Note 1)</b>	<b>Managed Mode Action</b>
01-80-C2-00-00-00	Bridge Group Address	Drop Frame	Forward Frame	Forward Frame to Frame Management Port Only (Note 2)
01-80-C2-00-00-01	IEEE Std 802.3x MAC Control Frame	Drop Frame	Receive MAC Determines if Valid PAUSE Frame and acts accordingly	Receive MAC Determines if Valid PAUSE Frame and acts accordingly
01-80-C2-00-00-02	RESERVED	Drop Frame	Drop Frame	Forward Frame to Management Port Only
01-80-C2-00-00-03	RESERVED	Drop Frame	Drop Frame	Forward Frame to Management Port Only
01-80-C2-00-00-04~ 01-80-C2-00-00-0F	RESERVED	Drop Frame	Drop Frame	Forward Frame to Management Port Only
01-80-C2-00-00-10	All LANs Bridge Management Group Address	Forward Frame	Forward Frame	Forward Frame to all Ports Including Frame Management Port
01-80-C2-00-00-20	GMRP address	Forward Frame	Forward Frame	Forward Frame to all Ports Except Frame Management Port (Note 3)
01-80-C2-00-00-21	GVRP address	Forward Frame	Forward Frame	Forward Frame to all Ports Except Frame Management Port (Note 3)
01-80-C2-00-00-22~ 01-80-C2-00-00-2F	RESERVED	Forward Frame	Forward Frame	Forward Frame to all Ports Except Frame Management Port

**Table 2: Behavior for Reserved Multicast Addresses (Cont.)**

<b>MAC Address</b>	<b>Function</b>	<b>802.1 Specified Action</b>	<b>Unmanaged Mode Action (Note 1)</b>	<b>Managed Mode Action</b>
Note:				
1. Unmanaged Mode disables the frame management port option. The IMP does not receive frame data when in this mode. The MII port will be treated as a normal network port and have frames forwarded to it in accordance with the entries in the address table.				
2. Frames with the reserved multicast address corresponding to the BridgeGroup Address (01-80-C2-00-00-00) are forwarded to the programmed Frame Management Port based on the contents of the BPDU Multicast Address Register (in the ARL Control Register Page). Changing this register from the default value causes frames with the new address to be forwarded to the Frame Management Port, and BPDUs are flooded to all ports except the Frame Management Port. The RX_BPDU_EN bit of Management Configuration Register must be enabled.				
3. Frames with the reserved multicast address corresponding to the GMRP or GVRP Addresses (01-80-C2-00-00-20 or 01-80-C2-00-00-21) are forwarded to all ports except the source and Frame Management Ports. If the switch product implements either of these protocols, then the BCM53242M should be programmed to use the Managed Mode, and the multicast address should be instantiated in the address table, with a Port ID that forwards the frame to the chip and port with the defined Frame Management Port.				

## Learning

During the receive process the source address (SA) of the packet is saved until completion of the packet. The address is stored in the address table memory if the following conditions are met:

- The packet is not from the Management port.
- The packet has been received without error.
- The packet is of legal length.
- The packet has a unicast address.
- There is a free space available in one of the two entries (STATIC=0 and VALID=0) in the bucket that the hashed address indexes to. If there is no free space available in the bucket, the address is not learned.

When learning, the MAC address and the source port ID is stored into the address table. The VALID bit is set, the AGE bit is set, and the STATIC bit is reset in the entry.

## Static Address

The BCM53242M supports static filtering entries that are created and updated by software through the Serial Management Port. Bridge management software can create these entries by directly writing the entry location of the buffer memory, and setting the STATIC bit of the entry. Static entries do not have new MAC addresses or port associations learned automatically, and are not aged out by the automatic internal aging process (i.e., the AGE bit is subject to aging and refreshing processes, however, the entry can only be invalidated by CPU.).

For instance, addresses associated with a switch's network ports and the management port should be instantiated as Static entries in the address table by the management processor, with the source port ID and as the physical management port. All the specific register information is temporary and subject to be change in the final version of the data sheet.

## Resolution

The destination address (DA) of the received packet is used by the address resolution function to search the address table and assign a destination port for the packet. The destination port is assigned by locating a matching address in the address table and selecting the source port identifier field as the destination port. The search for a matching address occurs only for unicast packets. The address resolution function for unicast packets proceeds as follows:

- The lower 12 bits of the DA are used as a pointer into the address table memory and both entries in the bucket are retrieved. The address resolution logic processes the two entries in parallel.
- If the valid indicator is set and the address stored at one of the locations matches the DA of the packet received, the port identifier is assigned to be the destination port of the packet.
- If the destination port matches the source port, the packet is not forwarded.
- If the valid indicator is not set or the address stored does not match the DA address of the packet, the packet is forwarded as a broadcast packet and will be transmitted to all other ports.

If SW\_FWDG\_MODE is Unmanaged, packets with the group address bit set in the DA are handled as follows:

- If the DA matches the globally assigned multicast address of the 802.3x MAC Control PAUSE frame of 01-80-C2-00-00-01, the packet is not forwarded.
- If the DA matches the Bridge Group Address, the packet is forwarded to all ports except the source port.
- If the DA matches one of the other globally assigned reserved address (between 01-80-C2-00-00-02 and 01-80-C2-00-00-0F), the packet is not forwarded.
- All other multicast and broadcast packets are forwarded to all ports except the source port and the Management Port.

If SW\_FWDG\_MODE is Managed, packets with the group address bit set in the DA are handled as follows:

- If the DA matches the globally assigned multicast address of the 802.3x MAC control PAUSE frame of 01-80-C2-00-00-01, the packet is not forwarded.
- If the DA matches one of the globally assigned reserved address (between 01-80-C2-00-00-00 and 01-80-C2-00-00-0F excluding 802.3x MAC Control PAUSE frame address), the packet is forwarded to the Management port.
- If the DA matches the All LANs Bridge Management Group Address of 01-80-C2-00-00-10, or the GARP addresses of 01-80-C2-00-00-20 to 01-80-C2-00-00-2F, the packet is forwarded to all ports except the source port and the Management Port.
- All other multicast and broadcast packets are forwarded to all ports except the source port. The Management Port can selectively have broadcast packets and/or multicast packets individually disabled based on the RX\_MCST\_DISABLE and RX\_BCST\_DISABLE bits in the Port Control Register for the IMP (MII).

## Hash Function

The address resolution logic incorporates a hash function to randomize storage location for the MAC address.

## ARL Mishs Options

When an ARL miss occurs, the BCM53242M allows for the programming of two registers to decide what to do with the ARL missed packet:

- MLF\_FWD\_MAP is for Multicast packet
- ULF\_FWD\_MAP is for unicast packet

When a unicast ARL miss occurs, the BCM53242M forwards it according to the ULF\_FWD\_MAP value. When a Multicast ARL miss occurs, the BCM53242M forwards it according to the MLF\_FWD\_MAP value.

Broadcom Confidential

---

## Bridge Management

BCM53242M provides the following services:

- 802.1D—Spanning Tree Protocol
- 802.1s—Multiple Spanning Trees
- 802.1W—Rapid Reconfiguration of Spanning Tree
- Bridge Management state register access through the CPU interface
- Bridge Protocol Data Unit (BPDU) frame forwarding through the CPU interface or the MII interface

### Spanning Tree Port State

The BCM53242M device supports the Spanning Tree Protocol (STP) by providing the spanning tree state in the Port Control Register for each of the network ports. Each Port Control Register (PCR) contains three bits dedicated to STP state (STP\_STATE[2:0]) as well as additional bits to control the operation of the MAC port.

In the unmanaged compatible mode of operation (SW\_FWDG\_MODE = Unmanaged), the default state of the STP\_STATE[2:0] bits are all 0s, and no spanning tree state is maintained. Write operations to the spanning tree state bits are ignored. Frames are forwarded based only on their DA. Known unicast address frames are forwarded to their single defined destination port, and unknown unicast, as well as all multicast/broadcast addressed frames, are flooded to all ports, with the exception of the management port, providing SW\_FWDG\_EN = 1. BPDU frames, are one of the 802.1 reserved multicast addresses that the unmanaged mode floods.

The BCM53242M reacts to the STP state bits as written by the management CPU, as described in the following sections (providing SW\_FWDG\_EN = 1).

#### Disable

In this state, all frames received by the port are discarded. The port also does not forward any transmit frames, queued by either BCM53242M receive network ports, or frames cast by the management entity via the IMP. Addresses are not learned by ports in the Disabled state. This is the default state that the BCM53242M will power up in when SW\_FWDG\_MODE = Managed.

#### Blocking

In this state, the MAC port forwards received BPDUs to the designated Management port (IMP). All other frames received by the port are discarded and the addresses are not learned. The port will also not forward any transmit frames, queued by other BCM53242M receive network ports.

## Listening

In this state, the MAC port forwards received BPDUs to the designated Management port (IMP). All other frames received by the port are discarded and the addresses are not learned. The port also does not forward any transmit frames, queued by other BCM53242M receive network ports, but transmits frames cast by the management entity, via the MSP or IMP, as expected (such as BPDUs). Note that the Learning and Listening states of all BCM53242M ports are identical. The external management processor running the STP algorithm must distinguish these two states using the STP algorithm, but is able to store the Learning and Listening state information into the BCM53242M for consistency.

## Learning

In this state the MAC port forwards received BPDUs to the Management port, transmits BPDUs sent into the Management port, and learns MAC addresses. All other frames received by the port are discarded.

## Forwarding

In this state the MAC port forwards received BPDUs to the Management port, transmits BPDUs sent into the Management port, forwards all other frames and learns all incoming frame's MAC addresses.

**Table 3: Spanning Tree State**

<b>Spanning Tree State</b>	<b>Receive BPDU</b>	<b>Transmit BPDU</b>	<b>Normal Frame</b>	<b>Learning State</b>	<b>STP_State</b>
No Spanning Tree OR Spanning Tree Disable	Treated as Multicast	Flood to all ports	Forward	Learn	000
Disable State	Disabled	Disabled	Don't Forward	Don't Learn	001
Blocking State	Forward to Management	Disabled	Don't Forward	Don't Learn	010
Listening State	Forward to Management	Enabled	Don't Forward	Don't Learn	011
Learning State	Forward to Management	Enabled	Don't Forward	Learn	100
Forwarding State	Forward to Management	Enabled	Forward	Learn	101

The Multiple Spanning Tree Protocol (MSTP), which uses the Rapid Spanning Tree protocol (RSTP) to provide rapid convergence, enables VLANs to be grouped into a spanning-tree instance, provides for multiple forwarding paths for data traffic, and enables load balancing. It improves the fault tolerance of the network because a failure in one instance (forwarding path) does not affect other instances (forwarding paths). The most common initial deployment of MSTP and RSTP is in the backbone and distribution layers of a Layer 2 switched network; this deployment provides the highly-available network required in a service-provider environment. Both RSTP and MSTP improve the operation of the spanning tree while maintaining backward compatibility with equipment that is based on the (original) 802.1D spanning tree. The BCM53242M can support up to 256 Spanning Trees.



The BCM53242M also supports per-port aging.

## Management Frames

Management frames received by the BCM53242M are forwarded to the Bridge Management entity (an external CPU or microcontroller) through the GMII/MII Port. When the GMII/MII is used as the interface to the external management subsystem the port is referred to as the In-band Management Port (IMP). When operating in the unmanaged mode, management frames are treated differently. The following frames are forwarded to the Bridge Management entity in the BCM53242M mode:

- **BPDU Frames**—BPDUs are identified by the Bridge Group Address (01-80-C2-00-00-00) in the destination address field of a frame. The STP\_STATE bits in the Port Control Register must be configured to permit BPDU reception on a particular port. A BPDU received on such a port will be forwarded, with the Port ID of the receiving port, to the port configured in the Management Port ID register.
- **Reserved Multicast Addressed Frames**—Frames with 802.1 administered Reserved Multicast Addresses (between 01-80-C2-00-00-02 and 01-80-C2-00-00-0F in their DA field) are forwarded only to the Management Port, with a header which includes the Port ID of the port from which the frame was received. Frames with the All LANs Bridge Management Group Address (01-80-C2-00-00-10) as the DA are forwarded to all ports, with the Management Port again receiving the header information to identify the Port ID from which the frame was received.
- **Directed Management Agent Frames**—Packets with the DA equal to one of the MAC addresses associated with the Management Port. These addresses are generally entered as Static addresses by the management entity itself.
- **Mirrored Frames**—Ingress or egress port frames that have been assigned to be mirrored to the management port.

---

## Compact Field Processor

BCM53242M provides a TCAM based Compact Field Processor (CFP) to support ACL implementation and packet classification. CFP is a versatile filter and classification processor.

There are three CFP slices running in parallel in BCM53242M as shown in [Figure 15 on page 66](#). As a result, multiple ContentAware processing can be executed per packet. The each CFP slice consists of Parser, Lookup Engine, Policy Engine, Metering/Statistic Engine, and Action Resolution Logic.

The input (key) to the CFP includes the predefined fields from the packet header, and/or user-defined fields within a packet. All these inputs are gathered at the receive port through the parser.

Up to 1K rules can be set for the parallel engines to search and assign the action to be taken when a match has been discovered. These rules can be distributed over the input ports in any combination. The actions supported by the BCM53242M are flooding, dropping, copying, changing the forward port map, adding forward port, and changing the priority, VID, and DSCP of a frame. The details of the actions are described in later paragraph.

Each CFP Engine (slice) consists of a Parser, a Lookup engine, a Policy engine, a Metering and Statistic engine and an Action Resolution engine.

- **Parser** assembles and extracts specified Ethernet standard field data and/or user-configurable UDF field data. Then, the Parser makes the assembled key available to the lookup engine. BCM53242M has

predefined key fields for each of three slices as shown in [Table 4 on page 70](#), [Table 5 on page 70](#), [Table 6 on page 72](#), and [Table 7 on page 72](#). The most well known packet header fields may be selected, as well as any field in the packet through User-Defined Field (UDF).

- Lookup engine, which performs lookup and outputs the address of the matched location. Lookup engine compares the input (combination of fields defined in each slice) with all the entries in the TCAM memory. The result of the comparison is the address for the entry that is 100 percent matched. If there is more than one matching entry, the entry with the lowest physical address is returned. In addition, the lookup engine also has a mask per entry that selects specific bits of each memory entry that are required to be an exact match with the incoming bits from the input. This provides flexibility by allowing the Don't Care fields in the input.
- Policy engine, which contains a list of actions for the matching rule in the ContentAware lookup engine. There are as many actions as rules. Each matching index from the Lookup Engine is mapped to an action in the Policy engine.
- Metering and Statistics engines, which perform policing and statistics collection.
- Action resolution engine, which resolves multiple/conflict matches. Based on the matching results from the Lookup Engine, three possible actions from each slice are input to the Action Resolution Logic. The priority of each slice can be configured. The Action Resolution Logic sorts out the each action from each slice, and implements all the non conflicting actions. For the conflicting actions, the Action Resolution Logic picks an action from the high-priority slices.

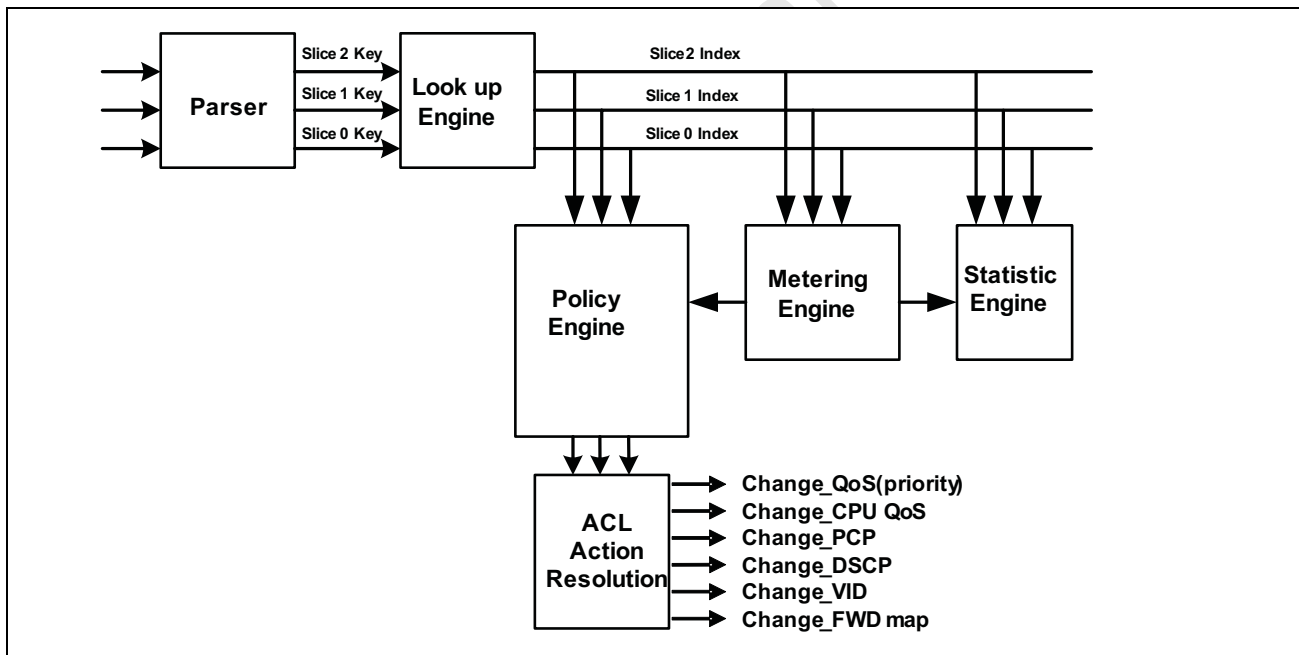

Figure 15: CFP Engines

## Parser

The parser parses for standard Ethernet fields, as well as, user-defined fields. [Figure 16](#) shows standard packet format. The parser recognizes the following predefined fields:

- EtherType (ETYPE, 16 bits)

- L2 Known Field
  - Destination MAC address (MAC\_DA, 48 bits)
  - Source MAC address (MAC\_SA, 48 bits)
  - Outer (Service Provider) Tag (TPID 1, 16 bits)
  - Inner (Customer) Tag (TPID2, 16 bits)
- L3 Known Field (IPv4)
  - Destination IP address (IP\_DA, 32 bits)
  - Source IP address (IP\_SA, 32 bits)
  - DSCP field (DSCP [6 bits] and CU [2 bits])
  - IP protocol field (IP\_PROTOCOL, 8 bits)
  - TTL Range (2 bits)
  - Same IP address (Same\_IPAddr, 1 bit)
- L3 Known Field (IPv6)
  - Flow ID (FlowID, 20 bits)
  - Source IP address (IP\_SA, 32 bits)
  - Traffic Class (8 bits)
  - Next Header (8 bits)
  - Hop Limit Range (HopLimit\_Range, 2bits)
  - Same IP address (Same\_IPAddr, 1 bit)
- L4 Known Field (TCP/UDP)
  - Destination Port (DST\_port, 16 bits)
  - Source Port (SRC\_Port, 16 bits)
  - TCP flags (TCP\_FLAG, 6 bits)  
SYN, FIN, ACK, FRAG, RST, PSH
  - Same L4 Port (Same\_L4Port, 1 bit)
  - L4 Source less than 1024 (L4SRC\_Less1024, 1 bit)
  - TCP Sequence number zero (TCP\_Seq\_Zero, 1 bit)
  - The length of TCP Header is less than min (MIN\_TCP\_Header, 1 bit)
- L4 Known Fields (ICMP/IGMP)
  - Type (8 bits)
  - Code (8 bits)
  - Max\_ICMP (1 bit)
- Range Field
  - BCM53242M supports eight ranger mechanism: four rangers are used to detect the range of C-VID of received packets, and four rangers are used to detect the rage of TCP/UDP port of received packets. All rangers are globally configurable in terms of range setting and DST/SRC checking.
    - C\_VLAN Range (4 bits): Each bit indicates whether the C\_VID of the received packet falls into the corresponding range.
    - L4\_Port Range (4 bits): Each bit indicates whether the L4 (DST/SRC) port of the received TCP/UDP packet falls into the corresponding range.

- User-Defined Field
  - User-define field A0 ... A2 (UDF A, 16-bits wide) used for slice 0
  - User-define field B0 ... B10 (UDF B, 16-bits wide) used for slice 1
  - User-define field C0 ... C2 (UDF C, 16-bits wide) used for slice 2
  - User-define field D0 ... D7 (UDF D, 32-bits wide) used for slice 2
  - The four Offset parameters are used to define the location of particular UDF field within the packet. They are defined in the UDF definition registers.
  - End of Tag
  - End of EtherType
  - End of IP Header

Broadcom Confidential

MAC DA[47:16]			
MAC DA[15:0]		MAC SA[47:32]	
MAC SA[31:0]			
[BRM TAG] 8874		IMP PORT INFO	
IMP PORT INFO			
[ISP TAG] 9100 (default)		PRI	0
		USR VID	
[1Q TAG] 8100		PRI	0
		ISP VID	
Length[15:0]		DSAP=AA	
		SSAP=AA	
		DSAP	
		SSAP	
Data(no parsing)			
Control=03		org	
Control		Data(no parsing)	
ETYPE (0800)		Version	IHL
		DiffServ	
ETYPE (86dd)		Version	Traffic Class
		Flow Label	
ETYPE (888e)		Protocol version(1)	
		Packet Type	
Total Length		Identification	
Fragment offset		TTL	Protocol
Header checksum		Source IP [31:16]	
Source IP [15:0]		Destination IP [31:16]	
Destination IP [15:0]		Source port [15:0]	
Destination port [15:0]		Sequence number [31:16]	
Sequence number [15:0]		Acknowledge number [31:16]	
Acknowledge number [15:0]		HL	FLAGS
Windows			

Figure 16: Standard Packet Format

## Lookup Engine

The lookup engine is a highly flexible TCAM. This table contains fully user-programmable entries. Each entry has its individual corresponding mask. CFP implements three fixed rule templates, which are called Slice 0, Slice 1 and Slice 2. [Table 4 on page 70](#), [Table 5 on page 70](#), [Table 6 on page 72](#), and [Table 7 on page 72](#) show the slice key field description.

**Table 4: Slice Key Common Fields**

<b>Field</b>	<b>Width (bits)</b>	<b>Bit Position</b>	<b>Description</b>
Slice ID	2	1:0	Indicates the search slice number
Ingress Port Map	29	30:2	Indicates which ingress port(s) the associated ACL rule will apply
SP Tagged	1	31	Indicates whether the received packet is Service Provider tagged.
C Tagged	1	32	Indicates whether the received packet is Customer tagged.
L2 Format	2	34:33	Indicates L2 encapsulation of the received packets: <ul style="list-style-type: none"> <li>• 00: L2_Others</li> <li>• 01: Ethernet_II</li> <li>• 10: IEEE_802_2_SNAP</li> </ul>
L3 Format	2	36:35	Indicates L3 encapsulation of the received packets: <ul style="list-style-type: none"> <li>• 00: L3_Others</li> <li>• 01: IPV4 without fragmentation</li> <li>• 10: IPV6 without extension</li> </ul>
L4 Format	2	38:37	Indicates L4 encapsulation of the received packets: <ul style="list-style-type: none"> <li>• 00: L4_Others. Including IPV4 with fragmentation and IPV6 with extension fields.</li> <li>• 01: TCP</li> <li>• 10: UDP</li> <li>• 11: ICMP/IGMP</li> </ul>
Range Field	8	42:39	VLAN range
		46:43	L4 src/dst port range

**Table 5: Slice 0 Key Field Definition**

<b>Field</b>	<b>Width (bits)</b>	<b>Bit Position<sup>a</sup></b>	<b>Description</b>
Slice Common Field	47	46:0	Shown in Slice Common Field table (see <a href="#">Table 4</a> )
L2 Known Field	128	94:47	Destination MAC address (MAC_DA, 48 bits)
		142:95	Source MAC address (MAC_SA, 48 bits)
		158:143	Outer (Service Provider) Tag (TPID 1, 16 bits)
		174:159	Inner (Customer) Tag (TPID2, 16 bits)
Ether Type	16	190:175	–

**Table 5: Slice 0 Key Field Definition (Cont.)**

<b>Field</b>	<b>Width (bits)</b>	<b>Bit Position<sup>a</sup></b>	<b>Description</b>	
L3 Known Field	83	–	IPv4	
			222:191	• Destination IP address (IP_DA, 32 bits)
			254:223	• Source IP address (IP_SA, 32 bits)
			262:255	• DSCP (6 bits) and CU (2 bits)
			270:263	• IP protocol field (IP_PROTOCOL, 8 bits)
			272:271	• TTL Range (2 bits)
			273	• Same IP Address (Same_IPAddr, 1 bit)
L3 Known Field	83	–	IPv6	
			212:191	• Flow ID (FlowID, 20 bits)
			254:213	• Source IP address (IP_SA, 32 bits)
			262:255	• Traffic Class (8 bits)
			270:263	• Next Header (8 bits)
			272:271	• Hop Limit Range (HopLimit_Range, 2 bits)
			273	• Same IP address (Same_IPAddr, 1bit)
L4 Known Field	42	–	TCP/UDP	
			289:274	• Destination Port (DST_port, 16 bits)
			305:290	• Source Port (SRC_Port, 16 bits)
			311:306	• TCP flags (TCP_FLAG, 6 bits)
			–	– SYN, FIN, ACK, FRAG, RST, PSH
			312	• Same L4 Port (Same_L4Port, 1 bit)
			313	• L4 Source less than 1024 (L4SRC_Less1024, 1 bit)
			314	• TCP Sequence number zero (TCP_Seq_Zero, 1 bit)
			–	ICMP/IGMPMax_ICMP (1 bit)
			297:290	• Type (8 bits)
			305:298	• Code (8 bits)
			315	• Max_ICMP Check (1 bit)
UDF_A0_Valid, UDF_A0	17	332:316	–	
UDF_A1_Valid, UDF_A1	17	349:333	–	
UDF_A2_Valid, UDF_A2	17	366:350	–	
Valid	4	383:380	–	

a. All undefined bit positions are reserved.

**Table 6: Slice 1 Key Field Definition**

<b>Field</b>	<b>Width (bits)</b>	<b>Bit Position<sup>a</sup></b>	<b>Description</b>
Slice Common Field	47	46:0	Shown in Slice Common Field table, <a href="#">Table 4 on page 70</a>
L2 Known Field	128	94:47	Destination MAC address (MAC_DA, 48 bits)
		142:95	Source MAC address (MAC_SA, 48 bits)
		158:143	Outer (Service Provider) Tag (TPID 1, 16 bits)
		174:159	Inner (Customer) Tag (TPID2, 16 bits)
UDF_B0_Valid, UDF_B0	17	191:175	–
UDF_B1_Valid, UDF_B1	17	208:192	–
UDF_B2_Valid, UDF_B2	17	225:209	–
UDF_B3_Valid, UDF_B3	17	242:226	–
UDF_B4_Valid, UDF_B4	17	259:243	–
UDF_B5_Valid, UDF_B5	17	276:260	–
UDF_B6_Valid, UDF_B6	17	293:277	–
UDF_B7_Valid, UDF_B7	17	310:294	–
UDF_B8_Valid, UDF_B8	17	327:311	–
UDF_B9_Valid, UDF_B9	17	344:328	–
UDF_B10_Valid, UDF_B10	17	361:345	–
Valid	4	383:380	–

a. All undefined bit positions are reserved.

**Table 7: Slice 2 Key Field Definition**

<b>Field</b>	<b>Width (bits)</b>	<b>Bit Position<sup>a</sup></b>	<b>Description</b>
Slice Common Field	47	46:0	Shown in Slice Common Field table, see <a href="#">Table 4 on page 70</a> .
UDF_C0_Valid, UDF_C0	17	63:47	–
UDF_C1_Valid, UDF_C1	17	80:64	–
UDF_C2_Valid, UDF_C2	17	97:81	–



**Table 7: Slice 2 Key Field Definition (Cont.)**

<b>Field</b>	<b>Width (bits)</b>	<b>Bit Position<sup>a</sup></b>	<b>Description</b>
UDF_D0_Valid, UDF_D0	33	130:98	–
UDF_D1_Valid, UDF_D1	33	163:131	–
UDF_D2_Valid, UDF_D2	33	196:164	–
UDF_D3_Valid, UDF_D3	33	229:197	–
UDF_D4_Valid, UDF_D4	33	262:230	–
UDF_D5_Valid, UDF_D5	33	295:263	–
UDF_D6_Valid, UDF_D6	33	328:296	–
UDF_D7_Valid, UDF_D7	33	361:329	–
Valid	4	383:380	–

a. All undefined bit positions are reserved.

## Policy Engine

Table 4 on page 70, Table 5 on page 70, Table 6 on page 72, and Table 7 on page 72 contain one entry per lookup engine entry and the actions/policies that should be taken for the lookup engine entry. The policy entry also indicates which metering and counter entries should be used.

There are six types of actions in CFP policy.

1. The forwarding-related action. Change the destination port or add destination port. It can also drop a frame by making new\_dest to 6'b11\_1111 and enable change destination.
2. To change the priority of the frame. The priority queue can be specified to use by setting PRI\_MAP accordingly.
3. To change the QoS of the outgoing packets.
4. To change the QoS of the CPU originated packets.
5. To change the DSCP tag of the outgoing packets.
6. To change the VID of the outgoing packets.

All six operations can be asserted in parallel, so it is possible that in the end of ContentAware processing, assign to a specific priority and also copy to CPU port and update the corresponding counter.

## Packet Remarking

BCM53242M supports Packet Remarking. Remarks can be made on the PCP field of the outmost VLAN tag of the outgoing packet, or remarks can be made on the DSCP field if the outgoing packet is an IP packet. The remarking process is a part of the ChangePCP, and the ChangeDSCP actions from the CFP, and carried over through the MMU as a part of the packet descriptor information. Based on the new DSCP value, the corresponding IP checksum is also re calculated. The Remarking information is applied globally, independent to the Egress port.

## VID Replacement

BCM53242M supports VID Replacement. The VID field of the outmost VLAN tag of the outgoing packet can be replaced. The Replacement feature is port dependent, each port can be setup differently. Each Egress port supports a 16 entry FLOW to VID mapping table which is indexed by the FlowID. This is derived as a part of the ChangeVID action from the CFP, and is carried through the MMU as a part of the packet descriptor information.

One of the applications for this feature is in the IPTV distribution where the common Multicast VLAN can be dynamically associated with different subscriber's VLANs.

## Metering Engine

Metering engine provides the ability to control ingress bandwidth based on packet classification. Metering determines whether a packet is inband or outband. The results of the metering engine is fed back to the policy engine for determining which actions should be processed.

## Statistic Engine

The Statistics engine increments the counters based on the metering results. For each rule, there are in-profile and out-profile counters counting packets (not bytes).

## ACL Action Resolution Block

The Action Resolution engine collects the information (action and metering results) from the hit entries: if more than one rule matches, the actions and meter/counters are taken from the policy associated with the matched rule with highest priority.

## Section 3: System Functional Blocks

---

### Overview

The BCM53242M includes the following functional blocks:

- “Media Access Controller”
- “Integrated PHY” on page 77
- “Frame Management” on page 88
- “Switch Controller” on page 93
- “Integrated High-Performance Memory” on page 94
- “Clocking” on page 94
- “MIB Engine” on page 94

Each are discussed in more detail in the following sections.

---

### Media Access Controller

The MAC automatically selects the appropriate speed, CSMA/CD or Full-duplex, based on the PHY auto-negotiation result. In FDX mode, 802.3x PAUSE-frame-based flow control is also determined through auto-negotiation. The MAC is IEEE 802.3, 802.3u, and 802.3x compliant.

### Receive Function

The MAC initiates frame reception following the assertion of receive data valid indication from the physical layer. The MAC monitors the frame for the following error conditions:

- Receive error indication from the PHY
- Runt frame error if frame is fewer than 64 bytes
- CRC error
- Long frame error if frame is greater than 2048 bytes (Rev. A silicon)
- For revision B silicon, long frame error if frame is greater than MAX\_RX\_LIMIT, which is defined in “[New Control Register \(Page 00h/Addr 03h\)](#)” on page 157.

If no errors are detected, the frame is processed by the switch controller. Frames with errors are discarded. Receive functions can be disabled.

## Transmit Function

Frame transmission begins with the switch controller queuing a frame to the MAC transmitter. The frame data is transmitted as received from the switch controller. The transmit controller is responsible for preamble insertion, carrier deferral, collision backoff, and inter-packet gap enforcement.

In 10/100 half-duplex mode, when a frame is queued for transmission, the transmit controller behaves as specified by the 802.3 requirements for frame deferral. Following deferral, the transmitter adds 8 bytes of preamble and SFD to the frame data received from the switch controller. If, during frame transmission, a collision is observed and the collision window timer has not expired, the transmit controller asserts jam and then executes the backoff algorithm. The frame is retransmitted when appropriate. On the sixteenth consecutive collision, the backoff algorithm starts over at the initial state, the collision counter is reset and attempts to transmit the current frame continue. Following a late collision, the frame is aborted and the switch controller is allowed to queue the next frame for transmission.

While in full-duplex mode, the transmit controller ignores carrier activity and collision indication. Transmission begins after the switch controller queues the frame and the 96 bit-times of IPG have been observed. Transmit functions can be disabled.

## Flow Control

The BCM53242M implements an intelligent flow control algorithm to minimize the system impact resulting from traffic congestion. Buffer memory allocation is adaptive to the status of each port's speed and Duplex mode, providing an optimal balance between flow management and per-port memory depth. The BCM53242M initiates flow control in response to buffer memory conditions on a per-port basis.

The MACs are capable of flow control in both full-and half-duplex modes.

### 10/100 Mbps Half-Duplex

In 10/100 Half-duplex mode, the MAC backpressures a receiving port by transmitting a 96-bit time-jam packet to the port. A single jam packet is asserted for each received packet for the duration of the time the port is in the flow control state.

### 10/100/1000 Mbps Full-Duplex

Flow control in full-duplex mode functions as specified by the IEEE 802.3x requirements. In the receiver, MAC flow control frames are recognized and, when properly received, set the flow control pause time for the transmit controller. The pause time is assigned from the 2-byte pause time field following the pause opcode. MAC control PAUSE frames are not forwarded from the receiver to the switch controller.

When the switch controller requests flow control, the transmit controller transmits a MAC control PAUSE frame with the pause time set to maximum. When the condition that caused the flow control state is no longer present, a second MAC control PAUSE frame is sent with the pause time field set to 0.

The flow control capabilities of the BCM53242M are enabled based on the results of auto-negotiation and the state of the ENFDXFLOW and ENHDXFLOW control signals loaded during reset. Flow control in half-duplex mode is independent of the state of the link partner's flow control (802.3x) capability. See [Table 8](#) for more information.

**Table 8: Flow Control Modes**

<b>Link Partner Flow Control (802.3x)</b>	<b>Control Input ENFDXFLOW</b>	<b>Control Input ENHDXFLOW</b>	<b>Auto-Negotiated Link Speed</b>	<b>Flow Control Mode</b>
X	X	0	Half-Duplex	Disabled
X	X	1	Half-Duplex	Jam Pattern
0	0	X	Full-Duplex	Disabled
0	1	X	Full-Duplex	Disabled
1	0	X	Full-Duplex	Disabled
1	1	X	Full-Duplex	IEEE 802.3x Flow Control

## Integrated PHY

The PHY is the ethernet transceiver that appropriately processes data presented by the MAC into an analog data stream to be transmitted at the MDI interface, and performs the reverse process on data received at the MDI interface. The registers of the PHY are read/written to via the programming interface. The following sections describe the operations of the internal PHY block.



**Note:** The 24 integrated transceivers are referred to in this document as ports 24, 25 ... and 47. Broadcom SDK maps these ports to logical ports 0, 1 ... 23 respectively.

## Encoder

In 10Base-T mode, Manchester encoding is performed on the data stream that is transmitted on the twisted-pair cable. The multimode transmit digital-to-analog converter (DAC) performs pre-equalization for 100m of Category-3 cabling.

In 100Base-TX mode, the PHY transmits a continuous data stream over the twisted-pair cable. The transmit packet is encapsulated by replacing the first 2 nibbles of preamble with a start-of-stream delimiter (/J/K/ codes) and appending an end-of-stream delimiter (/T/R/ codes) to the end of the packet. The transmitter repeatedly sends the idle (/i/ code) between packets. The encoded data stream is serialized and then scrambled by the stream cipher block. The scrambled data is then encoded into MLT3 signal levels.

## Decoder

In 10Base-T mode, Manchester decoding is performed on the data stream.

In 100Base-TX mode, following equalization and clock recovery, the receive data stream is converted from MLT3 to serial nonreturn to zero (NRZ) data. The NRZ data is descrambled by the stream cipher block, as described later in this document. The descrambled data is then deserialized and aligned into 5-bit code groups. The 5-bit code groups are decoded into 4-bit data nibbles. The start-of-stream delimiter is replaced with preamble nibbles, and the end-of-stream delimiter and idle codes are replaced with 0h. The decoded data is driven onto the internal MAC interface. When an invalid code group is detected in the data stream, the PHY asserts the internal MII receive error signal. This signal is also asserted when the link fails or when the descrambler loses lock during packet reception.

## Link Monitor

In 10Base-T mode, a link-pulse detection circuit constantly monitors the TRD± pins for the presence of valid link pulses.

In 100Base-TX mode, receive signal energy is detected by monitoring the receive pair for transitions in the signal level. Signal levels are qualified using squelch detect circuits. When no signal is detected on the receive pair, the link monitor enters the Link Fail state and the transmission and reception of data packets is disabled. When a valid signal is detected on the receive pair for a minimum of 1 ms, the link monitor enters link-pass state and the transmit and receive functions are enabled.

## Digital Adaptive Equalizer

The digital adaptive equalizer removes intersymbol interference (ISI) created by the transmission channel media. The equalizer accepts sampled unequalized data from the analog-to-digital converter (ADC) on each channel and produces equalized data. The PHY achieves optimum signal-to-noise ratio by using a combination of feed forward equalization (FFE) and decision feedback equalization (DFE) techniques. Under harsh noise environments, these powerful techniques achieve a bit error rate (BER) of less than  $1 \times 10^{-12}$  for transmissions up to 100m on Category-5 twisted-pair cabling (100m on Category-3 UTP cable for 10Base-T mode). The all-digital nature of the design drives high noise-tolerant performance. The filter coefficients are self-adapting to accommodate varying conditions of cable quality and cable length.

## Analog-to-Digital Converter

Each receive channel has its own 125-MHz analog-to-digital converter (ADC) that samples the incoming data and feeds the output to the digital adaptive equalizer. Advanced analog circuit techniques achieve the following results:

- Low offset
- High power-supply noise-rejection
- Fast settling time
- Low bit-error-rate

## Clock Recovery/Generator

The clock recovery and generator block creates the transmit and receive clocks for 100Base-TX and 10Base-T operation.

In 10Base-T or 100Base-TX mode, the transmit clock is locked to the 25-MHz crystal input, and the receive clock is locked to the incoming data stream.

## Baseline Wander Correction

100Base-TX data streams are not always DC-balanced. Because the receive signal must pass through a transformer, the DC offset of the differential receive input can vary with data content. This effect, which is known as baseline wander, can greatly reduce the noise immunity of the receiver. The PHY automatically compensates for baseline wander by removing the DC offset from the input signal, thereby significantly reducing the probability of a receive symbol error.

In 10Base-T mode, baseline wander correction is not performed because the Manchester coding provides perfect DC balance.

## Multimode TX Digital-to-Analog Converter

The multimode transmit digital-to-analog converter (DAC) transmits PAM5, MLT3, and Manchester coded symbols. The transmit DAC performs signal wave shaping that decreases the unwanted high-frequency signal components, reducing electromagnetic interference (EMI). The transmit DAC uses a current drive output that is well-balanced, and therefore, produces very low noise transmit signals.

## Stream Cipher

In 100Base-TX mode, the transmit data stream is scrambled to reduce radiated emissions and to ensure that there are adequate transitions within the data stream. The scrambler reduces peak emissions by randomly spreading the signal energy over the transmit frequency range and eliminating peaks at certain frequencies. The randomization of the data stream also assists the digital adaptive equalizers and echo/crosstalk cancelers. The algorithms in these circuits require there to be no sequential or cross-channel correlation among symbols in the various data streams.

In 100Base-TX mode, the transmit data stream is scrambled by exclusive ORing the encoded serial data stream. This is done with the output of an 11-bit wide linear feedback shift register (LFSR), producing a 2047-bit nonrepeating sequence.

The receiver descrambles the incoming data stream by exclusive ORing it with the same sequence generated at the transmitter. The descrambler detects the state of the transmit LFSR by looking for a sequence representing consecutive idle code groups. The descrambler locks to the scrambler state after detecting a sufficient number of consecutive idle codes. The BCM53242M enables transmission and reception of packet data only when the descrambler is locked. The receiver continually monitors the input data stream to ensure that it has not lost synchronization by checking that inter-packet gaps containing idles or frame extensions are received at expected intervals.

In 10Base-T mode, scrambling is not required to reduce radiated emissions.

## Wire Map and Pair Skew Correction

During 10/100-Mbps operation, pair swaps are corrected. Delay skew is not an issue though, because only one pair of wires is used in each direction.

## Internal Loopback Mode

When enabled in this mode, all packets egressed to the integrated PHY ports are looped back internally from the TXD signals to the RXD signals. The transmitter outputs TRD± are set to high impedance, and incoming packets on the cable are ignored.

## Isolate Mode

The PHY can be isolated from the internal MAC interface. When the transceiver is put into Isolate mode, all inputs from the MAC block are ignored, and all outputs to the MAC block are tristated. While in Isolate mode, the PHY still sends out link pulses or FLPs, depending on whether the PHY was configured for Forced or Auto-negotiation mode. A link is established if the link partner is forced or is advertising the same technologies. Clearing the same bit removes the device from Isolate mode.

## PHY Registers

Each transceiver within the BCM53242M contains a complete set of PHY registers. The 5-bit transceiver address is assigned correspondingly to the internal port ID. All PHY registers can be accessed through the MDC and MDIO signals, or through the Serial Peripheral Interface.

## 100Base-FX Fiber Mode

The 10/100 port can be configured to operate in 100Base-FX compatible mode. The following sequence is required for configuring the preferred PHY ports to 100Base-FX-compatible operation using register write from the CPU. Each port's register can be programmed through page A0h-B7h, respectively.

1. Write 2100h to register (Pages A0h-B7h, Address 00h-01h). This forces the port to 100M full-duplex without auto-negotiation. Most FX applications require configuration for full-duplex.
2. Set bits 9 and 5 of register (Pages A0h-B7h, Address 20h-21h). This bypasses the scrambler and descrambler blocks (i.e., these scrambling functions are not required for 100Base-FX operation). Other bits within this register may be set, so it is best to perform a read-modified write to ensure proper setting of this register.
3. Set bit 5 of hidden register (Page A0h-B7h, Address 2Eh-2Fh). This changes the three-level MLT-3 code transmitted by the PHY to two-level binary, suitable for driving standard fiber transceivers. Additionally, the PHY receiver is configured to recognize binary signaling. This register access must also be in the form of a read-modified write.
4. Enable Internal EFX Signal Detect Function:
  - a. Write 008Bh to register (Pages A0h-B7h, Address 3Eh-3Fh).
  - b. Write 0200h to register (Pages A0h-B7h, Address 32h-33h).
  - c. Write 0084h to register (Pages A0h-B7h, Address 3Ah-3Bh).



- d. Write 000Bh to register (Pages A0h-B7h, Address 3Eh–3Fh).
5. Configure Full-duplex Pause Capability by setting bit 63 and relevant port bits[47:24] of the Software Flow Control registers (Page 00H, Address 48h).

Refer to the *Enhanced-FX-AN1XX 100Base-FX-Compatibility Application Note* for the FX termination requirement.

## Cable Analyzer Registers and Programming

Cable diagnostics can be initiated at any time by entering certain parameters in the required register bits and then setting the *start* bit. Once the start bit is set, the PHY starts the cable diagnostics and looks for opens, shorts, cable lengths on pair-A and pair-B. When this analysis is completed, it records the results and resets the start bit.

### Shadow Register Description

All of the required bits for the cable analyzer are located in the shadow registers, in particular shadow registers (Pages A0h-B7h, addresses 26h and 28h). Within address 26h, there are eight subregisters 0x26-0, 0x26-1, 0x26-2, 0x26-3, 0x26-4, 0x26-5, 0x26-6, and 0x26-7.

Shadow register 0x26-n is accessed by writing an index value (n = 000b to 111b) to the shadow register at address 28h. To access shadow register 0x26-1, the index value in shadow register 28h must be set to 1. Whenever an access is made (either a read or a write) to shadow register 26h, the index value in the shadow register 28h is automatically incremented.

When changing a bit within any register, preserve the existing values of reserved bits by performing a 'read modify' write.

The following tables shows the cable analyzer registers and their contents.

**Table 9: Shadow Register 28h (Pages A0h-B7h, Address 28h)**

Address	15–11	10–8	7–0	Default
0x28	Reserved	0x26 index	Reserved	0x0000

### 0x26 Index [10:8]

To access shadow register 26h, first an index value from 0(000b) to 7(111b) must be written to these bits. When an access (either read or write) is made to shadow register 26h, this value automatically increments by 1 (111b after the increment, it becomes 000b).

**Table 10: Shadow Register 0x26–0 (Pages A0h-B7h, Address 26h)**

Address	15–14	13–12	11–10	9–8	7–6	9–3	2	1	0	Default
0x26-0	Reserved	Pair-B State	Pair-A State	Pass	Error	Reserved	Start	MP	Reserved	0x0000

## Pair-B State[13:12]

After the completion of cable analyzer, these bits indicate the status of pair-B of the cable (see [Table 11](#) for details). Pair-B of the cable is the pair that is connected to RD± of the device.

**Table 11: Pair-B State**

Value	Result for Pair-B
00b	No fault detected
01b	Pair is open
10b	Pair is short
11b	Reserved

 **Note:** When the cable analyzer function returns a value of 00 (No fault detected), then the attached cable is good. If the device is unable to establish a valid link, the problem is not related to the cable.

## Pair-A State[11:10]

After the completion of cable analyzer, these bits indicate the status of pair-A of the cable (see [Table 12](#) for details). Pair-A of the cable is the pair that is connected to TD± of the device.

**Table 12: Pair-A State**

Value	Result for Pair-A
00b	No fault detected
01b	Pair is open
10b	Pair is short
11b	Reserved

 **Note:** When the cable analyzer function returns a value of 00 (No fault detected), then the attached cable is good. If the device is unable to establish a valid link, the problem is not related to the cable.

## Start [2]

Setting this bit to a 1 starts the cable diagnostics function in the BCM5325EBCM5325F. This should be the last bit that is set after programming the required values in shadow registers 0x26-0, 0x26-1, 0x26-2, 0x26-3, 0x26-4, 0x26-5, 0x26-6 and 0x26-7. This bit is cleared when the cable analyzer function is complete. Once this bit is set, it is reset in approximately 5 ms.

## MP [1] = 1

This is an internal variable required to be set before starting the cable analyzer. Set this bit to a 1.

## Pass [9:8]

These bits are 11b when reading the results of the cable analyzer.

## Error [7:6]

These bits must be 00b when reading the results of the cable analyzer.

**Table 13: Shadow Register 0x26-1 (Pages A0h-B7h, Address 26h)**

Address	15–8	7–0	Default
0x26-1	Pair-B length	Pair-A length	0x0000

## Pair-B Length [15:8]

These bits indicate the length of pair-B once the cable analyzer is completed. To convert this value to meters, multiply the value by 0.8. This value should be used in combination with the result posted on the condition of pair-B in bits [13:12] of shadow register 0x26-0.

**Table 14: Pair-B Cable Diagnostics Result**

Pair-B state [13:12] (shadow register 0x26-0)	Pair-B length [15:8] (shadow register 0x26-1)
01b	Distance at which an open is detected in pair-B
10b	Distance at which a short is detected in pair-B

## Pair-A Length [7:0]

These bits indicate the length of pair-A once the cable analyzer is completed. To obtain the value in meters, multiply this value by 0.8. This value should be used in combination with the result posted on the condition of pair-A in bits [11:10] of shadow register 0x26-0.

**Table 15: Pair-A Cable Diagnostics Result**

Pair-A state [11:10] (shadow register 0x26-0)	Pair-A length [7:0] (shadow register 0x26-1)
01b	Distance at which an open is detected in pair-A
10b	Distance at which a short is detected in pair-A

**Table 16: Shadow Register 0x26-2 (Pages A0h-B7h, Address 26h)**

Address	15–14	13–12	11–10	9–6	5	4–0	Default
0x26-2	GainA	Reserved	TypeA	Reserved	HP	ThresholdA	0x0000

## GainA [15:14] = 01b

This is an internal variable required to be set before starting the cable analyzer. Set these bits to 01b.

**TypeA [11:10] = 10b**

This is an internal variable required to be set before starting the cable analyzer. Set these bits to 10b.

**HP [5] = 1**

This is an internal variable required to be set before starting the cable analyzer. Set these bits to a 1.

**ThresholdA [4:0] = 00100b**

This is an internal variable required to be set before setting the start bit in shadow register 0x26-0 to start the cable analyzer. Set these bits to 00100b.

*Table 17: Shadow Register 0x26-3 (Pages A0h-B7h, Address 26h)*

Address	15–8	7–0	Default
0x26-3	SourceA	Reserved	0x0000

**SourceA [13:8] = 00100000b**

This is an internal variable required to be set before setting the start bit in shadow register 0x26-0 to start the cable analyzer. Set these bits to 00100000b.

*Table 18: Shadow Register 0x26-4 S (Pages A0h-B7h, Address 26h)*

Address	15–11	10	9	8–6	5–0	Default
0x26-4	Reserved	TypeB	Reserved	TPG	Reserved	0x0000

**TypeB [10]**

This is an internal variable required to be set before starting the cable analyzer. Set this bit to a 1.

**TPG [8:6]**

This is an internal variable required to be set before starting the cable analyzer. Set this bit to 100b.

*Table 19: Shadow Register 0x26-5 (Pages A0h-B7h, Address 26h)*

Address	15–14	13–5	4–2	1–0	Default
0x26-5	GainB	Reserved	ThresholdB	Reserved	0x0400

**GainB [15:14 = 11b]**

This is an internal variable required to be set before starting the cable analyzer. Set these bits to 11b.

### ThresholdB [4:2] = 001b

This is an internal variable required to be set before setting the start bit in shadow register 0x26-0 to start the cable analyzer. Set these bits to 001b.

**Table 20: Shadow Register 0x26-6 (Pages A0h-B7h, Address 26h)**

Address	15–14	13–8	7–0	Default
0x26-6	Reserved	SourceB	Reserved	0x0000

### SourceB [13:8] = 000001b

This is an internal variable required to be set before setting the start bit in shadow register 0x26-0 to start the cable analyzer. Set these bits to 000001b.

**Table 21: Shadow Register 0x26-7 (Pages A0h-B7h, Address 26h)**

Address	15–9	8–6	5	4–0	Default
0x26-7	Reserved	PGWB	Reserved	AmpB	0x0000

### PGWB [8:6] = 001b

This is an internal variable required to be set before setting the start bit in shadow register 0x26-0 to start the cable analyzer. Set this bit to a 001b

### AmpB [4:0] = 01100b

This is an internal variable required to be set before setting the start bit in shadow register 0x26-0 to start the cable analyzer. Set this bit to a 01100b.

## Programming Example

The following example of code shows a general flow of completing the cable analyzer in the PHY.

Cable Analyzer programming

```

-----
Start
Write register (Pages A0h-B7h, address 3Eh) = 0x008BEnable shadow register
Wait1
Read (Pages A0h-B7h, address 28h) ; Wait here for at least 2 seconds of bit 6 for address 28h to be
at 0. This ensures that there is no energy from the link partner.
Write (Pages A0h-B7h, address 28h) -0x0000
End Wait1
Write register (Pages A0h-B7h, address 26h) = 0x0000
Write register (Pages A0h-B7h, address 28h) = 0x0200;Set access shadow register 26h to 0x26-2
Write (Pages A0h-B7h, address 26h) = 0x4824; 0x26-2
Write (Pages A0h-B7h, address 26h) = 0x4000; 0x26-3
Write (Pages A0h-B7h, address 26h) = 0x0500; 0x26-4
Write (Pages A0h-B7h, address 26h) = 0xC404; 0x26-5
Write (Pages A0h-B7h, address 26h) = 0x0100; 0x26-6
Write (Pages A0h-B7h, address 26h) = 0x004C; 0x26-7
Write (Pages A0h-B7h, address 26h) = 0x8006; 0x26-0 (Start cable diagnostics)
Wait2
    Write (Pages A0h-B7h, address 28h) = 0x0000; Set access to 0x26-0
    Read (Pages A0h-B7h, 1 address 26h) ; Read 0x26-0
    If register 0x26-0 bit [2] = 1 then go to Wait2
Result
Pair-A status = 0x26-0 bit [11:10]
Pair-B status = 0x26-0 bit [13:12]

Read (Pages A0h-B7h, 19h, address 26h) ; Read 0x26-1
Pair-A length = bit [7:0] X 0.8 meters
Pair-B length = bit [15:8] X 0.8 meters

Write register (Pages A0h-B7h, 1address 3Eh) = 0x000BEnable default MII register access
End

```



**Note:** If a port is connected to a link partner with a good cable (no short or no open on either pair) and the link partner is not powered up, then the cable status bits are valid, but the length bits are invalid.

### Cable Analyzer Flow Chart

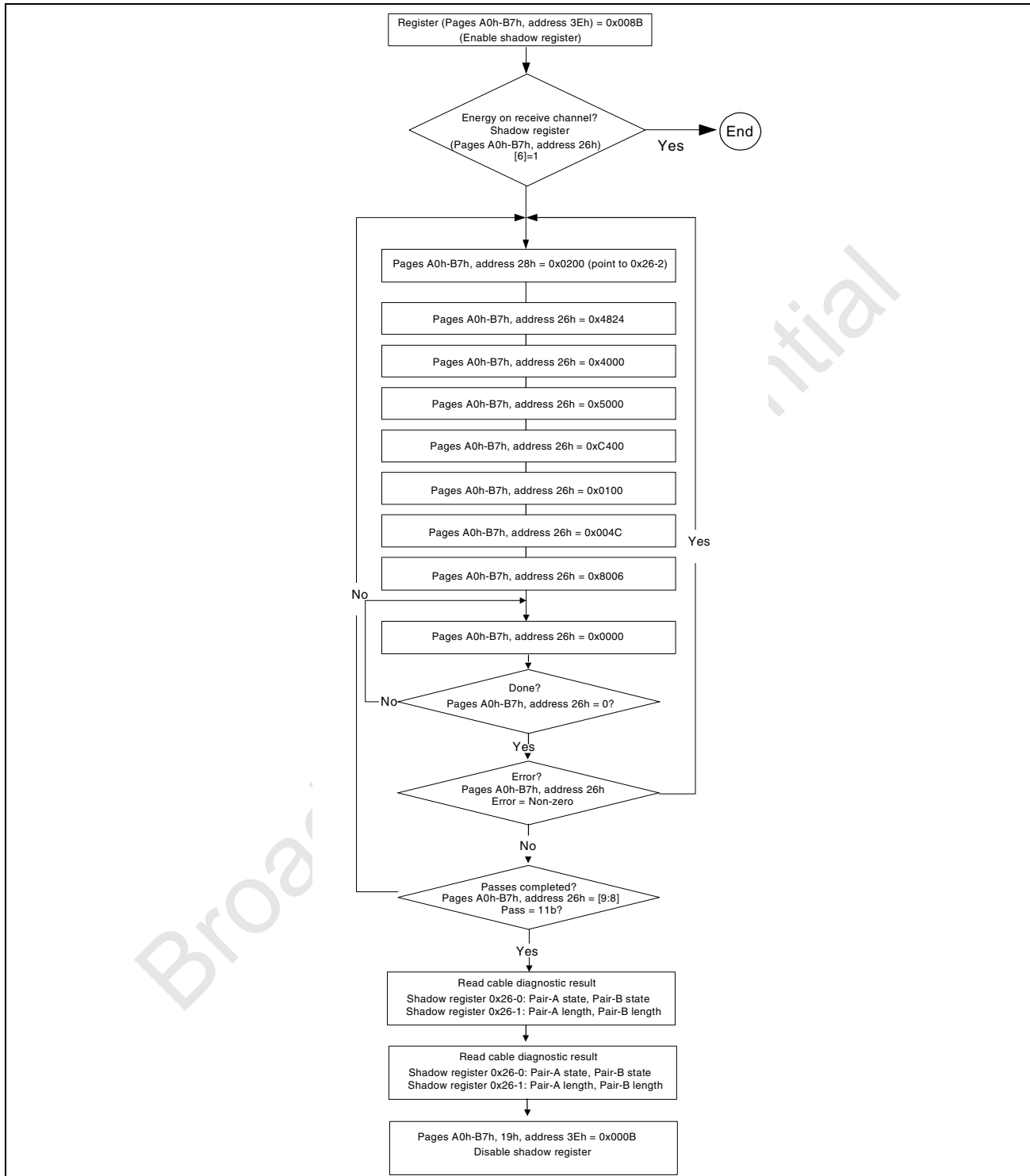

Figure 17: Cable Analyzer Flow Chart

---

## Frame Management

The BCM53242M provides a frame management block that works in conjunction with a selectable port interface to receive forwarded management frames directed to the switch.

The frame management block is configured via the FRM\_MNGT\_PORT bits of the Global Management Configuration register as shown in [Table 98: "Global Management Configuration Register \(Page 03h: Address 00h\)," on page 195](#).

An external CPU connects via the selected port interface to process the forwarded frames and respond appropriately. When the selected port is defined as the Frame Management Port, it is referred to as the In-band Management Port (IMP).

### In Band Management Port

The IMP can be used as a full-duplex port, which can be used to forward management information to the external management agent, such as BPDUs, mirrored frames, or frames addressed to other Static address entries that have been identified as of special interest to the management system.

As IMP is defined as the Frame Management Port, normal frame data is forwarded to the port based on the state of the RX\_UCST\_EN, RX\_MCST\_EN and RX\_BCST\_EN bits in the associated IMP Port Control Register. If these bits are cleared, no frame data will be forwarded to the Frame Management Port, with the exception that frames meeting the Mirror Ingress/Egress Rules criteria, will always be forwarded to the designated Frame Management Port.

The BCM53242M device intrusively tags frames destined to the management entity to allow the identity of the originating ingress port of a frame to be retained. Additional header information is inserted into the original frame, between the original SA field and Type/Length fields, see [Figure 18 on page 89](#). The tag includes the BRCM Type field and the BRCM Tag field. The Broadcom tag type is 0x8874, the alignment of the regenerated FCS may vary depending on the original frame length, and the regenerated FCS covers from the whole frame, including the BRCM Type and BRCM tag. A recalculated FCS is appended to the resultant frame, before the frame is forwarded.



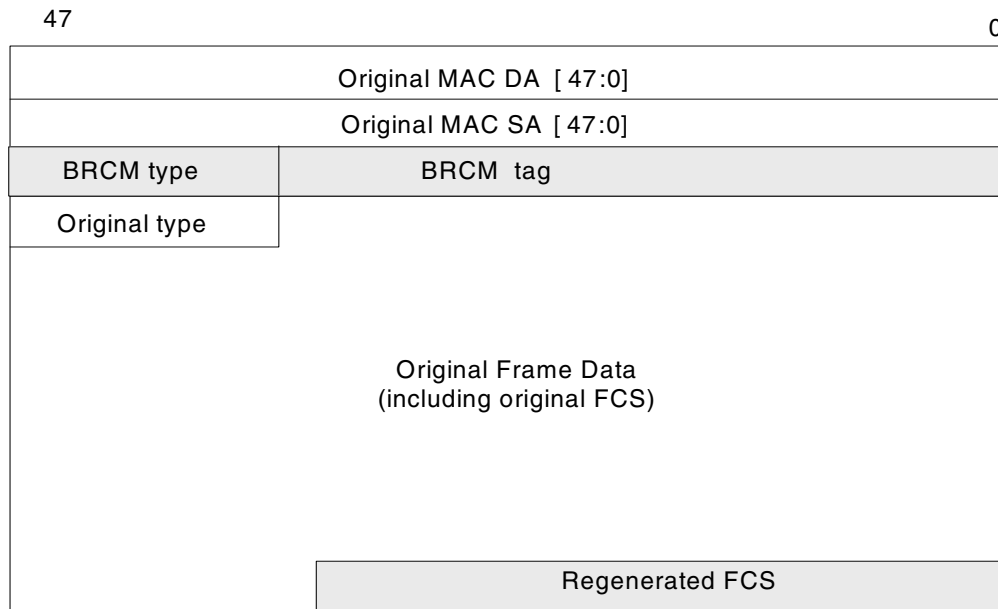

**Figure 18: Broadcom-Tagged Packet Encapsulation Format**

The Broadcom Tag is designed for asymmetric operation across the IMP port. The information carried from the BCM53242M to the external CPU (IMP Egress) is different from the information carried from the external CPU to BCM53242M (IMP Ingress).

Similarly, the host system must insert the BRCM Type/Length and Tag fields into frames it wishes to send into the management port, to be routed to specific egress ports. The OPCODE within the Tag field determines how the frame will be handled, and allows frames to be forwarded using the normal address lookup or via a Port ID designation within the Tag.



**Note:** The FCS (outer) is ignored by the BCM53242M device. However, the management entity is still intended to provide 4 bytes of any data as a place holder. Only the final outgoing FCS (inner) is required.

The BRCM Tag and BRCM Type/Length fields are transmitted with the convention of highest significant octet first, followed by next lowest significant octet, etc., and with the least significant bit of each octet transmitted out from the MAC first. So for the BRCM Type/Length field in [Table 22 on page 90](#), the most significant octet would be transmitted first (bits 24:31), with bit 24 being the first bit transmitted.

## IMP Ingress

[Table 22](#) shows the format of the IMP Ingress BRCM Tag field. The OPCODE field slightly modifies the use and validity of some fields in the Tag. [Table 23](#) defines the supported OPCODEs.

**Table 22: BRCM Header Tag Format (CPU to IMP)**

31-29	28,27	26,25	24 - 6	5-0
Opcode = (000) Unicast/Multicast/ Broadcast	TQ[1:0]	TE[1:0]	Reserved	Reserved
Opcode = (010) Egress Directed	TQ[1:0]	TE[1:0]	Reserved	Dest Portid Indicates the destination Port ID for Egress Directed frames. <b>Note:</b> Setting Dest Portid = 0x30 allows egress directed frame to loopback to CPU. This is for testing purpose.
Opcode = (100) Multicast Egress Directed to 10/100 Ports	TQ[1:0]	TE[1:0]	Dest Port Vector [Port 23~Port 0] Defines the destination Port IDs for Multicast Egress Directed frames. <b>Note:</b> Bit 24 is not used	
Opcode = (101) Multicast Egress Directed to GigaPorts	TQ[1:0]	TE[1:0]		Dest Port Vector [G1, G0, IMP] Defines the destination GigaPort IDs for Multicast Egress direct frames. <b>Note:</b> 1. Bits 4 and 5 are not used. 2. For testing purpose, setting bit[0] = 1 allows the CPU to loop back the frame at the IMP port.

**Table 23: OPCODE Field in BRCM Tag for Management Port Frame**

OpCodes	Name	Description
0 0 0	Unicast/Multicast Broadcast	Normal unicast and multicast frames are forwarded using the address table lookup of the DA contained in the frame. Broadcast frames sent by the host management system into IMP port are forwarded based on the broadcast rule that is in effect.
0 1 0	Egress Directed	An Egress Directed frame is sent by the host management system into the IMP port, and is forwarded to the Egress Port specified in the Destination Port ID fields in the BRCM Tag.
1 0 0	Multicast Egress Directed	A Multicast Egress Directed frame is sent by the host management system into the IMP port and is forwarded to multiple 10/100 Egress Ports specified in the Dest Port Vector field in <a href="#">Table 22 on page 90</a> .
1 0 1	Multicast Egress Directed	A multicast Egress Directed frame is sent by the host management system into the IMP port and is forwarded to multiple Egress ports specified in the Dest Port Vector field in <a href="#">Table 22 on page 90</a> .

**Table 24: TQ and TE Fields in BRCM Tag for Management Port Frame**

<b>Field</b>	<b>Name</b>	<b>Description</b>
TQ[1:0]	Traffic Class Queue	Uses by the host CPU to assign a traffic class queue for forwarding the packet. <ul style="list-style-type: none"> <li>• 11: Highest queue</li> <li>• 10: 3rd queue</li> <li>• 01: 2nd queue</li> <li>• 00: Lowest queue</li> </ul>
TE[1:0]	Tag Enforcement	Used by the host CPU to enforce the 802.1Q/1p tagging/untagging encapsulation of the packet at the egress forwarding of the packet. <ul style="list-style-type: none"> <li>• 11: Reserved</li> <li>• 10: Enforces tagging regardless of the 802.1Q VLAN untag mask</li> <li>• 01: Enforces untagging regardless of the 802.1Q VLAN untag mask</li> <li>• 00: No enforcement. Follows the 802.1Q VLAN untag mask</li> </ul>

## IMP Egress

Table 25 shows the format of the IMP Egress BRCM Tag field. The OPCODE field slightly modifies the use and validity of some fields in the Tag. Table 26 defines the supported OPCODEs.

**Table 25: BRCM Header Tag Format (IMP to CPU)**

<b>31-29</b>	<b>28-17</b>	<b>16</b>	<b>15-14</b>	<b>13 - 8</b>	<b>7,6</b>	<b>5 - 0</b>
Opcode = (000) Unicast Multicast/ Broadcast	Frame Oct Count[11:0] This 11-bit field incorporates the Octet Count of the entire Ethernet frame octet count starting at the DA field and inclusive of CRC, but not including the BRCM Type, BRCM Tag, and recalculated FCS.	RSVD	QoS: Indicates the traffic class queue used in forwarding the packet to CPU	Reason Code[5:0]: Indicates the reason code for the packet to be forwarded to CPU.	ERMON 7: Extended RMON for Ingress 6: Extended RMON for Egress	SRC_PID: Indicates the source Port ID for ingress directed frames.

**Table 26: OPCODE Field in BRCM Tag for Management Port Frame**

<b>OpCodes</b>	<b>Name</b>	<b>Description</b>
0 0 0	Unicast/ Multicast/ Broadcast	Unicast, multicast, reserved multicast and broadcast frames from a network port destined to the host management system are forwarded using the address table lookup of the DA contained in the frames. All frames are automatically inserted a BRCM Tag that includes the Frame Oct Count and Source Port ID fields.

**Table 27: Reason Code Field in BRCM Tag for Management Port Frame**

<b>Reason Code</b>	<b>Name</b>	<b>Description</b>
0	Mirroring	The packet is mirrored to the CPU as the capture port.
1	SA Learning	The packet is forwarded to the CPU for controlled MAC SA learning.
2	Switching/Flooding	The packet is forwarded to the CPU either because of flooding or the CPU is the intended receive host.
3	Protocol Termination	The packet is trapped by the CPU because an IEEE 802.1-defined L2 protocol must be terminated by the CPU.
4	Protocol Snooping	The packet is copied to the CPU because an L3 or application level protocol must be monitored by the CPU for network security or operation efficiency.
5	Exception Processing/Flooding	The packet is trapped and forwarded to the CPU either because of flooding or for some special processing, even though the CPU is not the intended receive host.

---

## Switch Controller

The core of the BCM53242M device is a cost-effective and high-performance switch controller. The controller manages packet forwarding between the MAC receive and transmit ports through the frame buffer memory with a store and forward architecture. The switch controller encompasses the functions of buffer management, memory arbitration and transmit descriptor queuing.

### Buffer Management

The frame buffer memory is divided into 256 bytes per page. Each packet received may allocated more than one page, of which, six pages are required for storing maximum 1536B frame data. Frame data is stored to the memory block as the packet is received. After reception, the frame is queued to the egress port(s) transmit queue. For unicast frames, following transmission of a packet from the frame buffer memory, the block of memory for the frame is released to the free buffer pool. If the frame is destined to multiple ports, the memory block is not released until all ports complete transmission of the frame.

### Memory Arbitration

Processes requesting access to the internal memory include the receive and transmit frame data handlers, address resolution, learning and aging functions, and output port queue managers. These processes are arbitrated to provide fair access to the memory and minimize latency of critical processes to provide a fully nonblocking solution.

### Transmit Output Port Queues

When the Quality of Service (QoS) function is turned off, the switch controller maintains an output port queue for each port. The queue depth becomes smaller for each output port when the QoS function is on. Transmit descriptors are updated after the packet has been received and the destination port resolved. One or two transmit descriptors are assigned to each destination port queue linking the destination with the frame data. For packets which have frame sizes larger than 512 bytes, two transmit descriptors are required. In the case of multicast and broadcast packets, a transmit descriptor for the packet is assigned to the transmit descriptor queues of multiple ports.

For each port, frames are initiated for transmission with minimum IPG until the transmit descriptor queue of the port is empty.

When the QoS is turned on, the single queue is split into four different-sized priority queues. These four queues are maintained by the switch controller for each transmit port. The weighted fair scheduling is applied to the queues to select frames from all queues and prevent starvation.

## Integrated High-Performance Memory

The BCM53242M includes 4 Mb of integrated, high-performance RAM which stores all packet buffer and address table information; and eliminates the need for external memory. This allows for the implementation of extremely low-cost systems.

## Clocking

The BCM53242M uses a single 25-MHz clock input to derive the device's internal clocks to operate at 100 MHz, which affect the operation of the system logic and internal RAM. This allows for the best trade-offs with respect to performance, cost, and power.

## MIB Engine

The MIB Engine is responsible for processing status words received from each port. Based on whether it is a receive status or transmit status, appropriate MIB counters are updated. The BCM53242M implements 70 plus MIB counters on a per-port basis. MIB counters can be categorized into three groups:

- Receive only counters
- Transmit only counters
- Receive or transmit counters

The receive or transmit counters group can, as a group, be selectively steered to the receive or transmit process on a per-port basis. The following section describes each individual counter.

## MIB Counters Per Port

**Table 28: Receive Only Counters (17)**

<b>Counters</b>	<b>Description</b>
RxDropPkts (32 bit)	The number of packets received by a port that were dropped due to security conflict when MAC address security Control is enabled.
RxOctets (64 bit)	The number of bytes of data received by a port (excluding preamble but including FCS), including bad packets.
RxBroadcastPkts (32 bit)	The number of good packets received by a port that are directed to the broadcast address. This counter does not include errored broadcast packets or valid multicast packets.
RxMulticastPkts (32 bit)	The number of good packets received by a port that are directed to a multicast address. This counter does not include errored multicast packets or valid broadcast packets.
RxSACHanges (32 bit)	The number of times the SA of good receive packets has changed from the previous value. A count greater than 1 generally indicates the port is connected to a repeater based network.

**Table 28: Receive Only Counters (17) (Cont.)**

<b>Counters</b>	<b>Description</b>
RxUndersizePkts (32 bit)	The number of good packets received by a port that are less than 64 bytes long (excluding framing bits but including the FCS).
RxOversizePkts (32 bit)	The number of good packets received by a port that are greater than MAX_RX_LIMIT (excluding framing bits but including the FCS). This counter alone is incremented for packets in the range MAX_RX_LIMIT–2048 bytes inclusive, whereas both this counter and the RxExcessSizeDisc counter is incremented for packets of 2049 bytes and higher. (Revision B silicon.) See Bit 2:1 at <a href="#">Table 51: “New Control Register (Page 00h: Address 03h),” on page 157.</a> The number of good packets received by a port that are greater than 1518 (excluding framing bits but including the FCS). This counter alone is incremented for packets in the range 1518–2048 bytes inclusive, whereas both this counter and the RxExcessSizeDisc counter is incremented for packets of 2049 bytes and higher. (Revision A silicon)
RxFragments (32 bit)	The number of packets received by a port that are less than 64 bytes (excluding framing bits) and have either an FCS error or an alignment error.
RxJabbers (32 bit)	The number of packets received by a port that are longer than MAX_RX_LIMIT bytes and have either an FCS error or an alignment error (Revision B silicon). See Bit 2:1 at <a href="#">Table 51: “New Control Register (Page 00h: Address 03h),” on page 157.</a> The number of packets received by a port that are longer than 1522 bytes and have either an FCS error or an alignment error (Revision A silicon).
RxUnicastPkts (32 bit)	The number of good packets received by a port that are addressed to a unicast address.
RxAlignmentErrors (32 bit)	The number of packets received by a port that have a length (excluding framing bits but including FCS) between 64 and 1522 bytes, inclusive, and have a bad FCS with a nonintegral number of bytes.
RxFCSErrors (32 bit)	The number of packets received by a port that have a length (excluding framing bits but including FCS) between 64 and 1522 bytes inclusive, and have a bad FCS with an integral number of bytes.
RxGoodOctets (64 bit)	The total number of bytes in all good packets received by a port (excluding framing bits, but including FCS).
RxExcessSizeDisc (32 bit)	The number of good packets received by a port that are greater than 2048 bytes (excluding framing bits but including the FCS) and were discarded due to excessive length.
RxPausePkts (32 bit)	The number of PAUSE frames received by a port. The PAUSE frame must have a valid MAC Control Frame EtherType field (88-08h), have a destination MAC address of either the MAC Control frame reserved multicast address (01-80-C2-00-00-01) or the unique MAC address associated with the specific port, a valid PAUSE Opcode (00-01), be a minimum of 64 bytes in length (excluding preamble but including FCS), and have a valid CRC. Although an 802.3-compliant MAC is only permitted to transmit PAUSE frames when in full duplex mode, with flow control enabled, and with the transfer of PAUSE frames determined by the result of auto-negotiation, an 802.3-MAC receiver is required to count all received PAUSE frames, regardless of its half/full-duplex status. An indication that a MAC is in half-duplex with the RxPausePkts incrementing indicates a noncompliant transmitting device on the network.

**Table 28: Receive Only Counters (17) (Cont.)**

<b>Counters</b>	<b>Description</b>
RxSymbolErrors (32 bit)	The total number of times a valid length packet was received at a port and at least one invalid data symbol was detected. Counter only increment once per carrier event and does not increment on detection of collision during the carrier event.
RxDiscPkts (32 bit)	<p>The number of good packets received by a port that are discarded by the forwarding processes. This counter increments each time a good packet received by a port is discarded due to a final egress forwarding decision produced by the following processes:</p> <ul style="list-style-type: none"> <li>• ARL DA</li> <li>• VLAN</li> <li>• Spanning tree</li> <li>• EAP</li> <li>• CFP</li> <li>• Protected port</li> <li>• WAN port</li> <li>• VPN port</li> <li>• Link down status</li> <li>• Rate control</li> <li>• Flow control</li> </ul> <p>This counter does not include packets dropped due to Rx-based flow control process.</p>

**Table 29: Transmit Counters Only (21)**

<b>Counters</b>	<b>Description</b>
TxDropPkts (32 bit)	This counter is incremented every time a transmit packet is dropped due to lack of resources (e.g., transmit FIFO underflow), or an internal MAC sublayer transmit error not counted by either the TxLateCollision or the TxExcessiveCollision counters.
TxOctets (64 bit)	The total number of good bytes of data transmitted by a port (excluding preamble but including FCS).
TxBroadcastPkts (32 bit)	The number of good packets transmitted by a port that are directed to a broadcast address. This counter does not include errored broadcast packets or valid multicast packets.
TxMulticastPkts (32 bit)	The number of good packets transmitted by a port that are directed to a multicast address. This counter does not include errored multicast packets or valid broadcast packets.
TxCollisions (32 bit)	The number of collisions experienced by a port during packet transmissions.
TxUnicastPkts (32 bit)	The number of good packets transmitted by a port that are addressed to a unicast address.
TxSingleCollision (32 bit)	The number of packets successfully transmitted by a port that experienced exactly one collision.
TxMultipleCollision (32 bit)	The number of packets successfully transmitted by a port that experienced more than one collision.



**Table 29: Transmit Counters Only (21) (Cont.)**

<b>Counters</b>	<b>Description</b>
TxDeferredTransmit (32 bit)	The number of packets transmitted by a port for which the first transmission attempt is delayed because the medium is busy.
TxLateCollision (32 bit)	The number of times that a collision is detected later than 512 bit-times into the transmission of a packet.
TxExcessiveCollision (32 bit)	The number of packets that are not transmitted from a port because the packet experienced 16 transmission attempts.
TxPausePkts (32 bit)	The number of PAUSE frames transmitted by a port. The MAC resolve to full duplex mode, with 802.3x flow control PAUSE frame exchange enabled at the completion of auto-negotiation.
TxFramelnDisc (32 bit)	The number of valid packets received which are discarded by the forwarding process due to lack of space on an output queue. Not maintained or reported in the MIB counters. Located in the Congestion Management registers (Page 0Ah). This attribute only increments if a network device is not acting in compliance with a flow control request, or the BCM53242M internal flow control/buffering scheme has been misconfigured.
TxQoS0Pkts (32 bit)	The total number of good packets transmitted on queue 0 when QoS is enabled.
TxQoS0Octets (64 bit)	The total number of good bytes transmitted on queue 0 when QoS is enabled.
TxQoS1Pkts (32 bit)	The total number of good packets transmitted on queue 1 when QoS is enabled.
TxQoS1Octets (64 bit)	The total number of good bytes transmitted on queue 1 when QoS is enabled.
TxQoS2Pkts (32 bit)	The total number of good packets transmitted on queue 2 when QoS is enabled.
TxQoS2Octets (64 bit)	The total number of good bytes transmitted on queue 2 when QoS is enabled.
TxQoS3Pkts (32 bit)	The total number of good packets transmitted on queue 3 when QoS is enabled.
TxQoS3Octets (64 bit)	The total number of good bytes transmitted on queue 3 when QoS is enabled.

**Table 30: Transmit or Receive Counters (6)**

<b>Counters</b>	<b>Description</b>
Pkts64Octets (32 bit)	The number of packets (including error packets) that are 64 bytes long.
Pkts65to127Octets (32 bit)	The number of packets (including error packets) that are between 65 and 127 bytes long.
Pkts128to255Octets (32 bit)	The number of packets (including error packets) that are between 128 and 255 bytes long.
Pkts256to511Octets (32 bit)	The number of packets (including error packets) that are between 256 and 511 bytes long.
Pkts512to1023Octets (32 bit)	The number of packets (including error packets) that are between 512 and 1023 bytes long.
Pkts1024toMaxOctets (32 bit) (Revision B silicon)	The number of packets (including error packets) that are between 1024 and MAX_RX_LIMIT bytes long. See Bit 2:1 at <a href="#">Table 51: "New Control Register (Page 00h: Address 03h),"</a> on page 157.
Pkts1024to1522Octets (32 bit) (Revision A silicon)	The number of packets (including error packets) that are between 1024 and 1522 bytes long.

## Total Number of Counters Per Port: 35

Table 31 identifies the mapping of the BCM53242M MIB counters and their generic mnemonics, to the specific counters and mnemonics for each of the key IETF MIBs which are supported (this is defined where there is a direct mapping). However, there are several additional statistics counters that are indirectly supported, which make up the full complement of the counters required to fully support each MIB. These are shown in Table 32 on page 100. Finally, Table 33 on page 100 identifies the additional counters supported by the BCM53242M, and references the specific standard or reason for the inclusion of the counter.

**Table 31: Directly Supported MIB Counters**

<b>BCM53242M MIB</b>	<b>Ethernet-Like MIB RFC 1643</b>	<b>Bridge MIB RFC 1493</b>	<b>MIB II Interface RFC 1213/1573</b>	<b>RMON MIB RFC 1757</b>
RxDropPkts	dot3StatsInternalMAC ReceiveErrors	dot1dTpPortInDiscards	ifInDiscards	–
RxOctets	–	–	ifInOctets	etherStatsOctets
RxBroadcastPkts	–	–	ifInBroadcastPkts	etherStatsBroadcastPkts
RxMulticastPkts	–	–	ifInMulticastPkts	etherStatsMulticastPkts
RxSChanges	Note 2	Note 2	Note 2	Note 2
RxUndersizePkts	–	–	–	etherStatsUndersizePkts
RxOversizePkts	dot3StatsFrameToo Longs	–	–	etherStatsOversizePkts
RxFragments	–	–	–	etherStatsFragments
RxJabbers	–	–	–	etherStatsJabbers
RxUnicastPkts	–	–	ifInUcastPkts	–
RxAlignmentErrors	dot3StatsAlignmentErrors	–	–	–
RxFCSErrors	dot3StatsFCSErrors	–	–	–
RxGoodOctets	–	–	–	–
RxExcessSizeDisc	Note 2	Note 2	Note 2	Note 2
RxPausePkts	Note 2	Note 2	Note 2	Note 2
RxSymbolErrors	Note 2	Note 2	Note 2	Note 2
Note 1	–	–	ifInErrors	–
Note 1	–	–	ifInUnknownProtos	–
Note 1	–	dot1dTpPortInFrames	–	–
TxDropPkts	dot3StatsInternalMAC TransmitErrors	–	ifOutDiscards	–
TxOctets	–	–	ifOutOctets Note 3	–
Note 1	–	dot1dTpPortOutFrames	–	–
TxBroadcastPkts	–	–	ifOutBroadcastPkts	–
TxMulticastPkts	–	–	ifOutMulticastPkts	–
TxCollisions	–	–	–	etherStatsCollisions
TxUnicastPkts	–	–	ifOutUcastPkts	–
TxSingleCollision	dot3StatsSingleCollision Frames	–	–	–
TxMultipleCollision	dot3StatsMultipleCollision Frames	–	–	–

**Table 31: Directly Supported MIB Counters (Cont.)**

<b>BCM53242M MIB</b>	<b>Ethernet-Like MIB RFC 1643</b>	<b>Bridge MIB RFC 1493</b>	<b>MIB II Interface RFC 1213/1573</b>	<b>RMON MIB RFC 1757</b>
TxDeferredTransmit	dot3StatsDeferred Transmissions	–	–	–
TxLateCollision	dot3StatsLateCollision	–	–	–
TxExcessiveCollision	dot3StatsExcessive Collision	–	–	–
TxFramelnDisc	Note 2	Note 2	Note 2	Note 2
TxPausePkts	Note 2	Note 2	Note 2	Note 2
Note 4	dot3StatsCarrierSense Errors	–	–	–
Note 1	–	–	ifOutErrors	–
Pkts64Octets	–	–	–	etherStatsPkt64Octets
Pkts65to127Octets	–	–	–	etherStatsPkt65to127 Octets
Pkts128to255Octets	–	–	–	etherStatsPkt128to255 Octets
Pkts256to511Octets	–	–	–	etherStatsPkt256to511 Octets
Pkts512to1023Octets	–	–	–	etherStatsPkt512to1023 Octets
Pkts1024toMaxOctets (Revision B silicon)	–	–	–	etherStatsPkt1024toMax Octets
Pkts1024to1522Octets (Revision A silicon)	–	–	–	etherStatsPkt1024to1522 Octets
Note 1	–	–	–	etherStatsDropEvents
Note 1	–	–	–	etherStatsPkts
Note 1	–	–	–	etherStatsCRCAAlignErrors
Note 4	dot3StatsSQETestErrors	–	–	–

Note 1: Derived by summing two or more of the supported counters. See [Table 32 on page 100](#) for specific details.

Note 2: Extensions required by recent Standards developments or BCM53242M operation specifics.

Note 3: The MIB II Interfaces specification for if OutOctets includes preamble/SFD and errored bytes. Because 802.3 compliant MACs have no requirement to keep track of the number of transmit bytes in an errored frame, this count is impossible to maintain. The TxOctets maintained by the BCM53242M is consistent with good bytes transmitted, excluding preamble but including FCS. The count can be adjusted to more closely match the if OutOctets definition by adding the preamble for TxGoodPkts, and possibly an estimate of the octets involved in TxCollisions and TxLateCollision.

Note 4: The attributes TxCarrierSenseErrors and TxSQETestErrors are not supported in the BCM53242M. These attributes were originally defined to support coax based AUJ transceivers. The BCM53242M's integrated transceiver design means these error conditions are eliminated. MIBs intending to support such counters should return a value of 0 or not supported.

**Table 32: Indirectly Supported MIB Counters**

<b>BCM53242M MIB</b>	<b>Ethernet-Like MIB RFC 1643</b>	<b>Bridge MIB RFC 1493</b>	<b>MIB II Interface RFC 1213/1573</b>	<b>RMON MIB RFC 1757</b>
RxErrorPkts = RxAlignmentErrors + RxFCSerrors + RxFragments + RxOversizePkts + RxJabbers	–	–	ifInErrors	–
–	–	–	ifInUnknownProtos	–
RxGoodPkts = RxUnicastPkts + RxMulticastPkts + RxBroadcastPkts	–	dot1dTpPortIn Frames	–	–
DropEvents = RxDropPkts + TxDropPkts	–	–	–	etherStatsDrop Events
RxTotalPkts = RxGoodPkts + RxErrorPkts	–	–	–	etherStatsPkts
RxCRCAlignErrors = RxCRCerrors + RxAlignmentErrors	–	–	–	etherStatsCRCAlign Errors
NA—BCM53242M cannot experience this error—return as 0	dot3StatsSQETest Errors	–	–	–
RxFramesTooLong = RxOversizePkts + RxJabber	dot3StatsFrameToo Longs	–	–	–
TxGoodPkts = TxUnicastPkts + TxMulticastPkts + TxBroadcastPkts	–	dot1dTpPortOut Frames	–	–
TxErrorPkts = TxExcessiveCollision + TxLateCollision Note 1	–	–	ifOutErrors	–

Note 1: The number of packets transmitted from a port which experienced late collision, or excessive collision. While for some media types in half-duplex operation, frames which experience carrier sense errors are also summed in this counter, the BCM53242M's integrated design means this error condition is eliminated.

**Table 33: Supported MIB Extensions**

<b>MIB</b>	<b>Appropriate Standards Reference</b>
RxSACchanges	IEEE 802.3u Clause 30—Repeater Port Managed Object Class, aSourceAddressChanges

**Table 33: Supported MIB Extensions (Cont.)**

<b>MIB</b>	<b>Appropriate Standards Reference</b>
RxExcessSizeDisc	The BCM53242M cannot store packets in excess of 1536 bytes (excluding preamble/SFD but inclusive of FCS). This counter indicates packets that were discarded by the BCM53242M due to excessive length.
RxPausePkts	IEEE 802.3x Clause 30—Pause Entity Managed Object Class, PAUSEMACCtrlFramesReceived
RxSymbolErrors	IEEE 802.3u Clause 30—Repeater Port Managed Object Class, aSymbolErrorDuringPacket
TxFramesInDisc	Internal diagnostic use for optimization of flow control and buffer allocation algorithm.
TxPausePkts	IEEE 802.3x Clause 30—Pause Entity Managed Object Class, aPAUSEMACCtrlFramesTransmitted

Broadcom Confidential

## Section 4: System Interfaces

---

### Overview

The BCM53242M includes the following interfaces.

Each of these is discussed in more detail in the following sections.

- [“MII Port” on page 102](#)
- [“GMII/RGMII/TBI Port” on page 104](#)
- [“10/100 Mbps Copper Interface” on page 105](#)
- [“Configuration Pins” on page 106](#)
- [“Programming Interfaces” on page 107](#)
- [“EEPROM Interface” on page 112](#)
- [“MDC/MDIO Interface” on page 114](#)
- [“LED Interfaces” on page 123](#)
- [“JTAG Interface” on page 130](#)
- [“Internal Voltage Regulators” on page 130](#)

---

### MII Port

The BCM53242M provides a fully 802.3u compatible MII interface as a twenty-fifth network port (port 48). The port can be configured to operate differently dependent on the programming of the internal registers.

### Network Port

In unmanaged mode after power-up, the MII operates as a normal MAC-based MII port, capable of interfacing directly to an external TX or FX transceiver. The port incorporates an internal MAC, and functions identically to the integrated 10/100 ports. Frames are forwarded to the port under control of the forwarding model.

Predecessors of the BCM53242M device allowed the MII management signals (MDC/MDIO) to interrogate the internal MII registers associated with the integrated 10/100 Mbps PHYs. The BCM53242M can still support this mode, in which case, configuration of the integrated PHYs requires the 2.5-MHz clock to be supplied to the BCM53242M MDC pin and any external MII-connected transceiver, and the external management device controls MDIO to select and configure all the PHYs appropriately. To operate in this mode, the external transceiver needs to support some signals in addition to the standard MII signals, so that the state of the external transceiver can be monitored by the BCM53242M. Individual active-low Link, Speed (100 Mbps), Duplex, and link partner Flow Control mode signals from the transceiver should be provided. An MII-based single 10/100 Mbps PHY, such as the BCM5202, provides these additional signals. With these additional signals, the BCM53242M generates port LEDs for the external MII-based PHY, equivalent to the LEDs of the internal transceivers.

The more typical use of the MII in a BCM53242M implementation is that the device is accessed via the SPI. In this case, on sensing activity of the SPI, the BCM53242M takes control of the MII management pins, and sources the 2.5-MHz clock signal for MDC. The external PHY can be accessed by the management entity, since its MII registers are aliased to the Port 48. Access to MII registers in this page in the register map automatically generates an MDIO/MDC request to the external MII-based transceiver, allowing configuration control and status monitoring of the off-chip PHY port. The MII port uses the unique PHY address of 18h. The external PHY must be programmed/strapped to respond to the PHY address of 18h. See [“MDC/MDIO Interface” on page 114](#) for additional detail on internal and external PHY address values.

When an external transceiver is connected to the BCM53242M MII port and managed by the MDC/MDIO lines, the state of the link, speed, full/half-duplex and link partner flow control capabilities (among many others) can all be accessed via software, and need not be provided as hardware pins. In order to preserve LED display capabilities for the MII port, an additional alias register is provided in the Control registers (Page 0h). All the specific register information is temporary and subject to be change in the final version of the data sheet. This allows the state of the aforementioned status bits to be read from the external PHY and then written to this register, so that consistent LED status information for all 10/100 ports can be preserved.

If no MII-based external transceiver is present, page 28h of the register space is not present, and returns indeterminate data when read.

## Reverse MII Port

BCM53242M device includes an enhanced MII mode that supports direct MAC-to-MAC connectivity. The BCM53242M device supports a strap option selectable Reverse MII (RvMII) mode, which makes the BCM53242M MII interface appear as a 100-Mbps full-duplex PHY MII, as seen by the external MAC.

To support this RvMII mode, the clock-to-data timing has been modified. The TXC/RXC input clocks become 25-MHz clock outputs (identical to those of a PHY MII) that only support a 100-Mbps MII interface.

Rv MII mode is enabled by selecting the strap pin RvMII.

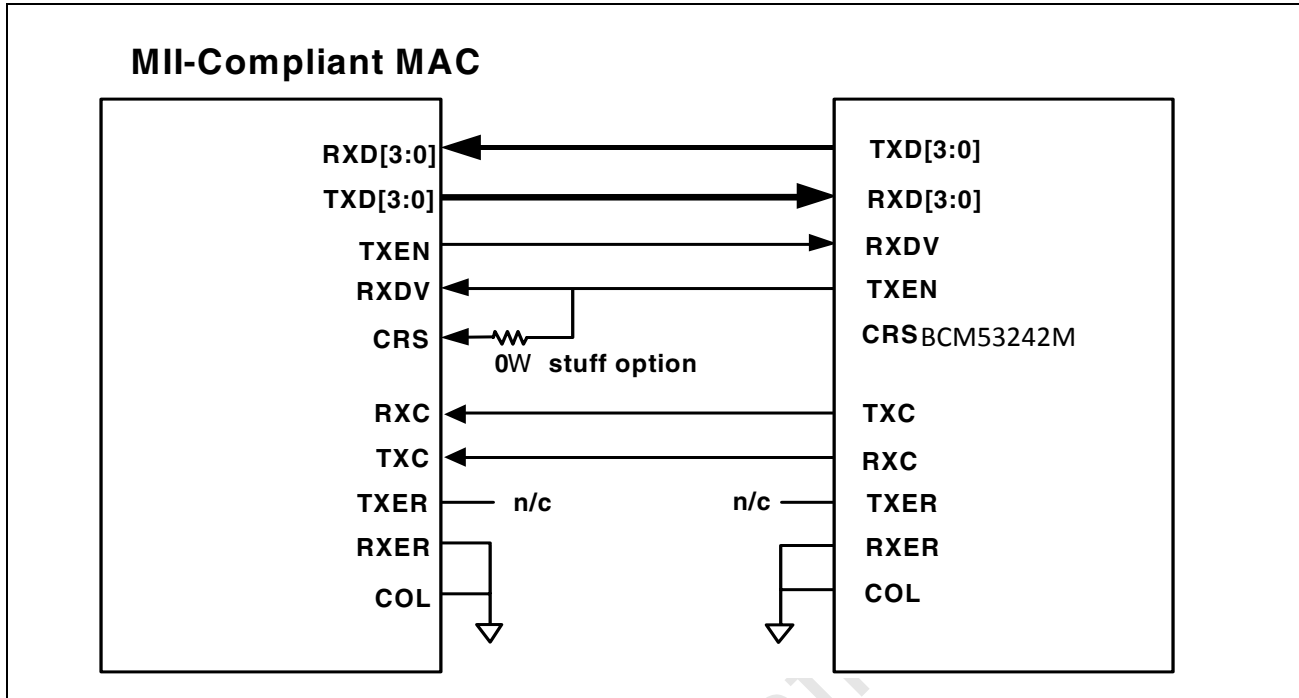

Figure 19: MAC-to-MAC MII Connection

## Management Port (IMP)

The dedicated port can be used as a high-speed connection to transfer management packets to the external management agent. For more information, see [“Frame Management” on page 88](#)

## GMII/RGMII/TBI Port

### GMII

The Gigabit Media Independent Interface (GMII) is a MAC interface allowing the BCM53242M to connect to an external PHY. Transmit and receive data is clocked on the rising edge of the clocks. The GMII transmits data synchronously via the TXD[7:0] and RXD[7:0] data signals. The GTXCLK and RXC clock speeds are 125 MHz when the external PHY is operating at 1000 Mbps. The TXC and RXC clock speeds are reduced to 2.5 MHz and 25 MHz when the external PHY is linked at 10 Mbps and 100 Mbps, respectively. The external PHY status is monitored via the MDC/MDIO interface. The external GPHYs must be programmed/strapped to respond to the PHY address of 19h and 1Ah respectively.



## RGMII

The Reduced Gigabit Media Independent Interface (RGMII) is a MAC interface allowing the BCM53242M to connect to an external PHY. Transmit and receive data is clocked on both the rising and falling edge of the clocks. This reduces the number of data signals crossing the MAC interface without affecting the data transmission rate. The RGMII transmits data synchronously via the TXD[3:0] and RXD[3:0] data signals. The GTXCLK and RXC clock speeds are 125 MHz when the external PHY is operating at 1000 Mbps. These clock speeds are reduced to 2.5 MHz and 25 MHz when the external PHY is linked at 10 Mbps and 100 Mbps, respectively. The external PHY status is monitored via the MDC/MDIO interface.

## TBI

The Ten-Bit Interface (TBI) is a MAC interface allowing the BCM53242M to connect directly to the industrial standard SerDes for connecting to Gigabit Ethernet optical-fiber device. In the Ten-Bit mode, the TBI transmits the 10-bit encoded data via the TXD[9:0] signals synchronous to the GTXCLK at 125 MHz and receives data via RXD[9:0] signals synchronous to the TBI\_RBC[1:0] clocks at 62.5 MHz.

Table 34 outlines the MIIGMII/RGMII/TBI interface I/O signal map of the BCM53242M.

**Table 34: MII/GMII/RGMII/TBI Mapping**

<b>BCM53242M</b>	<b>GMII</b>	<b>RGMII</b>	<b>TBI</b>	<b>MII</b>
GMII(0:1)_TXD[3:0]	TXD[3:0]	TXD[3:0]	TXD[3:0]	TXD[3:0]
GMII(0:1)_TXD[7:4]	TXD[7:4]	–	TXD[7:4]	–
GMII(0:1)_GTXCLK	GTXCLK	GTXCLK	REFCLK	–
GMII(0:1)_TX_EN	TX_EN	TX_EN	TXD[8]	TX_EN
GMII(0:1)_TX_ER	TX_ER	–	TXD[9]	TX_ER
GMII(0:1)_COL	COL	–	–	COL
MII(0:1)_TXC	TXC	TXC	–	TXC
GMII(0:1)_RXD[3:0]	RXD[3:0]	RXD[3:0]	RXD[3:0]	RXD[3:0]
GMII(0:1)_RXD[7:4]	RXD[7:4]	–	RXD[7:4]	–
GMII(0:1)_RXCLK	RXC	RXC	–	RXC
GMII(0:1)_RXDV	RX_DV	RX_DV	RXD[8]	RX_DV
GMII(0:1)_RXER	RXER	–	RXD[9]	RXER
TBI(0:1)RBC[1:0]	–	–	RBC[1:0]	–
GMII(0:1)_CRS	CRS	–	–	CRS

## 10/100 Mbps Copper Interface

The internal PHYs transmit and receive data via the digiPHY. This section discusses the following topics:

- “Auto-Negotiation”
- “Automatic MDI Crossover”

- [“10/100Base-T Forced Mode Auto-MDIX”](#)

For more information on the integrated PHY block, see [“Integrated PHY” on page 77](#).

## Auto-Negotiation

The BCM53242M negotiates its mode of operation over the copper media using the auto-negotiation mechanism defined in the IEEE 802.3u specifications. When the auto-negotiation function is enabled, the BCM53242M automatically chooses the mode of operation by advertising its abilities and comparing them with those received from its link partner. The BCM53242M can be configured to advertise the following modes:

- 100Base-TX full-duplex and/or half-duplex
- 10Base-T full-duplex and/or half-duplex

The transceiver negotiates with its link partner and chooses the highest common operating speed and duplex mode, commonly referred to as highest common denominator (HCD).

## Automatic MDI Crossover

During auto-negotiation, one end of the link needs to perform an MDI crossover so that each transceiver's transmitter is connected to the other receiver. The BCM53242M internal PHY can perform an automatic media dependent interface (MDI) crossover, eliminating the need for crossover cables or cross-wired (MDIX) ports.

During auto-negotiation, the BCM53242M internal PHY normally transmits on the TD± pin and receives on the RD± pin. When connecting to another device that does not perform MDI crossover, the BCM53242M internal PHY automatically switches its RD±/TD± pin pairs, when necessary, to communicate with the remote device. When connecting to another device that does have MDI crossover capability, an algorithm determines which end performs the crossover function. During 100Base-TX operation, pair swaps automatically occur within the device and do not require user intervention.

## 10/100Base-T Forced Mode Auto-MDIX

The Forced Mode Auto-MDIX feature allows the copper auto-negotiation to be disabled in either 10Base-T or 100Base-T and still take advantage of the automatic MDI crossover function. Whenever the forced link is down for at least four seconds, then auto-negotiation is internally enabled with its automatic MDI crossover function until link pulses or 100Base-Tx idles are detected. Once detected, the internal PHY returns to forced mode operation.

---

## Configuration Pins

Initial configuration of the BCM53242M takes place during power-on/reset by loading internal control values from hardware strap pins. The value of the pin is loaded when the reset sequence completes and the pin transitions to normal operation. Pull-up or pull-down resistors can be added to these pins to control the device configuration. If the pins are left floating, the default value is determined based on the internal pull-up or pull-down configuration.

## Programming Interfaces

The BCM53242M can be programmed via the SPI Interface, EEPROM Interface, or Extended Bus. The SPI interface provides access for a general purpose microcontroller, allowing read and write access to the internal BCM53242M register space. It is configured to be compatible with the Motorola<sup>®</sup> Serial Peripheral Interface (SPI) protocol. Alternatively, the EEPROM interface can be connected to an external EEPROM for writing register values upon power-up initialization.

A 16-bit or 8-bit extended bus interface on the BCM53242M is designed to provide connection to an external processor, allowing read and write accesses to the internal BCM53242M registers.

The internal address space of the BCM53242M device is broken into a number of pages. Each page groups a logical set of registers associated with a specific function. Each page provides a logical address space of 256 bytes, although, in general, only a small portion of the address space in each page is utilized.

### SPI Interface

The BCM53242M can be controlled over a serial interface that is compatible with a subset of the Motorola Synchronous Serial Peripheral Interconnect (SPI) bus. The microcontroller interface consists of four signals: serial clock (SCK), slave select (SS/CS), master-in/slave-out (MISO/DO) and master-out/slave-in (MOSI/DI). The BCM53242M always operates as an SPI slave device, in that it never initiates a transfer on the SPI and only responds to the read and write requests issued from a master device.

A layer of protocol is added to the basic SPI definition to facilitate transfers from the BCM53242M. This protocol establishes the definition of the first two bytes issued by the master to the BCM53242M slave during an SPI transfer. The first byte issued from the SPI master in any transaction is defined as a command byte, which is always followed by a register address byte, and any additional bytes are data bytes.

The SPI mode supports normal SPI determined by the content of the command byte. [Table 35](#) shows the normal SPI command byte.

**Table 35: Normal SPI Command Byte**

0	1	1	MODE = 0	CHIP ID 2 (MSB)	CHIP ID 1	CHIP ID 0 (LSB)	Read/ Write (0/1)
---	---	---	----------	--------------------	-----------	--------------------	-------------------------

The MODE bit (bit 4) of the command byte determines the meaning of bits 7:5. If bit 4 is a 0, it is a normal SPI command byte, and bits 7:5 should be defined as 011b.

In command bytes, bits[3:1] indicate the CHIP ID to be accessed. Because the BCM53242M operates as a single-chip system, the CHIP ID will be 000. Note that the SS# signal must also be active for any BCM53242M device to recognize that it is being accessed.

Bit 0 of the command byte is the R/W signal (0 = Read, 1 = Write) and determines the transmission direction of the data.

The byte following the command byte is an 8-bit register address. Initially, this sets the page address, followed by another command byte that contains the register base address in that page, which is used as the location to store the next byte of data received in the case of a write operation, or the next address from which to retrieve data in the case of a read operation. This base address increments as each byte of data is transmitted/received, allowing a contiguous block data from a register to be stored/read in a single transmission.

Noncontiguous blocks are also stored/read through the use of multiple transmissions, which allow a new command byte and register base address to be specified. The SS signal must remain low for the entire read or write transaction, as shown in [Figure 20 on page 108](#) and [Figure 21 on page 108](#), with the transaction terminated by the deassertion of the SS line by the master.

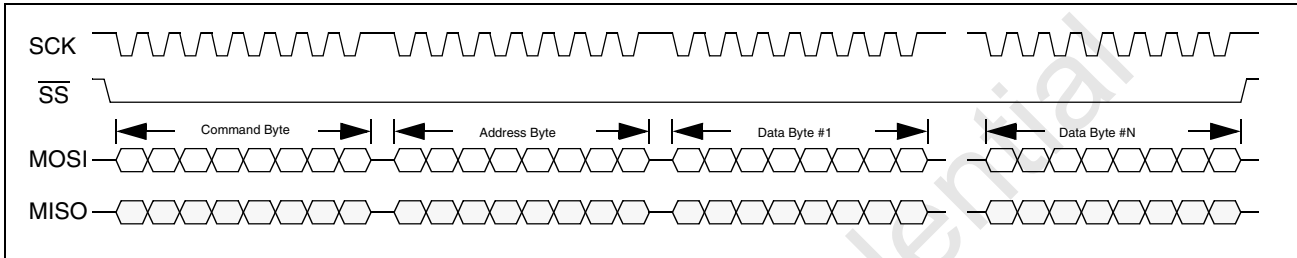

**Figure 20: SPI Serial Interface Write Operation**

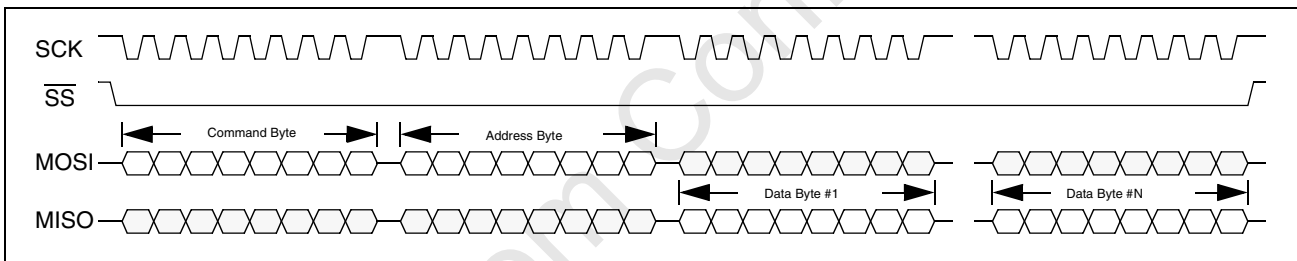

**Figure 21: SPI Serial Interface Read Operation**

The Serial Interface supports operation up to 2 MHz in SPI mode.

### Normal SPI Mode

Normal SPI mode allows single-byte read and multibyte string write operations, with the CPU polling to monitor progress. Read operations are performed using the SPI Status Register and SPI Data I/O Register. All read operations take the form:

<CMD, CHIP ID, R><REG ADDR>

where the first byte is the command byte with the appropriate CHIP ID and Read bits set, and the second byte is the register address.

All write operations are of the form:

<CMD, CHIP ID, W><REG ADDR><DATA0>...<DATAn>

where the first byte is the command byte with the appropriate CHIP ID and Write bits set, the second byte is the register address, and the remaining bytes are the exact number of data bytes appropriate for the selected register follow. Failure to provide the correct number of data bytes means the register write operation does not occur.

A simple flow chart for the read process is shown in [Figure 22 on page 110](#).

To read a register, first the Page Register is written (<CMD, CHIP ID, W><REG ADDR = FFh><DATA = NEW PAGE>). It is only necessary to write the page register when moving to a new page. Once in the correct page, a read operation is performed on the appropriate register (<CMD, CHIP ID, R><REG ADDR>). Once the SPI Status Register indicates that the data is available (RACK = 1), the data can be read. Data is read from the SPI Data I/O Register, located at F0h–F7h on every page (so no page swap is necessary to read the data on any page). A read operation can access any or all of the bytes on a specific register, including the ability to start at any offset. For instance, reading from SPI Data I/O Register [0], reads the least significant byte of the register, and successive reads to SPI Data I/O Register [0] read the remaining bytes. However, reading the first byte from SPI Data I/O Register [2] reads the third byte of the register, and successive reads to SPI Data I/O Register [2] reads the remaining bytes of the register up to the most significant byte of the register. It is not necessary to read all bytes of a registers, only the bytes of interest. The SPI master can then move on to perform another read or write operation.

A flow chart for the write process is shown in [Figure 23 on page 111](#). To write a register, the Page Register is written if necessary (<CMD, CHIP ID, W><REG ADDR = FFh><DATA = NEW PAGE>), then data is written to the selected register (<CMD, CHIP ID, W><REG ADDR><DATA0>...<DATAn>), where DATA0 is the least significant byte of the register, and DATAn is the most significant byte of the register, and the exact number of bytes is present as defined by the register width. No byte offset is provided for write operations, and all bytes must be present to activate the write process internal to the BCM53242M.

The following simple rules apply to the normal SPI mode:

- A write to the page register at any time causes the SPI state machine to reset.
- A read operation can access any number of bytes at any offset using the SPI Data I/O Register.
- A write operation must write the exact number of bytes to the register being accessed.
- The RXRDY/TXRDY flags in SPI Status Register must be checked after each 8-byte string has been read/written to ensure the next string is ready and can be accepted (since the largest internal register is 8 bytes, this restriction only applies to reading and writing frames via the SPI).

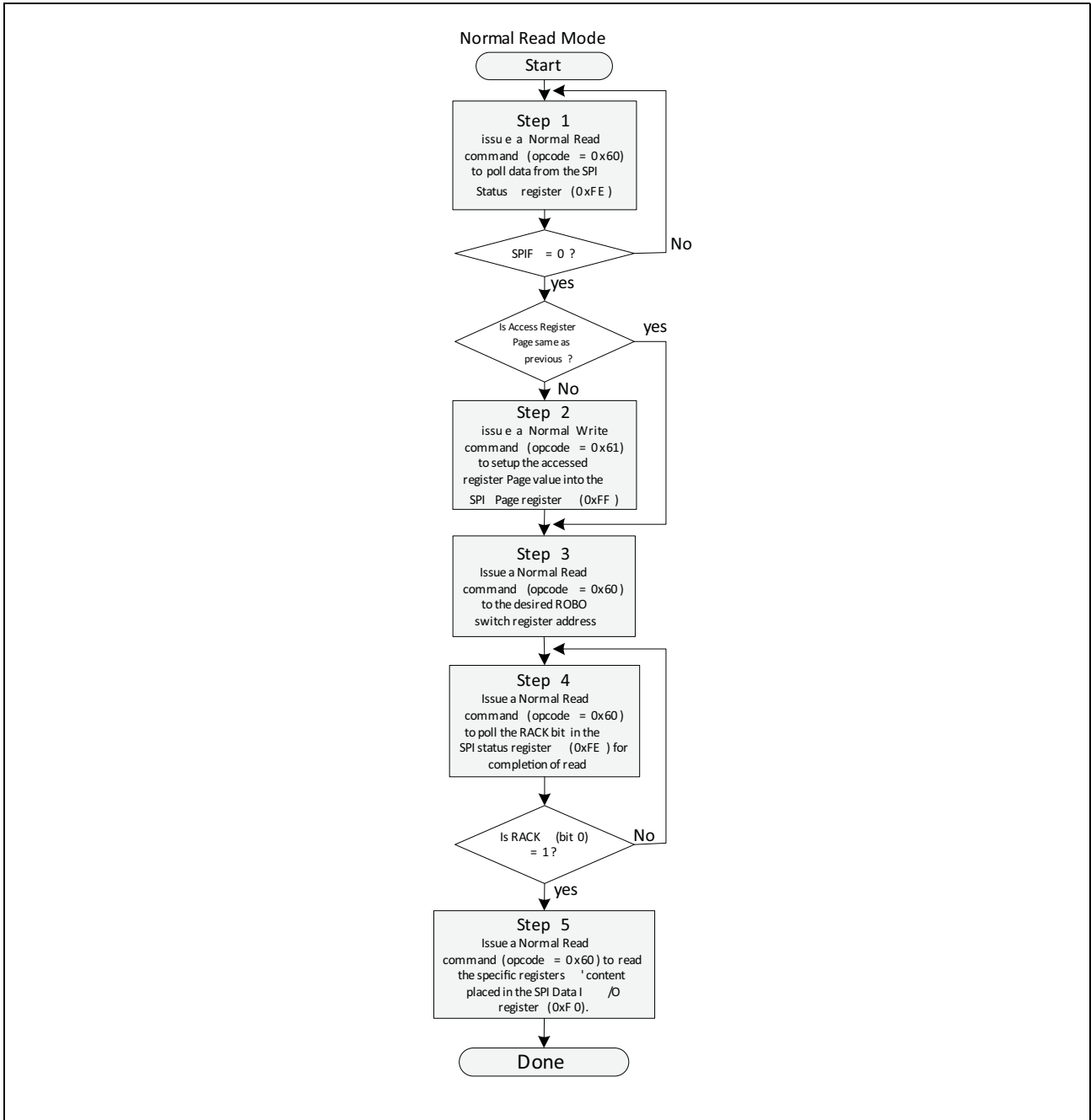

Figure 22: Normal SPI Mode Read Flow Chrt

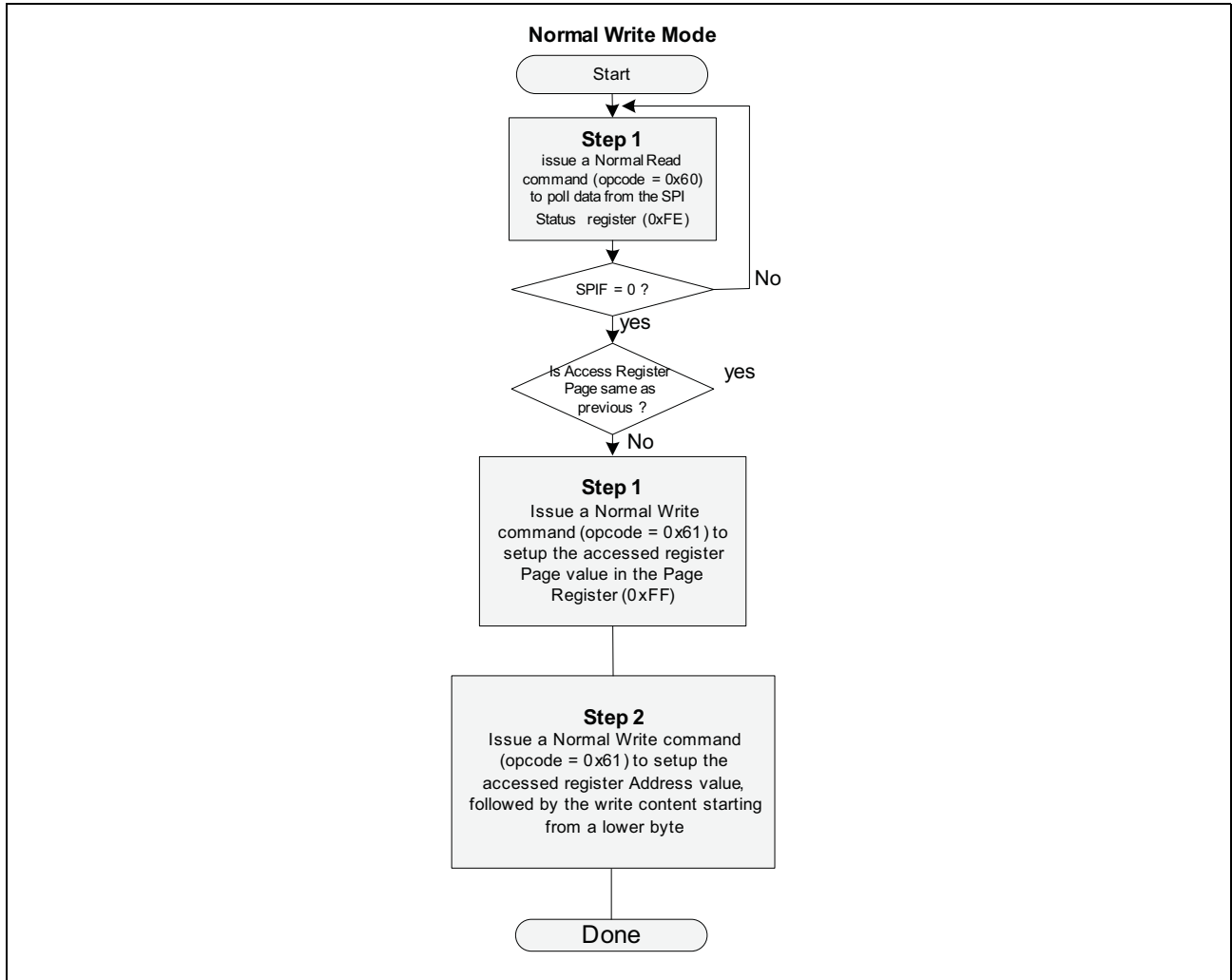
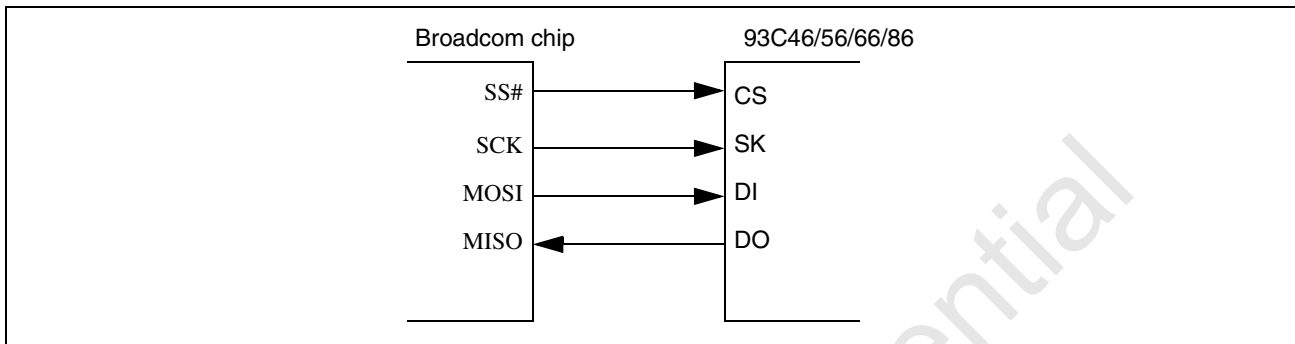

Figure 23: Normal SPI Mode Write Flow Chart

## EEPROM Interface

The BCM53242M can be connected via the Serial Interface to a low-cost external serial EEPROM, enabling it to download register programming instructions during power-on initialization. For each programming instruction fetched from the EEPROM, the instruction executes immediately and affects the register file.



**Figure 24: Serial EEPROM Connection**

During the chip initialization phase, the data is sequentially read-in from the EEPROM after the internal memory has been cleared. The first data read-in is the HEADER and matches a predefined magic code. In the case where the HEADER data does not match the instruction fetch, the process stops, and the EEPROM controller treats it as if no EEPROM exists. If the magic code matches, the fetch instruction process continues until it reaches the instruction length defined in the HEADER.

The BCM53242M supports EEPROMs with varying capacities. These include the 93C46, 93C56, 93C66 and 93C86. The BCM53242M implements the automatic detection of EEPROM types. The two EEPROM\_TYPE[1:0] strap pins are designated as “don't cares” and “can be ignored”.

### EEPROM Format

The EEPROM should be configured to x16 word format. The header contains a key and length information as in [Table 36](#).

- Upper 5 bits are magic code 15h, which indicates valid data follows.
- Bit 10 is for speed indication. A 0 means normal speed. A 1 indicates speed up. The default is 0.
- Lower 10 bits indicate the total length of all entries. For example:
  - 93C46 up to 64 words
  - 93C56 up to 128 words
  - 93C66 up to 256 words
  - 93C86 up to 1024 words



**Table 36: EEPROM Header Format**

<b>15:11</b>	<b>10</b>	<b>9:0</b>
Magic code, 15h	Speed	Total Entry Number <ul style="list-style-type: none"> <li>• 93C46: 0–63</li> <li>• 93C56: 0–127</li> <li>• 93C66: 0–255</li> <li>• 93C86: 0–1023</li> </ul>

After chip initialization, the header is read from the EEPROM and used to compare to the pre-defined magic code. When the fetched data does not match the predefined magic code, the EEPROM instruction fetch process is stopped. If the magic code is matched, fetching instructions continues until the instruction length as defined in the HEADER.

The EEPROM Port shares pins with the SPI port. Either the SPI port or the EEPROM can be selected by using the strap pin, CPU\_EEPROM\_SEL. The register space for the EEPROM port is the same as for the SPI port.

Contact your local Broadcom FAE for EEPROM Programming Guide for more details on EEPROM data format.

---

## MDC/MDIO Interface

### MDC/MDIO Master Interface

Each of the external transceivers can be daisy-chained to the MDC and MDIO pins of the BCM53242M. The BCM53242M uses the MDC/MDIO interface to read/write the register information of the external transceivers.

The BCM53242M initiates a master MII access cycle when:

- Automatically polling the external PHY MII registers, unless the PHY\_POLL\_DIS strap pin is deliberately pulled high
- Any SCK activity is detected on the SPI interface to access the external PHY MII registers

Each external transceiver is assigned a unique hardware PHY address for MII management. The IMP port hardware PHY address is 18h. Gigabit ports G0 and G1 have hardware PHY addresses 19h and 1Ah respectively.

Each time a master MII write or read operation is executed, the transceiver compares the PHY address with its own PHY address definition. The operation is executed only when the addresses match.



**Note:** When a master MII access cycle is executed, the BCM53242M sources a 2.5 MHz clock on the MDC pin.

### MDC/MDIO Slave Interface

The BCM53242M executes a MII slave access cycle, when the CPU initiates a read/write access to either the switch registers or the internal transceiver MII registers.

### Switch Register Access Through Pseudo-PHY Interface

The switch registers are organized into pages, each of which contains a defined register set. To access any switch register, both the page number and register address must be specified.

The CPU can access the BCM53242M switch registers through the MDC and MDIO interface. The switch registers are accessed through a pseudo-PHY (PHY Address = 01E), which is not used by any of the physical transceivers on the BCM53242M MDC/MDIO path. Page number, register address and the read/write data are encapsulated in the MII management frame format.

The algorithm for read access to the switch registers is shown in [Figure 33 on page 121](#). The algorithm for write access is shown in [Figure 34 on page 122](#). The pseudo-PHY MDC/MDIO interface has an address space of 32, as shown in [Figure 26 on page 118](#). The first 16 registers are reserved by IEEE. Only addresses 16-31 can be used to access the switch registers. The switch register page number, register address, and access type are determined by registers 16 and 17. The data read from or written to a switch register is stored in registers 24 to 27 (64 bits total).

## MDC/MDIO Slave Interface Register Programming

Each internal transceiver in the BCM53242M is assigned a unique hardware PHY address.

Transceiver 0 has address 00000. Transceivers 1-23 have addresses 1 through 17h, respectively.

Each internal PHY checks that the PHY address of the initiated command matches that of its own before executing the command.

The BCM53242M fully complies with the IEEE 802.3u Media Independent Interface (MII) specification. The MII management interface registers of each internal transceiver are serially written-to and read-from using a common set of MDIO and MDC pins. A single clock must be provided to the BCM53242M at a rate of 0-12.5 MHz through the MDC pin.

The serial data is communicated on the MDIO pin. Every MDIO bit must have the same period as the MDC clock. The MDIO bits are latched on the rising edge of the MDC clock. MDC may be stopped between frames provided no timing requirements are violated. MDC must be active during each valid bit of every frame, including preamble, instruction, address, data, and at least one idle bit. Every MII read or write instruction frame contains the fields shown in [Table 37](#).

**Table 37: MII Management Frame Format**

<i>Operation</i>	<i>PRE</i>	<i>ST</i>	<i>OP</i>	<i>PHYAD</i>	<i>REGAD</i>	<i>TA</i>	<i>DATA</i>	<i>IDle</i>	<i>Direction</i>
Read	1 ... 1	01	10	AAAAA	RRRRR	ZZ Z0	Z ... Z D ... D	Z Z	Driven to BCM53242M Driven by BCM53242M
Write	1 ... 1	01	01	AAAAA	RRRRR	10	D ... D	Z	Driven to BCM53242M

### Preamble (PRE)

32 consecutive 1 bits must be sent through the MDIO pin to the BCM53242M to signal the beginning of an MII instruction. Fewer than 32 1 bits will cause the remainder of the instruction to be ignored. In preamble suppression mode, only two preamble bits are required between frames.

### Start of Frame (ST)

A 01 pattern indicates that the start of the instruction follows.

### Operation Code (OP)

A read instruction is indicated by 10, while a WRITE instruction is indicated by 01.

### PHY Address (PHYAD)

A 5-bit PHY address follows next, with the MSB transmitted first. The PHY address allows a single MDIO bus to access multiple PHY chips.

## Register Address (REGAD)

A 5-bit Register Address follows, with the MSB transmitted first. The register map of the BCM53242M, containing register addresses and bit definitions, are provided on the following pages.

## Turnaround (TA)

The next two bit times are used to avoid contention on the MDIO pin when a read operation is performed. For a Write operation, 10 must be sent to the BCM53242M chip during these two bit times. For a read operation, the MDIO pin must be placed into high-impedance during these two bit times. The chip drives the MDIO pin to 0 during the second bit time.

## Data

The last 16 bits of the frame are the actual data bits. For a write operation, these bits are sent to the BCM53242M, whereas, for a read operation, these bits are driven by the BCM53242M. In either case, the MSB is transmitted first. When writing to the BCM53242M, the data field bits must be stable during the rising edge of MDC. When reading from the BCM53242M, the data field bits are valid after the rising-edge of MDC until the next rising-edge of MDC.

## Idle

A high impedance state of the MDIO line. All tri-state drivers are disabled and an external pull-up resistor pulls the MDIO line to logic 1. At least one or more clocked idle states are required between frames.

Following are two examples of MII write and read instructions:

To put a transceiver with PHY address 00001 into Loopback mode, the following MII write instruction must be issued:

- 1111 1111 1111 1111 1111 1111 1111 1111 0101 00001 00000 10 0100 0000 0000 0000

To determine if a PHY is in the link pass state, the following MII read instruction must be issued:

- 1111 1111 1111 1111 1111 1111 1111 1111 0110 00001 00001 ZZ ZZZZ ZZZZ ZZZZ ZZZZ

For the MII read operation, the BCM53242M will drive the MDIO line during the second half of the TA field and the Data field (the last 17 bit times).

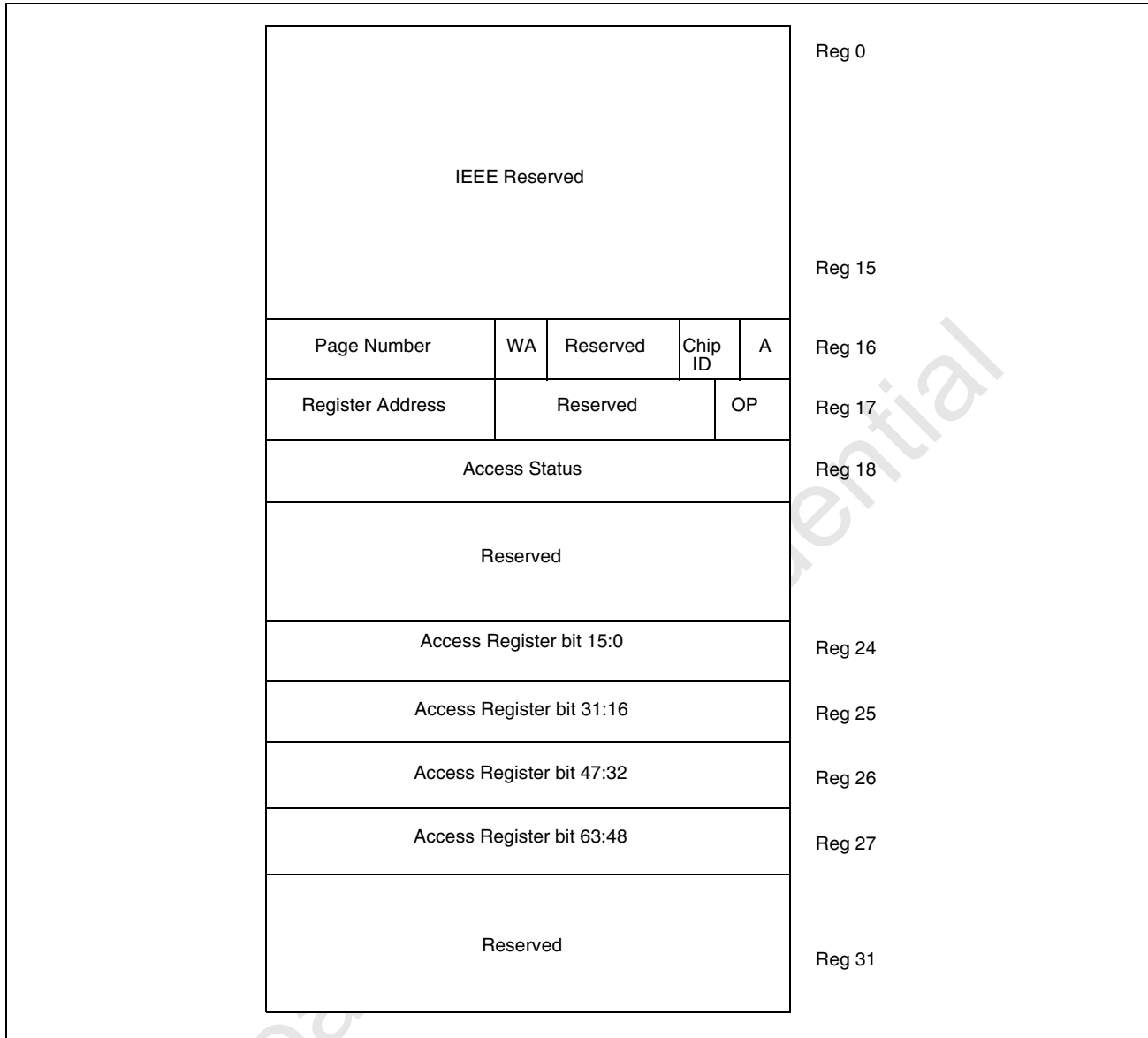
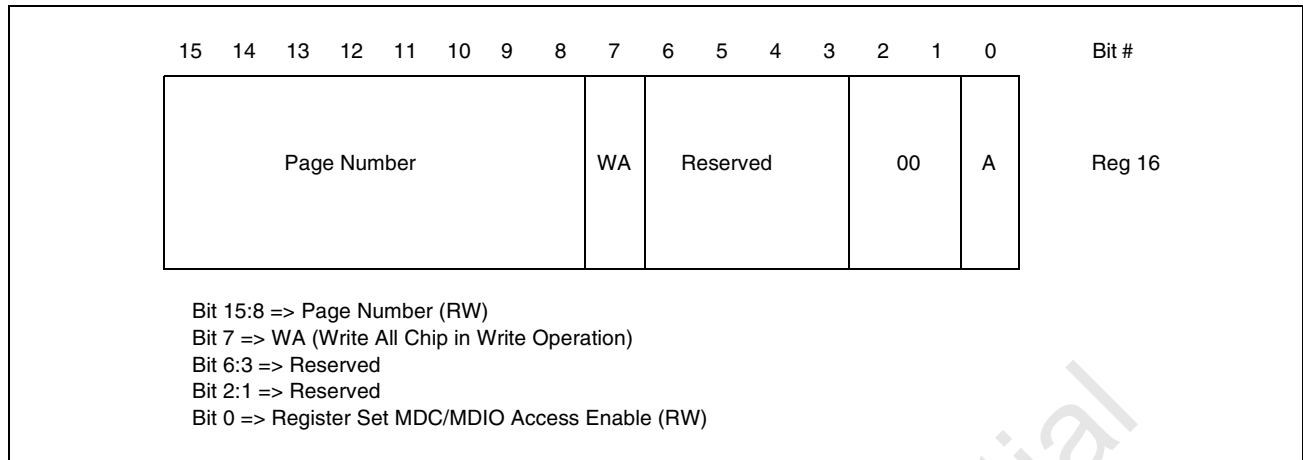
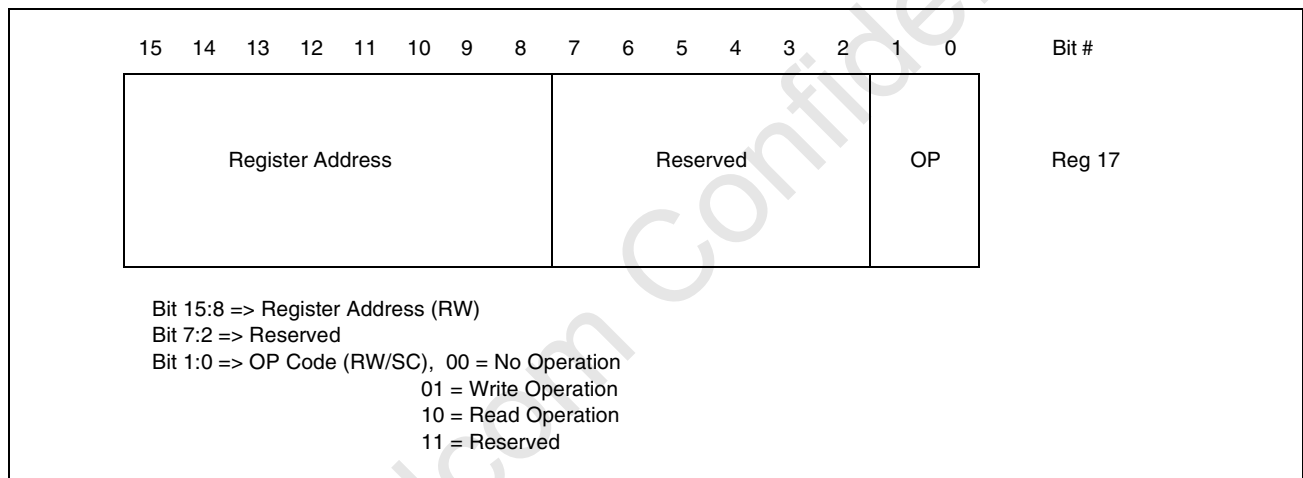

Figure 25: Pseudo PHY MII Register Definitions



**Figure 26: Pseudo PHY MII Register 16: Register Set Access Control Bit Definition**



**Figure 27: Pseudo PHY MII Register 17: Register Set Read/Write Control Bit Definition**

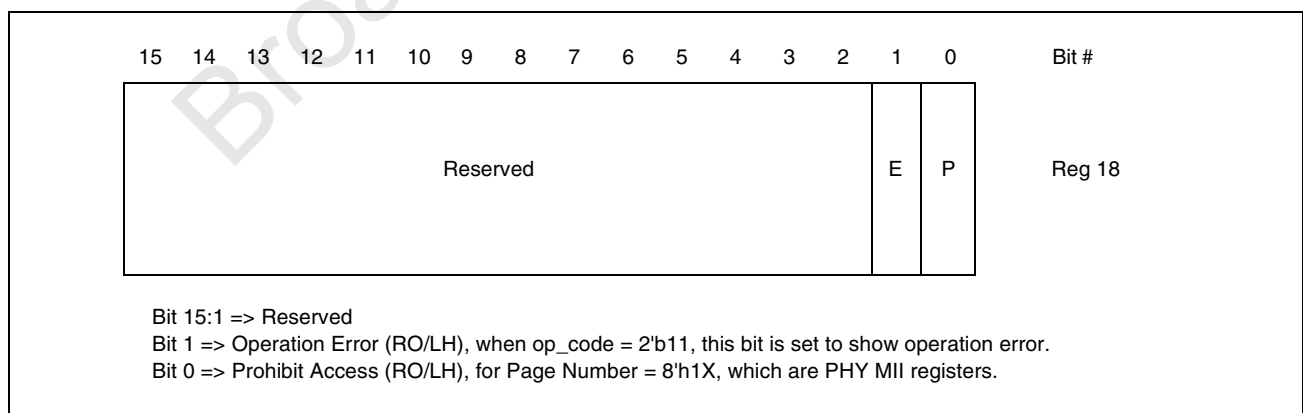

**Figure 28: Pseudo PHY MII Register 18: Register Access Status Bit Definition**

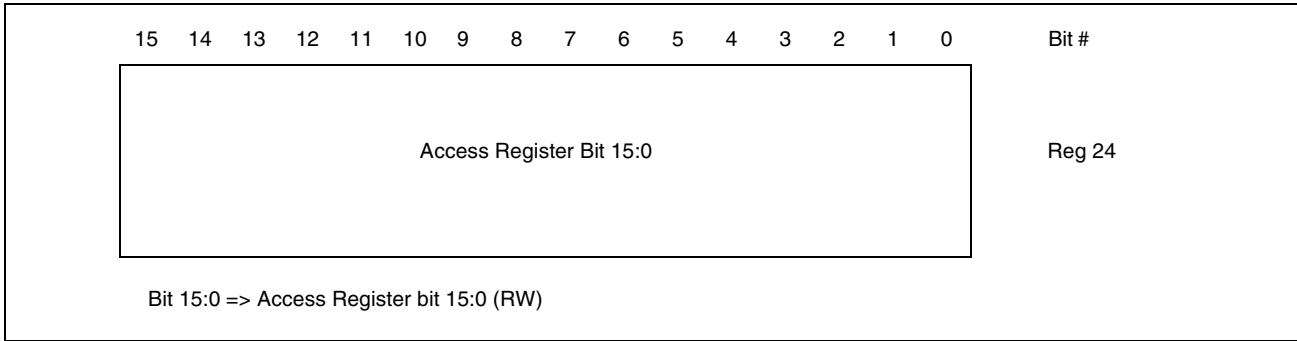

**Figure 29: Pseudo PHY MII Register 24: Access Register Bit Definition**

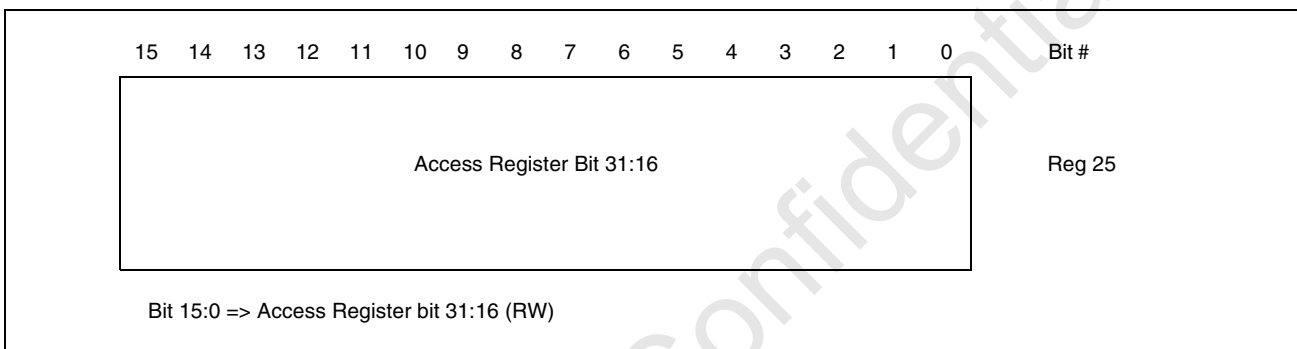

**Figure 30: Pseudo PHY MII Register 25: Access Register Bit Definition**

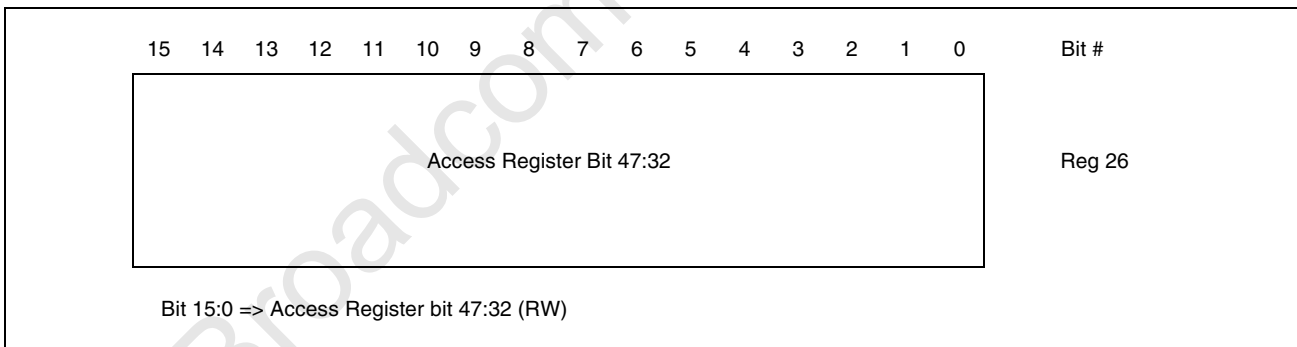

**Figure 31: Pseudo PHY MII Register 26: Access Register Bit Definition**

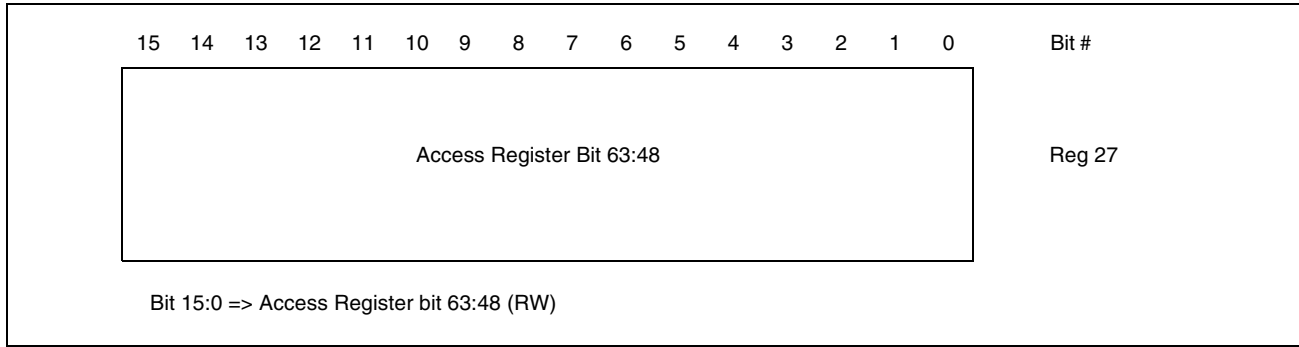

**Figure 32: Pseudo PHY MII Register 27: Access Register Bit Definition**

Broadcom Confidential



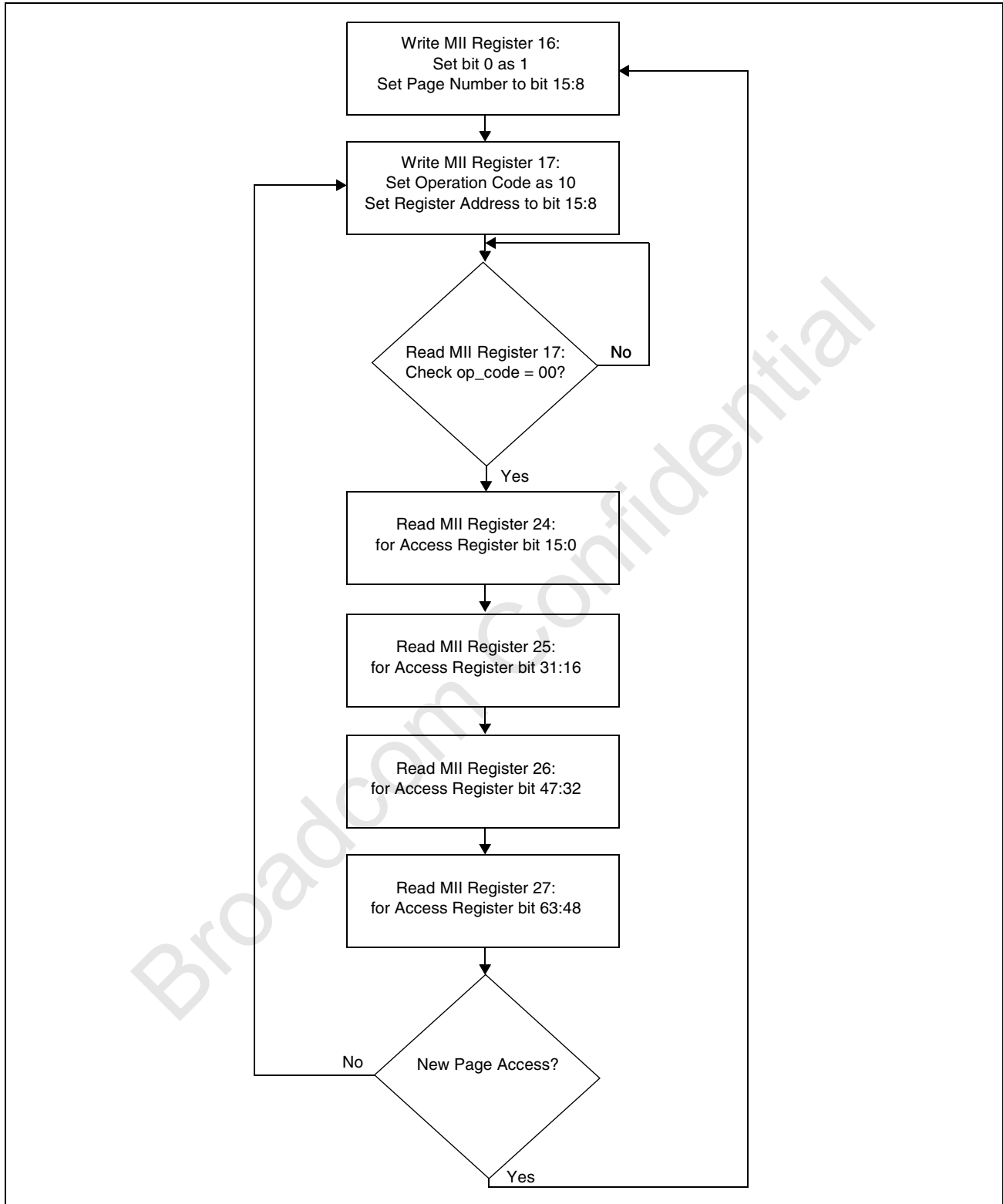

Figure 33: Read Access to the Register Set Via the Pseudo PHY (Phyad = 11110) MDC/MDIO Path

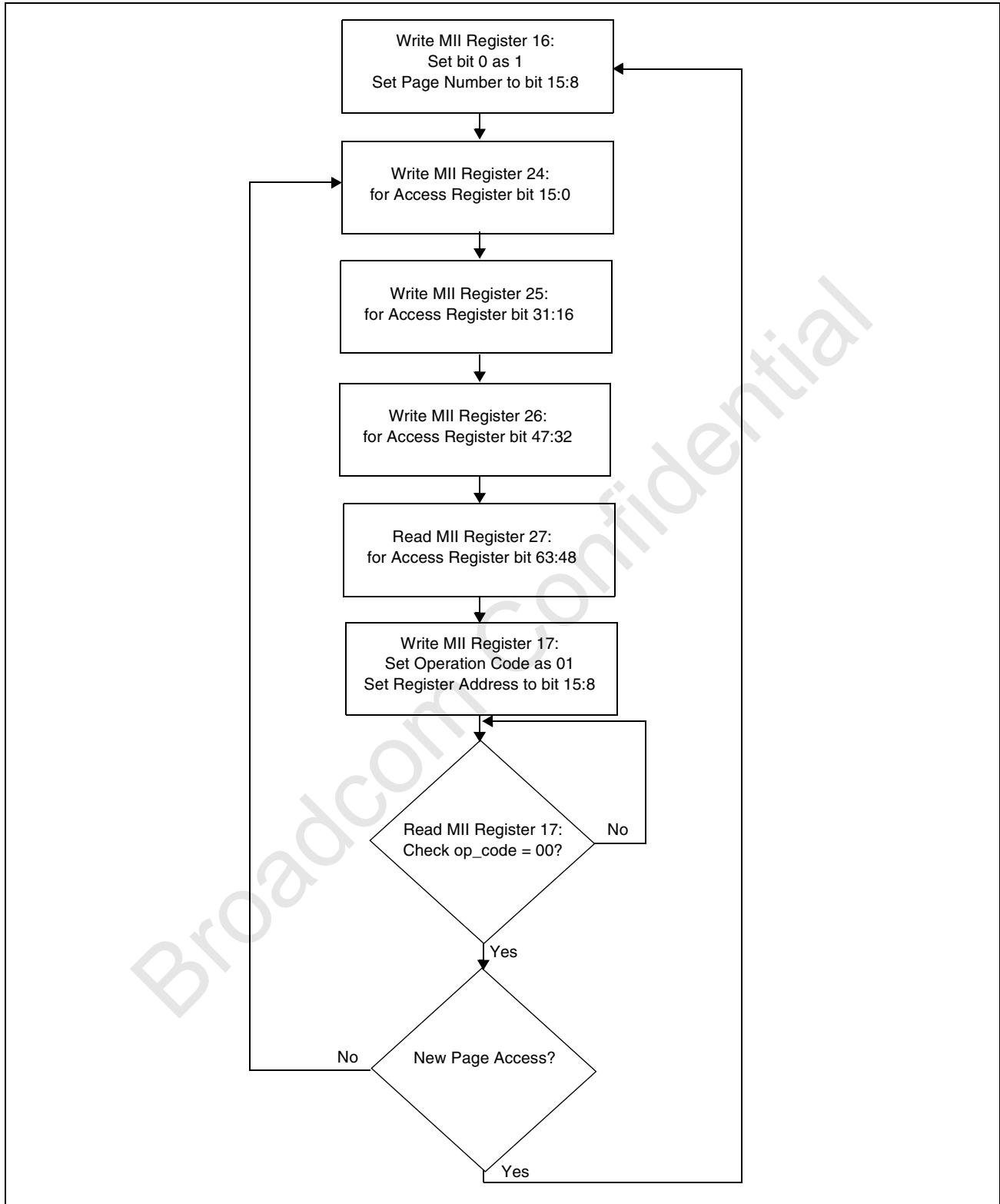

Figure 34: Write Access to the Register Set Via the Pseudo PHY (Phyad = 11110) MDC/MDIO Path

## LED Interfaces

The BCM53242M series consists of several devices with different port configurations. The serial LED shift sequence for all these devices is identical except for the difference in port configuration. [Figure 35 on page 124](#) shows the typical serial LED bit stream in the highest port count configuration. [Table 38](#) shows the valid serial LED bit stream for the specific device.

**Table 38: Valid Serial LED Bit Stream Port Map**

Device	Valid FE Stream	Null FE Stream	Valid GE Stream
BCM53242M	P0 ~ P23	None	G0, G1

The BCM53242M provides visibility for up to 5 status indications per port. A serial interface is supplied to drive the status to the LEDs. The serial interface provides per port of link status, port speed, duplex mode, combined transmit and receive activity, and collision. During power-on and reset, the serial interface shifts a continuous low value for 1.34s.

### Serial LED Interface

A two-pin serial interface, LEDDATA and LEDCLK, provides data and clock to enable external shift registers to capture the LED status indications from the BCM53242M for each internal port. The LED status of the MII port is excluded since it is intended for use as an IMP port. The status encapsulated within the shift sequence is configured by the LED mode configuration signals. The configuration signals select both the number of status bits per port and the status type of each bit.

The LEDCLK is generated by dividing the 25-MHz input clock by 8, providing a 320-ns clock period. The LEDDATA outputs are generated on the falling edge of the LEDCLK, and have adequate setup and hold time to be clocked externally on the rising edge of LEDCLK.

The shift sequence is per port Status words. Each port status word contains up to 5 bit for the designated LED status type as mentioned above. Port 0 status word is shifted out first, followed by Port 1, ..., Port 23 and GigaPort G0 and G1 status words. The shift sequence is repeated every 42 ms.

Refer to [Figure 35 on page 124](#) for an illustration of the serial LED shift sequence, [Table 39: "LED Status Types," on page 124](#) for LED status Type, and [Table 40 on page 125](#) for LED mode matrix.

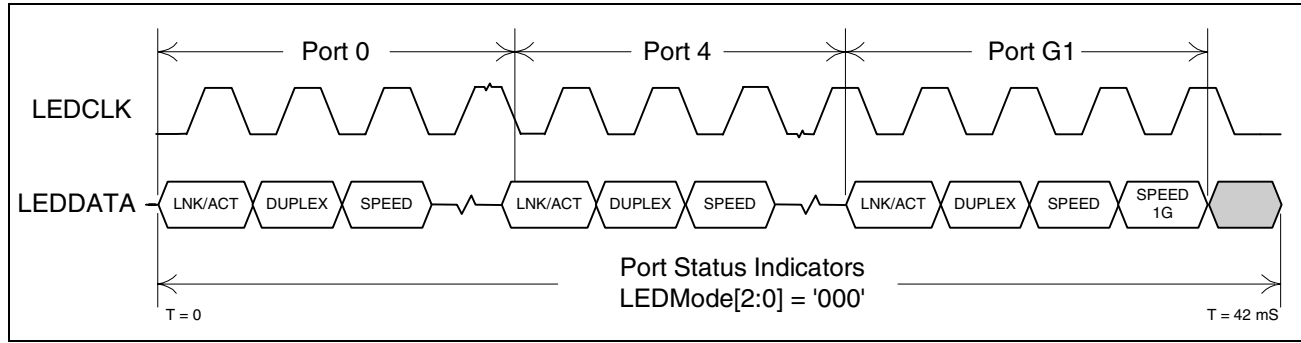

Figure 35: Serial LED Shift Sequence LEDMODE[2:0] = '000'

Table 39: LED Status Types

Name	Description
LNK	<b>Link status indicator.</b> Low when link is established. High when link is off.
LNK/ACT	<b>Link and Activity status indicator.</b> Low when link is established. Blinking at 12 Hz when link is up and port is transmitting and receiving.
LNK/ACT/SPD	<b>Link, Activity and Speed indicator.</b> Low when link is up. Blinking at 3 Hz when port has activity (transmitting or receiving) in 10-Mb mode. Blinking at 6 Hz when there is activity at 100-Mb mode and blinking at 12 Hz when activity in 1000-Mb mode.
LNKG/ACTF	<b>1G Link, 10/100 Activity indicator.</b> Low when 1000-Mb link is up. Blinking at 12 Hz when there is activity in 10 Mb/100 Mb mode. High in all other cases.
LNKF/ACTG	<b>10/100 Link, 1G Activity indicator.</b> Low when 10 Mb/100 Mb link is up. Blinking at 12 Hz when there is activity in 1000-Mb mode. High in all other cases.
DUPLEX	<b>Duplex mode indicator.</b> High for half-duplex or no link, and low for full-duplex and link.
DPX/COL	<b>Duplex and Collision indicator.</b> Blinking when collision is detected. Low for full-duplex and link.
SPEED	<b>Speed indicator.</b> High for 10 Mbps or no link. Low for 100 Mbps and link
SPEED1G	<b>Speed indicator.</b> Low for link at 1000 Mbps. High for all other conditions.
ACT	<b>Activity.</b> Low for 42 ms when transmit or receive activity is detected during previous 42-ms interval. High during no activity or no link.
COLSN	<b>Collision.</b> Low for 42 ms when collision is detected during the previous 42-ms interval. High in the absence of collisions or no link.

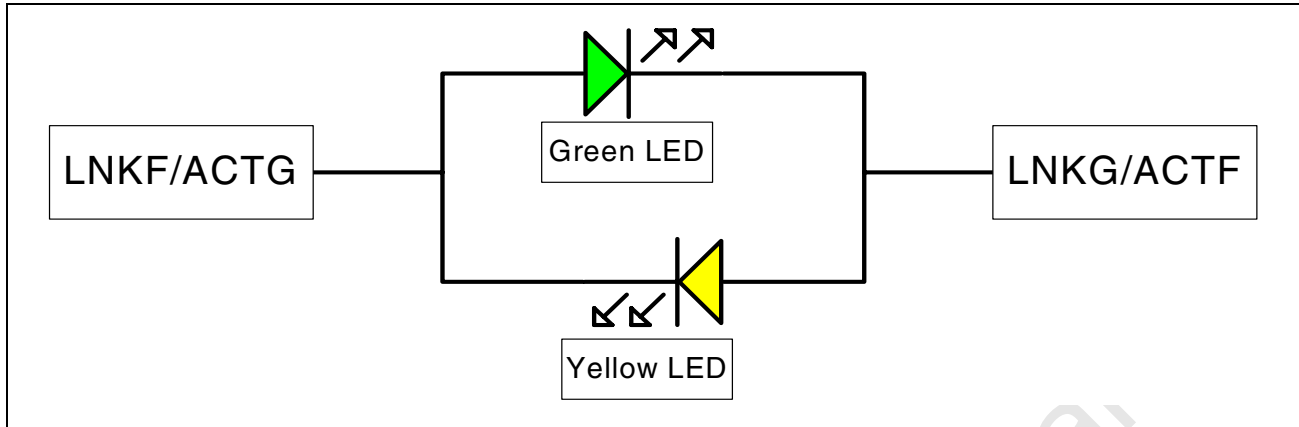

Figure 36: Bicolor LINK/ACT LED Scheme

Table 40: Serial LED Mode Matrix Shift Sequence

LED Mode [2:0]	Port 0 Status	Port 1 Status	Port 2-22	Port 23 Status	Port G0 Status	Port G1 Status
000	LNK/ACT DUPLEX SPEED	LNK/ACT DUPLEX SPEED	....	LNK/ACT DUPLEX SPEED	LNK/ACT DUPLEX SPEED SPEED1G	LNK/ACT DUPLEX SPEED SPEED1G
001	LNK/ACT/SPD DUPLEX	LNK/ACT/SPD DUPLEX	....	LNK/ACT/SPD DUPLEX	LNK/ACT/SPD DUPLEX	LNK/ACT/SPD DUPLEX
010	LNK ACT DUPLEX SPEED	LNK ACT DUPLEX SPEED	....	LNK ACT DUPLEX SPEED	LNK ACT DUPLEX SPEED SPEED1G	LNK ACT DUPLEX SPEED SPEED1G
011 <sup>a</sup>	LNKG/ACTF LNKF/ACTG DPX/COL	LNKG/ACTF LNKF/ACTG DPX/COL	....	LNKG/ACTF LNKF/ACTG DPX/COL	LNKG/ACTF LNKF/ACTG DPX/COL	LNKG/ACTF LNKF/ACTG DPX/COL
100	LNK/ACT DUPLEX COLSN SPEED	LNK/ACT DUPLEX COLSN SPEED	....	LNK/ACT DUPLEX COLSN SPEED	LNK/ACT DUPLEX COLSN SPEED SPEED1G	LNK/ACT DUPLEX COLSN SPEED SPEED1G
101	LNK/ACT/SPD DUPLEX COLSN	LNK/ACT/SPD DUPLEX COLSN	....	LNK/ACT/SPD DUPLEX COLSN	LNK/ACT/SPD DUPLEX COLSN	LNK/ACT/SPD DUPLEX COLSN
110 <sup>a</sup>	LNKG/ACTF LNKF/ACTG	LNKG/ACTF LNKF/ACTG	....	LNKG/ACTF LNKF/ACTG	LNKG/ACTF LNKF/ACTG	LNKG/ACTF LNKF/ACTG

**Table 40: Serial LED Mode Matrix Shift Sequence (Cont.)**

<b>LED Mode [2:0]</b>	<b>Port 0 Status</b>	<b>Port 1 Status</b>	<b>Port 2-22</b>	<b>Port 23 Status</b>	<b>Port G0 Status</b>	<b>Port G1 Status</b>
111	LNK/ACT	LNK/ACT		LNK/ACT	LNK/ACT	LNK/ACT
	DPX/COL	DPX/COL	....	DPX/COL	DPX/COL	DPX/COL
	SPEED	SPEED		SPEED	SPEED	SPEED
					SPEED1G	SPEED1G



**Note:** a = LNKG/ACTF and LNKF/ACTG are for driving dual color LEDs only. See [Figure 36 on page 125](#).

## Programming LED Registers

The BCM53242M implements a versatile LED scheme. To obtain the shift sequence as outlined in [Table 40: “Serial LED Mode Matrix Shift Sequence,” on page 125](#), program the LED register using [Table 41](#).

**Table 41: BCM53242M Legacy LED Shift Sequence Register Programming**

<b>LED_Mode[2:0]</b>	<b>000</b>	<b>001</b>	<b>010</b>	<b>011</b>	<b>100</b>	<b>101</b>	<b>110</b>	<b>111</b>
LED Control Register	0x0583	0x0783	0x0583	0x0583	0x0783	0x0383	0x0583	0x0583
LED Function 0 Control Register	0x0114	0x0110	0x0074	0x0C80	0x011C	0x0118	0x0C00	0x0184
LED Function 1 Control Register	0x0116	0x0110	0x0076	0x3080	0x011E	0x0118	0x3000	0x0186
LED Function Map Register	0x001E_0000_0000_0000							
LED Enable Map Register	0x0006_FFFF_FF00_0000							
LED Mode Map 0 Register	0x001F_FFFF_FFFF_FFFF							
LED Mode Map 1 Register	0x001F_FFFF_FFFF_FFFF							

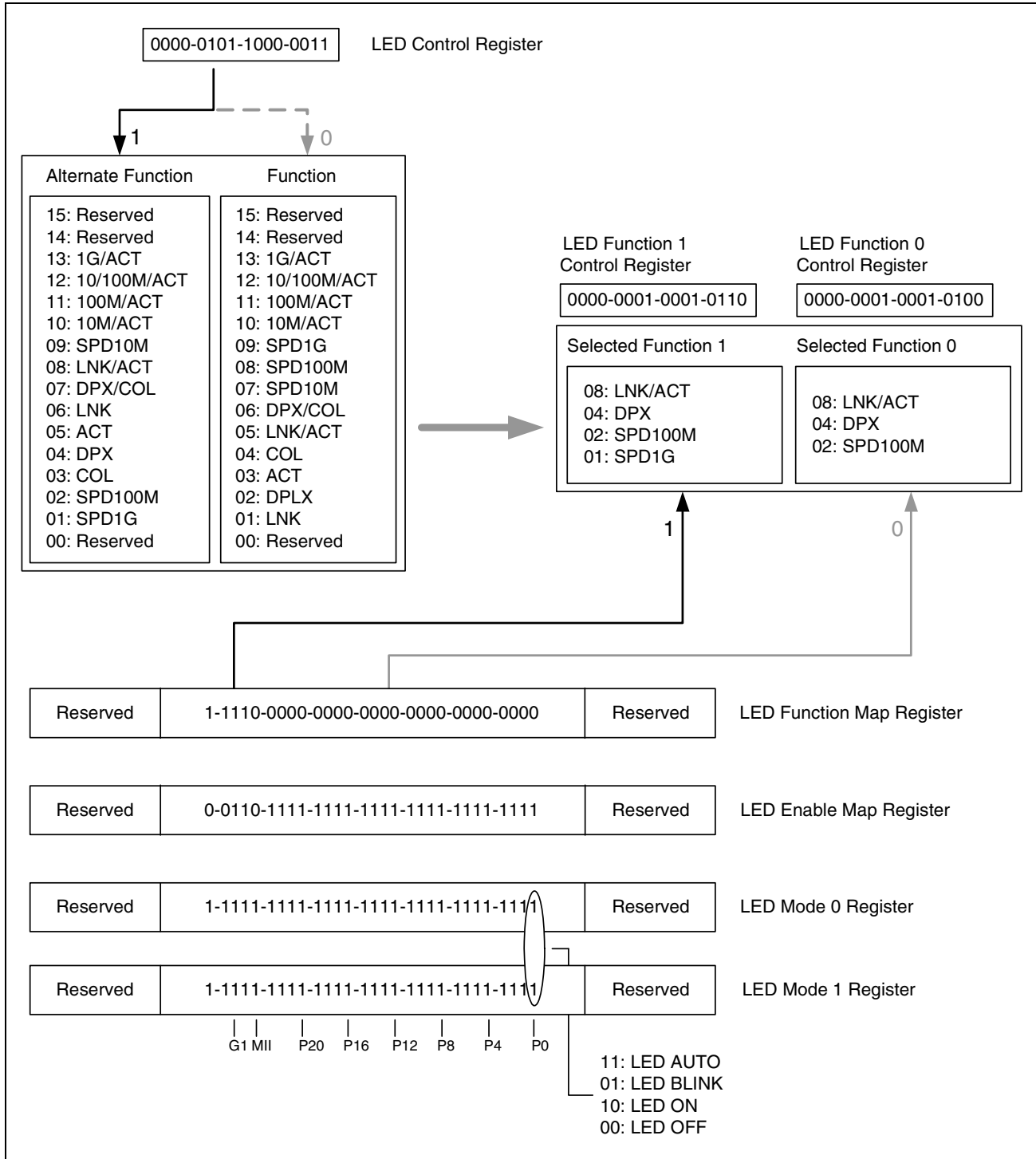

Figure 37: BCM53242 LED Register Structure Diagram



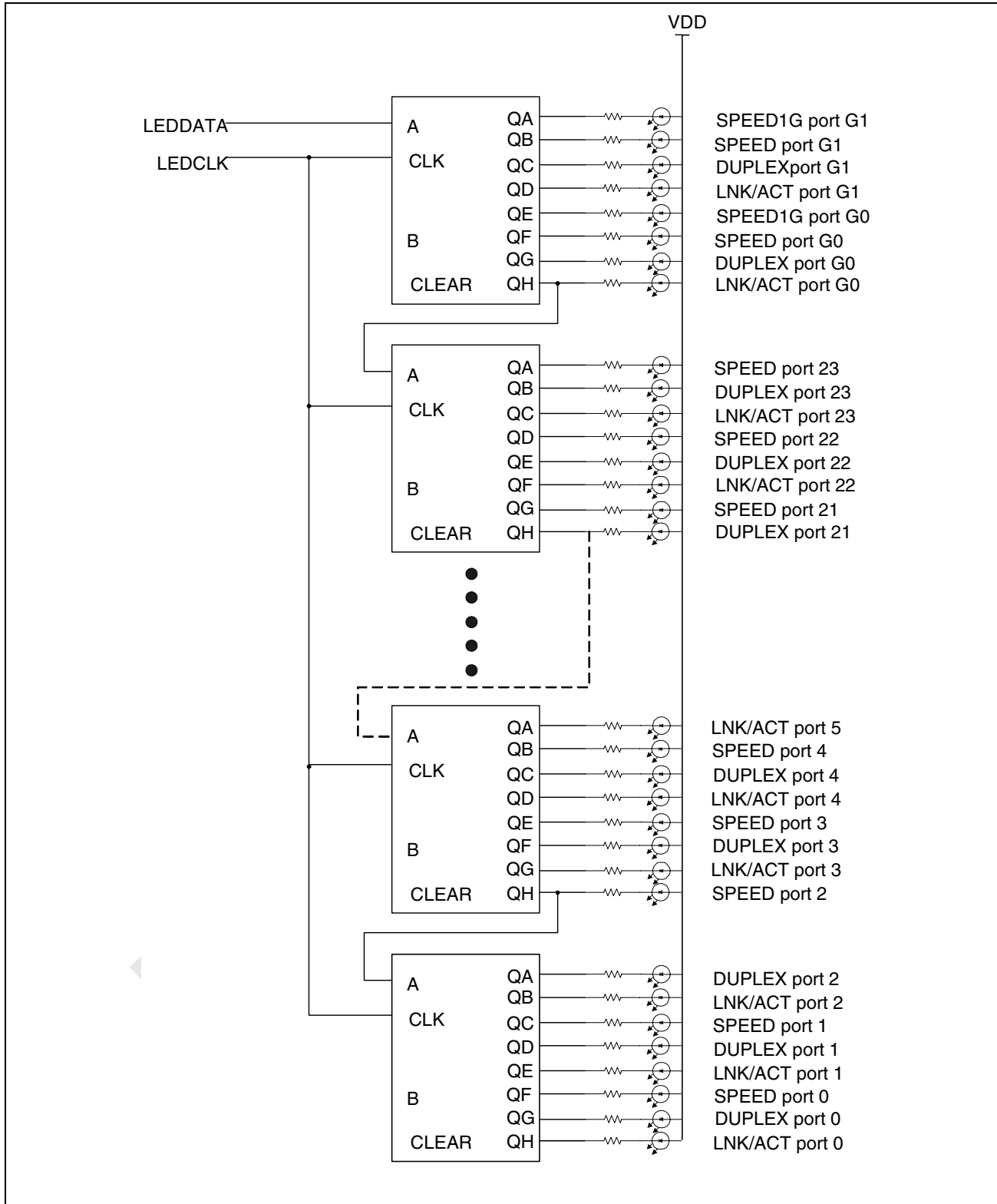

Figure 38: Partial Example External Circuit for Serial LED Mode (LEDMODE[2:0]='000')

---

## JTAG Interface

A standard JTAG interface is provided for boundary scan operations. This interface uses the standard five-pin interface, and supports operation at speeds up to 20 MHz.

---

## Internal Voltage Regulators

Two voltage regulators are provided to ease power supply requirements for system that may otherwise lack 2.5V or 1.2V power supply. An external PNP transistor is required for each of the regulators as show in [Figure 40 on page 131](#). The 1.2V regulator source/emitter pins must be supplied with 2.5V, and the 2.5V regulator source/emitter pins must be supplied with 3.3V. The REGSEN output pins are brought out to allow filtering and power distribution. The REGSENs should not be connected together. Connecting these outputs together can cause one of the regulators to supply all the power or cause the regulators to oscillate.

Place PNP transistors within 0.5 inches of the BCM53242M. The traces connected between PNP pins and BCM53242M device should be at least 5 mils wide. The PNP transistor's emitter and collector should use a plane or a 20-mil or larger trace to prevent IR drops and to ensure a low impedance path. A minimum of one 10- $\mu$ F capacitor with an ESR of less than 0.5 ohms and one 0.1- $\mu$ F output-filter capacitor is needed for the transistor's collector and emitter pin. Place these capacitors within 0.5 inches of the collector pins. For additional margin, the transistor's collector current should be rated at least two times the supply current.

When selecting an external PNP transistor to use for the BCM53242M regulator, the following parameters must be taken into consideration:

- $h_{FE}$  (DC Current Gain) greater than 40, for the operating conditions.
- $V_{CE}$  at the max intended load greater than 300 mV.
- Current capacity greater than that required for the power supply.
- Power dissipation capacity at max system temp and voltage.
- Form factor (size, lead type, surface mount, through-hole, etc).

The Broadcom-recommended external PNP transistors include the MMJT9435 and MJD45H11 from Motorola/ON Semiconductor. Information about these transistors can be found at the OnSemi web site at [www.onsemi.com](http://www.onsemi.com).

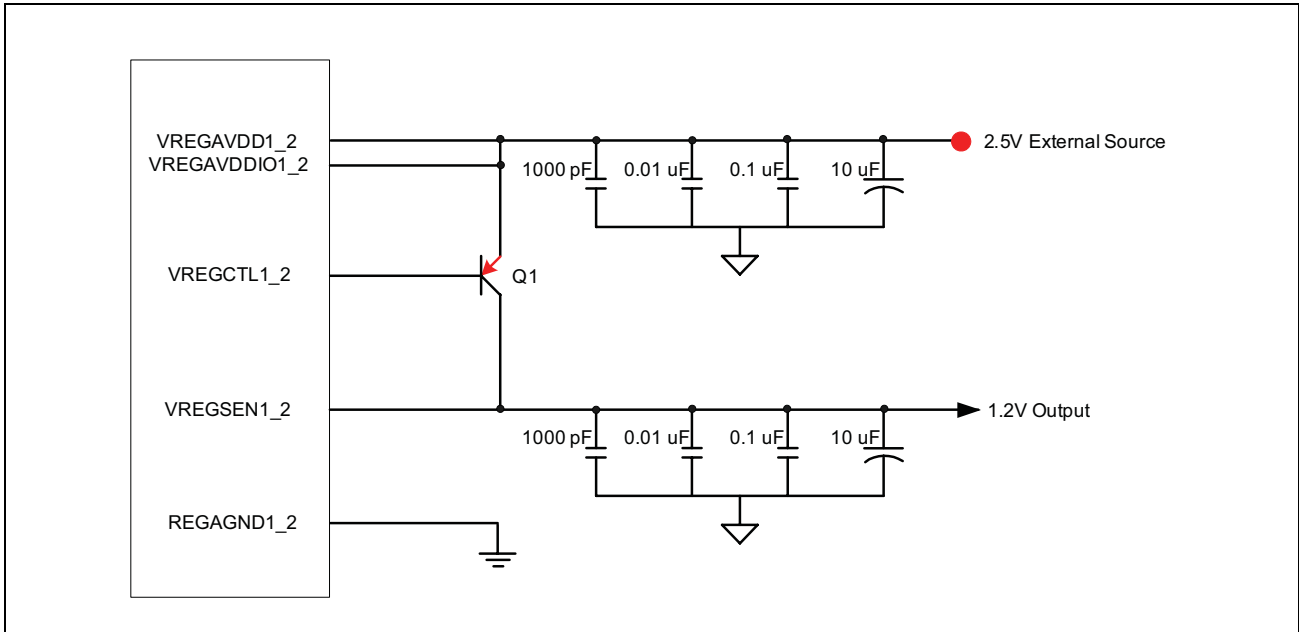

Figure 39: External PNP for 1.2V Voltage Regulators

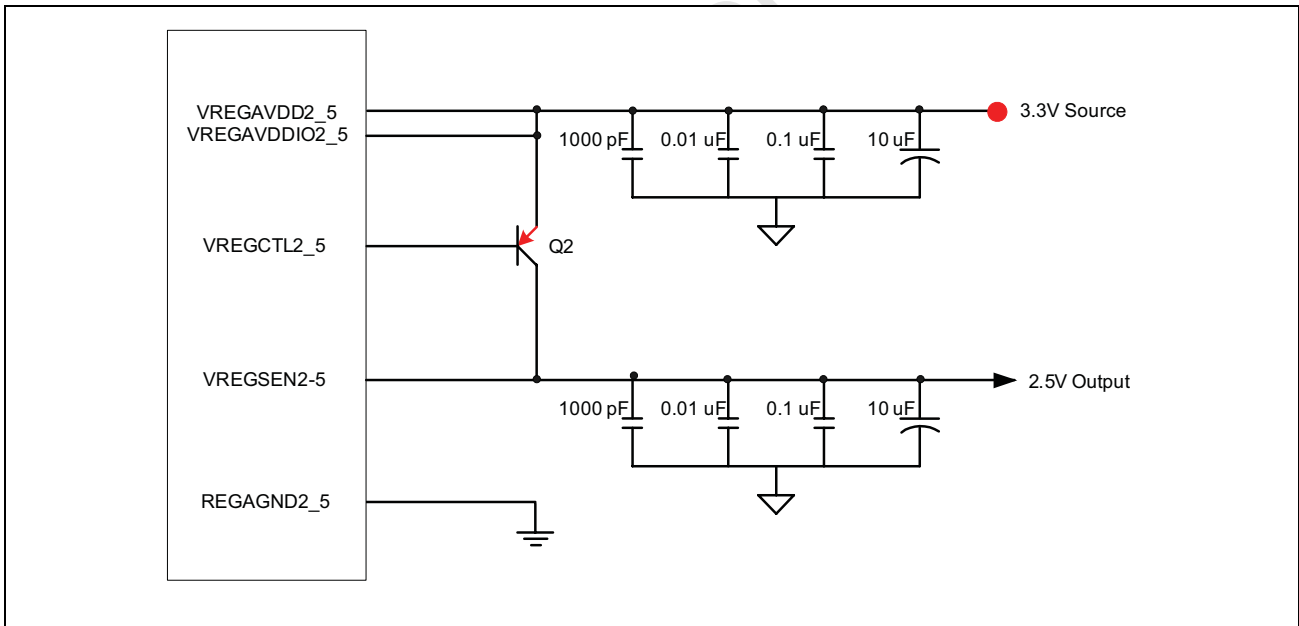

Figure 40: External PNP for 2.5V Voltage Regulators



**Note:** Do not supply the 1.2V regulator from the output of the 2.5V regulator.

## Section 5: BCM53242M Hardware Signal Definitions

Table 42 lists the conventions used to identify the I/O types in Table 43.

**Table 42: I/O Signal Type Definitions**

<b>Type</b>	<b>Description</b>	<b>Type</b>	<b>Description</b>
I	Input	O	Output
I/O	Bi-directional	O <sub>OD</sub>	Open drain output
I <sub>PD</sub>	Input with internal pull-down	O <sub>ODPM</sub>	Open drain power management output
I <sub>PU</sub>	Input with internal pull-up	O <sub>3S</sub>	Tristated signal
I <sub>S</sub>	Input with Schmidt Trigger	B	Bias
GND	Ground	A	Analog
PWR	Power supply	OVERLINE	Active low signal

Pin number in *Italic* font indicates pin is shared with multiple functions.

Configuration of the BCM53242M takes place during reset by loading device control values from hardware strapping pins. Some of the strapping pins are I/O pins and have secondary function during normal device operation. These pins should be configured with external pull-up or pull-down resistors. The strapping value is loaded during the reset sequence and the I/O pin returns to output operation after the completion of reset. Installing a pull-up or pull-down resistor to these pins other than the intended default value can have an adverse affect on the function of the device.

**Table 43: Hardware Signal Definitions**

<b>Signal Name</b>	<b>Ball #</b>	<b>Type</b>	<b>Drive (mA)</b>	<b>Description</b>
<b>Media Connections</b>	–	–	–	–

**Table 43: Hardware Signal Definitions (Cont.)**

<b>Signal Name</b>	<b>Ball #</b>	<b>Type</b>	<b>Drive (mA)</b>	<b>Description</b>
RD0+/-	Y1/Y2	I/O <sub>A</sub>	–	<b>Receive Pair.</b> Differential data from the media is received on the RD± signal pair.
RD1+/-	U5/U4			
RD2+/-	Y3/Y4			
RD3+/-	U7/U6			
RD4+/-	Y5/Y6			
RD5+/-	U9/U8			
RD6+/-	Y7/Y8			
RD7+/-	V10/V9			
RD8+/-	U10/U11			
RD9+/-	Y14/Y13			
RD10+/-	U12/U13			
RD11+/-	Y16/Y15			
RD12+/-	U14/U15			
RD13+/-	W17/W16			
RD14+/-	U16/U17			
RD15+/-	W19/W18			
RD16+/-	T19/R19			
RD17+/-	P18/R18			
RD18+/-	P19/N19			
RD19+/-	M18/N18			
RD20+/-	M19/L19			
RD21+/-	H19/G19			
RD22+/-	K19/J19			
RD23+/-	H20/J20			

Table 43: Hardware Signal Definitions (Cont.)

Signal Name	Ball #	Type	Drive (mA)	Description
TD0+/-	W3/W2	I/O <sub>A</sub>	–	<b>Transmit Pair.</b> Differential data is transmitted to the media on the TD± signal pair.
TD1+/-	V3/V4			
TD2+/-	W5/W4			
TD3+/-	V5/V6			
TD4+/-	W7/W6			
TD5+/-	V7/V8			
TD6+/-	W9/W8			
TD7+/-	Y9/Y10			
TD8+/-	V12/V11			
TD9+/-	W12/W13			
TD10+/-	V14/V13			
TD11+/-	W14/W15			
TD12+/-	V16/V15			
TD13+/-	Y17/Y18			
TD14+/-	V18/V17			
TD15+/-	Y19/Y20			
TD16+/-	T20/U20			
TD17+/-	L17/M17			
TD18+/-	P20/R20			
TD19+/-	K18/L18			
TD20+/-	M20/N20			
TD21+/-	H18/J18			
TD22+/-	K20/L20			
TD23+/-	G20/F20			
<b>Clock/Reset</b>				
RESET	C4	I <sub>S,PU</sub>	–	<b>Reset.</b> Active-low. Resets the BCM53242M.
XTALI	V19	I	–	<b>25-MHz Crystal/Clock Input.</b> For a single-ended clock signal input, connect a 25.000 (±50 ppm) MHz reference clock to the XTALI pin. This pin must be driven with a continuous clock. Leave XTALO unconnected for this mode of operation.  Alternatively, a 25.000 MHz parallel-resonant crystal can be connected between the XTALI/XTALO pins, with a 22 pF capacitor from each pin to GND.
XTALO	V20	O		
<b>MII Interface</b>				
CRS	D9	I <sub>PD</sub>	–	<b>Carrier Sense.</b> Active-high. Indicates traffic on link.
COL	C9	I <sub>PD</sub>	–	<b>Collision Detect.</b> In half-duplex mode, active-high input indicates that a collision has occurred. In full-duplex mode, COL remains low. COL is an asynchronous input signal.

**Table 43: Hardware Signal Definitions (Cont.)**

<b>Signal Name</b>	<b>Ball #</b>	<b>Type</b>	<b>Drive (mA)</b>	<b>Description</b>
MDIO	C5	I/O <sub>PD</sub>	8	<b>Management Data I/O.</b> This serial input/output bit is used to read from and write to the MII registers of the internal transceivers. The input data value on the MDIO pin is valid and latched on the rising edge of MDC.
MDC	B5	I/O <sub>PD</sub>	8	<b>Management Data Clock.</b> MDC must be provided to the BCM53242M as an input to allow MII management functions. Clock frequencies up to 12.5 MHz are supported. If the BCM53242M detects SCK activity on the SPI interface, the BCM53242M sources a 2.5-MHz clock to the external PHY device.
RXCLK	B7	I/O <sub>PD</sub>	8	<b>Receive Clock.</b> 25 MHz input in 100Base-X mode and 2.5 MHz input in 10Base-T mode. RXC is expected to be continuously running. RXC may have an irregular period when RXDV= 0 at the beginning of a packet.
RXD[3]	A5	I <sub>PD</sub>	–	<b>Receive Data Inputs.</b> Nibble-wide receive data. RXD[3] is the most significant bit.
RXD[2]	C6	I <sub>PD</sub>	–	
RXD[1]	B6	I <sub>PD</sub>	–	
RXD[0]	A6	I <sub>PD</sub>	–	
RXDV	A7	I <sub>PD</sub>	–	<b>Receive Data Valid.</b> Active-high. Indicates that a receive frame is in progress, and that the data stream present on the RXD input pins is valid.
RXER	C7	I <sub>PD</sub>	–	<b>Receive Error Detected.</b> Active-high. Indicates that there has been an error during a receive frame.
TXCLK	A8	I/O <sub>PD</sub>	8	<b>Transmit Clock.</b> For MII mode, 25 MHz input in 100Base-X mode and 2.5 MHz in 10Base-T mode. This clock must be a continuously driven input, generated from the PHY.
TXD[3]	B9	I/O <sub>PU</sub>	8	<b>Transmit Data Output.</b> Nibble-wide transmit data is output on these pins synchronously to TXC. TXD[3] is the most significant bit.
TXD[2]	A9			
TXD[1]	D8			
TXD[0]	C8			
TXEN	B8	I/O <sub>PD</sub>	8	<b>Transmit Enable.</b> Indicates that the data nibble is valid on TXD[3:0].
TXER	D7	I/O <sub>PD</sub>	8	<b>Transmit Error.</b> Asserted while TXEN is active to force a bad code into the transmit data stream.
<b>MII Interface Configuration</b>				
RvMII_EN	C1	I/O <sub>PD</sub>	–	<b>MII or Reversed MII Interface Selection.</b> Set to enable MII Interface to appear as a 100 Mbps full duplex PHY MII, as seen by the external MAC. Under this mode, the TXCLK/RXCLK become 25-MHz clock outputs.

**Table 43: Hardware Signal Definitions (Cont.)**

<b>Signal Name</b>	<b>Ball #</b>	<b>Type</b>	<b>Drive (mA)</b>	<b>Description</b>
<b>Dual GMII/RGMII/MII/TBI Interfaces</b>				
<b>Note:</b> If not used, all GMII input pins should be pulled-down. All GMII output pins can be left floating if not used.				
GMII1_CRS	A17	I	–	<b>Carrier Sense.</b> Active-high. Indicates traffic on link. GMII(0:1)_CRS is asserted when a non-idle condition is detected in the receive data stream. GMII(0:1)_CRS is deasserted when idle or a valid end of stream delimiter is detected. In half-duplex mode, GMII(0:1)_CRS is also asserted during transmission of packets. GMII(0:1)_CRS is an asynchronous input signal.
GMII0_CRS	K17			
GMII1_COL	C16	I	–	<b>Collision Detect.</b> Active-high. Indicates collision on the link. GMII(0:1)_COL is asserted when both GMII(0:1)_TX_EN and GMII(0:1)_CRS are high in half-duplex operation. This is only valid for MII operation. In full-duplex mode, GMII(0:1)_COL remains low. GMII(0:1)_COL is an asynchronous input signal.
GMII0_COL	J17			
GMII1_GTXCLK	A13	O	–	<b>Transmit Clock.</b> 125-MHz Output. This clock is continuously driven from the MAC. It is used to synchronize the transmit data in 1000Base-T (GMII, TBI, or RGMII) mode.
GMII0_GTXCLK	C20			
MII1_TXC	A10	I/O	–	<b>MII Transmit Clock.</b> This clock is used to synchronize the transmit data in MII mode. This clock input is 25-MHz in 100Base-TX mode and 2.5-MHz in 10Base-T mode. This clock must be a continuously driven input, generated from the PHY.
MII0_TXC	D17			



**Table 43: Hardware Signal Definitions (Cont.)**

<b>Signal Name</b>	<b>Ball #</b>	<b>Type</b>	<b>Drive (mA)</b>	<b>Description</b>
GMII1_TXD[7]	C12	O	–	<b>Transmit Data Outputs.</b> Byte-wide transmit data is output synchronous to the GMII or MII Transmit Clock. GMII(0:1)_TXD[7] is the most significant bit. GMII(0:1)_TXD[7:0] are used in GMII and TBI mode.  In 10Base-T, 100Base-TX, and RGMII mode, only GMII(0:1)_TXD[3:0] are used. GMII(0:1)_TXD[3] is the most significant bit.
GMII1_TXD[6]	B12			
GMII1_TXD[5]	A12			
GMII1_TXD[4]	C11			
GMII1_TXD[3]	B11			
GMII1_TXD[2]	A11			
GMII1_TXD[1]	C10			
GMII1_TXD[0]	B10			
GMII0_TXD[7]	C19			
GMII0_TXD[6]	B19			
GMII0_TXD[5]	A19			
GMII0_TXD[4]	C18			
GMII0_TXD[3]	B18			
GMII0_TXD[2]	A18			
GMII0_TXD[1]	C17			
GMII0_TXD[0]	B17			
GMII1_TX_EN	D11	O	–	<b>Transmit Enable.</b> Active-high. When GMII(0:1)_TX_EN is asserted, the data on the GMII(0:1)_TXD pins is encoded and transmitted. GMII(0:1)_TX_ER are used as GMII(0:1)_TXD[9] in TBI mode.
GMII0_TX_EN	A20			
GMII1_TX_ER	D12	O	–	<b>Transmit Error.</b> Active-high. Asserting GMII(0:1)_TX_ER when GMII(0:1)_TX_EN is high causes transmission of the designated bad code in lieu of normal encoded data.
GMII0_TX_ER	B20			
GMII1_RXCLK	B13	I	–	<b>Receive Clock.</b> 2.5/25/125-MHz input. This clock is recovered from the incoming analog waveforms and is used to synchronize the receive data: <ul style="list-style-type: none"> <li>• 1000Base-TX mode; the clock is 125 MHz, byte-aligned on GMII(0:1)_RXD[7:0].</li> <li>• 100Base-TX mode; the clock is 25 MHz, nibble-aligned on GMII(0:1)_RXD[3:0].</li> <li>• 10Base-T mode; the clock is 2.5 MHz, nibble-aligned on GMII(0:1)_RXD[3:0].</li> </ul>
GMII0_RXCLK	D20			

**Table 43: Hardware Signal Definitions (Cont.)**

<b>Signal Name</b>	<b>Ball #</b>	<b>Type</b>	<b>Drive (mA)</b>	<b>Description</b>
GMII1_RXD[7]	A14	I	–	<b>Receive Data Input.</b> Byte-wide receive data is driven into these signals synchronous with the receive clock GMII(0:1)_RXC. GMII(0:1)_RXD[7] is the most significant bit. GMII(0:1)_RXD[7:0] are used in GMII and TBI mode. In 10Base-T, 100Base-TX, and RGMII mode, only GMII(0:1)_RXD[3:0] are active. GMII(0:1)_RXD[3] is the most significant bit.
GMII1_RXD[6]	B14			
GMII1_RXD[5]	C14			
GMII1_RXD[4]	A15			
GMII1_RXD[3]	B15			
GMII1_RXD[2]	C15			
GMII1_RXD[1]	A16			
GMII1_RXD[0]	B16			
GMII0_RXD[7]	E19			
GMII0_RXD[6]	E20			
GMII0_RXD[5]	F18			
GMII0_RXD[4]	F19			
GMII0_RXD[3]	G18			
GMII0_RXD[2]	F17			
GMII0_RXD[1]	G17			
GMII0_RXD[0]	H17			
GMII1_RXDV	D15	I	–	<b>Receive Data Valid.</b> Active-high. GMII(0:1)_RX_DV indicates that a receive frame is in progress and that the data present on the RXD input pins is valid. GMII(0:1)_RXDV are used as GMII(0:1)_RXD[8] in TBI mode.
GMII0_RXDV	E18			
GMII1_RXER	D14	I	–	<b>Receive Error Detected.</b> Active-high. An illegal code or some other coding violation has been detected in the data received from the twisted-pair medium when both GMII(0:1)_RX_DV and GMII(0:1)_RX_ER are high. GMII(0:1)_RXER are used as GMII(0:1)_RXD[9] in TBI mode.
GMII0_RXER	E17			
GMII1_SD	D10	I	–	<b>Fiber Signal Detect.</b> Active high. When the GMII interface operates in 1000Base-SX or 1000Base-LX mode. This signal is an output from the external fiber module that indicate a valid optical fiber signal.
GMII0_SD	D16			
TBI1_RBC[1]	C13	I	–	<b>TBI Receive Clocks.</b> Complementary single-ended 62.5-MHz receive clocks used by the TBI.
TBI1_RBC[0]	D13			
TBIO_RBC[1]	D18			
TBIO_RBC[0]	D19			

**Table 43: Hardware Signal Definitions (Cont.)**

<b>Signal Name</b>	<b>Ball #</b>	<b>Type</b>	<b>Drive (mA)</b>	<b>Description</b>
<b>Bias</b>				
RDAC[2]	R17	B	–	<b>DAC Bias Resistor.</b> Adjusts the drive level of the transmit DAC. Three separate 1% precision resistors must be connected between the RDAC pins and GND.  All the specific register information is temporary and subject to be change in the final version of the data sheet.
RDAC[1]	W20			
RDAC[0]	W10			
<b>LEDs</b>				
LEDMODE[2]	E4	I <sub>PU</sub>	–	<b>LED Mode.</b> See <a href="#">Table 40: “Serial LED Mode Matrix Shift Sequence,”</a> on page 125 for details.
LEDMODE[1]	C3	I <sub>PD</sub>		
LEDMODE[0]	B2	I <sub>PD</sub>		
LEDCLK	E2	O	8	<b>LED Shift Clock.</b> Periodically active to enable the shift of LEDDATA into external registers.
LEDDATA	F3	O	8	<b>LED Data Output.</b> Serial LED data is shifted out when LEDCLK is active. Refer to <a href="#">Table 39: “LED Status Types,”</a> on page 124 and <a href="#">Table 40: “Serial LED Mode Matrix Shift Sequence,”</a> on page 125 for a functional description of these signals.
<b>SPI</b>				
MISO	B3	O <sub>3S</sub>	8	<b>Master-In/Slave-Out.</b> Output signal from the BCM53242M driven with serial data during a Serial Management Port Read operation. Shared with EEPROM’s DO.
MOSI	A3	I <sub>PU</sub>	–	<b>Master-Out/Slave-In.</b> Input signal which receives control and address information for the Serial Management Port, as well as serial data during Write operations. Shared with EEPROM’s DI.
SCK	D5	I/O <sub>PD</sub>	8	<b>Serial Clock.</b> Clock input to the Serial Management Port supplied by the SPI master. Supports up to 2 MHz. Shared with EEPROM’s SCK.
SS	D4	I/O <sub>PU</sub>	8	<b>Slave Select.</b> Active-low signal which enables a Serial Management Port Read or Write operation. Shared with the EEPROM’s CS.
<b>EEPROM</b>				
CS	D4	O <sub>PU</sub>	8	<b>Chip Select.</b> Active-high signal which enables an EEPROM read operation. Shared with SPI’s SS.
DI	A3	O <sub>PU</sub>	8	<b>Data In.</b> Serial data input to the external EEPROM. Shared with SPI’s MOSI.

**Table 43: Hardware Signal Definitions (Cont.)**

<b>Signal Name</b>	<b>Ball #</b>	<b>Type</b>	<b>Drive (mA)</b>	<b>Description</b>
DO	B3	I <sub>PU</sub>	–	<b>Data Out.</b> Serial data output from the external EEPROM. Shared with SPI's MISO.
SCK	D5	O <sub>PD</sub>	8	<b>Serial Data Clock.</b> Clock output to the EEPROM supplied by the BCM53242M. Shared with SPI's SCK.
<b>Test Interface</b>				
TCK	H3	I <sub>PU</sub>	–	<b>JTAG Test Clock Input.</b> Clock input used to synchronize JTAG control and data transfers. If unused, may be left unconnected.
TDI	G1	I <sub>PU</sub>	–	<b>JTAG Test Data Input.</b> Serial data input to the JTAG TAP Controller. Sampled on the rising edge of TCK. If unused, may be left unconnected.
TDO	H2	O <sub>3S</sub>	8	<b>JTAG Test Data Output.</b> Serial data output from the JTAG TAP Controller. Updated on the falling edge of TCK. Actively driven both high and low when enabled; high impedance otherwise.
TMS	G2	I <sub>PU</sub>	–	<b>JTAG Mode Select Input.</b> Single control input to the JTAG TAP Controller used to traverse the test-logic state machine. Sampled on the rising edge of TCK. If unused, may be left unconnected.
TRST	F1	I <sub>PU</sub>	–	<b>JTAG Test Reset.</b> Asynchronous active-low reset input to the JTAG TAP Controller. The TRST input must be driven low to insure the TAP controller initializes to the proper state. <b>Note:</b> A 4.7K external pull-down resistor is required on this pin to ensure proper initialization.
<b>Configuration</b>				
CPU_EEPROM_SEL	F4	I/O <sub>PU</sub>	–	<b>CPU or EEPROM Interface Selection.</b> <ul style="list-style-type: none"> <li>CPU_EEPROM_SEL = 0: Disables SPI interface, and allows for connection to EEPROM.</li> <li>CPU_EEPROM_SEL = 1: Configures SPI interface to connect to CPU.</li> </ul>
EEPROM_TYPE1	C2	I/O <sub>PD</sub>	–	<b>EEPROM Type Select.</b> The EEPROM type is automatically detected by the BCM53242M. These two strap pins are essentially don't cares and can be ignored. See <a href="#">“EEPROM Interface” on page 112</a> for more information.
EEPROM_TYPE0	D3	I/O <sub>PD</sub>	–	
ENFDXFLOW	E9	I/O <sub>PU</sub>	–	<b>Enable Automatic Full Duplex Flow Control.</b> In combination with the results of auto-negotiation, sets the flow control mode. Refer to <a href="#">Table 8: “Flow Control Modes,” on page 77</a> for more information.

**Table 43: Hardware Signal Definitions (Cont.)**

<b>Signal Name</b>	<b>Ball #</b>	<b>Type</b>	<b>Drive (mA)</b>	<b>Description</b>
ENHDXFLOW	E10	I/O <sub>PU</sub>	–	<p><b>Enable Automatic Backpressure.</b></p> <ul style="list-style-type: none"> <li>ENHDXFLOW = 0: 10/100 ports half-duplex flow control is disabled.</li> <li>ENHDXFLOW = 1: 10/100 ports half-duplex flow control is enabled.</li> </ul> <p>See <a href="#">Table 8: “Flow Control Modes,”</a> on page 77 for more information.</p>
EN_GRX_FLOW	E3	I/O <sub>PU</sub>	–	<p><b>Enable Gigabit Receive Flow Control.</b></p> <ul style="list-style-type: none"> <li>EN_GRX_FLOW = 0: Gigabit ports Half-duplex flow control is disabled.</li> <li>EN_GRX_FLOW = 1: Gigabit ports Half-duplex flow control is enabled.</li> </ul>
HW_FWDG_EN	A2	I/O <sub>PU</sub>	–	<p><b>Forwarding Enable.</b></p> <ul style="list-style-type: none"> <li>HW_FWDG_EN = 0: Frame forwarding is disabled at power-up. Typically implemented to support compliant 802.1 Spanning Tree Protocol in a managed application.</li> <li>HW_FWDG_EN = 1: Frame forwarding is enabled (typical for unmanaged applications).</li> </ul>
MDIX_DIS	E13	I/O <sub>PD</sub>	–	<p><b>HP Auto-MDIX Disable.</b></p> <ul style="list-style-type: none"> <li>MDIX_DIS = 0: Automatic TX cable swap detection enabled.</li> <li>MDIX_DIS = 1: Automatic TX cable swap detection disabled.</li> </ul>
GIGAO_IFSEL[1]	D2	I/O <sub>PD</sub>	–	<p><b>Giga-Port G0 Interface Select.</b></p> <ul style="list-style-type: none"> <li>GIGAO_IFSEL[1:0] = 11: MII</li> <li>GIGAO_IFSEL[1:0] = 10: GMII</li> <li>GIGAO_IFSEL[1:0] = 01: TBI</li> <li>GIGAO_IFSEL[1:0] = 00: RGMII</li> </ul>
GIGAO_IFSEL[0]	F5			
GIGA1_IFSEL[1]	G4	I/O <sub>PD</sub>	–	<p><b>Giga-Port G1 Interface Select.</b></p> <ul style="list-style-type: none"> <li>GIGA1_IFSEL[1:0] = 11: MII</li> <li>GIGA1_IFSEL[1:0] = 10: GMII</li> <li>GIGA1_IFSEL[1:0] = 01: TBI</li> <li>GIGA1_IFSEL[1:0] = 00: RGMII</li> </ul>
GIGA1_IFSEL[0]	D1			
PHY_POLL_DIS	B1	I/O <sub>PD</sub>	–	<p><b>PHY Polling Disable.</b></p> <ul style="list-style-type: none"> <li>Disable External PHY Polling = 1</li> <li>Enable External PHY Polling = 0</li> </ul>

**Table 43: Hardware Signal Definitions (Cont.)**

<b>Signal Name</b>	<b>Ball #</b>	<b>Type</b>	<b>Drive (mA)</b>	<b>Description</b>
<b>Voltage Regulator</b>				
VREGCTL1_2	V2	PWR	–	<b>Low Voltage Regulator Controls.</b> The BCM53242M incorporates two internal low voltage regulators that can be used in conjunction with the external PNP transistor current driver to supply 1.2V and 2.5V. See <a href="#">“Internal Voltage Regulators” on page 130</a> for schematic. <ul style="list-style-type: none"> <li>• The VREGCTL* must be connected to the base of the PNP.</li> <li>• Regulator output sense VREGSEN* must be connected to the collector of the PNP.</li> <li>• The emitter of the PNP must be connected to VREGAVDD and VREGAVDDIO.</li> </ul>
VREGSEN1_2	W1			
VREGCTL2_5	P4			
VREGSEN2_5	R3			
VREGAVDDIO1_2	T4	PWR	–	<b>1.2V Internal Regulator IO VDD.</b> This pin must be supplied with a 2.5V external source.
VREGAVDD1_2	U3	PWR	–	<b>1.2V Internal Regulator VDD.</b> This pin must be supplied with a 2.5V external source.
REGAGND1_2	T3	GND	–	<b>GND.</b>
VREGAVDDIO2_5	U2	PWR	–	<b>2.5V Internal Regulator IO VDD.</b> This pin must be supplied with a 3.3V external source.
VREGAVDD2_5	V1	PWR	–	<b>2.5V Internal Regulator VDD.</b> This pin must be supplied with a 3.3V external source.
REGAGND2_5	T2	GND	–	<b>GND.</b>
<b>Power</b>				
VDDO0	G14, G15, H15, J15	PWR	–	<b>VDDO0.</b> Gigabit 0 interface supply (voltage depends on the interface configuration): <ul style="list-style-type: none"> <li>• GMII = 3.3V</li> <li>• RGMII = 2.5V</li> <li>• MII = 2.5V or 3.3V</li> <li>• TBI = 3.3V</li> </ul>
VDDO1	G11, G12, G13	PWR	–	<b>VDDO0.</b> Gigabit 1 interface supply (voltage depends on the interface configuration): <ul style="list-style-type: none"> <li>• GMII = 3.3V</li> <li>• RGMII = 2.5V</li> <li>• MII = 2.5V or 3.3V</li> <li>• TBI = 3.3V</li> </ul>
VDDO2	G6, G7, G8, G9, G10, H6, J6, K6, L6, M6, T17	PWR	–	<b>2.5V Digital I/O voltage</b>
VDDO3	N6, P6, R4, U1	PWR	–	<b>3.3V if 2.5V regulator is used</b> 2.5V if regulator is not used.
BIASVDD	W11, T18, P17	PWR	–	<b>2.5V Bias Circuit VDD.</b>

**Table 43: Hardware Signal Definitions (Cont.)**

<b>Signal Name</b>	<b>Ball #</b>	<b>Type</b>	<b>Drive (mA)</b>	<b>Description</b>
VDDP	E8, E11, H5, J16, N17	PWR	–	<b>2.5V Digital Periphery VDD.</b>
XTALVDD	U19	PWR	–	<b>2.5V XTAL Circuit VDD.</b>
VDDC	E14, E15, E16, F6, F7, F8, F9, F10, F11, F12, F13, F14, F15, F16, G5, G16, H16, J5, L5, N5	PWR	–	<b>1.2V Digital Core VDD.</b>
GND	H7, H8, H9, H10, H11, H12, H13, H14, J7, J8, J9, J10, J11, J12, J13, J14, K7, K8, K9, K10, K11, K12, K13, K14, L7, L8, L9, L10, L11, L12, L13, L14, M7, M8, M9, M10, M11, M12, M13, M14, N7, N8, N9, N10, N11, N12, N13, N14	GND	–	<b>Digital GND.</b>
AVDDL	K16, L16, M16, N16, P16, T5, T6, T7, T8, T9, T10, T11, T12, T13, T14	PWR	–	<b>1.2V Analog VDD.</b>
AVSS	K15, L15, M15, N15, P5, P7, P8, P9, P10, P11, P12, P13, P14, P15, R5, R6, R7, R8, R9, R10, R11, R12, R13, R14, R15	GND	–	<b>Analog GND.</b>

**Table 43: Hardware Signal Definitions (Cont.)**

<b>Signal Name</b>	<b>Ball #</b>	<b>Type</b>	<b>Drive (mA)</b>	<b>Description</b>
<b>No Connect</b>				
DNC	A1, E1, E5, E6, E7, E12, F2, G3, H1, H4, J1, J2, J3, J4, K1, K2, K3, K4, K5, L1, L2, L3, L4, M1, M2, M3, M4, M5, N1, N2, N3, N4, P1, P2, P3, R1, R2, R16, T1, T15, T16, U18, Y11, Y12, B4, A4, D6	DNC	–	<b>Do Not Connect.</b> The pins listed in this block are for test purposes only and should not be connected (float). Do not connect these pins together.

Broadcom Confidential



## Section 6: Pin Assignments

Ball List by Ball Number

**Table 44: Pin Assignment (Sorted by Ball Number)**

Ball #	Signal Name	Ball #	Signal Name	Ball #	Signal Name	Ball #	Signal Name
A1	DNC	B14	GMII1_RXD6	D7	TXER	E20	GMII0_RXD6
A2	HW_FWDG_EN	B15	GMII1_RXD3	D8	TXD1	F1	TRST
A3	MOSI	B16	GMII1_RXD0	D9	CRS	F2	DNC
A4	DNC	B17	GMII0_TXD0	D10	GMII1_SD	F3	LEDDATA
A5	RXD3	B18	GMII0_TXD3	D11	GMII1_TX_EN	F4	CPU_EEPROM_SEL
A6	RXD0	B19	GMII0_TXD6	D12	GMII1_TX_ER	F5	GIGAO_IFSEL_0
A7	RXDV	B20	GMII0_TX_ER	D13	TBI1_RBC0	F6	VDDC
A8	TXCLK	C1	RvMII_EN	D14	GMII1_RXER	F7	VDDC
A9	TXD2	C2	EEPROM_TYPE_1	D15	GMII1_RXDV	F8	VDDC
A10	MII1_TXC	C3	LEDMODE_1	D16	GMII0_SD	F9	VDDC
A11	GMII1_TXD2	C4	RESET	D17	MII0_TXC	F10	VDDC
A12	GMII1_TXD5	C5	MDIO	D18	TBIO_RBC1	F11	VDDC
A13	GMII1_GTXCLK	C6	RXD2	D19	TBIO_RBC0	F12	VDDC
A14	GMII1_RXD7	C7	RXER	D20	GMII0_RXCLK	F13	VDDC
A15	GMII1_RXD4	C8	TXD0	E1	DNC	F14	VDDC
A16	GMII1_RXD1	C9	COL	E2	LEDCLK	F15	VDDC
A17	GMII1_CRS	C10	GMII1_TXD1	E3	EN_GRX_FLOW	F16	VDDC
A18	GMII0_TXD2	C11	GMII1_TXD4	E4	LEDMODE_2	F17	GMII0_RXD2
A19	GMII0_TXD5	C12	GMII1_TXD7	E5	DNC	F18	GMII0_RXD5
A20	GMII0_TX_EN	C13	TBI1_RBC1	E6	DNC	F19	GMII0_RXD4
B1	PHY_POLL_DIS	C14	GMII1_RXD5	E7	DNC	F20	TD23-
B2	LEDMODE_0	C15	GMII1_RXD2	E8	VDDP	G1	TDI
B3	MISO	C16	GMII1_COL	E9	ENFDXFLOW	G2	TMS
B4	DNC	C17	GMII0_TXD1	E10	ENHDXFLOW	G3	DNC
B5	MDC	C18	GMII0_TXD4	E11	VDDP	G4	GIGA1_IFSEL_1
B6	RXD1	C19	GMII0_TXD7	E12	DNC	G5	VDDC
B7	RXCLK	C20	GMII0_GTXCLK	E13	MDIX_DIS	G6	VDDO2
B8	TXEN	D1	GIGA1_IFSEL_0	E14	VDDC	G7	VDDO2
B9	TXD3	D2	GIGAO_IFSEL_1	E15	VDDC	G8	VDDO2
B10	GMII1_TXD0	D3	EEPROM_TYPE_0	E16	VDDC	G9	VDDO2
B11	GMII1_TXD3	D4	SS	E17	GMII0_RXER	G10	VDDO2
B12	GMII1_TXD6	D5	SCK	E18	GMII0_RXDV	G11	VDDO1
B13	GMII1_RXCLK	D6	DNC	E19	GMII0_RXD7	G12	VDDO1

<b>Ball #</b>	<b>Signal Name</b>	<b>Ball #</b>	<b>Signal Name</b>	<b>Ball #</b>	<b>Signal Name</b>	<b>Ball #</b>	<b>Signal Name</b>
G13	VDDO1	J12	GND	L11	GND	N10	GND
G14	VDDO0	J13	GND	L12	GND	N11	GND
G15	VDDO0	J14	GND	L13	GND	N12	GND
G16	VDDC	J15	VDDO0	L14	GND	N13	GND
G17	GMII0_RXD1	J16	VDDP	L15	AVSS	N14	GND
G18	GMII0_RXD3	J17	GMII0_COL	L16	AVDDL	N15	AVSS
G19	RD21-	J18	TD21-	L17	TD17+	N16	AVDDL
G20	TD23+	J19	RD22-	L18	TD19-	N17	VDDP
H1	DNC	J20	RD23-	L19	RD20-	N18	RD19-
H2	TDO	K1	DNC	L20	TD22-	N19	RD18-
H3	TCK	K2	DNC	M1	DNC	N20	TD20-
H4	DNC	K3	DNC	M2	DNC	P1	DNC
H5	VDDP	K4	DNC	M3	DNC	P2	DNC
H6	VDDO2	K5	DNC	M4	DNC	P3	DNC
H7	GND	K6	VDDO2	M5	DNC	P4	VREGCTL2_5
H8	GND	K7	GND	M6	VDDO2	P5	AVSS
H9	GND	K8	GND	M7	GND	P6	VDDO3
H10	GND	K9	GND	M8	GND	P7	AVSS
H11	GND	K10	GND	M9	GND	P8	AVSS
H12	GND	K11	GND	M10	GND	P9	AVSS
H13	GND	K12	GND	M11	GND	P10	AVSS
H14	GND	K13	GND	M12	GND	P11	AVSS
H15	VDDO0	K14	GND	M13	GND	P12	AVSS
H16	VDDC	K15	AVSS	M14	GND	P13	AVSS
H17	GMII0_RXD0	K16	AVDDL	M15	AVSS	P14	AVSS
H18	TD21+	K17	GMII0_CRS	M16	AVDDL	P15	AVSS
H19	RD21+	K18	TD19+	M17	TD17-	P16	AVDDL
H20	RD23+	K19	RD22+	M18	RD19+	P17	BIASVDD
J1	DNC	K20	TD22+	M19	RD20+	P18	RD17+
J2	DNC	L1	DNC	M20	TD20+	P19	RD18+
J3	DNC	L2	DNC	N1	DNC	P20	TD18+
J4	DNC	L3	DNC	N2	DNC	R1	DNC
J5	VDDC	L4	DNC	N3	DNC	R2	DNC
J6	VDDO2	L5	VDDC	N4	DNC	R3	VREGSENSE2_5
J7	GND	L6	VDDO2	N5	VDDC	R4	VDDO3
J8	GND	L7	GND	N6	VDDO3	R5	AVSS
J9	GND	L8	GND	N7	GND	R6	AVSS
J10	GND	L9	GND	N8	GND	R7	AVSS
J11	GND	L10	GND	N9	GND	R8	AVSS

<b>Ball #</b>	<b>Signal Name</b>	<b>Ball #</b>	<b>Signal Name</b>	<b>Ball #</b>	<b>Signal Name</b>
R9	AVSS	U8	RD5-	W7	TD4+
R10	AVSS	U9	RD5+	W8	TD6-
R11	AVSS	U10	RD8+	W9	TD6+
R12	AVSS	U11	RD8-	W10	RDAC0
R13	AVSS	U12	RD10+	W11	BIASVDD
R14	AVSS	U13	RD10-	W12	TD9+
R15	AVSS	U14	RD12+	W13	TD9-
R16	DNC	U15	RD12-	W14	TD11+
R17	RDAC2	U16	RD14+	W15	TD11-
R18	RD17-	U17	RD14-	W16	RD13-
R19	RD16-	U18	DNC	W17	RD13+
R20	TD18-	U19	XTALVDD	W18	RD15-
T1	DNC	U20	TD16-	W19	RD15+
T2	REGAGND2_5	V1	VREGAVDD2_5	W20	RDAC1
T3	REGAGND1_2	V2	VREGCTL1_2	Y1	RD0+
T4	VREGAVDDIO1_2	V3	TD1+	Y2	RD0-
T5	AVDDL	V4	TD1-	Y3	RD2+
T6	AVDDL	V5	TD3+	Y4	RD2-
T7	AVDDL	V6	TD3-	Y5	RD4+
T8	AVDDL	V7	TD5+	Y6	RD4-
T9	AVDDL	V8	TD5-	Y7	RD6+
T10	AVDDL	V9	RD7-	Y8	RD6-
T11	AVDDL	V10	RD7+	Y9	TD7+
T12	AVDDL	V11	TD8-	Y10	TD7-
T13	AVDDL	V12	TD8+	Y11	DNC
T14	AVDDL	V13	TD10-	Y12	DNC
T15	DNC	V14	TD10+	Y13	RD9-
T16	DNC	V15	TD12-	Y14	RD9+
T17	VDDO2	V16	TD12+	Y15	RD11-
T18	BIASVDD	V17	TD14-	Y16	RD11+
T19	RD16+	V18	TD14+	Y17	TD13+
T20	TD16+	V19	XTALI	Y18	TD13-
U1	VDDO3	V20	XTALO	Y19	TD15+
U2	VREGAVDDIO2_5	W1	VREGSENSE1_2	Y20	TD15-
U3	VREGAVDD1_2	W2	TD0-		
U4	RD1-	W3	TD0+		
U5	RD1+	W4	TD2-		
U6	RD3-	W5	TD2+		
U7	RD3+	W6	TD4-		

## Ball List by Signal Name

**Table 45: Pin Assignment (Sorted by Signal Name)**

<b>Signal Name</b>	<b>Ball #</b>	<b>Signal Name</b>	<b>Ball #</b>	<b>Signal Name</b>	<b>Ball #</b>	<b>Signal Name</b>	<b>Ball #</b>
AVDDL	K16	AVSS	R5	DNC	M3	GMII0_RXD4	F19
AVDDL	L16	AVSS	R6	DNC	M4	GMII0_RXD5	F18
AVDDL	M16	AVSS	R7	DNC	M5	GMII0_RXD6	E20
AVDDL	N16	AVSS	R8	DNC	N1	GMII0_RXD7	E19
AVDDL	P16	AVSS	R9	DNC	N2	GMII0_RXDV	E18
AVDDL	T10	BIASVDD	P17	DNC	N3	GMII0_RXER	E17
AVDDL	T11	BIASVDD	T18	DNC	N4	GMII0_SD	D16
AVDDL	T12	BIASVDD	W11	DNC	P1	GMII0_TX_EN	A20
AVDDL	T13	COL	C9	DNC	P2	GMII0_TX_ER	B20
AVDDL	T14	CPU_EEPROM_SEL	F4	DNC	P3	GMII0_TXD0	B17
AVDDL	T5	CRS	D9	DNC	R1	GMII0_TXD1	C17
AVDDL	T6	DNC	A1	DNC	R16	GMII0_TXD2	A18
AVDDL	T7	DNC	E1	DNC	R2	GMII0_TXD3	B18
AVDDL	T8	DNC	E12	DNC	T1	GMII0_TXD4	C18
AVDDL	T9	DNC	E5	DNC	T15	GMII0_TXD5	A19
AVSS	K15	DNC	E6	DNC	T16	GMII0_TXD6	B19
AVSS	L15	DNC	E7	DNC	U18	GMII0_TXD7	C19
AVSS	M15	DNC	F2	DNC	Y11	GMII1_COL	C16
AVSS	N15	DNC	G3	DNC	Y12	GMII1_CRS	A17
AVSS	P10	DNC	H1	EEPROM_TYPE_0	D3	GMII1_GTXCLK	A13
AVSS	P11	DNC	H4	EEPROM_TYPE_1	C2	GMII1_RXCLK	B13
AVSS	P12	DNC	J1	EN_GRX_FLOW	E3	GMII1_RXD0	B16
AVSS	P13	DNC	J2	ENFDXFLOW	E9	GMII1_RXD1	A16
AVSS	P14	DNC	J3	ENHDXFLOW	E10	GMII1_RXD2	C15
AVSS	P15	DNC	J4	GIGA0_IFSEL_0	F5	GMII1_RXD3	B15
AVSS	P5	DNC	K1	GIGA0_IFSEL_1	D2	GMII1_RXD4	A15
AVSS	P7	DNC	K2	GIGA1_IFSEL_0	D1	GMII1_RXD5	C14
AVSS	P8	DNC	K3	GIGA1_IFSEL_1	G4	GMII1_RXD6	B14
AVSS	P9	DNC	K4	GMII0_COL	J17	GMII1_RXD7	A14
AVSS	R10	DNC	K5	GMII0_CRS	K17	GMII1_RXDV	D15
AVSS	R11	DNC	L1	GMII0_GTXCLK	C20	GMII1_RXER	D14
AVSS	R12	DNC	L2	GMII0_RXCLK	D20	GMII1_SD	D10
AVSS	R13	DNC	L3	GMII0_RXD0	H17	GMII1_TX_EN	D11
AVSS	R14	DNC	L4	GMII0_RXD1	G17	GMII1_TX_ER	D12
AVSS	R15	DNC	M1	GMII0_RXD2	F17	GMII1_TXD0	B10
		DNC	M2	GMII0_RXD3	G18	GMII1_TXD1	C10

<i>Signal Name</i>	<i>Ball #</i>	<i>Signal Name</i>	<i>Ball #</i>	<i>Signal Name</i>	<i>Ball #</i>	<i>Signal Name</i>	<i>Ball #</i>
GMII1_TXD2	A11	GND	M11	RD11+	Y16	RD9-	Y13
GMII1_TXD3	B11	GND	M12	RD12-	U15	RD9+	Y14
GMII1_TXD4	C11	GND	M13	RD12+	U14	RDAC0	W10
GMII1_TXD5	A12	GND	M14	RD13-	W16	RDAC1	W20
GMII1_TXD6	B12	GND	M7	RD13+	W17	RDAC2	R17
GMII1_TXD7	C12	GND	M8	RD14-	U17	REGAGND1_2	T3
GND	H10	GND	M9	RD14+	U16	REGAGND2_5	T2
GND	H11	GND	N10	RD15-	W18	RESET	C4
GND	H12	GND	N11	RD15+	W19	RvMII_EN	C1
GND	H13	GND	N12	RD16-	R19	RXCLK	B7
GND	H14	GND	N13	RD16+	T19	RXD0	A6
GND	H7	GND	N14	RD17-	R18	RXD1	B6
GND	H8	GND	N7	RD17+	P18	RXD2	C6
GND	H9	GND	N8	RD18-	N19	RXD3	A5
GND	J10	GND	N9	RD18+	P19	RXDV	A7
GND	J11	HW_FWDG_EN	A2	RD19-	N18	RXER	C7
GND	J12	LEDCLK	E2	RD19+	M18	SCK	D5
GND	J13	LEDDATA	F3	RD2-	Y4	SS	D4
GND	J14	LEDMODE_0	B2	RD2+	Y3	TBI0_RBC0	D19
GND	J7	LEDMODE_1	C3	RD20-	L19	TBI0_RBC1	D18
GND	J8	LEDMODE_2	E4	RD20+	M19	TBI1_RBC0	D13
GND	J9	MDC	B5	RD21-	G19	TBI1_RBC1	C13
GND	K10	MDIO	C5	RD21+	H19	TCK	H3
GND	K11	MDIX_DIS	E13	RD22-	J19	TD0-	W2
GND	K12	DNC	B4	RD22+	K19	TD0+	W3
GND	K13	DNC	D6	RD23-	J20	TD1-	V4
GND	K14	DNC	A4	RD23+	H20	TD1+	V3
GND	K7	MII0_TXC	D17	RD3-	U6	TD10-	V13
GND	K8	MII1_TXC	A10	RD3+	U7	TD10+	V14
GND	K9	MISO	B3	RD4-	Y6	TD11-	W15
GND	L10	MOSI	A3	RD4+	Y5	TD11+	W14
GND	L11	PHY_POLL_DIS	B1	RD5-	U8	TD12-	V15
GND	L12	RD0-	Y2	RD5+	U9	TD12+	V16
GND	L13	RD0+	Y1	RD6-	Y8	TD13-	Y18
GND	L14	RD1-	U4	RD6+	Y7	TD13+	Y17
GND	L7	RD1+	U5	RD7-	V9	TD14-	V17
GND	L8	RD10-	U13	RD7+	V10	TD14+	V18
GND	L9	RD10+	U12	RD8-	U11	TD15-	Y20
GND	M10	RD11-	Y15	RD8+	U10	TD15+	Y19

<i>Signal Name</i>	<i>Ball #</i>	<i>Signal Name</i>	<i>Ball #</i>	<i>Signal Name</i>	<i>Ball #</i>
TD16-	U20	TXD2	A9	VDDO2	L6
TD16+	T20	TXD3	B9	VDDO2	M6
TD17-	M17	TXEN	B8	VDDO2	T17
TD17+	L17	TXER	D7	VDDO3	N6
TD18-	R20	VDDC	E14	VDDO3	P6
TD18+	P20	VDDC	E15	VDDO3	R4
TD19-	L18	VDDC	E16	VDDO3	U1
TD19+	K18	VDDC	F10	VDDP	E11
TD2-	W4	VDDC	F11	VDDP	E8
TD2+	W5	VDDC	F12	VDDP	H5
TD20-	N20	VDDC	F13	VDDP	J16
TD20+	M20	VDDC	F14	VDDP	N17
TD21-	J18	VDDC	F15	VREGAVDD1_2	U3
TD21+	H18	VDDC	F16	VREGAVDD2_5	V1
TD22-	L20	VDDC	F6	VREGAVDDIO1_2	T4
TD22+	K20	VDDC	F7	VREGAVDDIO2_5	U2
TD23-	F20	VDDC	F8	VREGCTL1_2	V2
TD23+	G20	VDDC	F9	VREGCTL2_5	P4
TD3-	V6	VDDC	G16	VREGSENSE1_2	W1
TD3+	V5	VDDC	G5	VREGSENSE2_5	R3
TD4-	W6	VDDC	H16	XTALI	V19
TD4+	W7	VDDC	J5	XTALO	V20
TD5-	V8	VDDC	L5	XTALVDD	U19
TD5+	V7	VDDC	N5		
TD6-	W8	VDDO0	G14		
TD6+	W9	VDDO0	G15		
TD7-	Y10	VDDO0	H15		
TD7+	Y9	VDDO0	J15		
TD8-	V11	VDDO1	G11		
TD8+	V12	VDDO1	G12		
TD9-	W13	VDDO1	G13		
TD9+	W12	VDDO2	G10		
TDI	G1	VDDO2	G6		
TDO	H2	VDDO2	G7		
TMS	G2	VDDO2	G8		
TRST	F1	VDDO2	G9		
TXCLK	A8	VDDO2	H6		
TXD0	C8	VDDO2	J6		
TXD1	D8	VDDO2	K6		

# Section 7: BCM53242M Ball Locations

## 400-PBGA Ball Location Diagram

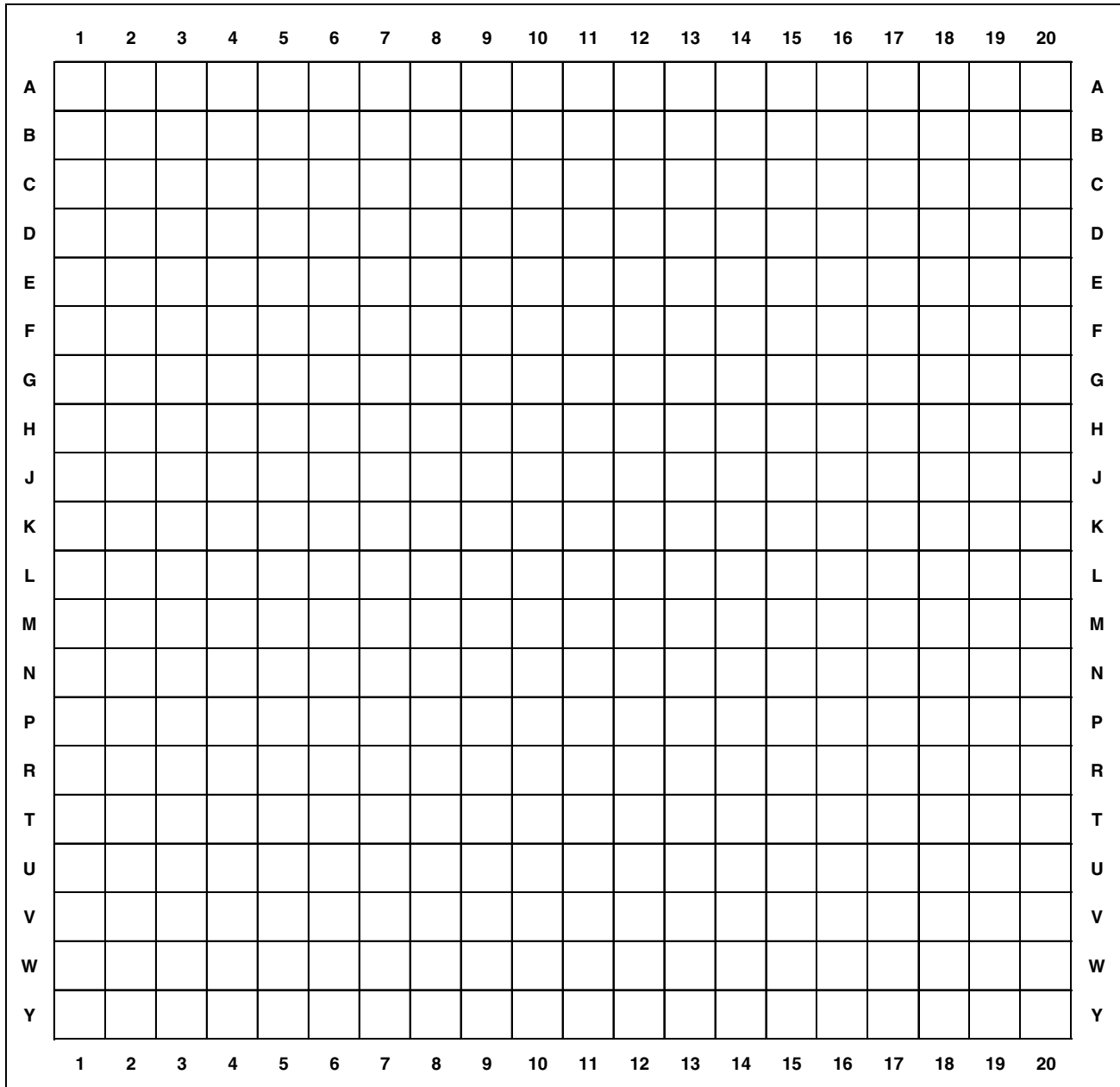

Figure 41: 400-PBGA Ball Location Diagram (Top View)

## Section 8: Register Definitions

### Register Notations

In the register description tables, the following notation in the R/W column is used to describe the ability to read or write:

- R/W = Read or write
- RO = Read only
- LH = Latched high. Clear after read operation
- LL = Latched low. Clear after read operation
- H = Fixed high
- L = Fixed low
- SC = Self clear after read

Reserved bits must be written as the default value and ignored when read.

### Register Definition

The BCM532XX series consists of several devices with differing port configurations. Except as noted in [Table 46](#), all switching features are identical within each of the devices. The register definition described hereunder is in the highest port count configuration. Refer to [Table 46](#) for the valid port configuration and feature difference for the specific device.

**Table 46: Valid Port Map and Feature Difference**

<i>Device</i>	<i>FE Ports</i>	<i>GE Ports</i>	<i>CFP Rules</i>	<i>MAC-Based QoS/VLAN</i>	<i>Protocol-Based QoS/VLAN</i>	<i>QinQ</i>	<i>VLAN Translation</i>
BCM53242M	P0 ~ P23	G0, G1	1K	Y	Y	Y	Y
BCM53242S	P0 ~ P23	G0, G1	512	N	N	N	N
BCM53212M	P0 ~ P15	G0, G1	1K	Y	Y	Y	Y
BCM53212S	P0 ~ P15	G0, G1	512	N	N	N	N
BCM53202M	P0 ~ P7	G0, G1	1K	Y	Y	Y	Y
BCM53202S	P0 ~ P7	G0, G1	512	N	N	N	N
BCM53201M	P0 ~ P4	G0, G1	1K	Y	Y	Y	Y



The BCM53242M's registers set can be accessed through the SPI Port. The register space is organized into pages, each contains a certain set of registers. The following table lists the pages defined in the BCM53242M. In addition to access via the SPI port, registers can be accessed via the MDC/MDIO path via pseudo MII mode. The per-port MII registers are still accessible via the MDC/MDIO path of the external MII, compatible with the BCM53xx device mode.

To access a page, the page register (0xFF) is written with the page value. The registers contained in the page can then be accessed by their address.

**Table 47: Global Page Register Map**

<b>Page</b>	<b>Description</b>
00h	"Page 00h: Control Registers" on page 155.
01h	"Page 01h: Control 1 Registers" on page 174
02h	"Page 02h: Status Registers" on page 186.
03h	"Page 03h: Management Mode Registers" on page 193.
04h	"Page 04h: ARL Control Register" on page 208.
05h	"Page 05h: ARL Access Registers" on page 211.
06h-09h	Reserved
0Ah	"Page 0Ah: Priority Queue Control Registers" on page 229
0Dh	"Page 0Dh: TBI Registers" on page 253
10h	"Page 10h: PHY Info Registers" on page 259
20h	"Page 20h: CFP Registers" on page 260
21h	"Page 21h: CFP Control Registers" on page 271
22h	"Page 22h: CFP UDF Control Registers" on page 276
30h	"Page 30h: QoS Registers" on page 288.
31h	"Page 31h: MAC-Based Aggregation Registers" on page 295
33h	"Page 33h: Port Egress Control Registers" on page 298
34h	"Page 34h: 802.1Q VLAN Registers" on page 300.
40h	"Page 40h: 802.1x Registers" on page 316.
41h	"Page 41h: 802.1x_1 Registers" on page 322
43h	"Page 43h: Rate Control Registers" on page 328
44h	Reserved
45h	"Page 45h: 802.1s Multiple Spanning Tree Registers" on page 334
68h-84h	"Page 68h-84h: Port MIB Registers" on page 336
85h	"Page 85h: Snapshot Port MIB Registers" on page 338
A0h-B7h	"Page A0h-B7h: FE Ports 0-23 MII Registers" on page 340
B8h-D7h	Reserved
D8h-DAh	"Page D8h-DAh: External PHY Registers" on page 353
F0h	SPI Data I/O 0—Table 337: "Global Registers (Maps to All Pages)," on page 355.
F1h	SPI Data I/O 1—Table 337: "Global Registers (Maps to All Pages)," on page 355.
F2h	SPI Data I/O 2—Table 337: "Global Registers (Maps to All Pages)," on page 355.

**Table 47: Global Page Register Map (Cont.)**

<b>Page</b>	<b>Description</b>
F3h	SPI Data I/O 3— <a href="#">Table 337: “Global Registers (Maps to All Pages),” on page 355.</a>
F4h	SPI Data I/O 4— <a href="#">Table 337: “Global Registers (Maps to All Pages),” on page 355.</a>
F5h	SPI Data I/O 5— <a href="#">Table 337: “Global Registers (Maps to All Pages),” on page 355.</a>
F6h	SPI Data I/O 6— <a href="#">Table 337: “Global Registers (Maps to All Pages),” on page 355.</a>
F7h	SPI Data I/O 7–0.
F8h–FDh	Reserved
FEh	<a href="#">“Global Registers” on page 355.</a>
FFh	Page Register

## Page 00h: Control Registers

**Table 48: Control Registers (Page 00h)**

Address	Bits	Register Name
00h	8	"Switch Mode Register (Page 00h/Addr 00h)" on page 156
01h	Reserved	
02h	8	"PHY Scan Control Register (Page 00h/Addr 02h)" on page 156
03h	8	"New Control Register (Page 00h/Addr 03h)" on page 157
05h-1Fh	–	Reserved
20h	8	"Broadcast Forward Map Register (Page 00h/Addr 20h)" on page 158
28h	64	"IPMC Lookup Fail Forward Map Register (Page 00h/Addr 28h)" on page 159
30h	64	"Unicast Lookup Fail Forward Map Register (Page 00h/Addr 30h)" on page 159
38h	64	"Multicast Lookup Fail Forward Map Register (Page 00h/Addr 38h)" on page 160
40h	64	"Protected Port Select Register (Page 00h/Addr 40h)" on page 161
48h	64	"Software Flow Control Registers (Page 00h/Addr 48h)" on page 162
50h	32	"Strap Pins Status Register (Page 00h/Addr 50h)" on page 163
54h-59h	Reserved	
5Ah	16	"LED Control Register (Page 00h/Addr 5Ah)" on page 164
5Ch	16	"LED Function 0 Control Register (Page 00h/Addr 5Ch–5Dh)" on page 166
5Eh	16	"LED Function 1 Control Register (Page 00h/Addr 5Eh–5Fh)" on page 166
60h	64	"LED Function Map Register (Page 00h/Addr 60h–67h)" on page 168
68h	64	"LED Enable Map Register (Page 00h/Addr 68h–6Fh)" on page 169
70h	64	"LED Mode Map 0 Register (Page 00h/Addr 70h–77h)" on page 170
78h	64	"LED Mode Map 1 Register (Page 00h/Addr 78h–7Fh)" on page 171
90h	64	"RX PAUSE PASS Register (Page 00h/Addr 90h–97h)" on page 172
98h	64	"TX PAUSE PASS Register (Page 00h/Addr 98h–9Fh)" on page 173
A0h-EFh	Reserved	
F0h-F7h	–	SPI Data I/O[0:7]
FEh	–	SPI Status
FFh	8	Page Register

## Switch Mode Register (Page 00h/Addr 00h)

**Table 49: Switch Mode Register (Page 00h: Address 00h)**

Bit	Name	R/W	Description	Default
7:6	RSVD	–	Reserved. Write as default. Ignore on read.	10
5:4	IPG	R/W	Programmable Inter-Packet-Gap. For 10/100 speed: <ul style="list-style-type: none"> <li>• 11 = 96-bit time</li> <li>• 10 = 92-bit time</li> <li>• 0x = Reserved</li> </ul>	11
3	NOBLKCD	R/W	When the bit is set, it does not block the carrier detected signal. <ul style="list-style-type: none"> <li>• 1 = Does not block, and txport always defers to CRS.</li> <li>• 0 = Block CD</li> </ul>	0
2	RTRY_LMT_DIS	R/W	Retry Limit Disable 1 = Disable retry limit on all 10/100 ports 0 = Continuously transmit after 15 retry attempts in half duplex collision mode.	1
1	SW_FWDG_EN	R/W	Software Forwarding Enable. <ul style="list-style-type: none"> <li>• SW_FWDG_EN=1: Frame forwarding is enabled.</li> <li>• SW_FWDG_EN=0: Frame forwarding is disabled.</li> </ul> Read from HW_FWDG_EN pin on power-on. Can be overwritten subsequently. For managed switch implementations (BCM53242M mode), the switch should be configured to disable forwarding on power-on, to allow the processor to configure the internal address table and other parameters, before frame forwarding is enabled.	HW_FWDG_EN strap pin state
0	SW_FWDG_MODE	R/W	Software Forwarding Mode. Programmed from the inverse of the HW_FWDG_EN pin at power-on. Can be overwritten subsequently. <ul style="list-style-type: none"> <li>• 1 = Managed Mode.</li> <li>• 0 = Unmanaged Mode.</li> </ul>	inverted HW_FWDG_EN strap pin state

## PHY Scan Control Register (Page 00h/Addr 02h)

**Table 50: PHY Scan Control Register (Page 00h: Address 02h)**

Bit	Name	R/W	Description	Default
7	PHY_START_ADDR	R/W	PHY Scanning Starting Address. <ul style="list-style-type: none"> <li>• 1 = Set to 5'h01</li> <li>• 0 = Set to 5'h00</li> </ul>	0

**Table 50: PHY Scan Control Register (Page 00h: Address 02h)**

Bit	Name	R/W	Description	Default
6:2	RSVD	RO	Reserved. Write default. Ignore on read.	0
1	EN_PHY_SCAN	R/W	<p>Enable Global External PHY Scanning Function</p> <p>Programmed from the inverse of the PHY_POLL_DIS pin at power-on reset. Can be overwritten subsequently.</p> <ul style="list-style-type: none"> <li>When enabled and PHY_START_ADDR = 0, the BCM53242M will poll externally at addresses 18h, 19h and 1Ah to read the PHY status.</li> <li>When enabled and PHY_START_ADDR = 1, the BCM53242M will poll externally at addresses 19h, 1Ah and 1Bh to read the PHY status.</li> <li>1 = Enable PHY scanning</li> <li>0 = Disable PHY scanning</li> </ul>	1 Inverse of PHY_POLL_DIS Strap Pin State
0	EN_INIT_CFG	R/W	Enable.	1

## New Control Register (Page 00h/Addr 03h)

**Table 51: New Control Register (Page 00h: Address 03h)**

Bit	Name	R/W	Description	Default
7:6	MLF_FM_EN	R/W	<p>Multicast Lookup Fail Forward Map Enable.</p> <ul style="list-style-type: none"> <li>00: Any incoming packets with multicast DA not in ARL table are flooded.</li> <li>01: Any incoming packets with multicast DA not in ARL table are forwarded according to the <a href="#">“Multicast Lookup Fail Forward Map Register (Page 00h/Addr 38h)”</a> on page 160.</li> <li>10: IPMC lookup fail packets are forwarded according to <a href="#">“IPMC Lookup Fail Forward Map Register (Page 00h/Addr 28h)”</a> on page 159.</li> <li>11: Reserved.</li> </ul>	0
5	ULF_FM_EN	R/W	<p>Unicast Lookup Fail Forward Map Enable.</p> <p>When set to 1, any incoming packets with unicast DA not in ARL table are forwarded according to the <a href="#">“Unicast Lookup Fail Forward Map Register (Page 00h/Addr 30h)”</a> on page 159.</p>	0
4	CLK25	R/W	<ul style="list-style-type: none"> <li>1 = Enable 25-MHz clock output.</li> <li>0 = Disable 25-MHz clock output.</li> </ul>	1

**Table 51: New Control Register (Page 00h: Address 03h) (Cont.)**

Bit	Name	R/W	Description	Default
3	BCAST_FWD_MAP_EN	R/W	Broadcast Traffic Forward Control <ul style="list-style-type: none"> <li>• 1 = Broadcast packets are forwarded according to “Broadcast Forward Map Register (Page 00h/Addr 20h)” on page 158.</li> <li>• 0 = Broadcast packets are flooded to all ports.</li> </ul>	0
2:1	MAX_RX_LIMIT	RW	Maximum Receive Packet Length Limit (Revision 0 B Silicon only) <ul style="list-style-type: none"> <li>* 00 = 2048 bytes for all packets (Default)</li> <li>* 01 = 1536 bytes for all packets</li> <li>* 10 = 1518 bytes for untagged packets or 1522 bytes for single tagged packets or 1526 bytes for doubled tagged packets</li> <li>* 11 = 2000 bytes for all packets</li> </ul>	
	RSVD	RO	Reserved (Revision A Silicon) Write default. Ignore on read.	0
0	DIS_ECC_CHK	R/W	When set to a 1, disable ECC check.	0

## Broadcast Forward Map Register (Page 00h/Addr 20h)

**Table 52: BCAST Forward Map Register (Page 00h: Address 20h)**

Bit	Name	R/W	Description	Default
63:51	RSVD	RO	Reserved. Write default. Ignore on read	0
50:24	BCST_FWD_MAP[50:24]	R/W	Broadcast Forward Map When BCAST_FWD_MAP_EN = 1 in “New Control Register (Page 00h/Addr 03h)” on page 157. <ul style="list-style-type: none"> <li>• Bit 50 = GigaPort G1</li> <li>• Bit 49 = GigaPort G0</li> <li>• Bit 48 = IMP</li> <li>• Bits 47:24 = 10/100 ports [port 23–port 0]               <ul style="list-style-type: none"> <li>– 1 = Forward enable.</li> <li>– 0 = Forward disable.</li> </ul> </li> </ul>	0
23:0	RSVD	–	Reserved	–

## IPMC Lookup Fail Forward Map Register (Page 00h/Addr 28h)

**Table 53: IPMC Lookup Fail Forward Map Register (Page 00h: Address 28h)**

Bit	Name	R/W	Description	Default
63:51	RSVD	RO	Reserved. Write default. Ignore on read	0
50:24	IPMC_LF_FWD_MAP[50:24]	R/W	IPMC Lookup Fail Forward Map, when MLF_FM_EN = 10 in “ <a href="#">New Control Register (Page 00h/Addr 03h)</a> ” on page 157. <ul style="list-style-type: none"> <li>• Bit 50 = GigaPort G1</li> <li>• Bit 49 = GigaPort G0</li> <li>• Bit 48 = IMP</li> <li>• Bits 47:24 = 10/100 ports [port 23–port 0] <ul style="list-style-type: none"> <li>– 1 = Forward enable.</li> <li>– 0 = Forward disable.</li> </ul> </li> </ul>	0
23:0	RSVD	–	Reserved	0

## Unicast Lookup Fail Forward Map Register (Page 00h/Addr 30h)

**Table 54: UC Lookup Fail Forward Map Register (Page 00h: Address 30h)**

Bit	Name	R/W	Description	Default
63:51	RSVD	RO	Reserved. Write default. Ignore on read	0
50:24	UC_LF_FWD_MAP[50:24]	R/W	Unicast Lookup Fail Forward Map, when ULF_FM_EN = 1 in “ <a href="#">New Control Register (Page 00h/Addr 03h)</a> ” on page 157. <ul style="list-style-type: none"> <li>• Bit 50 = GigaPort G1</li> <li>• Bit 49 = GigaPort G0</li> <li>• Bit 48 = IMP</li> <li>• Bits 47:24 = 10/100 ports [port 23–port 0] <ul style="list-style-type: none"> <li>– 1 = Forward enable</li> <li>– 0 = Forward disable</li> </ul> </li> </ul>	0
23:0	RSVD	–	Reserved	0

## Multicast Lookup Fail Forward Map Register (Page 00h/Addr 38h)

*Table 55: MC Lookup Fail Forward Map Register (Page 00h: Address 38h)*

<i>Bit</i>	<i>Name</i>	<i>R/W</i>	<i>Description</i>	<i>Default</i>
63:51	RSVD	RO	Reserved. Write default. Ignore on read	0
50:24	MC_LF_FWD_MAP[50:24]	R/W	MC Lookup Fail Forward Map, when MLF_FM_EN = 1 in <a href="#">“New Control Register (Page 00h/Addr 03h)”</a> on page 157. <ul style="list-style-type: none"> <li>• Bit 50 = GigaPort G1</li> <li>• Bit 49 = GigaPort G0</li> <li>• Bit 48 = IMP</li> <li>• Bits 47:24 = 10/100 ports [port 23–port 0] <ul style="list-style-type: none"> <li>– 1 = Forward enable.</li> <li>– 0 = Forward disable.</li> </ul> </li> </ul>	0
23:0	RSVD	–	Reserved	0



## Protected Port Select Register (Page 00h/Addr 40h)

Table 56: Protected Port Select Register (Page 00h: Address 40h)

Bit	Name	R/W	Description	Default
63:51	RSVD	RO	Reserved. Write default. Ignore on read	0
50:24	PROT_SEL[50:24]	R/W	Protected Port Select Map <ul style="list-style-type: none"> <li>• Bit 50 = GigaPort G1</li> <li>• Bit 49 = GigaPort G0</li> <li>• Bit 48 = IMP</li> <li>• Bits 47:24 = 10/100 ports [port 23–port 0]</li> </ul> Set the assigned Protected port to 1. <b>Example:</b> If port 0 is assigned as the protected port, set to 51'h00_0000_0100_0000. <b>Note:</b> The management port could not be configured as protected port.	0
23:0	RSVD	RO	Reserved	0

## Software Flow Control Registers (Page 00h/Addr 48h)

*Table 57: Software Flow Control Register (Page 00h: Address 48h)*

<b>Bit</b>	<b>Name</b>	<b>R/W</b>	<b>Description</b>	<b>Default</b>
63	SW_FLOW_CON_EN	R/W	Software Flow Control Override Enable. Any change to the SW_FLOW_CON state directly affects the <a href="#">“Pause Status Summary Register (Page 02h/Addr 30h–37h)”</a> on page 193.	0
62	RSVD	–	Reserved.	0
61:54	RSVD	RO	Reserved. Write default. Ignore on read.	0
53:24	SW_FLOW_CON	R/W	Per port software override full-duplex/half-duplex flow control. <ul style="list-style-type: none"> <li>• Bit 53 for giga TX port G1.</li> <li>• Bit 52 for giga RX port G1.</li> <li>• Bit 51 for giga TX port G0.</li> <li>• Bit 50 for giga RX port G0.</li> <li>• Bit 49 for IMP TX port.</li> <li>• Bit 48 for IMP RX port.</li> <li>• Bits 47:24 = 10/100 ports [port 23–port 0] <ul style="list-style-type: none"> <li>– 1 = Enable</li> <li>– 0 = Disable</li> </ul> </li> </ul>	3F-FFFF-FF
23:0	RSVD	–	Reserved	0

## Strap Pins Status Register (Page 00h/Addr 50h)

Table 58: Strap Pins Status Register (Page 00h: Address 50h)

Bit	Name	R/W	Description	Default
31:29	RSVD	RO	Reserved	0
28	WRALLPHY	RO	Allow update to all PHYs at the same time.	0
27	RSVD	RO	Reserved. Write default. Ignore on read.	0
26:22	RSVD	RO	Reserved	0
21	RvMII_EN	RO	<ul style="list-style-type: none"> <li>1 = Reverse MII mode for MII port is enabled</li> <li>0 = Regular MII mode for MII port is enabled</li> </ul>	0
20	RSVD	RO	Reserved	0
19:18	GIGA1_IFSEL	RO	<ul style="list-style-type: none"> <li>00 = RGMII</li> <li>01 = TBI</li> <li>10 = GMII</li> <li>11 = MII</li> </ul>	00
17:16	GIGA0_IFSEL	RO	<ul style="list-style-type: none"> <li>00 = RGMII</li> <li>01 = TBI</li> <li>10 = GMII</li> <li>11 = MII</li> </ul>	00
15	CPU_EEPROM_SEL	RO	<ul style="list-style-type: none"> <li>1: SPI interface is enabled to CPU port</li> <li>0: Disables SPI interface and enables EEPROM interface</li> </ul>	1
14	PHY_POLL_DIS	RO	<ul style="list-style-type: none"> <li>1 = Disable external EPHY/EGPHY polling</li> <li>0 = Enable external EPHY/EGPHY polling</li> </ul>	0
13:12	RSVD	RO	Reserved	0
11	BIST_CLR_RAM	RO	<ul style="list-style-type: none"> <li>0 = Select Memory Clear function</li> <li>1 = Select BIST function</li> </ul>	1
10	SKIP_SRAM_BIST		Disable BIST/Memory clear function	0
9	MDIX_DIS	RO	Disable PHY MDIX Function	0
8:6	LEDMODE	RO	LEDMODE[2:0].	100
5	EN_GRX_FLOW	RO	Full-duplex GigaPort RX Flow Control Enable	1
4	HW_FWDG_EN	RO	<ul style="list-style-type: none"> <li>1 = Forwarding process enable.</li> <li>0 = Turn off forwarding process.</li> </ul> Default is assertion for unmanaged switch.	1
3	RSVD	RO	Reserved	0
2	SYSFREQ	RO	System Clock Status <ul style="list-style-type: none"> <li>0 = 100 MHz</li> <li>1 = 111 MHz</li> </ul>	0
1	ENHDXFLOW	RO	Half-duplex port Flow Control Enable.	1
0	ENFDXFLOW	RO	Full-duplex port Flow Control Enable and GigaPort TX Flow Control Enable.	1

## LED Control Register (Page 00h/Addr 5Ah)

Table 59: LED Control Register (Page 00h: Address 5Ah)

Bit	Name	R/W	Description	Default
15:11	RSVD	R/W	Reserved Write as default. Ignore on read.	0
10	EN_Alt_SEQ	R/W	New Bit Stream Enable <ul style="list-style-type: none"> <li>• 0 = Keep original LED Function Map 0/1 bit sequence</li> <li>• 1 = Enable alternate LED bit sequence for both LED Function Map 0/1 as follows:               <ul style="list-style-type: none"> <li>– 15: reserved</li> <li>– 14: reserved</li> <li>– 13: 1G/ACT</li> <li>– 12: 10/100M/ACT</li> <li>– 11: 100M/ACT</li> <li>– 10: 10M/ACT</li> <li>– 9: SPD10M</li> <li>– 8: LNK/ACT</li> <li>– 7: DPX/COL</li> <li>– 6: LNK</li> <li>– 5: ACT</li> <li>– 4: DPX</li> <li>– 3: COL</li> <li>– 2: SPD100M</li> <li>– 1: SPD1G</li> <li>– 0: reserved</li> </ul> </li> </ul>	1
9	ACT Blink Rate	R/W	Change Blinking Rate for Different Link Speed. When set to <b>1</b> , changes the blinking rate for: <ul style="list-style-type: none"> <li>• 10M = LED Frequency/4</li> <li>• 100M = LED Frequency/2</li> <li>• 1G = LED Frequency/1</li> </ul>	0
8	LED Bit Stream Order	R/W	Bit Stream from Low Port Number First. When set to <b>1</b> , enables LED bit stream from the low port number to be shifted out first.	1
7	LED_EN	R/W	LED Function Enable. Program from HW_FWDG_EN pin on power-on. Can be overwritten subsequently. Default is assertion for unmanaged switch. <ul style="list-style-type: none"> <li>• 1 = Enable LED function</li> <li>• 0 = Disable LED function</li> </ul>	HW_FWDG_EN pin
6	RSVD	R/W	Reserved Write as default. Ignore on read.	0
5	LED_PSCAN_EN	R/W	Write to enable port scan during POST period.	0

**Table 59: LED Control Register (Page 00h: Address 5Ah)**

<b>Bit</b>	<b>Name</b>	<b>R/W</b>	<b>Description</b>	<b>Default</b>
4:3	RSVD	R/W	Reserved Write as default. Ignore on read.	0
2:0	LED_RFS_STOP	R/W	LED Flashing Rate Control <ul style="list-style-type: none"> <li>• 111 : 80 ms/6 Hz.</li> <li>• 110 : 70 ms/7 Hz.</li> <li>• 101 : 60 ms/8 Hz.</li> <li>• 100 : 50 ms/10 Hz.</li> <li>• 011 : 40 ms/12 Hz. (Default)</li> <li>• 010 : 30 ms/16 Hz.</li> <li>• 001 : 20 ms/25 Hz.</li> <li>• 000 : Invalid.</li> </ul>	0x03

Broadcom Confidential

## LED Function 0 Control Register (Page 00h/Addr 5Ch–5Dh)

Table 60: LED Function 0 Control Register (Page 00h: Address 5Ch–5Dh)

Bit	Name	R/W	Description	Default
15:0	LED_FUNC 0	R/W	LED Function 0 Control	LEDMODE[2:0] strap pin state
			15: RSVD	
			14: RSVD	
			13: 1G/ACT	
			12: 10/100/ACT	
			11: 100M/ACT	
			10: 10M/ACT	
			9: SPD 1G	
			8: SPD 100M	
			7: SPD 10M	
			6: DPX/COL	
			5: LNK/ACT	
			4: COL	
			3: ACT	
			2: DPLX	
			1: LNK	
			0: RSVD	
			LEDMODE [000] = 0x0114	
			LEDMODE [001] = 0x0110	
			LEDMODE [010] = 0x0074	
			LEDMODE [011] = 0x0C80	
			LEDMODE [100] = 0x011C (default)	
			LEDMODE [101] = 0x0118	
			LEDMODE [110] = 0x0C00	
			LEDMODE [111] = 0x0184	

## LED Function 1 Control Register (Page 00h/Addr 5Eh–5Fh)

**Table 61: LED Function 1 Control Register (Page 00h: Address 5Eh–5Fh)**

<b>Bit</b>	<b>Name</b>	<b>R/W</b>	<b>Description</b>	<b>Default</b>
15:0	LED_FUNC 1	R/W	LED Function 1 Control 15: RSVD 14: RSVD 13: 1G/ACT 12: 10/100/ACT 11: 100M/ACT 10: 10M/ACT 9: SPD 1G 8: SPD 100M 7: SPD 10M 6: DPX/COL 5: LNK/ACT 4: COL 3: ACT 2: DPLX 1: LNK 0: RSVD LEDMODE [000] = 0x0116 LEDMODE [001] = 0x0110 LEDMODE [010] = 0x0076 LEDMODE [011] = 0x3080 LEDMODE [100] = 0x011E (default) LEDMODE [101] = 0x0118 LEDMODE [110] = 0x3000 LEDMODE [111] = 0x0186	LEDMODE[2:0] strap pin state

## LED Function Map Register (Page 00h/Addr 60h–67h)

*Table 62: LED Function Map Register (Page 00h: Address 60h–67h)*

<b>Bit</b>	<b>Name</b>	<b>R/W</b>	<b>Description</b>	<b>Default</b>
63:51	RSVD	RO	Reserved Write default. Ignore on read	0
50:24	LED_FUNC_MAP	R/W	Per Port LED Function Select Bit <ul style="list-style-type: none"> <li>• Bit 50 = GigaPort G1</li> <li>• Bit 49 = GigaPort G0</li> <li>• Bit 48 = IMP</li> <li>• Bits 47:24 = 10/100 ports [port 23–port 0]               <ul style="list-style-type: none"> <li>– 1 = Select Function 1</li> <li>– 0 = Select Function 0</li> </ul> </li> </ul>	6-FFFF-FF
23:0	RSVD	RO	Reserved	0



## LED Enable Map Register (Page 00h/Addr 68h–6Fh)

*Table 63: LED Enable Map Register (Page 00h: Address 68h–6Fh)*

<b>Bit</b>	<b>Name</b>	<b>R/W</b>	<b>Description</b>	<b>Default</b>
63:51	RSVD	RO	Reserved Write default. Ignore on read	0
50:24	LED_EN_MAP	R/W	Per Port LED Function Enable Bit <ul style="list-style-type: none"> <li>• Bit 50 = GigaPort G1</li> <li>• Bit 49 = GigaPort G0</li> <li>• Bit 48 = IMP</li> <li>• Bits 47:24 = 10/100 ports [port 23–port 0]               <ul style="list-style-type: none"> <li>– 1 = Enable Function</li> <li>– 0 = Disable Function</li> </ul> </li> </ul>	6-FFFF-FF
23:0	RSVD	RO	Reserved	0

## LED Mode Map 0 Register (Page 00h/Addr 70h–77h)

Table 64: LED Mode Map 0 Register (Page 00h: Address 70h–77h)

Bit	Name	R/W	Description	Default
63:51	RSVD	RO	Reserved Write default. Ignore on read	0
50:24	LED_MODE_MAP 0	R/W	Per port LED output control <ul style="list-style-type: none"> <li>• Bit 50 = GigaPort G1</li> <li>• Bit 49 = GigaPort G0</li> <li>• Bit 48 = IMP</li> <li>• Bits 47:24 = 10/100 ports [port 23–port 0]</li> </ul> LED_Mode_Map 0 is used in conjunction with LED_Mode_Map 1 to determine the LED output. <ul style="list-style-type: none"> <li>• [LED_Mode_Map 1, LED_Mode_Map 0] = 11: Auto.</li> <li>• [LED_Mode_Map 1, LED_Mode_Map 0] = 10: Blink.</li> <li>• [LED_Mode_Map 1, LED_Mode_Map 0] = 01: On.</li> <li>• [LED_Mode_Map 1, LED_Mode_Map 0] = 00: Off.</li> </ul>	7-FFFF-FF
23:0	RSVD	RO	Reserved	0

## LED Mode Map 1 Register (Page 00h/Addr 78h–7Fh)

*Table 65: LED Mode Map 1 Register (Page 00h: Address 78h–7Fh)*

<b>Bit</b>	<b>Name</b>	<b>R/W</b>	<b>Description</b>	<b>Default</b>
63:51	RSVD	RO	Reserved Write default. Ignore on read	0
50:24	LED_MODE_MAP 1	R/W	Per port LED output Control <ul style="list-style-type: none"> <li>• Bit 50 = GigaPort G1</li> <li>• Bit 49 = GigaPort G0</li> <li>• Bit 48 = IMP</li> <li>• Bits 47:24 = 10/100 ports [port 23–port 0]</li> </ul> LED_Mode_Map 1 is used in conjunction with LED_Mode_Map 0 to determine the LED output. <ul style="list-style-type: none"> <li>• [LED_Mode_Map 1, LED_Mode_Map 0] = 11: Auto.</li> <li>• [LED_Mode_Map 1, LED_Mode_Map 0] = 10: Blink.</li> <li>• [LED_Mode_Map 1, LED_Mode_Map 0] = 01: On.</li> <li>• [LED_Mode_Map 1, LED_Mode_Map 0] = 00: Off.</li> </ul>	7-FFFF-FF
23:0	RSVD	RO	Reserved	0

## RX PAUSE PASS Register (Page 00h/Addr 90h–97h)

*Table 66: RX Pause Pass Register (Page 00h: Address 90h–97h)*

<b>Bit</b>	<b>Name</b>	<b>R/W</b>	<b>Description</b>	<b>Default</b>
63:51	RSVD	RO	Reserved Write default. Ignore on read	0
50:24	IGNORE_RX_PAUSE	R/W	Per port RX Pause Control <ul style="list-style-type: none"> <li>• Bit 50 = GigaPort G1</li> <li>• Bit 49 = GigaPort G0</li> <li>• Bit 48 = IMP</li> <li>• Bits 47:24 = 10/100 ports [port 23–port 0]               <ul style="list-style-type: none"> <li>– 1 = Ignore incoming 802.3x pause frames.</li> <li>– 0 = Comply with 802.3x pause frame control.</li> </ul> </li> </ul>	0
23:0	RSVD	RO	Reserved	0

## TX PAUSE PASS Register (Page 00h/Addr 98h–9Fh)

*Table 67: TX Pause Pass Register (Page 00h: Address 98h–9Fh)*

Bit	Name	R/W	Description	Default
63:51	RSVD	RO	Reserved Write default. Ignore on read	0
50:24	IGNORE_TX_PAUSE	R/W	Per port TX Pause Control <ul style="list-style-type: none"> <li>• Bit 50 = GigaPort G1</li> <li>• Bit 49 = GigaPort G0</li> <li>• Bit 48 = IMP</li> <li>• Bits 47:24 = 10/100 ports [port 23–port 0]               <ul style="list-style-type: none"> <li>– 1 = Do not transmit 802.3x pause frames.</li> <li>– 0 = Comply with 802.3x pause frame control.</li> </ul> </li> </ul>	0
23:0	RSVD	RO	Reserved	0

## TCAM BIST Control Register (Page 00h/Addr B8h)

*Table 68: MDIO Base Address Register (Page 00h: Address B8h)*

Bit	Name	R/W	Description	Default
7	TCAM_BIST_DONE	RO	TCAM BIST Done This bit is self-cleared when TCAM_BIST_EN = 0	0
6:1	RSVD	RO	Reserved Write default. Ignore on read	0
4:0	TCAM_BIST_EN	R/W	TCAM BIST Enable Enable this bit to read the TCAM BIST status. This bit must be cleared after a valid read of TCAM_BIST_DONE	0

## Configuration ID Register (Page 00h/Addr EEh)

*Table 69: Configuration ID Register (Page 00h/Addr EEh)*

Bit	Name	R/W	Description	Default
15:5	RSVD	RO	Reserved	0
4:0	CONF_ID	RO	Configuration ID	0x0F

## Page 01h: Control 1 Registers

**Table 70: Control 1 Registers (Page 01h)**

Address	Bits	Register Name
00h	8	"GigaPort G0 RGMII Timing Delay Register (Page 01h/Addr 00h)" on page 175.
01h	8	"GigaPort G1 RGMII Timing Delay Register (Page 01h/Addr 01h)" on page 175
02h	8	"GigaPort G0 RGMII Control Register (Page 01h/Addr 02h)" on page 176
03h	8	"GigaPort G1 RGMII Control Register (Page 01h/Addr 03h)" on page 176
04h-27h		–
28h-3Fh	8	"MII Port 0–23 State Override Registers (Page 01h/Addr 28h–3Fh)" on page 176
40h-42h	8	"GigaPort State Override Registers (Page 01h/Addr 41-42h)" on page 178
43h-67h	Reserved	–
68h	8	"IMP Port PHY Scan Result Registers (Page 01H/Addr 68h)" on page 179
69h-70h	8	"G0–G1 GigaPorts PHY Scan Result Registers (Page 01h/Addr 69h–70h)" on page 180
71h-87h	Reserved	–
88h-9Fh	8	"10/100 Ports 0–23 Control Registers (Page 01h/Addr 88h–9Fh)" on page 181
A0h	8	"IMP Port Control Register (Page 01h/Addr A0h)" on page 183
A1h-A2h	8	"GigaPorts G0-G1 Control Registers (Page 01h/Addr A1h–A2h)" on page 184
A3h-AFh	Reserved	–
B0h	8	"Status Control Register (Page 01h/Addr B0h)" on page 185
B1h-EFh	Reserved	–
F0h-F7h	–	SPI Data I/O[0:7]
F8h-FDh	Reserved	
FEh	–	SPI Status
FFh	8	Page Register

## GigaPort G0 RGMII Timing Delay Register (Page 01h/Addr 00h)

**Table 71: GigaPort G0 RGMII Timing Delay Register (Page 01h: Address 00h)**

Bit	Name	R/W	Description	Default
7	DLY_EN	R/W	Delay Enable When set, it affects DLY_CLK and DLY_ADDR	0
6:4	DLY_CLK	R/W	Clock Delay Selection <ul style="list-style-type: none"> <li>• 110 = -1.0x</li> <li>• 111 = -0.5x</li> <li>• 000 = 0.0x</li> <li>• 001 = +0.5x</li> <li>• 010 = +1.0x</li> </ul>	0
3:0	DLY_ADDR	R/W	Delay Timing Selection <ul style="list-style-type: none"> <li>• 0111: clk_gtxt = 1</li> <li>• 1000: clk_gtxg = 1</li> <li>• 1001: clk_gtxr = 1</li> <li>• 1010: clk_rxg = 1</li> <li>• 1011: clk_rxr = 1</li> <li>• 1100: clk_rbco = 1</li> <li>• 1101: clk_rbcl = 1</li> </ul>	0

## GigaPort G1 RGMII Timing Delay Register (Page 01h/Addr 01h)

**Table 72: GigaPort G1 RGMII Timing Delay Register (Page 01h: Address 01h)**

Bit	Name	R/W	Description	Default
7	DLY_EN	R/W	Delay Enable When set, it affects DLY_CLK and DLY_ADDR	0
6:4	DLY_CLK	R/W	Clock Delay Selection <ul style="list-style-type: none"> <li>• 110 = -1.0x</li> <li>• 111 = -0.5x</li> <li>• 000 = 0.0x</li> <li>• 001 = +0.5x</li> <li>• 010 = +1.0x</li> </ul>	0
3:0	DLY_ADDR	R/W	Delay Timing Selection <ul style="list-style-type: none"> <li>• 0111: clk_gtxt = 1</li> <li>• 1000: clk_gtxg = 1</li> <li>• 1001: clk_gtxr = 1</li> <li>• 1010: clk_rxg = 1</li> <li>• 1011: clk_rxr = 1</li> <li>• 1100: clk_rbco = 1</li> <li>• 1101: clk_rbcl = 1</li> </ul>	0

## GigaPort G0 RGMII Control Register (Page 01h/Addr 02h)

Table 73: GigaPort G0 RGMII Control Register (Page 01h: Address 02h)

Bit	Name	R/W	Description	Default
7:2	RSVD	R/W	Reserved. Write as default. Ignore on read.	0
1	RGMII_RX2ns_DLY	R/W	<ul style="list-style-type: none"> <li>1 = Enables RGMII RX 2-ns Delay Mode.</li> <li>0 = Disables RGMII RX 2-ns Delay Mode.</li> </ul>	0
0	RSVD	R/W	Reserved. Write as default. Ignore on read.	0

## GigaPort G1 RGMII Control Register (Page 01h/Addr 03h)

Table 74: GigaPort G1 RGMII Control Register (Page 01h: Address 03h)

Bit	Name	R/W	Description	Default
7:2	RSVD	R/W	Reserved. Write as default. Ignore on read.	0
1	RGMII_RX2ns_DLY	R/W	<ul style="list-style-type: none"> <li>1 = Enables RGMII RX 2-ns Delay Mode.</li> <li>0 = Disables RGMII RX 2-ns Delay Mode.</li> </ul>	0
0	RSVD	R/W	Reserved. Write as default. Ignore on read.	0

## MII Port 0–23 State Override Registers (Page 01h/Addr 28h–3Fh)

Table 75: MII Port 0–23 State Override Registers (Page 01h/Addr 28h–3Fh)

Address	Bits	Register Name
28h	8	Port 0 (see “MII Port State Override Register” on page 177)
29h	8	Port 1 (see “MII Port State Override Register” on page 177)
2Ah	8	Port 2 (see “MII Port State Override Register” on page 177)
2Bh	8	Port 3 (see “MII Port State Override Register” on page 177)
2Ch	8	Port 4 (see “MII Port State Override Register” on page 177)
2Dh	8	Port 5 (see “MII Port State Override Register” on page 177)
2Eh	8	Port 6 (see “MII Port State Override Register” on page 177)
2Fh	8	Port 7 (see “MII Port State Override Register” on page 177)
30h	8	Port 8 (see “MII Port State Override Register” on page 177)
31h	8	Port 9 (see “MII Port State Override Register” on page 177)
32h	8	Port 10 (see “MII Port State Override Register” on page 177)
33h	8	Port 11 (see “MII Port State Override Register” on page 177)
34h	8	Port 12 (see “MII Port State Override Register” on page 177)



Address	Bits	Register Name
35h	8	Port 13 (see “MII Port State Override Register” on page 177)
36h	8	Port 14 (see “MII Port State Override Register” on page 177)
37h	8	Port 15 (see “MII Port State Override Register” on page 177)
38h	8	Port 16 (see “MII Port State Override Register” on page 177)
39h	8	Port 17 (see “MII Port State Override Register” on page 177)
3Ah	8	Port 18 (see “MII Port State Override Register” on page 177)
3Bh	8	Port 19 (see “MII Port State Override Register” on page 177)
3Ch	8	Port 20 (see “MII Port State Override Register” on page 177)
3Dh	8	Port 21 (see “MII Port State Override Register” on page 177)
3Eh	8	Port 22 (see “MII Port State Override Register” on page 177)
3Fh	8	Port 23 (see “MII Port State Override Register” on page 177)

## MII Port State Override Register

**Table 76: MII Port State Override Register**

Bit	Name	R/W	Description	Default
7	RSVD	–	Reserved	1
6	MII_SW_OR	R/W	MII Software Override. <ul style="list-style-type: none"> <li>0 = Use internal MII hardware pin status.</li> <li>1 = Use contents of this register.</li> </ul>	0
5	SW_FC_En	R/W	Software Flow Control Enable.	0
4:3	RSVD	RO	Reserved Write default. Ignore on read	0
2	SPEED	R/W	Software Port Speed Setting. <ul style="list-style-type: none"> <li>1 = 100 Mbps.</li> <li>0 = 10 Mbps.</li> </ul>	1
1	DPLX	R/W	Software Duplex Mode Setting. <ul style="list-style-type: none"> <li>1 = Full-duplex</li> <li>0 = Half-duplex</li> </ul>	1
0	LINK	R/W	Link State. <ul style="list-style-type: none"> <li>1 = Link pass (up).</li> <li>0 = Link fail.</li> </ul>	1

## IMP/MII Port State Override Registers (Page 01h/Addr 40h)

**Table 77: IMP Port State Override Registers (Page 01h/Addr 40h)**

Bit	Name	R/W	Description	Default
7	PHY_Scan Enable	R/W	PHY Scan Control on IMP(MII) port: <ul style="list-style-type: none"> <li>0 = Use MII Software Override</li> <li>1 = PHY scan enabled.</li> </ul>	1
6	MII_SW_OR	R/W	MII Software Override: <ul style="list-style-type: none"> <li>0 = Use MII hardware pin status</li> <li>1 = Use contents of this register</li> </ul>	0
5	SW_FC_En	R/W	Software Flow Control Enable	0
4:3	RSVD	RO	Reserved Write default. Ignore on read	0
2	SPEED	R/W	Software Port Speed Setting: <ul style="list-style-type: none"> <li>1 = 100 Mbps</li> <li>0 = 10 Mbps.</li> </ul>	1
1	FDX	R/W	Full-duplex: <ul style="list-style-type: none"> <li>1 = Full-duplex</li> <li>0 = Half-duplex</li> </ul>	1
0	LINK	R/W	Link State. <ul style="list-style-type: none"> <li>1 = Link pass (up)</li> <li>0 = Link fail</li> </ul>	1

## GigaPort State Override Registers (Page 01h/Addr 41-42h)

**Table 78: GigaPort State Override Registers (Page 01h/Addr 41-42h)**

Address	Bits	Register Name
41h	8	GE port 0 (see <a href="#">Table 79: "MII GigaPort State Override Registers," on page 178</a> )
42h	8	GE port 1 (see <a href="#">Table 79: "MII GigaPort State Override Registers," on page 178</a> )

**Table 79: MII GigaPort State Override Registers**

Bit	Name	R/W	Description	Default
7	GPHY_Scan Enable	R/W	Allows per port control for the BCM53242M to scan the external GPHY.	1
6	MII_SW_OR	R/W	MII Software Override. <ul style="list-style-type: none"> <li>0 = Use GMII hardware pin status.</li> <li>1 = Use contents of this register.</li> </ul>	0

**Table 79: MII GigaPort State Override Registers (Cont.)**

<b>Bit</b>	<b>Name</b>	<b>R/W</b>	<b>Description</b>	<b>Default</b>
5	TX Flow Control	R/W	Software Tx Flow Control Enable. Link Partner Flow Control Capability. <ul style="list-style-type: none"> <li>• 0 = Not PAUSE capable.</li> <li>• 1 = PAUSE capable.</li> </ul>	0
4	RX Flow Control	R/W	Software Rx Flow Control Enable. Link Partner Flow Control Capability. <ul style="list-style-type: none"> <li>• 0 = Not PAUSE capable.</li> <li>• 1 = PAUSE capable.</li> </ul>	0
3:2	SPEED	R/W	Speed. <ul style="list-style-type: none"> <li>• 10 = 1000 Mbps.</li> <li>• 01 = 100 Mbps.</li> <li>• 00 = 10 Mbps.</li> </ul>	10
1	FDX	R/W	Full-duplex. <ul style="list-style-type: none"> <li>• 1 = Full-duplex.</li> <li>• 0 = Half-duplex.</li> </ul>	1
0	LINK	R/W	Link State. <ul style="list-style-type: none"> <li>• 1 = Link pass.</li> <li>• 0 = Link fail.</li> </ul>	1

## IMP Port PHY Scan Result Registers (Page 01H/Addr 68h)

**Table 80: IMP Port PHY Scan Result Registers (Page 01H/Addr 68h)**

<b>Bit</b>	<b>Name</b>	<b>R/W</b>	<b>Description</b>	<b>Default</b>
7	RSVD	RO	Reserved Write default. Ignore on read	0
6	TIMEOUT	RO	PHY Register Scan Timeout Error	0
5	Flow Control	RO	Software Flow Control Enable Link Partner Flow Control Capability <ul style="list-style-type: none"> <li>• 0 = Not PAUSE capable</li> <li>• 1 = PAUSE capable</li> </ul>	0
4:3	RSVD	RO	Reserved Write default. Ignore on read	0
2	SPEED	RO	Speed status <ul style="list-style-type: none"> <li>• 1 = 100 Mbps</li> <li>• 0 = 10 Mbps</li> </ul>	0
1	FDX	RO	Duplex status <ul style="list-style-type: none"> <li>• 1 = Full-duplex</li> <li>• 0 = Half-duplex</li> </ul>	0

**Table 80: IMP Port PHY Scan Result Registers (Page 01H/Addr 68h)**

Bit	Name	R/W	Description	Default
0	LINK	RO	Link status <ul style="list-style-type: none"> <li>• 1 = Link pass</li> <li>• 0 = Link fail</li> </ul>	0

## G0–G1 GigaPorts PHY Scan Result Registers (Page 01h/Addr 69h–70h)

**Table 81: G0–G1 GigaPorts PHY Scan Result Registers (Page 01h/Addr 69h–70h)**

Address	Bits	Register Name
69h	8	GE port 0 (see <a href="#">Table 82: “GigaPorts PHY Scan Result Registers,” on page 180</a> )
70h	8	GE port 1 (see <a href="#">Table 82: “GigaPorts PHY Scan Result Registers,” on page 180</a> )

**Table 82: GigaPorts PHY Scan Result Registers**

Bit	Name	R/W	Description	Default
7	RSVD	RO	Reserved Write default. Ignore on read	0
6	TIMEOUT	RO	PHY Register Scan Timeout Error	0
5	TX Flow Control	RO	Software Tx Flow Control Enable. Link Partner Flow Control Capability. <ul style="list-style-type: none"> <li>• 0 = Not PAUSE capable.</li> <li>• 1 = PAUSE capable.</li> </ul>	0
4	RX Flow Control	RO	Software Rx Flow Control Enable. Link Partner Flow Control Capability. <ul style="list-style-type: none"> <li>• 0 = Not PAUSE capable.</li> <li>• 1 = PAUSE capable.</li> </ul>	0
3:2	SPEED	RO	Speed Status. <ul style="list-style-type: none"> <li>• 10 = 1000 Mbps.</li> <li>• 01 = 100 Mbps.</li> <li>• 00 = 10 Mbps.</li> </ul>	0
1	FDX	RO	Duplex Status. <ul style="list-style-type: none"> <li>• 1 = Full-duplex.</li> <li>• 0 = Half-duplex.</li> </ul>	0
0	LINK	RO	Link Status. <ul style="list-style-type: none"> <li>• 1 = Link pass.</li> <li>• 0 = Link fail.</li> </ul>	0

## 10/100 Ports 0–23 Control Registers (Page 01h/Addr 88h–9Fh)

**Table 83: 10/100 Ports 0-23 Control Registers (Page 01h/Addr 88h–9Fh)**

Address	Bits	Register Name
88h	8	Port 0 (see <a href="#">Table 84: “10/100 Ports Control Registers,” on page 182</a> )
89h	8	Port 1 (see <a href="#">Table 84: “10/100 Ports Control Registers,” on page 182</a> )
8Ah	8	Port 2 (see <a href="#">Table 84: “10/100 Ports Control Registers,” on page 182</a> )
8Bh	8	Port 3 (see <a href="#">Table 84: “10/100 Ports Control Registers,” on page 182</a> )
8Ch	8	Port 4 (see <a href="#">Table 84: “10/100 Ports Control Registers,” on page 182</a> )
8Dh	8	Port 5 (see <a href="#">Table 84: “10/100 Ports Control Registers,” on page 182</a> )
8Eh	8	Port 6 (see <a href="#">Table 84: “10/100 Ports Control Registers,” on page 182</a> )
8Fh	8	Port 7 (see <a href="#">Table 84: “10/100 Ports Control Registers,” on page 182</a> )
90h	8	Port 8 (see <a href="#">Table 84: “10/100 Ports Control Registers,” on page 182</a> )
91h	8	Port 9 (see <a href="#">Table 84: “10/100 Ports Control Registers,” on page 182</a> )
92h	8	Port 10 (see <a href="#">Table 84: “10/100 Ports Control Registers,” on page 182</a> )
93h	8	Port 11 (see <a href="#">Table 84: “10/100 Ports Control Registers,” on page 182</a> )
94h	8	Port 12 (see <a href="#">Table 84: “10/100 Ports Control Registers,” on page 182</a> )
95h	8	Port 13 (see <a href="#">Table 84: “10/100 Ports Control Registers,” on page 182</a> )
96h	8	Port 14 (see <a href="#">Table 84: “10/100 Ports Control Registers,” on page 182</a> )
97h	8	Port 15 (see <a href="#">Table 84: “10/100 Ports Control Registers,” on page 182</a> )
98h	8	Port 16 (see <a href="#">Table 84: “10/100 Ports Control Registers,” on page 182</a> )
99h	8	Port 17 (see <a href="#">Table 84: “10/100 Ports Control Registers,” on page 182</a> )
9Ah	8	Port 18 (see <a href="#">Table 84: “10/100 Ports Control Registers,” on page 182</a> )
9Bh	8	Port 19 (see <a href="#">Table 84: “10/100 Ports Control Registers,” on page 182</a> )
9Ch	8	Port 20 (see <a href="#">Table 84: “10/100 Ports Control Registers,” on page 182</a> )
9Dh	8	Port 21 (see <a href="#">Table 84: “10/100 Ports Control Registers,” on page 182</a> )
9Eh	8	Port 22 (see <a href="#">Table 84: “10/100 Ports Control Registers,” on page 182</a> )
9Fh	8	Port 23 (see <a href="#">Table 84: “10/100 Ports Control Registers,” on page 182</a> )

**Table 84: 10/100 Ports Control Registers**

<b>Bit</b>	<b>Name</b>	<b>R/W</b>	<b>Description</b>	<b>Default</b>
7:5	STP_STATE[2:0]	R/W	Spanning Tree Protocol State. CPU writes the current computed states of its Spanning Tree Algorithm for this port. <ul style="list-style-type: none"> <li>• 000 = No Spanning Tree (unmanaged mode).</li> <li>• 001 = Disabled State (Default for Managed mode).</li> <li>• 010 = Blocking State.</li> <li>• 011 = Listening State.</li> <li>• 100 = Learning State.</li> <li>• 101 = Forwarding State.</li> <li>• 110–111 = Reserved.</li> </ul> <b>Note:</b> Ignored when SW_FWDG_MODE = Unmanaged.	Controlled by HW_FWDG_EN Strap Option
4:2	RSVD	RO	Reserved Write default. Ignore on read	0
1	TX_DISABLE	R/W	Disables the transmit function of the port at the MAC 0 level. <ul style="list-style-type: none"> <li>• 1 = disable</li> <li>• 0 = enable</li> </ul>	
0	RX_DISABLE	R/W	Disables the receive function of the port at the MAC 0 level. <ul style="list-style-type: none"> <li>• 1 = disable</li> <li>• 0 = enable</li> </ul>	

## IMP Port Control Register (Page 01h/Addr A0h)

Table 85: IMP Port Control Register (Page 01h: Address A0h)

Bit	Name	R/W	Description	Default
7:5	STP_STATE[2:0]	R/W	<p>Spanning Tree Protocol State. CPU writes the current computed states of its Spanning Tree Algorithm for this port.</p> <ul style="list-style-type: none"> <li>• 000 = No Spanning Tree (unmanaged mode).</li> <li>• 001 = Disabled State.</li> <li>• 010 = Blocking State.</li> <li>• 011 = Listening State.</li> <li>• 100 = Learning State.</li> <li>• 101 = Forwarding State.</li> <li>• 110–111 = Reserved.</li> </ul> <p><b>Note:</b> Ignored when SW_FWDG_MODE = Unmanaged.</p>	Controlled by HW_FWDG_EN Strap Option
4	RX_UCST_EN	R/W	<p>Receive Unicast Enable.</p> <p>Enables the receipt of unicast frames on the IMP, when the IMP is configured as the Frame Management Port, and the frame was flooded due to no matching address table entry.</p> <p>When cleared, unicast frames that meet the Mirror Ingress/Egress Rules are still forwarded to the Frame Management Port.</p> <p><b>Note:</b> Ignored if the IMP is not selected as the Frame Management Port.</p>	0
3	RX_MCST_EN	R/W	<p>Receive Multicast Enable.</p> <p>Enables the receipt of multicast frames on the IMP, when the IMP is configured as the Frame Management Port, and the frame was flooded due to no matching address table entry.</p> <p>When cleared, multicast frames that meet the Mirror Ingress/Egress Rules are still forwarded to the Frame Management Port.</p> <p><b>Note:</b> Ignored if the IMP is not selected as the Frame Management Port.</p>	0
2	RX_BCST_EN	R/W	<p>Receive Broadcast Enable.</p> <p>Enables the receipt of broadcast frames on the IMP, when the IMP is configured as the Frame Management Port.</p> <p>When cleared, multicast frames that meet the Mirror Ingress/Egress Rules are still forwarded to the Frame Management Port.</p> <p><b>Note:</b> Ignored if the IMP is not selected as the Frame Management Port.</p>	0

**Table 85: IMP Port Control Register (Page 01h: Address A0h) (Cont.)**

Bit	Name	R/W	Description	Default
1	TX_DISABLE	R/W	Disables the transmit function of the port at the MAC 0 level. <ul style="list-style-type: none"> <li>• 1 = disable</li> <li>• 0 = enable</li> </ul>	
0	RX_DISABLE	R/W	Disables the receive function of the port at the MAC 0 level. <ul style="list-style-type: none"> <li>• 1 = disable</li> <li>• 0 = enable</li> </ul>	

## GigaPorts G0-G1 Control Registers (Page 01h/Addr A1h–A2h)

**Table 86: GigaPorts G0-G1 Control Registers (Page 01h/Addr A1h–A2h)**

Address	Bits	Register Name
A1h	8	GE port 0 (see <a href="#">Table 87: “GigaPorts Control Registers,” on page 184</a> )
A2h	8	GE port 1 (see <a href="#">Table 87: “GigaPorts Control Registers,” on page 184</a> )

**Table 87: GigaPorts Control Registers**

Bit	Name	R/W	Description	Default
7:5	STP_STATE[2:0]	R/W	Spanning Tree Protocol State. CPU writes the current computed states of its Spanning Tree Algorithm for this port. <ul style="list-style-type: none"> <li>• 000 = No Spanning Tree (unmanaged mode).</li> <li>• 001 = Disabled State.</li> <li>• 010 = Blocking State.</li> <li>• 011 = Listening State.</li> <li>• 100 = Learning State.</li> <li>• 101 = Forwarding State.</li> <li>• 110–111 = Reserved.</li> </ul> <b>Note:</b> Ignored when SW_FWDG_MODE = Unmanaged.	Controlled by HW_FWDG_EN Strap Option
4:2	RSVD	RO	Reserved Write default. Ignore on read	0
1	TX_DISABLE	R/W	Disables the transmit function of the port at the MAC level.	0
0	RX_DISABLE	R/W	Disables the receive function of the port at the MAC level.	0



## Status Control Register (Page 01h/Addr B0h)

*Table 88: Status Control Register (Page 01h: Address B0h)*

<i>Bit</i>	<i>Name</i>	<i>R/W</i>	<i>Description</i>	<i>Default</i>
7:1	RSVD	RO	Reserved Write default. Ignore on read	0
0	EN_IMP_RX_PAUSE_NOTAG	R/W	<ul style="list-style-type: none"> <li>1 = CPU to IMP port, standard PAUSE frame 1 without BRCM tag.</li> <li>0 = CPU to IMP port, requires BRCM tag for PAUSE frame</li> </ul>	

Broadcom Confidential

## Page 02h: Status Registers

**Table 89: Status Registers (Page 02h)**

<b>Address</b>	<b>Bits</b>	<b>Register Name</b>
00h–07h	64	“BIST Status 0 Register (Page 02h/Addr 00h–07h)” on page 187
08h–0Fh	64	“BIST Status 1 Register (Page 02h/Addr 08h–0Fh)” on page 188
10h–13h	64	“Link Status Summary Register (Page 02h/Addr 10h–17h)” on page 189
18h–1Fh	64	“Link Status Change Register (Page 02h/Addr 18h–1Fh)” on page 190
20h–27h	64	“Port Speed Summary Register (Page 02h/Addr 20h–27h)” on page 191
28h–2Fh	64	“Duplex Status Summary Register (Page 02h/Addr 28h–2Fh)” on page 192
30h–37h	64	“Pause Status Summary Register (Page 02h/Addr 30h–37h)” on page 193
38h–4Fh	Reserved	
60h–EFh	Reserved	
F0h–F7h	–	SPI Data I/O[0:7]
F8h–FDh	Reserved	
FEh	–	SPI Status
FFh	8	Page Register

## BIST Status 0 Register (Page 02h/Addr 00h–07h)

Table 90: BIST Status 0 Register (Page 02h/Addr 00h–07h)

Bit	Name	R/W	Description	Default
63	MAC2VLAN_MBIST_ERR	RO	MAC-based Vlan Table Memory BIST Error	0
62	PROTOCOL2VLAN_MBIST_ERR	RO	Protocol-based Vlan Table Memory BIST Error	0
61	FLOW2VLAN_MBIST_ERR	RO	Flow-based Vlan Table Memory BIST Error	0
60	IPMC_MBIST_ERR	RO	IP Multicast Table Memory BIST Error.	0
59	MSPT_MBIST_ERR	RO	Multiple Spanning Tree Table Memory BIST Error.	0
58	CFP_TCAM_LOGIC_ERR	RO	CFP TCAM Logic Error.	0
57	CFP_CNT_MBIST_ERR	RO	CFP Counter Memory BIST Error.	0
56	CFP_ACT_MBIST_ERR	RO	CFP Action Memory BIST Error.	0
55	CFP_RM_MBIST_ERR	RO	CFP Rate Meter Memory BIST Error.	0
54:39	CFP_TCAM_MBIST_ERR[15:0]	RO	CFP TCAM BIST Error.	0
38:30	MIB_MBIST_ERR[8:0]	RO	MIB Memory BIST Error. <ul style="list-style-type: none"> <li>• Bit 38: Reserved</li> <li>• Bit 37: Reserved</li> <li>• Bit 36: GigaPort 1</li> <li>• Bit 35: GigaPort 0</li> <li>• Bit 34: IMP</li> <li>• Bit 33: Reserved</li> <li>• Bit 32: 10/100 Ports 23-16</li> <li>• Bit 31: 10/100 Ports 15-8</li> <li>• Bit 30: 10/100 Ports 7-0</li> </ul>	0
29	GTXQ_MBIST_ERR	RO	Global TXQ BIST Error.	0
28:0	TXQ_MBIST_ERR[28:0]	RO	Per-port TXQ BIST Error. <ul style="list-style-type: none"> <li>• Bits 28-27: Reserved</li> <li>• Bits 26-25: GigaPorts 1-0</li> <li>• Bit 24: IMP</li> <li>• Bits 23-0: 10/100 ports [port 23-port 0]</li> </ul>	0

## BIST Status 1 Register (Page 02h/Addr 08h–0Fh)

Table 91: BIST Status 1 Register (Page 02h/Addr 08h–0Fh)

Bit	Name	R/W	Description	Default
63:11	RSVD	RO	Reserved.	0
10	FT_MCOL_DEFECT	RO	Frame Buffer Memory Defect ( $\geq 1$ error).	0
9	AT_MCOL_DEFECT	RO	Address Table Defect ( $\geq 1$ error).	0
8	VT_MCOL_DEFECT	RO	VLAN Table defect ( $\geq 1$ error).	0
7	FM_MCOL_DEFECT	RO	Frame Buffer Memory Failed ( $\geq 2$ errors).	0
6	AT_MCOL_DEFECT	RO	Address Table Failed ( $\geq 2$ errors).	0
5	VT_MCOL_DEFECT	RO	VLAN Table Failed ( $\geq 2$ errors).	0
4	FM_ECC_MBIST_ERR	RO	Frame Buffer ECC Memory BIST Error.	0
3	BFC_MBIST_ERR	RO	Buffer Control Memory BIST Error.	0
2	IRC_MBIST_ERR	RO	Ingress Rate Control Configuration Table BIST Error.	0
1	ERC_MBIST_ERR	RO	Egress Rate Control Configuration Table BIST Error.	0
0	VLAN2VLAN_MBIST_ERR	RO	VLAN Translation Table Memory Error.	0

## Link Status Summary Register (Page 02h/Addr 10h–17h)

*Table 92: Link Status Summary Register (Page 02h: Address 10h–17h)*

<b>Bit</b>	<b>Name</b>	<b>R/W</b>	<b>Description</b>	<b>Default</b>
63:51	RSVD	RO	Reserved Write default. Ignore on read	0
50:24	LINK_STATUS[50:24]	RO	<p>Link Status. A 27-bit field indicating the Link Status for each 10/100Base-T port, the MII port and the 2-Gbit ports.</p> <ul style="list-style-type: none"> <li>• Bit 50 = GigaPort G1</li> <li>• Bit 49 = GigaPort G0</li> <li>• Bit 48 = IMP/MII</li> <li>• Bits 47:24 = 10/100 ports [port 23–port 0] <ul style="list-style-type: none"> <li>– 0 = Link Fail.</li> <li>– 1 = Link Pass.</li> </ul> </li> </ul> <p><b>Note:</b> Link status for the IMP/MII port can only be reported for an external transceiver by:  - Using the MII_LINK# pin to pass the transceiver's state to the BCM53242M:  - Using the CPU to read the link status via the MDC/MDIO interface and write this back to the <a href="#">"Page 01h: Control 1 Registers" on page 174.</a></p>	0
23:0	RSVD	–	Reserved	0

## Link Status Change Register (Page 02h/Addr 18h–1Fh)

*Table 93: Link Status Change Register (Page 02h: Address 18h–1Fh)*

<b>Bit</b>	<b>Name</b>	<b>R/W</b>	<b>Description</b>	<b>Default</b>
63:51	RSVD	RO	Reserved Write default. Ignore on read	0
50:24	LINK_STATUS_CHANGE[50:24]	RC	<p>Link Status Change.</p> <p>A 27-bit field indicating that the Link Status for each individual 10/100Base-T port, MII, or 2 gigabit ports had changed since the last read operation.</p> <ul style="list-style-type: none"> <li>• Bit 50 = GigaPort G1</li> <li>• Bit 49 = GigaPort G0</li> <li>• Bit 48 = IMP/MII</li> <li>• Bits 47:24 = 10/100 ports [port 23–port 0]</li> </ul> <p>Upon change of link status, a bit remains set until cleared by a read operation.</p> <ul style="list-style-type: none"> <li>• 0 = Link Status Constant.</li> <li>• 1 = Link Status Change.</li> </ul> <p>Link status change for the IMP/MII port can only be reported for an external transceiver by using the:</p> <ul style="list-style-type: none"> <li>• MII_LINK# pin to pass the transceiver's state to the BCM53242M.</li> <li>• CPU to read the link status via the MDC/MDIO interface and write this back to the <a href="#">"Page 01h: Control 1 Registers"</a> on page 174.</li> </ul>	0
23:0	RSVD	–	Reserved	0

## Port Speed Summary Register (Page 02h/Addr 20h–27h)

*Table 94: Port Speed Summary Register (Page 02h: Address 20h–27h)*

<b>Bit</b>	<b>Name</b>	<b>R/W</b>	<b>Description</b>	<b>Default</b>
63:54	RSVD	RO	Reserved Write default. Ignore on read	0
53:24	PORT_SPEED[53:24]	RO	<p>Port Speed.</p> <p>Bits [53:48] field indicating the operating speed for each GigaPort and IMP/MII port.</p> <ul style="list-style-type: none"> <li>• Bits [53:52] for GigaPort G1.</li> <li>• Bits [51:50] for GigaPort G0.</li> <li>• Bits [49:48] for IMP/MII port. <ul style="list-style-type: none"> <li>– 00 = 10 Mbps</li> <li>– 01 = 100 Mbps</li> <li>– 10 = 1000 Mbps</li> </ul> </li> </ul> <p>Bits[47:24] field indicating the operating speed for each 10/100Base-T port</p> <ul style="list-style-type: none"> <li>• Bits 47:24 = 10/100 ports [port 23–port 0] respectively. <ul style="list-style-type: none"> <li>– 0 = 10 Mbps</li> <li>– 1 = 100 Mbps</li> </ul> </li> </ul> <p><b>Note:</b> Port speed for the IMP/MII port can only be reported for an external transceiver by using the:</p> <ul style="list-style-type: none"> <li>– MII_SPD# strap to pass the transceiver's default state to the BCM53242M.</li> <li>– CPU to read the port speed via the MCD/MDIO interface and write this back to the <a href="#">"Page 01h: Control 1 Registers"</a> on <a href="#">page 174</a>.</li> </ul>	0
23:0	RSVD	–	Reserved	0

## Duplex Status Summary Register (Page 02h/Addr 28h–2Fh)

*Table 95: Duplex Status Summary Register (Page 02h: Address 28h–2Fh)*

<b>Bit</b>	<b>Name</b>	<b>R/W</b>	<b>Description</b>	<b>Default</b>
63:51	RSVD	RO	Reserved Write default. Ignore on read	0
50:24	DUPLEX_STATE[50:24]	RC	<p>Duplex State.</p> <p>A 27-bit field indicating that the Duplex State for each individual 10/100Base-T port, IMP/MII, or 2-Gbit ports.</p> <ul style="list-style-type: none"> <li>• Bit 50 = GigaPort G1</li> <li>• Bit 49 = GigaPort G0</li> <li>• Bit 48 = IMP/MII</li> <li>• Bits 47:24 = 10/100 ports [port 23–port 0] <ul style="list-style-type: none"> <li>– 0 = Half-duplex.</li> <li>– 1 = Full-duplex.</li> </ul> </li> </ul> <p><b>Note:</b> The duplex state for the IMP/MII port can only be reported for an external transceiver by:</p> <ul style="list-style-type: none"> <li>- Using the MII_DUPLX# strap option to pass the transceiver's default state to the BCM53242M.</li> <li>- Using the CPU to read the half/full-duplex state via the MDC/MDIO interface and write this back to the <a href="#">“Page 01h: Control 1 Registers”</a> on page 174.</li> </ul>	0
23:0	RSVD	–	Reserved	0



## Pause Status Summary Register (Page 02h/Addr 30h–37h)

**Table 96: Pause Status Summary Register (Page 02h: Address 30h–37h)**

Bit	Name	R/W	Description	Default
63:54	RSVD	RO	Reserved Write default. Ignore on read	0
53:52	PAUSE_STATE_G1[1:0]	RO	Pause state for GigaPort G1. <ul style="list-style-type: none"> <li>• Bit 1 = for TX.</li> <li>• Bit 0 = for RX.</li> </ul>	0
51:50	PAUSE_STATE_G0[1:0]	RO	Pause state for GigaPort G0. <ul style="list-style-type: none"> <li>• Bit 1 = for TX.</li> <li>• Bit 0 = for RX.</li> </ul>	0
49:48	PAUSE_STATE_IMP	RO	Pause state for IMP port <ul style="list-style-type: none"> <li>• Bit 1 = for TX.</li> <li>• Bit 0 = for RX.</li> </ul> <p><b>Note:</b> The pause state for the IMP port can only be reported for an external transceiver by using the CPU to read the negotiated pause state via the MCD/MDIO interface and write this back to the Port Status Override register (page 0h, Address B9h).</p>	0
47:24	PAUSE_STATE[23:0]	RC	Pause state. A 24-bit field indicating the PAUSE state for each 10/100Base-T port. <ul style="list-style-type: none"> <li>• Bits [47:24] = 10/100 ports [port 23–port 0] respectively.</li> <li>• 0 = No pause.</li> <li>• 1 = Pause.</li> </ul>	0
23:0	RSVD	–	Reserved	0

## Page 03h: Management Mode Registers

**Table 97: Management Mode Registers (Page 03h)**

Address	bits	Register Name
00h	8	<a href="#">“Global Management Configuration Register (Page 03h/Addr 00h)” on page 195</a>
01h	8	<a href="#">“Table Memory Reset Control Register (Page 03h/Addr 01h)” on page 195</a>
02h	8	<a href="#">“Management Port ID Register (Page 03h/Addr 02h)” on page 196</a>
03h	Reserved	
04h–07h	32	<a href="#">“Reset Table Memory Register (Page 03h: Address 03h)” on page 197</a>
08h–0Fh	64	<a href="#">“RMON MIB Steering Register (Page 03h/Addr 08h–0Fh)” on page 198</a>
10h–17h	64	<a href="#">“Mirror Capture Control Register (Page 03h/Addr 10h–17h)” on page 199</a>

**Table 97: Management Mode Registers (Page 03h)**

<b>Address</b>	<b>bits</b>	<b>Register Name</b>
18h–1Fh	64	“Ingress Mirror Control Register (Page 03h/Addr 18h–1Fh)” on page 200
20h–21h	16	“Ingress Mirror Divider Register (Page 03h/Addr 20h–21h)” on page 200
22h–27h	48	“Ingress Mirror MAC Address Register (Page 03h/Addr 22h–27h)” on page 201
28h–2Fh	64	“Egress Mirror Control Register (Page 03h/Addr 28h–2Fh)” on page 202
30h–31h	16	“Egress Mirror Divider Register (Page 03h/Addr 30h–31h)” on page 203
32h–37h	48	“Egress Mirror MAC Address Register (Page 03h/Addr 32h–37h)” on page 203
38h–3Fh	Reserved	
40h	8	“Special Management Control Register (Page 03h/Addr 40h)” on page 204
41h–4Fh	Reserved	
50h	8	“MIB Snapshot Control Register (Page 03h/Addr 50h)” on page 205
51h–5Fh	Reserved	
60h–67h	64	“Ingress RMON Register (Page 03h/Addr 60h–67h)” on page 206
68h–69h	16	“Egress RMON Register (Page 03h/Addr 68h–69h)” on page 207
6Ah–7Bh	Reserved	
7Ch	8	“Chip Reset Control Register (Page 03h/Addr 7Ch)” on page 207
7Dh–87h	Reserved	
88h	–	Reserved
89h–8Fh	Reserved	
–	–	Reserved
93h–EFh	Reserved	
F0h–F7h	–	SPI Data I/O[0:7]
F8h–FDh	Reserved	
FEh	–	SPI Status
FFh	8	Page Register

## Global Management Configuration Register (Page 03h/Addr 00h)

**Table 98: Global Management Configuration Register (Page 03h: Address 00h)**

Bit	Name	R/W	Description	Default
7:6	FRM_MNGT_PORT	R/W	Frame Management Port. Defines the physical port used to forward management frames directed to the switch. <ul style="list-style-type: none"> <li>00 = No Management Port</li> <li>01 = Reserved</li> <li>10 = IMP (In-band Management Port)</li> <li>11 = Reserved</li> </ul> These bits are ignored when SW_FWD_MODE = 0 (unmanaged) in the Switch Mode register Page 00h, Address 00h.	00
5	RSVD	RO	Reserved Write default. Ignore on read	0
4:3	IGMP_MLD_CHK	R/W	<ul style="list-style-type: none"> <li>11 = IGMP/MLD snooping is enabled. IGMP/MLD packet is forwarded according to its original port forwarding map from DA/VID look-up in addition to IMP port.</li> <li>01 = IGMP/MLD snooping is enabled. IGMP/MLD packet is forwarded to IMP port only.</li> <li>00 = IGMP/MLD snooping is disabled.</li> </ul>	0
2	RSVD	RO	Reserved Write default. Ignore on read	0
1	RX_BPDU_EN	R/W	Receive BPDU Enable. Enables all ports to receive BPDUs and forward to the defined Physical Management Port. Management CPU must set this bit to globally allow BPDUs to be received.	0
0	RSVD	–	Reserved	0

## Table Memory Reset Control Register (Page 03h/Addr 01h)

**Table 99: Table Memory Reset Control Register (Page 03h/Addr 01h)**

Bit	Name	R/W	Description	Default
7:5	RSVD	R/W	Reserved	00
4	RST_MSPT	SC	Reset Multiple Spanning Tree Table Setting bit = 1 sets the table content to zero, and the bit resets to 0 when the operation is done.	0
3	RST_IPMC	SC	Reset L2 Multicast Table Setting bit = 1 sets the table content to zero, and the bit resets to 0 when the operation is done.	0

**Table 99: Table Memory Reset Control Register (Page 03h/Addr 01h)**

<b>Bit</b>	<b>Name</b>	<b>R/W</b>	<b>Description</b>	<b>Default</b>
2	RST_VT	SC	Reset VLAN Table Setting bit = 1 sets the table content to zero, and the bit resets to 0 when the operation is done.	0
1	RST_ARL	SC	Reset ARL Table Setting bit = 1 sets the table content to zero, and the bit resets to 0 when the operation is done.	0
0	RST_MIB_CNTR	SC	Reset MIB counters Setting bit = 1 sets the table content to zero, and the bit resets to 0 when the operation is done.	0

## Management Port ID Register (Page 03h/Addr 02h)

**Table 100: Management Port ID Register (Page 03h: Address 02h)**

<b>Bit</b>	<b>Name</b>	<b>R/W</b>	<b>Description</b>	<b>Default</b>
7:6	RSVD	RO	Reserved Write default. Ignore on read	0
5:0	PORT ID	R/W	Port ID where Management Port is located. This must be programmed consistent with the Frame Management Port in the Global Management Configuration register. <b>Note:</b> Only IMP port (Port 48 [30h]) is legal value (i.e., not to be set to any other value).	0x30

## Reset Table Memory Register (Page 03h: Address 03h)

**Table 101: Reset Table Memory Register (Page 03h: Address 03h)**

Bit	Name	R/W	Description	Default
7:6	RSVD	–	Reserved	0
5:0	RST_TBL_MEM	SC	<p>When the corresponding bit is set, the table memory is reset.</p> <ul style="list-style-type: none"> <li>• Bit 5: Resets the port-based egress rate control configuration memory</li> <li>• Bit 4: Resets the port-based ingress rate control configuration memory</li> <li>• Bit 3: Resets the Flow-based VLAN table</li> <li>• Bit 2: Resets the Protocol-based VLAN table</li> <li>• Bit 1: Resets the MAC-based VLAN table</li> <li>• Bit 0: Resets the VLAN-based VLAN table</li> </ul>	0

## Aging Time Control Register (Page 03h/Addr 04h–07h)

**Table 102: Aging Time Control Register (Page 03h: Address 04h–07h)**

Bit	Name	R/W	Description	Default
31:20	RSVD	RO	Reserved Write default. Ignore on read	0
19:0	AGE_TIME	R/W	<p>Specifies the aging time in seconds for dynamically learned address. Maximum age time is 1,048,575s.</p> <p><b>Note:</b> While 802.1D specifies a range of values of 10–1,000,000s, this register does not enforce this range. Setting the AGE_TIME to 0 disables the aging process.</p>	0x12C

## RMON MIB Steering Register (Page 03h/Addr 08h–0Fh)

*Table 103: RMON MIB Steering Register (Page 03h: Address 08h–0Fh)*

<b>Bit</b>	<b>Name</b>	<b>R/W</b>	<b>Description</b>	<b>Default</b>
63:51	RSVD	RO	Reserved Write default. Ignore on read	–
50:24	OR_RMON_RCV[52:24]	R/W	Override RMON Receive. Forces the RMON packet size “bucket” counters from the normal default of snooping on the receive side of the MAC, to the transmit side. This allows the RMON bucket counters to snoop either transmit or receive, allowing full-duplex MAC support. <ul style="list-style-type: none"> <li>• Bit 50 = GigaPort G1</li> <li>• Bit 49 = GigaPort G0</li> <li>• Bit 48 = IMP</li> <li>• Bits 47:24 = 10/100 ports [port 23–port 0]</li> </ul>	0
23:0	RSVD	–	Reserved	0

## Mirror Capture Control Register (Page 03h/Addr 10h–17h)

*Table 104: Mirror Capture Control Register (Page 03h: Address 10h–17h)*

<b>Bit</b>	<b>Name</b>	<b>R/W</b>	<b>Description</b>	<b>Default</b>
63	MIRROR_ENABLE	R/W	Global enable/disable for all mirroring on this chip. When reset, mirroring is disabled. When set, mirroring is enabled according to ingress and egress control rules, to the port designated as MIRROR_CAPTURE_PORT.	0
62	RSVD	–	Reserved	1
61:51	RSVD	RO	Reserved Write default. Ignore on read	0
50:24	MIRROR_CAPTURE_PORT	R/W	Mirror Capture Port. Bit mask which identifies the single unique port which is designated as the port to which all ingress and/or egress traffic is mirrored on this chip/system. <ul style="list-style-type: none"> <li>• Bit 50 = GigaPort G1</li> <li>• Bit 49 = GigaPort G0</li> <li>• Bit 48 = IMP</li> <li>• Bits 47:24 = 10/100 ports [port 23–port 0]</li> </ul>	0
23:0	RSVD	–	Reserved	0

## Ingress Mirror Control Register (Page 03h/Addr 18h–1Fh)

**Table 105: Ingress Mirror Control Register (Page 03h: Address 18h–1Fh)**

Bit	Name	R/W	Description	Default
63:62	IN_MIRROR_FILTER	R/W	Ingress Mirror Filter. Defines conditions under which frames received on a port that has been selected in the IN_MIRROR_MASK[52:24], is compared to in order to determine if they should be forwarded to the MIRROR_CAPTURE_PORT. <ul style="list-style-type: none"> <li>• 00 = Mirror all ingress frames</li> <li>• 01 = Mirror all received frames with DA = IN_MIRROR_MAC</li> <li>• 10 = Mirror all received frames with SA = IN_MIRROR_MAC</li> <li>• 11 = Reserved.</li> </ul>	0
61	IN_DIV_EN	R/W	Ingress Divider Enable. Mirror every n <sup>th</sup> received frame (n=IN_MIRROR_DIV, defined in Register Page 03h, Address 20h) that has passed through the IN_MIRROR_FILTER.	0
60:51	RSVD	RO	Reserved Write default. Ignore on read	0
50:24	IN_MIRROR_MASK[50:24]	R/W	Ingress Mirror Port Mask. A 27-bit mask which selectively allows any port with its corresponding bit set, to be mirrored to the port identified by the MIRROR_CAPTURE_PORT value. <b>Note:</b> While multiple bits in a device may be set, severe congestion and/or frame loss may occur if excessive bandwidth from the mirrored port(s) is directed to the MIRROR_CAPTURE_PORT. <ul style="list-style-type: none"> <li>• Bit 50 = GigaPort G1</li> <li>• Bit 49 = GigaPort G0</li> <li>• Bit 48 = IMP</li> <li>• Bits 47:24 = 10/100 ports [port 23–port 0]</li> </ul>	0
23:0	RSVD	–	Reserved	0

## Ingress Mirror Divider Register (Page 03h/Addr 20h–21h)

**Table 106: Ingress Mirror Divider Register (Page 03h: Address 20h–21h)**

Bit	Name	R/W	Description	Default
15:10	RSVD	RO	Reserved Write default. Ignore on read	0



**Table 106: Ingress Mirror Divider Register (Page 03h: Address 20h–21h)**

<b>Bit</b>	<b>Name</b>	<b>R/W</b>	<b>Description</b>	<b>Default</b>
9:0	IN_MIRROR_DIV	R/W	<p>Ingress Mirror Divider.</p> <p>Receive frames that have passed the IN_MIRROR_FILTER rule can further reduce the overall number of frames forwarded to the MIRROR_CAPTURE_PORT to avoid the congestion. When the IN_DIV_EN bit in the Ingress Mirror Control register is set, only one in n frames is mirrored.</p> <p><b>Note:</b> Where n = IN_MIRROR_DIV and n must not be set to 0.</p>	0

## Ingress Mirror MAC Address Register (Page 03h/Addr 22h–27h)

**Table 107: Ingress Mirror MAC Address Register (Page 03h: Address 22h–27h)**

<b>Bit</b>	<b>Name</b>	<b>R/W</b>	<b>Description</b>	<b>Default</b>
47:0	IN_MIRROR_MAC	R/W	<p>Ingress Mirror MAC Address.</p> <p>MAC address that is compared against ingress frames in accordance with the IN_MIRROR_FILTER rules in Register Page 03h, Address 18h.</p>	0

## Egress Mirror Control Register (Page 03h/Addr 28h–2Fh)

**Table 108: Egress Mirror Control Register (Page 03h: Address 28h–2Fh)**

Bit	Name	R/W	Description	Default
63:62	OUT_MIRROR_FILTER	R/W	Egress Mirror Filter. Defines the type of Egress frames to be mirrored. <ul style="list-style-type: none"> <li>• 00: Mirror all egress frames</li> <li>• 01: Mirror all transmitted frames with DA = OUT_MIRROR_MAC</li> <li>• 10: Mirror all transmitted frames with SA = OUT_MIRROR_MAC</li> <li>• 11: Reserved.</li> </ul>	0
61	OUT_DIV_EN	R/W	Egress Divider Enable. Mirror every nth transmitted frame (n=OUT_MIRROR_DIV) that has passed through the OUT_MIRROR_FILTER.	0
60:51	RSVD	RO	Reserved Write default. Ignore on read	0
50:24	OUT_MIRROR_MASK[50:24]	R/W	Egress Mirror Port Mask is to select the port(s) Egress traffic be forwarded to the MIRROR_CAPTURE_PORT. A 27-bit mask which selectively allows any port with its corresponding bit set, to be mirrored to the port identified by the MIRROR_CAPTURE_PORT value. <b>Note:</b> While multiple bits in a device may be set, severe congestion and/or frame loss may occur if excessive bandwidth from the mirrored port(s) is directed to the MIRROR_CAPTURE_PORT. <ul style="list-style-type: none"> <li>• Bit 50 = GigaPort G1</li> <li>• Bit 49 = GigaPort G0</li> <li>• Bit 48 = IMP</li> <li>• Bits 47:24 = 10/100 ports [port 23–port 0]</li> </ul>	0
23:0	RSVD	–	Reserved	–

## Egress Mirror Divider Register (Page 03h/Addr 30h–31h)

*Table 109: Egress Mirror Divider Register (Page 03h: Address 30h–31h)*

<i>Bit</i>	<i>Name</i>	<i>R/W</i>	<i>Description</i>	<i>Default</i>
15:10	RSVD	RO	Reserved Write default. Ignore on read	0
9:0	OUT_MIRROR_DIV	R/W	Egress Mirror Divider. Transmit frames that have passed the OUT_MIRROR_FILTER rule can further reduced the overall number of frames forwarded to the MIRROR_CAPTURE_PORT to avoid the congestion. When the OUT_DIV_EN bit in the Egress Mirror Control register is set, only one in n frames is mirrored. <b>Note:</b> Where n = OUT_MIRROR_DIV and n must not be set to 0.	0

## Egress Mirror MAC Address Register (Page 03h/Addr 32h–37h)

*Table 110: Egress Mirror MAC Address Register (Page 03h: Address 32h–37h)*

<i>Bit</i>	<i>Name</i>	<i>R/W</i>	<i>Description</i>	<i>Default</i>
47:0	OUT_MIRROR_MAC	R/W	Egress Mirror MAC Address. MAC address that is compared against egress frames in accordance with the OUT_MIRROR_FILTER rules.	0

## Special Management Control Register (Page 03h/Addr 40h)

**Table 111: Special Management Control Register (Page 03h: Address 40h)**

Bit	Name	R/W	Description	Default
7:6	RSVD	–	Reserved	10
5	EN_ARP_CONTROL	R/W	ARP Frame Control. <ul style="list-style-type: none"> <li>0 = ARP frames are flooded in the defined VLAN domain, but are not forwarded to IMP if the IMP does not belong to the same VLAN.</li> <li>1 = ARP frames are flooded in the defined VLAN domain and also copied to the IMP even if the IMP is not part of the same VLAN group.</li> </ul>	0
4	BYPASS_SPT_CHK	R/W	When this bit is set, incoming packet with DA= 01-80-c2-00-00-00 ~ 01-80-c2-00-00-10 bypasses spanning tree state checking.	0
3	En_ALL_Zero_DA_Drop	R/W	Drop All 0 MAC DA Frame Control. When set, any frame with MAC DA = 00:00:00:00:00:00 is dropped otherwise it is forwarded as is.	0
2	RSVD	R/W	Write as default. Ignore on read.	0
1	PASS_ARP_DHCP	R/W	Enable to Pass ARP and DHCP frames. When management mode is enabled, and if bit 2, RX_BCST_EN (Page 01h/Addr A0h) is disabled, set this bit to 1 to allow the receiving of ARP and DHCP packets.	0
0	PASS_BPDU/Rsvd-MCAST	R/W	Enable to Pass BPDU and Reserved Multicast Frames. Setting this bit allows any port in spanning tree Disable state to forward BPDU and reserved multicast frames within range 01:80:C2:00:00:02 through 01:80:C2:00:00:0F to the IMP port.	0

## MIB Snapshot Control Register (Page 03h/Addr 50h)

**Table 112: MIB Snapshot Control Register (Page 03h: Address 50h)**

Bit	Name	R/W	Description	Default
7	SNAPSHOT_START/DONE	R/W (SC)	Snapshot Start/Done Command. When enabled, this bit is self clear to indicate that the process is completed and the snapshot is ready at <a href="#">Table : "Page 85h: Snapshot Port MIB Registers,"</a> on page 338. <ul style="list-style-type: none"> <li>1 = Initiate MIB Snapshot function.</li> <li>0 = Snapshot function completed.</li> </ul>	0
6	SNAPSHOT_MIRROR	RO	1 = enable read address to port MIB from MIB snapshot memory 0 = enable to read from port MIB memory	0
5:0	SNAPSHOT_PORT	RO	MIB Snapshot Port Number. These bits specify the port number to snapshot. <ul style="list-style-type: none"> <li>50 = GigaPort G1</li> <li>49 = GigaPort G0</li> <li>48 = IMP</li> <li>24~47 = 10/100 ports [port 0-port 23]</li> <li>0 ~ 23 = Reserved</li> </ul>	0

## Ingress RMON Register (Page 03h/Addr 60h–67h)

**Table 113: Ingress RMON Register (Page 03h: Address 60h–67h)**

Bit	Name	R/W	Description	Default
63:60	INGRESS_CFG	R/W	Ingress RMON Setting. An exponential value indicating the percentage of traffic that is forwarded to CPU due to Ingress Extended RMON. Percentage = $1/(2^{\text{INGRESS\_CFG}})$	Fh
59:58	INGRESS_PRI	R/W	Ingress RMON Priority Define which priority queue to use for Ingress Extended RMON. <ul style="list-style-type: none"> <li>• 11 = Queue 3</li> <li>• 10 = Queue 2</li> <li>• 01 = Queue 1</li> <li>• 00 = Queue 0</li> </ul>	0
57:51	RSVD	RO	Reserved Write default. Ignore on read	0
50:24	EN_INGRESS_PORTMAP	R/W	Ingress RMON Enabled Port Map. A 27-bit mask which selectively allows any port with its corresponding bit set, to enable Ingress Extended RMON. <b>Note:</b> Bit 48 is reserved and must be set to 0. <ul style="list-style-type: none"> <li>• Bit 50 = GigaPort G1</li> <li>• Bit 49 = GigaPort G0</li> <li>• Bit 48 = Reserved. Must be 0.</li> <li>• Bits 47:24 = 10/100 ports [port 23–port 0]</li> </ul>	0
23:0	RSVD	–	Reserved	0

## Egress RMON Register (Page 03h/Addr 68h–69h)

Table 114: Egress RMON Register (Page 03h: Address 68h–69h)

Bit	Name	R/W	Description	Default
15:12	EGRESS_CFG	R/W	Egress RMON Setting. An exponential value indicating the percentage of traffic that is forwarded to CPU due to Ingress Extended RMON. Percentage = $1/(2^{\text{EGRESS\_CFG}})$	Fh
11:10	EGRESS_PRI	R/W	Egress RMON Priority Define which priority queue to use for Egress Extended RMON. <ul style="list-style-type: none"> <li>11 = Queue 3</li> <li>10 = Queue 2</li> <li>01 = Queue 1</li> <li>00 = Queue 0</li> </ul>	0
9:7	RSVD	RO	Reserved Write default. Ignore on read	0
6	EN_EGRESS_RMON	R/W	Enable Egress RMON <ul style="list-style-type: none"> <li>1 = Enable</li> <li>0 = Disable</li> </ul>	0
5:0	EGRESS_RMON_PORT	R/W	Egress RMON Port. Define which port is Egress RMON Port. <ul style="list-style-type: none"> <li>50 = GigaPort G1</li> <li>49 = GigaPort G0</li> <li>48 = IMP</li> <li>24~47 = 10/100 ports [port 0-port 23]</li> <li>0 ~ 23 = Reserved</li> </ul>	0

## Chip Reset Control Register (Page 03h/Addr 7Ch)

Table 115: Chip Reset Control Register (Page 03h: Address 7Ch)

Bit	Name	R/W	Description	Default
7:1	RSVD	RO	Reserved Write default. Ignore on read	0
0	RST_CHIP	R/W (SC)	Reset Chip. <ul style="list-style-type: none"> <li>1 = Reset the entire chip.</li> <li>0 = Resume normal operation</li> </ul> <p><b>Note:</b> This bit is self clear</p>	0

## Page 04h: ARL Control Register

**Table 116: ARL Control Registers (Page 04h)**

Address	Bits	Register Name
00h	8	"Global ARL Configuration Register (Page 04h/Addr 00h)" on page 208
01h–03h	Reserved	
04h–09h	48	"BPDU Multicast Address Register (Page 04h/Addr 04h–09h)" on page 209
0Ah–0Fh	Reserved	
10h–15h	48	"Multiport Address 1 Register (Page 04h/Addr 10h–15h)" on page 209
16h–17h	Reserved	
18h–1Fh	64	"Multiport Vector 1 Register (Page 04h/Addr 18h–1Fh)" on page 210
20h–25h	48	"Multiport Address 2 Register (Page 04h/Addr 20h–25h)" on page 210
26h–27h	Reserved	
28h–2Fh	64	"Multiport Vector 2 Register (Page 04h/Addr 28h–2Fh)" on page 210
30h–EFh	Reserved	
F0h–F7h	–	SPI Data I/O[0:7]
F8h–FDh	Reserved	
FEh	–	SPI Status
FFh	8	Page Register

## Global ARL Configuration Register (Page 04h/Addr 00h)

**Table 117: Global ARL Configuration Register (Page 04h: Address 00h)**

Bit	Name	R/W	Description	Default
7:5	Reserved	RO	Reserved. Write default. Ignore on read.	0
4	MPORT_ADDR_EN	R/W	Multiport Address Enable. <ul style="list-style-type: none"> <li>When bit 4 is set to 1 by the host, a frame with matching DAs to the Multiport Address 1 and/or 2 registers is forwarded to the ports defined in their associated Multiport Vector 1 and/or 2 registers.</li> <li>When bit 4 is set to 0 (default): A frame with matching DAs to the Multiport Address 1 and/or 2 registers is forwarded to the IMP port. This allows for support of User defined BPDU packets.</li> </ul> <p><b>Note:</b> If only one multiport address is required, the host should write both Multiport Address/Vector entries to the same value.</p>	0



**Table 117: Global ARL Configuration Register (Page 04h: Address 00h)**

<b>Bit</b>	<b>Name</b>	<b>R/W</b>	<b>Description</b>	<b>Default</b>
3:0	RSVD	RO	Reserved. Write default. Ignore on read.	0

## BPDU Multicast Address Register (Page 04h/Addr 04h–09h)

**Table 118: BPDU Multicast Address Register (Page 04h: Address 04h–09h)**

<b>Bit</b>	<b>Name</b>	<b>R/W</b>	<b>Description</b>	<b>Default</b>
47:0	BPDU_MC_ADDR	R/W	BPDU Multicast Address 1. Defaults to the 802.1 defined reserved multicast address for the Bridge Group Address. Programming to an alternate value allows support of proprietary protocols in place of the normal Spanning Tree Protocol. Frames with a matching DA to this address are forwarded to the designated management port (IMP).	01-80-C2-00-00-00h

## Multiport Address 1 Register (Page 04h/Addr 10h–15h)

**Table 119: Multiport Address 1 Register (Page 04h: Address 10h–15h)**

<b>Bit</b>	<b>Name</b>	<b>R/W</b>	<b>Description</b>	<b>Default</b>
47:0	MPORT_ADDR_1	R/W	Multiport Address 1. Allows a frames with a matching DA to this address to be forwarded to any programmable group of ports on the chip, as defined in the bit map in the Multiport Vector 1 register. Must be enabled using the MPORT_ADDR_EN bit in the Global ARL Configuration register.	00-00-00-00-00-00h

## Multiport Vector 1 Register (Page 04h/Addr 18h–1Fh)

*Table 120: Multiport Vector 1 Register (Page 04h: Address 18h–1Fh)*

<b>Bit</b>	<b>Name</b>	<b>R/W</b>	<b>Description</b>	<b>Default</b>
63:51	Reserved	RO	Reserved Write default. Ignore on read.	0
50:24	MPORT_VCTR_1 [50:24]	R/W	Multiport Vector 1. A 27-bit mask corresponding to the physical ports on the chip. A frame with a DA matching the content of the Multiport Address 1 register is forwarded to each port with a bit set in the Multiport Vector 1 bit map. <ul style="list-style-type: none"> <li>• Bit 50 = GigaPort G1</li> <li>• Bit 49 = GigaPort G0</li> <li>• Bit 48 = IMP</li> <li>• Bits 47:24 = 10/100 ports [port 23-port 0]</li> </ul>	0
23:0	RSVD	–	Reserved	0

## Multiport Address 2 Register (Page 04h/Addr 20h–25h)

*Table 121: Multiport Address 2 Register (Page 04h: Address 20h–25h)*

<b>Bit</b>	<b>Name</b>	<b>R/W</b>	<b>Description</b>	<b>Default</b>
47:0	MPORT_ADDR_2	R/W	Multiport Address 2. Allows a frames with a matching DA to this address to be forwarded to any programmable group of ports on the chip, as defined in the bit map in the Multiport Vector 2 register. Must be enabled using the MPORT_ADDR_EN bit in the Global ARL Configuration register.	00-00-00-00-00-00h

## Multiport Vector 2 Register (Page 04h/Addr 28h–2Fh)

*Table 122: Multiport Vector 2 Register (Page 04h: Address 28h–2Fh)*

<b>Bit</b>	<b>Name</b>	<b>R/W</b>	<b>Description</b>	<b>Default</b>
63:51	Reserved	RO	Reserved. Write default. Ignore on read.	0

**Table 122: Multiport Vector 2 Register (Page 04h: Address 28h–2Fh)**

Bit	Name	R/W	Description	Default
50:24	MPORT_VCTR_2 [50:24]	R/W	Multiport Vector 2. A 27-bit mask corresponding to the physical ports on the chip. A frame with a DA matching the content of the Multiport Address 2 register is forwarded to each port with a bit set in the Multiport Vector 2 bit map. <ul style="list-style-type: none"> <li>• Bit 50 = GigaPort G1</li> <li>• Bit 49 = GigaPort G0</li> <li>• Bit 48 = IMP</li> <li>• Bits 47:24 = 10/100 ports [port 23–port 0]</li> </ul>	0
23:0	RSVD	–	Reserved	0

## Page 05h: ARL Access Registers

**Table 123: ARL Access Registers (Page 05h)**

Address	Bits	Register Name
00h	8	<a href="#">“ARL Read/Write Control Register (Page 05h/Addr 00h)” on page 213</a>
01h–0Fh	Reserved	
02h–07h	48	<a href="#">“MAC Address Index Register (Page 05h/Addr 02h–07h)” on page 213</a>
08h–09h	16	<a href="#">“VID Table Index Register (Page 05h/Addr 08h–09h)” on page 214</a>
0Ah–0Fh	Reserved	
10h–17h	64	<a href="#">“ARL Entry 0 Register, for Multicast Address (Page 05h/Addr 10h–17h)” on page 215</a>
18h–19h	64	<a href="#">“ARL Entry 1 Register, for Unicast Address (Page 05h/Addr 18h–1Fh)” on page 217</a>
1Ah–1Fh	Reserved	
20h–21h	16	<a href="#">“VID Entry 0 Register (Page 05h/Addr 20h–21h)” on page 218</a>
22h–27h	Reserved	
28h–2Fh	16	<a href="#">“VID Entry 1 Register (Page 05h/Addr 28h–29h)” on page 219</a>
30h–37h	16	<a href="#">“Multitable Index Register (Page 05h/Addr 30h–31h)” on page 219</a>
38h–3Fh	64	<a href="#">“Multitable Data 0 Register (Page 05h/Addr 38h–3Fh)” on page 221</a>
40h–47h	64	<a href="#">“Multitable Data 1 Register (Page 05h/Addr 40h–47h)” on page 222</a>
48h–4Fh	64	<a href="#">“Multitable Data 2 Register (Page 05h/Addr 48h–4Fh)” on page 225</a>
50h	8	<a href="#">“ARL Search Control Register (Page 05h/Addr 50h)” on page 226</a>
51h	Reserved	
52h–53h	16	<a href="#">“ARL Search Address Register (Page 05h/Addr 52h–53h)” on page 226</a>
54h–5Bh	64	<a href="#">“ARL Search Result MAC Register (Page 05h/Addr 54h–5Bh)” on page 227</a>

**Table 123: ARL Access Registers (Page 05h)**

<b>Address</b>	<b>Bits</b>	<b>Register Name</b>
5Ch–5Dh	16	<a href="#">“ARL Search Result VID Register (Page 05h/Addr 5Ch–5Dh)” on page 228</a>
5Eh–EFh	Reserved	
F0h–F7h	–	SPI Data I/O[0:7]
F8h–FDh	Reserved	
FEh	–	SPI Status
FFh	8	Page Register

Broadcom Confidential

## ARL Read/Write Control Register (Page 05h/Addr 00h)

**Table 124: ARL Read/Write Control Register (Page 05h: Address 00h)**

Bit	Name	R/W	Description	Default
7	START/DONE	R/W (SC)	Start/Done Command. Write as 1 to initiate a read or write command after first loading the MAC_ADDR_INDX register with the MAC address for which the ARL entry is to be read or written. The BCM53242M resets the bit to indicate that a write or read operation has completed, and data from the bin entry is available in ARL Entry.	0
6:4	Reserved	RO	Reserved. Write default. Ignore on read.	0
3:1	TBL_INDEX	R/W	Index to Tables <ul style="list-style-type: none"> <li>• 111= Flow to VLAN Table</li> <li>• 110 = Protocol to VLAN Table</li> <li>• 101 = MAC to VLAN Table</li> <li>• 100 = VLAN to VLAN Table</li> <li>• 011 = Multiple Spanning Tree Table</li> <li>• 010 = Multicast Table</li> <li>• 001 = VLAN Table</li> <li>• 000 = ARL Table</li> </ul>	0
0	TBL_R/W	R/W	Table Read/Write. <ul style="list-style-type: none"> <li>• 1 = Read.</li> <li>• 0 = Write.</li> </ul>	0

## MAC Address Index Register (Page 05h/Addr 02h–07h)

**Table 125: MAC Address Index Register (Page 05h: Address 02h–07h)**

Bit	Name	R/W	Description	Default
47:0	MAC_ADDR_INDX	R/W	MAC Address Index. The MAC address for which status is to be read or written. By writing the 48 bit SA or DA address, and initiating a read command, the complete ARL bin location is returned in the ARL Entry location. The entry is 64 bits wide. Initiating a write command writes the contents of ARL Entry to the specified bin location and overwrites the current contents of the bin, regardless of the Valid bit status in each entry. <b>Note:</b> MAC_ADDR_INDX is also used as the index to the MAC to VLAN table.	00-00-00-00-00-00h

## VID Table Index Register (Page 05h/Addr 08h–09h)

**Table 126: VID Table Index Register (Page 05h: Address 08h–09h)**

Bit	Name	R/W	Description	Default
15:12	Reserved	RO	Reserved. Write default. Ignore on read.	0
11:0	VID_TBL_INDX	R/W	VLAN Table Index. When 802.1Q is enabled and VID_MAC Control, bits[6:5] of 802.1Q VLAN Control 0 register are asserted (Page 34h, Addr 00h), VID_TBL_INDX is used with the MAC_ADDR_INDX, defined in the MAC Address Index register, to form the hash index for which status is to be read or written.	000h

## ARL Entry 0 Register, for Unicast Address (Page 05h/Addr 10h–17h)

**Table 127: ARL Entry 0 Register, for Unicast Address Register (Page 05h: Address 10h–17h)**

Bit	Name	R/W	Description	Default
63	VALID	R/W	Valid. Set to indicate that a valid MAC address is stored in the MACADDR field, and that the entry has not aged out or been freed by the management processor. Reset when an entry is empty, the address has been aged out by the internal aging process, or the external management processor has invalidated the entry. Automatic learning takes place if an address location is not valid and has not been marked as static.	0
62	STATIC	R/W	Static. Set to indicate that the entry is controlled by the external management processor, and automatic learning and aging of the entry does not take place. When cleared, the internal learning and aging process controls the validity of the entry.	0
61:60	CON[1:0]	R/W	ARL mode control. These bits select the ARL mode, which determines the forwarding decision. <ul style="list-style-type: none"> <li>11 = Forward to destination port specified by ARL and also send to IMP. (Suggest to also set bit 62).</li> <li>10 = Drop if MAC_SA match. (Suggest to also set bit 62).</li> <li>01 = Drop if MAC_DA match. (Suggest to also set bit 62).</li> <li>00 = Normal ARL function. Forward to destination port specified by ARL.</li> </ul>	0

**Table 127: ARL Entry 0 Register, for Unicast Address Register (Page 05h: Address 10h–17h) (Cont.)**

Bit	Name	R/W	Description	Default
59	AGE0	R/W	Age Set to indicate that an address entry has been learned or accessed. Reset by the internal aging algorithm. If the internal aging process detects a Valid entry has remained unused for the period set by the AGE_TIME, and the entry has not been marked as Static, the entry has the Valid bit cleared. The Age bit is ignored if the entry has been marked as Static.	0
58:54	Reserved	R/W	Write as default. Ignore on read	0
53:48	PORTID[5:0]	R/W	Port Identification (for unicast address) The port number which identifies where the station with unique MACADDR is connected. <ul style="list-style-type: none"> <li>• 50 = GigaPort G1</li> <li>• 49 = GigaPort G0</li> <li>• 48 = IMP</li> <li>• 24 ~ 47 = 10/100 ports [port 0–port 23]</li> <li>• 0 ~ 23 = Reserved</li> </ul>	0
47:0	MACADDR	R/W	MAC Address	0

## ARL Entry 0 Register, for Multicast Address (Page 05h/Addr 10h–17h)

**Table 128: ARL Entry, for Multicast Address Register (Page 05h: Address 10h–17h)**

Bit	Name	R/W	Description	Default
63	VALID	R/W	Valid. Set to indicate that a valid MAC address is stored in the MACADDR field, and that the entry has not aged out or been freed by the management processor. Reset when an entry is empty, the address has been aged out by the internal aging process, or the external management processor has invalidated the entry. Automatic learning takes place if an address location is not valid and has not been marked as static.	0
62	STATIC	R/W	Static. Set to indicate that the entry is controlled by the external management processor, and automatic learning and aging of the entry does not take place. When cleared, the internal learning and aging process controls the validity of the entry.	0

**Table 128: ARL Entry, for Multicast Address Register (Page 05h: Address 10h–17h) (Cont.)**

<b>Bit</b>	<b>Name</b>	<b>R/W</b>	<b>Description</b>	<b>Default</b>
61:60	CON[1:0]	R/W	<p>ARL mode control.</p> <p>These bits select the ARL mode, which determines the forwarding decision.</p> <ul style="list-style-type: none"> <li>• 11 = Forward to destination port specified by ARL and also send to IMP. (Suggest to also set bit 62).</li> <li>• 10 = Drop if MAC_SA match. (Suggest to also set bit 62).</li> <li>• 01 = Drop if MAC_DA match. (Suggest to also set bit 62).</li> <li>• 00 = Normal ARL function. Forward to destination port specified by ARL.</li> </ul>	0
59:48	MC_Index 0	R/W	<p>Multicast Index 0</p> <p>12-bit index to 4K entry Multicast Vector table.</p>	0
47:0	MACADDR	R/W	MAC Address	0



## ARL Entry 1 Register, for Unicast Address (Page 05h/Addr 18h–1Fh)

**Table 129: ARL Entry Register, for Unicast Address (Page 05h: Address 18h–1Fh)**

Bit	Name	R/W	Description	Default
63	VALID	R/W	Valid. Set to indicate that a valid MAC address is stored in the MACADDR field, and that the entry has not aged out or been freed by the management processor. Reset when an entry is empty, the address has been aged out by the internal aging process, or the external management processor has invalidated the entry. Automatic learning takes place if an address location is not valid and has not been marked as static.	0
62	STATIC	R/W	Static. Set to indicate that the entry is controlled by the external management processor, and automatic learning and aging of the entry does not take place. When cleared, the internal learning and aging process controls the validity of the entry.	0
61:60	CON[1:0]	R/W	ARL mode control. These bits select the ARL mode, which determines the forwarding decision. <ul style="list-style-type: none"> <li>11 = Forward to destination port specified by ARL and also send to IMP. (Suggest to also set bit 62).</li> <li>10 = Drop if MAC_SA match. (Suggest to also set bit 62).</li> <li>01 = Drop if MAC_DA match. (Suggest to also set bit 62).</li> <li>00 = Normal ARL function. Forward to destination port specified by ARL.</li> </ul>	0
59	AGE0	R/W	Age. Set to indicate that an address entry has been learned or accessed. Reset by the internal aging algorithm. If the internal aging process detects a Valid entry has remained unused for the period set by the AGE_TIME, and the entry has not been marked as Static, the entry has the Valid bit cleared. The Age bit is ignored if the entry has been marked as Static.	0
58:54	Reserved	R/W	Write as default. Ignore on read	0
53:48	PORTID[5:0]	R/W	Port Identification. The port number which identifies where the station with unique MACADDR is connected. <ul style="list-style-type: none"> <li>50 = GigaPort G1</li> <li>49 = GigaPort G0</li> <li>48 = IMP</li> <li>24 ~ 47 = 10/100 ports [port 0–port 23]</li> <li>0 ~ 23 = Reserved</li> </ul>	0
47:0	MACADDR	R/W	MAC Address.	0

## ARL Entry 1 Register, for Multicast Address (Page 05h/Addr 18h–1Fh)

**Table 130: ARL Entry Register, for Multicast Address (Page 05h: Address 18h–1Fh)**

Bit	Name	R/W	Description	Default
63	VALID	R/W	Valid. Set to indicate that a valid MAC address is stored in the MACADDR field, and that the entry has not aged out or been freed by the management processor. Reset when an entry is empty, the address has been aged out by the internal aging process, or the external management processor has invalidated the entry. Automatic learning takes place if an address location is not valid and has not been marked as static.	0
62	STATIC	R/W	Static. Set to indicate that the entry is controlled by the external management processor, and automatic learning and aging of the entry does not take place. When cleared, the internal learning and aging process controls the validity of the entry.	0
61:60	CON[1:0]	R/W	ARL mode control. These bits select the ARL mode, which determines the forwarding decision. <ul style="list-style-type: none"> <li>11 = Forward to destination port specified by ARL and also send to IMP. (Suggest to also set bit 62).</li> <li>10 = Drop if MAC_SA match. (Suggest to also set bit 62).</li> <li>01 = Drop if MAC_DA match. (Suggest to also set bit 62).</li> <li>00 = Normal ARL function. Forward to destination port specified by ARL.</li> </ul>	0
59:48	MC_Index 1	R/W	Multicast Index 1 12-bit index to 4K entry Multicast Vector table.	0
47:0	MACADDR	R/W	MAC Address.	0

## VID Entry 0 Register (Page 05h/Addr 20h–21h)

**Table 131: VID Entry Register (Page 05h: Address 20h–21h)**

Bit	Name	R/W	Description	Default
15	RSVD	RO	Reserved. Write default. Ignore on read.	0
14:12	USER_DEF	RO	User Defined Field These are user defined bits. These bits are also written into the ARL table along with ARL_VID_ENTRY.	0
11:0	ARL_VID_Entry	R/W	ARL VID Entry. The VID field to be either read from or written to the ARL table entry. The VID is a don't-care field when 802.1Q is disabled.	0

## VID Entry 1 Register (Page 05h/Addr 28h–29h)

*Table 132: VID Entry Register (Page 05h: Address 28h–29h)*

<i>Bit</i>	<i>Name</i>	<i>R/W</i>	<i>Description</i>	<i>Default</i>
15	RSVD	RO	Reserved. Write default. Ignore on read.	0
14:12	USER_DEF	RO	User Defined Field These are user defined bits. These bits are also written into the ARL table along with ARL_VID_ENTRY.	0
11:0	ARL_VID_Entry	R/W	ARL VID Entry. The VID field to be either read from or written to the ARL table entry. The VID is a don't-care field when 802.1Q is disabled.	0

## Multitable Index Register (Page 05h/Addr 30h–31h)

*Table 133: Multitable Index Register (Page 05h: Address 30h–31h)*

<i>Bit</i>	<i>Name</i>	<i>R/W</i>	<i>Description</i>	<i>Default</i>
15:12	RSVD	RO	Reserved. Write default. Ignore on read.	0

**Table 133: Multitable Index Register (Page 05h: Address 30h–31h)**

Bit	Name	R/W	Description	Default
11:0	MULTI_TBL_INDEX	R/W	<p>Multitable Index.</p> <p>When TBL_INDEX, bits[3:1] of “<a href="#">ARL Read/Write Control Register (Page 05h/Addr 00h)</a>” on <a href="#">page 213</a>) are set.</p> <ul style="list-style-type: none"> <li>• 111 = Access to Flow to VLAN Table: <ul style="list-style-type: none"> <li>– MULTI_TBL_INDEX[11:9] is ignored and should be zero.</li> <li>– MULTI_TBL_INDEX[8:0] is then used as the Flow to VLAN Table index and consisted of NEW_FLOW_INDXX (4 bits) + Egress Port ID (5 bits). NEW_FLOW_INDXX is defined as bits[28:25] in “<a href="#">CFP Action Policy Data Register (Page 20h/Addr 70h–75h)</a>” on <a href="#">page 265</a>).</li> </ul> </li> <li>• 110 = Access to Protocol to VLAN Table: <ul style="list-style-type: none"> <li>– MULTI_TBL_INDEX[11:4] is ignored and should be zero.</li> <li>– MULTI_TBL_INDEX[3:0] is then used as the Protocol to VLAN Table index.</li> </ul> </li> <li>• 101 = Access to MAC to VLAN Table: <ul style="list-style-type: none"> <li>– MULTI_TBL_INDEX[11:0] is reserved and should be ignored.</li> </ul> </li> <li>• 100 = Access to VLAN to VLAN Table: <ul style="list-style-type: none"> <li>– MULTI_TBL_INDEX[11:0] is then used as the VLAN to VLAN Table index.</li> </ul> </li> </ul> <p><b>Note:</b> MULTI_TBL_INDEX[11:0] is defined as the VID embedded in the ingress packet.</p> <ul style="list-style-type: none"> <li>• 011 = Access to Multiple Spanning Tree Table: <ul style="list-style-type: none"> <li>– MULTI_TBL_INDEX[11:8] is ignored and should be zero.</li> <li>– MULTI_TBL_INDEX[7:0] is then used as the Multiple Spanning Tree Table index.</li> </ul> </li> <li>• 010 = Access to Multicast Table: <ul style="list-style-type: none"> <li>– MULTI_TBL_INDEX[11:0] is then used as the Multicast Table index.</li> </ul> </li> <li>• 001 = Access to VLAN Table: <ul style="list-style-type: none"> <li>– MULTI_TBL_INDEX[11:0] is then used as the VLAN Table index.</li> </ul> </li> <li>• 000 = Access to ARL Table: <ul style="list-style-type: none"> <li>– MULTI_TBL_INDEX[11:0] is then used as the ARL Table index.</li> </ul> </li> </ul>	0

## Multitable Data 0 Register (Page 05h/Addr 38h–3Fh)

**Table 134: Multitable Data 0 Register (Page 05h: Address 38h–3Fh)**

<b>Bit</b>	<b>Name</b>	<b>R/W</b>	<b>Description</b>	<b>Default</b>
63:0	TBL_DATA_0	R/W	<p>When Flow to VLAN Table is accessed,</p> <ul style="list-style-type: none"> <li>TBL_DATA_0 [63:12] : reserved</li> <li>TBL_DATA_0 [11:0] : VID</li> </ul> <p>When Protocol to VLAN Table is accessed,</p> <ul style="list-style-type: none"> <li>TBL_DATA_0 [63:32]: reserved</li> <li>TBL_DATA_0 [31]: Valid</li> <li>TBL_DATA_0 [30:28]: Priority for Protocol base.</li> <li>TBL_DATA_0 [27:16]: VID</li> <li>TBL_DATA_0 [15:0]: Ether Type</li> </ul> <p>When MAC to VLAN Table is accessed,</p> <ul style="list-style-type: none"> <li>TBL_DATA_0 [63]: Valid_0</li> <li>TBL_DATA_0 [62:60]: PRI_0, Priority for MAC SA base</li> <li>TBL_DATA_0 [59:48]: VID_0</li> <li>TBL_DATA_0 [47:0]: MAC address</li> </ul> <p>When VLAN to VLAN Table is accessed,</p> <ul style="list-style-type: none"> <li>TBL_DATA_0 [63:13]: reserved</li> <li>TBL_DATA_0 [12]: <ul style="list-style-type: none"> <li>1: mapping mode</li> <li>0: transparent mode</li> </ul> </li> <li>TBL_DATA_0 [11:0]: New VID</li> </ul> <p>When Multiple Spanning Tree Table is accessed,</p> <ul style="list-style-type: none"> <li>TBL_DATA_0 [63:0]: reserved</li> </ul> <p>When Multicast Table is accessed,</p> <ul style="list-style-type: none"> <li>TBL_DATA_0 [63:53]: reserved</li> <li>TBL_DATA_0 [52:24]: Multicast Forwarding vector</li> <li>TBL_DATA_0 [23:0]: reserved</li> </ul> <p>When VLAN Table is accessed,</p> <ul style="list-style-type: none"> <li>TBL_DATA_0 [63:53]: reserved</li> <li>TBL_DATA_0 [52:24]: VLAN Table Forwarding vector</li> <li>TBL_DATA_0 [23:0]: reserved</li> </ul>	0

## Multitable Data 1 Register (Page 05h/Addr 40h–47h)

Broadcom Confidential

Broadcom Confidential

**Table 135: Multitable Data 1 Register (Page 05h: Address 40h–47h)**

Bit	Name	R/W	Description	Default
63:0	TBL_DATA_1	R/W	<p>When Flow to VLAN Table is accessed,</p> <ul style="list-style-type: none"> <li>TBL_DATA_1 [63:0]: reserved</li> </ul> <p>When Protocol to VLAN Table is accessed,</p> <ul style="list-style-type: none"> <li>TBL_DATA_1 [63:0]: reserved</li> </ul> <p>When MAC to VLAN Table is accessed,</p> <ul style="list-style-type: none"> <li>TBL_DATA_1 [63]: Valid_1</li> <li>TBL_DATA_1 [62:60]: PRI_1, Priority for MAC base (SA)</li> <li>TBL_DATA_1 [59:48]: VID_1</li> <li>TBL_DATA_1 [47:0]: MAC-1, MAC address</li> </ul> <p>When VLAN to VLAN Table is accessed,</p> <ul style="list-style-type: none"> <li>TBL_DATA_1 [63:0]: reserved</li> </ul> <p>When Multiple Spanning Tree Table is accessed,</p> <ul style="list-style-type: none"> <li>TBL_DATA_1 [63:60]: reserved</li> <li>TBL_DATA_1 [59:57]: Multiple Spanning tree state for port 39</li> <li>TBL_DATA_1 [56:54]: Multiple Spanning tree state for port 38</li> <li>TBL_DATA_1 [53:51]: Multiple Spanning tree state for port 37</li> <li>.....</li> <li>TBL_DATA_1 [17:15]: Multiple Spanning tree state for port 25</li> <li>TBL_DATA_1 [14:12]: Multiple Spanning tree state for port 24</li> </ul> <p><b>Note:</b> TBL_DATA [3bits]</p> <ul style="list-style-type: none"> <li>– 000 = no spanning tree</li> <li>– 001 = disable state</li> <li>– 010 = blocking state</li> <li>– 011 = listening state</li> <li>– 000 = learning state</li> <li>– 101 = forwarding state</li> <li>– 110,111 = reserved</li> </ul> <p>When Multicast Table is accessed,</p> <ul style="list-style-type: none"> <li>TBL_DATA_1 [63:0]: reserved</li> </ul> <p>When VLAN Table is accessed,</p> <ul style="list-style-type: none"> <li>TBL_DATA_1 [63:53]: reserved</li> <li>TBL_DATA_1 [52:24]: VLAN Table Untag vector</li> <li>TBL_DATA_1 [23:0]: reserved</li> </ul>	0



## Multitable Data 2 Register (Page 05h/Addr 48h–4Fh)

**Table 136: Multitable Data 2 Register (Page 05h: Address 48h–4Fh)**

Bit	Name	R/W	Description	Default
63:0	TBL_DATA_2	R/W	<p>When Flow to VLAN Table is accessed,</p> <ul style="list-style-type: none"> <li>TBL_DATA_2 [63:0]: reserved</li> </ul> <p>When Protocol to VLAN Table is accessed,</p> <ul style="list-style-type: none"> <li>TBL_DATA_2 [63:0]: reserved</li> </ul> <p>When MAC to VLAN Table is accessed,</p> <ul style="list-style-type: none"> <li>TBL_DATA_2 [63:0]: reserved</li> </ul> <p>When VLAN to VLAN Table is accessed,</p> <ul style="list-style-type: none"> <li>TBL_DATA_2 [63:0]: reserved</li> </ul> <p>When Multiple Spanning Tree Table is accessed,</p> <ul style="list-style-type: none"> <li>TBL_DATA_2 [63:39]: reserved</li> <li>TBL_DATA_2 [38:36]: Multiple Spanning tree state for port 52</li> <li>TBL_DATA_2 [35:33]: Multiple Spanning tree state for port 51</li> <li>.....</li> <li>TBL_DATA_2 [2:0]: Multiple Spanning tree state for port 40</li> </ul> <p><b>Note:</b> TBL_DATA[3bits]</p> <ul style="list-style-type: none"> <li>– 000 = no spanning tree</li> <li>– 001 = disable state</li> <li>– 010 = blocking state</li> <li>– 011 = listening state</li> <li>– 000 = learning state</li> <li>– 101 = forwarding state</li> <li>– 110,111 = reserved</li> </ul> <p>When Multicast Table is accessed:</p> <ul style="list-style-type: none"> <li>TBL_DATA_2 [63:0]: reserved</li> </ul> <p>When VLAN Table is accessed:</p> <ul style="list-style-type: none"> <li>TBL_DATA_2 [63:9]: reserved</li> <li>TBL_DATA_2 [8]: disable the learning process for packet that matches this VLAN</li> <li>TBL_DATA_2 [7:0]: VLAN Table Spanning ID is for mapping to the MSTP table</li> </ul>	0

## ARL Search Control Register (Page 05h/Addr 50h)

**Table 137: ARL Search Control Register (Page 05h: Address 50h)**

Bit	Name	R/W	Description	Default
7	START/DONE	R/W (SC)	Start/Done Command. Write as 1 to initiate a sequential search of the ARL entries, returning each entry that is currently occupied (Valid = 1 and AGE = 0) in the ARL Search Result register. Reading the ARL Search Result register causes the ARL search to continue. The BCM53242M clears this bit to indicate the entire ARL entry database has been searched.	0
6:1	RSVD	RO	Reserved. Write default. Ignore on read.	0
0	ARL_SR_VALID	RC	ARL Search Result Valid. Set by the BCM53242M to indicate that an ARL entry is available in the ARL Search Result register. Reset by a host read to the ARL Search Result register, which causes the ARL search process to continue through the ARL entries until the next entry is found with a Valid bit is set.	0

## ARL Search Address Register (Page 05h/Addr 52h–53h)

**Table 138: ARL Search Address Register (Page 05h: Address 52h–53h)**

Bit	Name	R/W	Description	Default
15	ARL_ADDR_VALID	R/W (SC)	ARL Address Valid. Indicates the lower 15 bits of this register contain a valid internal representation of the ARL entry currently being accessed.	0
14:13	RSVD	RO	Reserved. Write default. Ignore on read.	0
12:0	ARL_ADDR	R/W	ARL Address. 15-bit internal representation of the address of the ARL entry currently being accessed by the ARL search routine. This is not a direct address of the ARL location.	0

## ARL Search Result MAC Register (Page 05h/Addr 54h–5Bh)

**Table 139: ARL Search Result Register (Page 05h: Address 54h–5Bh)**

Bit	Name	R/W	Description	Default
63	VALID	RO	Valid. Set to indicate that a valid MAC address is stored in the MACADDR field, and that the entry has not aged out or been freed by the management processor. All entries returned by the ARL Search process has the VALID bit set.	0
62	STATIC	RO	Static. Set to indicate that the entry is controlled by the external management processor, and automatic learning and aging of the entry does not take place. When cleared, the internal learning and aging process controls the validity of the entry. All entries with STATIC bit set are returned by the ARL Search process.	0
61:60	CON[1:0]	RO	ARL mode control. These bits select the ARL mode, which determines the forwarding decision. <ul style="list-style-type: none"> <li>11 = Forward to destination port specified by ARL and also send to IMP. (Suggest to also set bit 62).</li> <li>10 = Drop if MAC_SA match. (Suggest to also set bit 62).</li> <li>01 = Drop if MAC_DA match. (Suggest to also set bit 62).</li> <li>00 = Normal ARL function. Forward to destination port specified by ARL.</li> </ul>	0
59	AGE	RO	Age. Set to indicate that an address entry has been learned or accessed. Reset by the internal aging algorithm. If the internal aging process detects a Valid entry has remained unused for the period set by the AGE_TIME, and the entry has not been marked as Static, the entry has the AGE bit cleared. The Age bit is ignored if the entry has been marked as Static.	0
58:54	RSVD	RO	Reserved. Write default. Ignore on read.	0
53:48	PORTID[5:0]	RO	Port Identification. The port number which identifies where the station with unique MACADDR is connected. <ul style="list-style-type: none"> <li>50 = GigaPort G1</li> <li>49 = GigaPort G0</li> <li>48 = IMP</li> <li>24 ~ 47 = 10/100 ports [port 0–port 23]</li> <li>0 ~ 23 = Reserved</li> </ul>	0
47:0	MACADDR	RO	MAC Address. The unique MAC address of the station occupying this ARL entry.	0

## ARL Search Result VID Register (Page 05h/Addr 5Ch–5Dh)

*Table 140: ARL Search Result VID Register (Page 05h: Address 5Ch–5Dh)*

<i>Bit</i>	<i>Name</i>	<i>R/W</i>	<i>Description</i>	<i>Default</i>
15	RSVD	RO	Reserved. Write default. Ignore on read.	0
14:12	USER_DEF	RO	User Defined Field These are user defined bits. These bits are also written into the ARL table along with ARL_VID_ENTRY.	0
11:0	VID	RO	VID search result.	0



**Note:** If 802.1Q is enabled, Broadcom recommends to read the ARL Search Result VID register first, then read the ARL Search Result MAC register.

## Page 0Ah: Priority Queue Control Registers

**Table 141: Priority Control Registers (Page 0Ah)**

Address	Bits	Description
00h-01h	16	Flow Control Diagnostic Register (PAGE 0AH/ADDR 00H-02H)
02h-05h	Reserved	
06h-07h	16	QUEUE 0 100 TX THRESHOLD CONTROL 1 REGISTER (PAGE 0AH/ADDR 06H-07H)
08h-09h	16	QUEUE 0 100 TX THRESHOLD CONTROL 2 REGISTER (PAGE 0AH/ADDR 08H-09H)
0Ah-0Dh	Reserved	
0Eh-0Fh	16	GLOBAL THRESHOLD CONTROL 1 REGISTER (PAGE 0AH/ADDR 0EH-0FH)
10h-11h	16	GLOBAL THRESHOLD CONTROL 2 REGISTER (PAGE 0AH/ADDR 10H-11H)
12h-13h	16	TRANSMIT QUEUE THRESHOLD CONTROL REGISTER (PAGE 0AH/ADDR 12H-13H)
14h-1Bh	Reserved	–
1Ch-1Dh	16	FLOW CONTROL STATUS 2 REGISTER (PAGE 0AH/ADDR 1CH-1DH)
1Eh-1Fh	16	FLOW CONTROL STATUS 3 REGISTER (PAGE 0AH/ADDR 1EH-1FH)
20h-21h	16	FLOW CONTROL STATUS 4 REGISTER (PAGE 0AH/ADDR 20H-21H)
22h-23h	16	FLOW CONTROL STATUS 5 REGISTER (PAGE 0AH/ADDR 22H-23H)
24h-25h	Reserved	
26h-27h	16	FLOW CONTROL STATUS 7 REGISTER (PAGE 0AH/ADDR 26H-27H)
28h-29h	Reserved	
2Ah-2Bh	16	FLOW CONTROL STATUS 9 REGISTER (PAGE 0AH/ADDR 2AH-2BH)
2Ch-2Dh	16	FLOW CONTROL STATUS 10 REGISTER (PAGE 0AH/ADDR 2CH-2DH)
2Eh-2Fh	16	FLOW CONTROL STATUS 11 REGISTER (PAGE 0AH/ADDR 2EH-2FH)
30h-31h	16	GLOBAL OPTION CONTROL REGISTER (PAGE 0AH/ADDR 30H-31H)
32h-33h	16	CPU/MII THRESHOLD CONTROL REGISTER (PAGE 0AH/ADDR 32H-33H)
34h-35h	16	PRE-QUEUE TX DROP CONTROL REGISTER (PAGE 0AH/ADDR 34H-35H)
36h-37h	16	MON FLOW CONTROL REG BUS REGISTER (PAGE 0AH/ADDR 36H-37H)
38h-3Bh	Reserved	
3Ch-3Dh	16	FLOW CONTROL STATUS 12 REGISTER (PAGE 0AH/ADDR 3CH-3DH)
3Eh-49h	Reserved	
4Ah-4Bh	16	MISC TX FLOW CONTROL REGISTER (PAGE 0AH/ADDR 4AH-4BH)
4Ch-4Fh	Reserved	
50h-51h	16	QUEUE CONGESTION STATUS 0 REGISTER (PAGE 0AH/ADDR 50H-51H)
52h-53h	16	QUEUE CONGESTION STATUS 1 REGISTER (PAGE 0AH/ADDR 52H-53H)
54h-55h	16	QUEUE CONGESTION STATUS 2 REGISTER (PAGE 0AH/ADDR 54H-55H)
56h-57h	Reserved	

**Table 141: Priority Control Registers (Page 0Ah) (Cont.)**

<b>Address</b>	<b>Bits</b>	<b>Description</b>
58h-59h	16	QUEUE CONGESTION STATUS 3 REGISTER (PAGE 0AH/ADDR 58H-59H)
5Ah-5Bh	16	QUEUE CONGESTION STATUS 4 REGISTER (PAGE 0AH/ADDR 5AH-5BH)
5Ch-5Dh	16	QUEUE CONGESTION STATUS 5 REGISTER (PAGE 0AH/ADDR 5CH-5DH)
5Eh-63h	Reserved	
64h-65h	16	QUEUE 0 TXDSC CONTROL REGISTER (PAGE 0AH/ADDR 64H-65H)
66h-69h	Reserved	
6Ah-6Bh	16	QUEUE 1 100BT THRESHOLD CONTROL 1 REGISTER (PAGE 0AH/ADDR 6AH-6BH)
6Ch-6Dh	16	QUEUE 1 100BT THRESHOLD CONTROL 2 REGISTER (PAGE 0AH/ADDR 6CH-6DH)
6Eh-71h	Reserved	–
72h-73h	16	QUEUE 1 TXDSC CONTROL REGISTER (PAGE 0AH/ADDR 72H-73H)
74h-77h	Reserved	
78h-79h	16	QUEUE 2 100TX THRESHOLD CONTROL 1 REGISTER (PAGE 0AH/ADDR 78H-79H)
7Ah-7Bh	16	QUEUE 2 100TX THRESHOLD CONTROL 2 REGISTER (PAGE 0AH/ADDR 7AH-7BH)
7Ch-7Fh	Reserved	–
80h-81h	16	QUEUE 2 TXDSC CONTROL REGISTER (PAGE 0AH/ADDR 80H-81H)
82h-85h	Reserved	–
86h-87h	16	QUEUE 3 100TX THRESHOLD CONTROL 1 REGISTER (PAGE 0AH/ADDR 86H-87H)
88h-89h	16	QUEUE 3 100TX THRESHOLD CONTROL 2 REGISTER (PAGE 0AH/ADDR 88H-89H)
8Ah-8Bh	16	RX Base BUFFER NUMBER REGISTER (PAGE 0AH/ADDR 8AH-8BH)
8Ch-8Dh	Reserved	
8Eh-8Fh	16	QUEUE 3 TXDSC CONTROL REGISTER (PAGE 0AH/ADDR 8EH-8FH)
90h-91h	16	RESERVED BUFFER NUMBER REGISTER (PAGE 0AH/ADDR 90H-91H)
92h-93h	16	RECEIVED Base FLOW CONTROL REGISTER (PAGE 0AH/ADDR 92H-93H)
94h-95h	16	DLF THRESHOLD DROP REGISTER (PAGE 0AH/ADDR 94H-95H)
96h-97h	16	BROADCAST THRESHOLD DROP REGISTER (PAGE 0AH/ADDR 96H-97H)
98h-9Fh	Reserved	–
A0h-A1h	16	LAN TO IMP UNICAST CONTROL REGISTER (PAGE 0AH/ADDR A0H-A1H)
A2h-A3h	16	LAN TO IMP MULTICAST CONTROL 1 REGISTER (PAGE 0AH/ADDR A2H-A3H)
A4h-A5h	16	LAN TO IMP MULTICAST CONTROL 2 REGISTER (PAGE 0AH/ADDR A4H-A5H)
A6h-AFh	Reserved	–
B0h-B1h	16	IMP TO LAN CONTROL 1 REGISTER (PAGE 0AH/ADDR B0H-B1H)
B2h-B3h	16	IMP TO LAN CONTROL 2 REGISTER (PAGE 0AH/ADDR B2H-B3H)

**Table 141: Priority Control Registers (Page 0Ah) (Cont.)**

<b>Address</b>	<b>Bits</b>	<b>Description</b>
B4h-BFh	Reserved	–
C0h-C1h	16	QUEUE 1 TOTAL THRESHOLD CONTROL 1 REGISTER (PAGE 0AH/ADDR C0H-C1H)
C2h-C3h	16	QUEUE 1 TOTAL THRESHOLD CONTROL 2 REGISTER (PAGE 0AH/ADDR C2H-C3H)
C4h-C5h	16	QUEUE 2 TOTAL THRESHOLD CONTROL 1 REGISTER (PAGE 0AH/ADDR C4H-C5H)
C6h-C7h	16	QUEUE 2 TOTAL THRESHOLD CONTROL 2 REGISTER (PAGE 0AH/ADDR C6H-C7H)
C8h-C9h	16	QUEUE 3 TOTAL THRESHOLD CONTROL 1 REGISTER (PAGE 0AH/ADDR C8H-C9H)
CAh-CBh	16	QUEUE 3 TOTAL THRESHOLD CONTROL 2 REGISTER (PAGE 0AH/ADDR CAH-CBH)
CCh-CFh	Reserved	–
D0h-D1h	16	QUEUE 1 TOTAL BC/DLF DROP THRESHOLD CONTROL REGISTER (PAGE 0AH/ADDR D0HD1H)
D2h-D3h	16	QUEUE 2 TOTAL BC/DLF DROP THRESHOLD CONTROL REGISTER (PAGE 0AH/ADDR D2HD3H)
D4h-D5h	16	QUEUE 3 TOTAL BC/DLF DROP THRESHOLD CONTROL REGISTER (PAGE 0AH/ADDR D4HD5H)

## Flow Control Diagnostic Register (Page 0Ah/Addr 00h–01h)

**Table 142: Flow Control Diagnostic Register (Page 0Ah: Address 00h–01h)**

Bit	Name	R/W	Description	Default
15:14	RSVD	RO	Reserved. Write default. Ignore on read.	0
13:12	DIAG_HIST_SEL	R/W	Select which histogram value to report.	0
11:8	DIAG_TXQ_SEL	R/W	Select which Tx Queue to be monitored.	0
7:6	FC_PRI-Q_SEL	R/W	<ul style="list-style-type: none"> <li>• 11 = Highest Queue</li> <li>• 10 = 2nd Queue</li> <li>• 01 = 1st Queue</li> <li>• 00 = Lowest Queue</li> </ul>	0
5:0	DIAG_FC_PORT	R/W	Diagnose Port Flow Control. These bits select which port to monitor. <ul style="list-style-type: none"> <li>• 50 = Port number for GigaPort G1</li> <li>• 49 = Port number for GigaPort G0</li> <li>• 48 = Port number for IMP</li> <li>• 24~47 = Port numbers for 10/100 ports [port 0-port 23]</li> </ul>	0x18

## Queue 0 100 TX Threshold Control 1 Register (Page 0Ah/Addr 06h–07h)

**Table 143: Queue 0 100 Tx Threshold Control 1 Register (Page 0Ah: Address 06h–07h)**

Bit	Name	R/W	Description	Default
15:8	Q0_BT100_HYST_THRS	RO	Q0 Unpause Threshold Regulates the transmission of the TXQ based flow control unpause frame. Under mixed-speed mode, when Q0 reaches the pause condition and the number of pointers queued up in the corresponding TXQ (Q0) drops below this threshold, an unpause frame is dispatched. The effective threshold is the default value multiplied by 8.	13h
7:0	Q0_BT100_PAUS_THRS	R/W	Q0 Pause Threshold Regulates the transmission of the TXQ based flow control pause frame. Under mixed-speed mode, when the number of pointers queued up in the corresponding TXQ (Q0) exceeds this threshold, a pause frame is dispatched. The effective threshold is the default value multiplied by 8.	1Ch

**Note:** When QoS is disabled, this register is ignored.



## Queue 0 100 TX Threshold Control 2 Register (Page 0Ah/Addr 08h–09h)

**Table 144: Queue 0 100 Tx Threshold Control 2 Register (Page 0Ah: Address 08-09h)**

Bit	Name	R/W	Description	Default	Recommended Value
15:8	Q0_BT100_DROP_THRS	RO	Q0 Unicast Drop Threshold Regulates incoming unicast frames. Under mixed-speed mode, when the number of pointers queued up in the corresponding TXQ (Q0) exceeds this threshold, all incoming unicast frames will be dropped. The effective threshold is the default value multiplied by 8.	9Fh	98
7:0	Q0_BT100_DROP_THRS	R/W	Q0 Multicast Drop Threshold Regulates incoming multicast frames. Under mixed-speed mode, when the number of pointers queued up in the corresponding TXQ (Q0) exceeds this threshold, all incoming multicast frames will be dropped. The effective threshold is the default value multiplied by 8.	9Fh	73

**Note:** When QoS is disabled, this register is ignored.

## Global Threshold Control 1 Register (Page 0Ah/Addr 0Eh–0Fh)

**Table 145: Global Threshold Control 1 Register (Page 0Ah: Address 0E-0Fh)**

Bit	Name	R/W	Description	Default	Recommended Value
15:8	FC_GLBL_HYST_THRS	RO	Flow Control Global Unpause Threshold Regulates the global transmission of the TXQ based flow control unpause frame. When the BCM53242M is in a pause condition, and the number of pointers queued up in all the corresponding TXQs drops below this threshold, an unpause frame is dispatched. The effective threshold is the default value multiplied by 8.	61h	44

**Table 145: Global Threshold Control 1 Register (Page 0Ah: Address 0E-0Fh)**

<b>Bit</b>	<b>Name</b>	<b>R/W</b>	<b>Description</b>	<b>Default</b>	<b>Recommended Value</b>
7:0	FC_GLBL_PAUSE_THRD	R/W	Flow Control Global Pause Threshold Regulates the global transmission of the TXQ-based flow control pause frame. When the number of pointers queued up in all the corresponding TXQs exceeds this threshold, a pause frame is dispatched. The effective threshold is the default value multiplied by 8.	85h	7E

## Global Threshold Control 2 Register (Page 0Ah/Addr 10h–11h)

**Table 146: Global Threshold Control 2 Register (Page 0Ah: Address 10-11h)**

<b>Bit</b>	<b>Name</b>	<b>R/W</b>	<b>Description</b>	<b>Default</b>	<b>Recommended Value</b>
15:8	FC_GLBL_DROP_THRS	RO	Flow Control Unicast Global Drop Threshold Regulates global incoming unicast frames. When the total number of pointers queued up in all the corresponding TXQs exceeds this threshold, all incoming unicast frames will be dropped. The effective threshold is the default value multiplied by 8.	B2h	9B
7:0	FC_GLBL_MC_DROP_THRD	R/W	Flow Control Multicast Global Drop Threshold Regulates global incoming multicast frames. When the total number of pointers queued up in all the corresponding TXQs exceeds this threshold, all incoming multicast frames will be dropped. The effective threshold is the default value multiplied by 8.	B2h	7E

## Transmit Queue Threshold Control Register (Page 0Ah/Addr 12h–13h)

**Table 147: Transmit Queue Threshold Control Register (Page 0Ah/Addr 12h–13h)**

<b>Bit</b>	<b>Name</b>	<b>R/W</b>	<b>Description</b>	<b>Default</b>
15:8	RSVD	RO	Reserved	0

**Table 147: Transmit Queue Threshold Control Register (Page 0Ah/Addr 12h–13h)**

Bit	Name	R/W	Description	Default
7:0	TXQ_FULL_THRS	R/W	The threshold used to determine quarter full. It is used together with en_quarter_drop. The effective threshold is this register value times 8. <b>Note:</b> Use of this feature is not recommended.	0x40

## Flow Control Status 2 Register (Page 0Ah/Addr 1Ch-1Dh)

**Table 148: Flow Control Status 2 Register (Page 0Ah/Addr 1Ch-1Dh)**

Bit	Name	R/W	Description	Default
15:8	RSVD	RO	Reserved	0
7:0	MON_TXQ_CNT	RO	TXQ_CNT in the monitored port. <b>Note:</b> For diagnostic purposes only.	0

## Flow Control Status 3 Register (Page 0Ah/Addr 1Eh-1Fh)

**Table 149: Flow Control Status 3 Register (Page 0Ah/Addr 1Eh-1Fh)**

Bit	Name	R/W	Description	Default
15:0	TXQ_FULL_HIST	RO	Txq_full_hist on the monitored ports. <ul style="list-style-type: none"> <li>1 = The corresponding port has reached TXQ_Full condition since the previous read.</li> <li>0 = The corresponding port has not reached the TXQ_Full condition since the previous read.</li> </ul> <b>Note:</b> the port map depends on diag_hist_sel. <ul style="list-style-type: none"> <li>When diag_hist_sel is 1: <ul style="list-style-type: none"> <li>TXQ_FULL_HIST[15:0] =&gt; {5'b0. pt26"pt16}</li> </ul> </li> <li>When diag_hist_sel is 0: <ul style="list-style-type: none"> <li>TXQ_FULL_HIST[15:0] =&gt; {pt15: pt0}</li> </ul> </li> </ul> <b>Note:</b> For diagnostic purposes only.	0

## Flow Control Status 4 Register (Page 0Ah/Addr 20h-21h)

**Table 150: Flow Control Status 4 Register (Page 0Ah/Addr 20h-21h)**

Bit	Name	R/W	Description	Default
15:8	RSVD	RO	Reserved	0
7:0	QoS_TX_DEBUG	RO	Provides debug information on state of the TXQ fsm. 0 <b>Note:</b> For diagnostic purposes only.	0

## Flow Control Status 5 Register (Page 0Ah/Addr 22h-23h)

Table 151: Flow Control Status 5 Register (Page 0Ah/Addr 22h-23h)

Bit	Name	R/W	Description	Default
15:0	DROP_HIST	RO	DROP_HIST on the monitored ports. <ul style="list-style-type: none"> <li>1 = The corresponding port has reached drop condition since the previous read.</li> <li>0 = The corresponding port has not reached the drop condition since the previous read.</li> </ul> <b>Note:</b> the port map depends on diag_hist_sel. <ul style="list-style-type: none"> <li>When diag_hist_sel is 1:               <ul style="list-style-type: none"> <li>DROP_HIST [15:0] =&gt; {5'b0. pt26"pt16}</li> </ul> </li> <li>When diag_hist_sel is 0:               <ul style="list-style-type: none"> <li>DROP_HIST [15:0] =&gt; {pt15: pt0}</li> </ul> </li> </ul> <b>Note:</b> For diagnostic purposes only.	0

## Flow Control Status 7 Register (Page 0Ah/Addr 26h-27h)

Table 152: Flow Control Status 7 Register (Page 0Ah/Addr 26h-27h)

Bit	Name	R/W	Description	Default
15:0	PAUSE_HIST	RO	PAUSE_HIST on the monitored ports. <ul style="list-style-type: none"> <li>1 = The corresponding port has reached pause condition since the previous read.</li> <li>0 = The corresponding port has not reached pause condition since the previous read.</li> </ul> <b>Note:</b> the port map depends on diag_hist_sel. <ul style="list-style-type: none"> <li>When diag_hist_sel is 1:               <ul style="list-style-type: none"> <li>PAUSE_HIST [15:0] =&gt; {5'b0. pt26"pt16}</li> </ul> </li> <li>When diag_hist_sel is 0:               <ul style="list-style-type: none"> <li>PAUSE_HIST [15:0] =&gt; {pt15: pt0}</li> </ul> </li> </ul> <b>Note:</b> For diagnostic purposes only.	0

## Flow Control Status 9 Register (Page 0Ah/Addr 2Ah-2Bh)

Table 153: Flow Control Status 9 Register (Page 0Ah/Addr 2Ah-2Bh)

Bit	Name	R/W	Description	Default
15:10	RSVD	RO	Reserved	0
9:0	PEAK_TOTAL_USED	RO SC	Total pointers used. Tracks the peak total pointers used in the entire system since the last read. This bit is self-clear upon read.	0

**Note:** For diagnostic purposes only.

## Flow Control Status 10 Register (Page 0Ah/Addr 2Ch-2Dh)

Table 154: Flow Control Status 10 Register (Page 0Ah/Addr 2Ch-2Dh)

Bit	Name	R/W	Description	Default
15:10	RSVD	RO	Reserved	0
9:0	PEAK_TXQ_CNT	RO SC	Total TXQ pointers used. Tracks the peak total of TXQ pointers used in the entire system since the last read. This bit is self-clear upon read.	0

**Note:** For diagnostic purposes only.

## Flow Control Status 11 Register (Page 0Ah/Addr 2Eh-2Fh)

Table 155: Flow Control Status 11 Register (Page 0Ah/Addr 2Eh-2Fh)

Bit	Name	R/W	Description	Default
15:10	RSVD	RO	Reserved	0
9:0	PEAK_RXB_CNT	RO SC	Total TXQ pointers used. Based on the mon-flowcon_reg_bus. Tracks the peak TXQ count on the monitored port since the last read. This bit is self-clear upon read.	0

**Note:** For diagnostic purposes only.

## Global Option Control Register (Page 0Ah/Addr 30h–31h)

Table 156: Global Option Control Register (Page 0Ah: Address 30h–31h)

Bit	Name	R/W	Description	Default
15	RSVD	RO	Reserved Write default. Ignore on read.	0
14	EN_DLF_BC_DROP_THRS	R/W	Enable DLF/BC Drop Threshold. Enable local port individual DLF and broadcast drop threshold.	0
13:12	QOS_RSRV_QUOTA_OPT	R/W	Reserved quota <ul style="list-style-type: none"> <li>00: Q3:Q2:Q1:Q0=64:32:16:8 (default value) (suggested setting for QoS mode and flow control off)</li> <li>01: Q3:Q2:Q1:Q0=32:16:8:4</li> <li>10: Q3:Q2:Q1:Q0=14:6:3:2 (for no QoS mode, flow control on)</li> <li>11: all queues are the same as reserve balance (offset 4A, bit[7:0])</li> </ul>	0x3

**Table 156: Global Option Control Register (Page 0Ah: Address 30h–31h) (Cont.)**

Bit	Name	R/W	Description	Default
11	EN_PARKING_PREVENTION	R/W	Enable Parking Prevention <ul style="list-style-type: none"> <li>1 = When enabled, flow control can handle parking condition and prevent unfairness.</li> <li>0 = When disabled, the behavior is same as BCM5324.</li> </ul>	1
10	EN_MCAST_BALANCE	R/W	Enable multicast traffic balance <ul style="list-style-type: none"> <li>1 = use hund_pause and hund_unpause</li> <li>0 = use mcast_drop threshold</li> </ul>	1
9:8	RSVD	RO	Reserved. Write default. Ignore on read.	0
7	AGGRESSIVE_DROP	R/W	Aggressive Drop Mode. <ul style="list-style-type: none"> <li>1 = Enable.</li> <li>0 = Disable.</li> </ul>	0
6:5	RSVD	RO	Reserved. Write default. Ignore on read.	0
4	Enable Multicast Drop	R/W	Enable multicast drop feature due to RX base and TX base flow control scheme.	1
3	Enable Unicast Drop	R/W	Enable unicast drop feature due to TX base flow control scheme.	1(QOS on) / 0 (QOS off)
2	Enable TXQ Pause	R/W	Enable unicast pause frame generation due to TX base flow control scheme.	1
1	Enable RX Drop	R/W	Enable unicast drop feature due to RX base flow control scheme.	0
0	Enable RX Pause	R/W	Enable unicast pause frame generation due to RX base flow control scheme.	0

## CPU/MII Threshold Control Register (Page 0Ah/Addr 32h-33h)

**Table 157: CPU/MII Threshold Control Register (Page 0Ah/Addr 32h-33h)**

Bit	Name	R/W	Description	Default
15:4	RSVD	RO	Reserved	0
3:2	Q_THRS_SEL	R/W	<ul style="list-style-type: none"> <li>00: Same as ten or hundred.</li> <li>01: ½ as ten or hundred.</li> <li>10: 1/4 as ten or hundred.</li> <li>11: 1/8 as ten or hundred.</li> </ul>	0
1	RSVD	RO	Reserved.	0
0	EN_MII_TH_SEL	R/W ?	Enable MII Threshold Select	0

## Pre-Queue TX Drop Control Register (Page 0Ah/Addr 34h-35h)

Table 158: Pre-Queue TX Drop Control Register (Page 0Ah/Addr 34h-35h)

Bit	Name	R/W	Description	Default
15:13	RSVD	RO	Reserved	0
12	EN_PreQ_TX_DROP	R/W	Enable Pre-Queue TX Drop	0
11:8	RSVD	RO	Reserved	0
7:4	MII_TX_DROP	R/W	IMP Port TX Drop for each queue	0
3:0	LOC_TX_DROP	R/W	Local Port TX Drop for each queue	0

## MON Flow Control Reg Bus Register (Page 0Ah/Addr 36h-37h)

Table 159: MON Flow Control Reg Bus Register (Page 0Ah/Addr 36h-37h)

Bit	Name	R/W	Description	Default
15:7	RSVD	RO	Reserved	0
6:0	MON_FLOW_CON	R/W	Set which port to debug flow control internal tdm bus.	0

**Note:** For diagnostic purposes only.

## Flow Control Status 12 Register (Page 0Ah/Addr 3Ch-3Dh)

Table 160: Flow Control Status 12 Register (Page 0Ah/Addr 3Ch-3Dh)

Bit	Name	R/W	Description	Default
15:0	RXBUF_ERR_HIS	RO	When diag_hist_sel = 01: SC – Receive buffer error for pre-port: read on clear for port 31 to port 24; When diag_hist_sel = 10: – Receive buffer error for pre-port: read on clear for port 47 to port 32; When diag_hist_sel = 11: – Receive buffer error for pre-port: read on clear for port 52 to port 48.	0

**Note:** For diagnostic purposes only.

## Misc TX Flow Control Register (Page 0Ah/Addr 4Ah-4Bh)

Table 161: Misc TX Flow Control Register (Page 0Ah/Addr 4Ah-4Bh)

Bit	Name	R/W	Description	Default	Recommended Value
15:8	RSVD	RO	Reserved	0	–

**Table 161: Misc TX Flow Control Register (Page 0Ah/Addr 4Ah-4Bh)**

Bit	Name	R/W	Description	Default	Recommended Value
7:0	RSVD_BALANCE	R/W	Reserved TXQ Threshold. <ul style="list-style-type: none"> <li>• When the number of pointers queued up in the corresponding TXQ falls below this threshold, no pause/ drop operation is applied. This is to provide HOL prevention.               <ul style="list-style-type: none"> <li>– When QOS = 1; default value = 2 2</li> <li>– When QOS = 0; default value = 6 6</li> </ul> </li> </ul>		1 –

## Queue Congestion Status 0 Register (Page 0Ah/Addr 50h-51h)

**Table 162: Queue Congestion Status 0 Register (Page 0Ah/Addr 50h-51h)**

Bit	Name	R/W	Description	Default
15:0	QUEUE_CONG_MAP	R/W	Queue Congestion Map[15:0] <b>Note:</b> For diagnostic purposes only.	0

## Queue Congestion Status 1 Register (Page 0Ah/Addr 52h-53h)

**Table 163: Queue Congestion Status 1 Register (Page 0Ah/Addr 52h-53h)**

Bit	Name	R/W	Description	Default
15:0	QUEUE_CONG_MAP	R/W	Queue Congestion Map[31:16] <b>Note:</b> For diagnostic purposes only.	0

## Queue Congestion Status 2 Register (Page 0Ah/Addr 54h-55h)

**Table 164: Queue Congestion Status 2 Register (Page 0Ah/Addr 54h-55h)**

Bit	Name	R/W	Description	Default
15:0	QUEUE_CONG_MAP	R/W	Queue Congestion Map[47:32] <b>Note:</b> For diagnostic purposes only.	0

## Queue Congestion Status 3 Register (Page 0Ah/Addr 58h-59h)

**Table 165: Queue Congestion Status 3 Register (Page 0Ah/Addr 58h-59h)**

Bit	Name	R/W	Description	Default
15:6	RSVD	RO	Reserved	0



**Table 165: Queue Congestion Status 3 Register (Page 0Ah/Addr 58h-59h)**

Bit	Name	R/W	Description	Default
5:0	QUEUE_CONG_MAP	R/W	Queue Congestion Map[53:48] <b>Note:</b> For diagnostic purposes only.	0

## Queue Congestion Status 4 Register (Page 0Ah/Addr 5Ah-5Bh)

**Table 166: Queue Congestion Status 4 Register (Page 0Ah/Addr 5Ah-5Bh)**

Bit	Name	R/W	Description	Default
15:6	RSVD	RO	Reserved	0
5:0	QUEUE_CONG_MAP	R/W	Queue Congestion Map[15:0] <b>Note:</b> For diagnostic purposes only.	0

## Queue Congestion Status 5 Register (Page 0Ah/Addr 5Ch-5Dh)

**Table 167: Queue Congestion Status 5 Register (Page 0Ah/Addr 5Ch-5Dh)**

Bit	Name	R/W	Description	Default
15:6	RSVD	RO	Reserved	0
5:0	QUEUE_CONG_MAP	R/W	Queue Congestion Map[xx:xx] <b>Note:</b> For diagnostic purposes only.	0

## Queue 0 TxDsc Control Register (Page 0Ah/Addr 64h-65h)

**Table 168: Queue 0 TxDsc Control Register (Page 0Ah: Address 64h-65h)**

Bit	Name	R/W	Description	Default
15:6	RSVD	RO	Reserved. Write default. Ignore on read.	0
5:0	Q0_quota_size	R/W	The round robin weight for priority queue 0.	01h

**Note:** Maximum Q0\_quota\_size allowable is 37h.

## Queue 1 100BT Threshold Control 1 Register (Page 0Ah/Addr 6Ah–6Bh)

**Table 169: Queue 1 100BT Threshold Control 1 Register (Page 0Ah: Address 6Ah–6Bh)**

Bit	Name	R/W	Description	Default
15:8	Q1_BT100_HYST_THRS	R/W	Q1 Unpause Threshold Regulates the transmission of the TXQ-based flow control unpause frame. Under mixed-speed mode, when Q0 reaches a pause condition, and the number of pointers queued up in the corresponding TXQ (Q1) drops below this threshold, an unpause frame is dispatched. The effective threshold is the default value multiplied by 8.	13h
7:0	Q1_BT100_PAUS_THRS	R/W	Q1 Pause Threshold Regulates the transmission of the TXQ-based flow control pause frame. Under mixed-speed mode, when the number of pointers queued up in the corresponding TXQ (Q1) exceeds this threshold, a pause frame is dispatched. The effective threshold is the default value multiplied by 8.	1Ch

**Note:** When QoS is disabled, this register is ignored.

## Queue 1 100BT Threshold Control 2 Register (Page 0Ah/Addr 6Ch–6Dh)

**Table 170: Queue 1 100BT Threshold Control 2 Register (Page 0Ah: Address 6Ch–6Dh)**

Bit	Name	R/W	Description	Default	Recommended Value
15:8	Q1_BT100_DROP_THRS	R/W	Q1 Unicast Drop Threshold Regulates incoming unicast frames. Under mixed-speed mode, when the number of pointers queued up in the corresponding TXQ (Q1) exceeds this threshold, all incoming unicast frames will be dropped. The effective threshold is the default value multiplied by 8.	9Fh	98
7:0	Q1_BT100_MCDROP_THRS	R/W	Q1 Multicast Drop Threshold Regulates incoming multicast frames. Under mixed-speed mode, when the number of pointers queued up in the corresponding TXQ (Q1) exceeds this threshold, all incoming multicast frames will be dropped. The effective threshold is the default value multiplied by 8.	9Fh	73

**Table 170: Queue 1 100BT Threshold Control 2 Register (Page 0Ah: Address 6Ch–6Dh)**

Bit	Name	R/W	Description	Recommended Value
-----	------	-----	-------------	-------------------

**Note:** When QoS is disabled, this register is ignored.

## Queue 1 TxDsc Control Register (Page 0Ah/Addr 72h–73h)

**Table 171: Queue 1 TxDsc Control Register (Page 0Ah: Address 72h–73h)**

Bit	Name	R/W	Description	Default
15:6	RSVD	RO	Reserved. Write default. Ignore on read.	0
5:0	Q1_quota_size	R/W	The round robin weight for priority queue 0.	02h

**Note:** Maximum Q1\_quota\_size allowable is 37h.

## Queue 2 100TX Threshold Control 1 Register (Page 0Ah/Addr 78h–79h)

**Table 172: Queue 2 100TX Threshold Control 1 Register (Page 0Ah: Address 78h–79h)**

Bit	Name	R/W	Description	Default
15:8	Q2_BT100_HYST_THRS	R/W	Q2 Unpause Threshold Regulates the transmission of the TXQ-based flow control unpause frame. Under mixed-speed mode, when Q0 reaches a pause condition, and the number of pointers queued up in the corresponding TXQ (Q2) drops below this threshold, an unpause frame is dispatched. The effective threshold is the default value multiplied by 8.	13h
7:0	Q2_BT100_PAUS_THRS	R/W	Q2 Pause Threshold Regulates the transmission of the TXQ-based flow control pause frame. Under mixed-speed mode, when the number of pointers queued up in the corresponding TXQ (Q2) exceeds this threshold, a pause frame is dispatched. The effective threshold is the default value multiplied by 8.	1Ch

**Note:** When QoS is disabled, this register is ignored.

## Queue 2 100TX Threshold Control 2 Register (Page 0Ah/Addr 7Ah–7Bh)

**Table 173: Queue 2 100TX Threshold Control 2 Register (Page 0Ah: Address 7Ah–7Bh)**

Bit	Name	R/W	Description	Default	Recommended Value
15:8	Q2_BT100_DROP_THRS	R/W	Q2 Unicast Drop Threshold Regulates incoming unicast frames. Under mixed- speed mode, when the number of pointers queued up in the corresponding TXQ (Q2) exceeds this threshold, all incoming unicast frames will be dropped. The effective threshold is the default value multiplied by 8.	9Fh	98
7:0	Q2_BT100_MCDROP_THRS	R/W	Q2 Multicast Drop Threshold Regulates incoming multicast frames. Under mixed- speed mode, when the number of pointers queued up in the corresponding TXQ (Q2) exceeds this threshold, all incoming multicast frames will be dropped. The effective threshold is the default value multiplied by 8.	9Fh	73

**Note:** When QoS is disabled, this register is ignored.

## Queue 2 TxDsc Control Register (Page 0Ah/Addr 80h–81h)

**Table 174: Queue 2 TxDsc Control Register (Page 0Ah: Address 80h–81h)**

Bit	Name	R/W	Description	Default
15:6	RSVD	RO	Reserved. Write default. Ignore on read.	0
5:0	Q2_quota_size	R/W	The round robin weight for priority queue 0.	04h

**Note:** Maximum Q2\_quota\_size allowable is 37h.

## Queue 3 100TX Threshold Control 1 Register (Page 0Ah/Addr 86h–87h)

**Table 175: Queue 3 100TX Threshold Control 1 Register (Page 0Ah: Address 86h–87h)**

Bit	Name	R/W	Description	Default
15:8	Q3_BT100_HYST_THRS	R/W	Q3 Unpause Threshold Regulates the transmission of the TXQ-based flow control unpause frame. Under mixed-speed mode, when Q0 reaches a pause condition, and the number of pointers queued up in the corresponding TXQ (Q3) drops below this threshold, an unpause frame is dispatched. The effective threshold is the default value multiplied by 8.	13h
7:0	Q3_BT100_PAUS_THRS	R/W	Q3 Pause Threshold Regulates the transmission of the TXQ-based flow control pause frame. Under mixed-speed mode, when the number of pointers queued up in the corresponding TXQ (Q3) exceeds this threshold, a pause frame is dispatched. The effective threshold is the default value multiplied by 8.	1Ch

## Queue 3 100TX Threshold Control 2 Register (Page 0Ah/Addr 88h–89h)

**Table 176: Queue 3 100TX Threshold Control 2 Register (Page 0Ah: Address 88h–89h)**

Bit	Name	R/W	Description	Default	Recommended Value
15:8	Q3_BT100_DROP_THRS	R/W	Q3 Unicast Drop Threshold Regulates incoming unicast frames. Under mixed-speed mode, when the number of pointers queued up in the corresponding TXQ (Q3) exceeds this threshold, all incoming unicast frames will be dropped. The effective threshold is the default value multiplied by 8.	9Fh	98
7:0	Q3_BT100_MCDROP_THRS	R/W	Q3 Multicast Drop Threshold Regulates incoming multicast frames. Under mixed-speed mode, when the number of pointers queued up in the corresponding TXQ (Q3) exceeds this threshold, all incoming multicast frames will be dropped. The effective threshold is the default value multiplied by 8.	9Fh	73

## RX Base Buffer Number Register (Page 0Ah/Addr 8Ah-8Bh)

*Table 177: RX Base Buffer Number Register (Page 0Ah/Addr 8Ah-8Bh)*

Bit	Name	R/W	Description	Default
15:8	RXBase_RESV_BUFNUM	RO	The reserved buffer number for each port when the RX base flow control is calculated. No pause/drop action will occur if the buffer number used by a port is less than this register. The effective number is this register value.	0Fh
7:0	RXBase_HYST_BUFNUM	R/W	The hyster buffer number for each port when the RX base flow control is calculated.	14h

## Queue 3 TxDsc Control Register (Page 0Ah/Addr 8Eh-8Fh)

*Table 178: Queue 3 TxDsc Control Register (Page 0Ah: Address 8Eh-8Fh)*

Bit	Name	R/W	Description	Default
15:6	RSVD	RO	Reserved Write default. Ignore on read.	0
5:0	Q3_quota_size	R/W	The round robin weight for priority queue 3.	08h

**Note:** Maximum Q3\_quota\_size allowable is 37h.

## Reserved Buffer Number Register (Page 0Ah/Addr 90h-91h)

*Table 179: Reserved Buffer Number Register (Page 0Ah/Addr 90h-91h)*

Bit	Name	R/W	Description	Default
15:12	RSVD	RO	Reserved	0
11	EN_RELOAD_ERR_PATH	R/W	Enable reload error path.	0
10	EN_LCOL_FLUSH	R/W	Enable local collision flush function.	0
9	DIS_NEW_TXDIS	R/W	Disable new tx_disable function.	0
8	EN_2SEC_FLUSH	R/W	Enable two second flush function.	0
7:0	RUNOFF	R/W	Runoff	13h

## Received Base Flow Control Register (Page 0Ah/Addr 92h-93h)

**Table 180: Received Base Flow Control Register (Page 0Ah/Addr 92h-93h)**

Bit	Name	R/W	Description	Default
15	RSVD	RO	Reserved	0
14	SW_ENFDXFLOW	R/W	<b>Note:</b> SW_ENFDXFLOW is reserved for engineer testing only.	1
13	EN_UNPAUSE_HDL	R/W	Enables pause-cap and pause-uncap handle.	1
12	EN_RX_FCON_PAUSE_REMAP	R/W	Enables RX base flow control pause threshold remap. Provides more control over commencement of flow control due to RX base scheme.	0
11:0	RX_FCON_PAUSE_THRS	R/W	Allows pause threshold to start flow control. When the available buffer reaches threshold, all the ports use more than the reserved buffer. This forces a pause. The effective number is this register.	5C0h

## DLF Threshold Drop Register (Page 0Ah/Addr 94h-95h)

**Table 181: DLF Threshold Drop Register (Page 0Ah: Address 94h-95h)**

Bit	Name	R/W	Description	Default	Recommended Value
15:8	TOTAL_INDV_DLFTH_DROP	R/W	Total individual DLF drop threshold. Regulates total incoming DLF frames. When EN_DLF_BC_DROP_THRS of <a href="#">“Global Option Control Register (Page 0Ah/Addr 30h-31h)”</a> on page 237 is asserted, the total incoming DLF frames exceed this threshold are dropped. The effective threshold is the default value multiplied by 8.	B2h	7E
7:0	INDV_DLFTH_DROP	R/W	Individual DLF drop threshold. Regulates individual port incoming DLF frames. When EN_DLF_BC_DROP_THRS of <a href="#">“Global Option Control Register (Page 0Ah/Addr 30h-31h)”</a> on page 237 is asserted, the incoming DLF frames at individual port exceed this threshold are dropped. The effective threshold is the default value multiplied by 8.	9Fh	–

## Broadcast Threshold Drop Register (Page 0Ah/Addr 96h–97h)

Table 182: Broadcast Threshold Drop Register (Page 0Ah: Address 96h–97h)

Bit	Name	R/W	Description	Default	Recommended Value
15:8	TOTAL_INDV_BCSTTH_DROP	R/W	Total individual broadcast drop threshold. Regulates total incoming Broadcast frames. When EN_DLF_BC_DROP_THRS of “Global Option Control Register (Page 0Ah/Addr 30h–31h)” on page 237 is asserted, the total incoming Broadcast frames exceed this threshold are dropped. The effective threshold is the default value multiplied by 8.	B2h	7E
7:0	INDV_BCSTTH_DROP	R/W	Individual broadcast drop threshold. Regulates individual port incoming Broadcast frames. When EN_DLF_BC_DROP_THRS of “Global Option Control Register (Page 0Ah/Addr 30h–31h)” on page 237 is asserted, the incoming Broadcast frames at individual port exceed this threshold are dropped. The effective threshold is the default value multiplied by 8.	9Fh	–

## LAN to IMP Unicast Control Register (Page 0Ah/Addr A0h–A1h)

Table 183: LAN to IMP MC Control 1 Register (Page 0Ah: Address A0h–A1h)

Bit	Name	R/W	Description	Default
15	IMP_CONGST_REMAP_EN	R/W	Remap IMP Port Congestion Status <ul style="list-style-type: none"> <li>1 = Remap from PAUSE to DROP</li> </ul>	0
14:1	RSVD	RO	Reserved	0
0	REMAP_PAUSE_DROP_EN	R/W	<ul style="list-style-type: none"> <li>1 = Remap PAUSE to DROP</li> <li>0 = Remap PAUSE to Hysteresis</li> </ul> <b>Note:</b> Reserved for internal test only.	1



## LAN to IMP Multicast Control 1 Register (Page 0Ah/Addr A2h–A3h)

**Table 184: LAN to IMP MC Control 1 Register (Page 0Ah: Address A2h–A3h)**

Bit	Name	R/W	Description	Default
15:1	RSVD	–	Reserved	0
0	MC_IMP_DROP_EN	R/W	When this bit is set, activates the MC_IMP_DROP_THRSHLD in “LAN to IMP Multicast Control 2 Register (Page 0Ah/Addr A4h–A5h)” on page 249.	0

## LAN to IMP Multicast Control 2 Register (Page 0Ah/Addr A4h–A5h)

**Table 185: LAN to IMP MC Control 2 Register (Page 0Ah: Address A4h–A5h)**

Bit	Name	R/W	Description	Default
15:8	RSVD	RO	Reserved	0
7:0	MC_IMP_DROP_THRSHLD	R/W	Total use threshold for MC traffic from LAN to IMP.	6Ch

## IMP to LAN Control 1 Register (Page 0Ah/Addr B0h–B1h)

**Table 186: IMP to LAN Control 1 Register (Page 0Ah: Address B0h–B1h)**

Bit	Name	R/W	Description	Default
15:1	RSVD	RO	Reserved	0
0	High_Rate_IMP_PAUSE_EN	R/W	<ul style="list-style-type: none"> <li>1 = Remap LAN-ports congestion status observed by IMP port from Drop/Pause to Pause/Hysteresis</li> </ul>	0

## IMP to LAN Control 2 Register (Page 0Ah/Addr B2h–B3h)

**Table 187: LAN to IMP MC Control 2 Register (Page 0Ah: Address B2h–B3h)**

Bit	Name	R/W	Description	Default
15:8	DROP_IMP_THRSHLD	RO	If the total buffer use exceeds this threshold, the drop congestion status observed by the IMP port does not remap to pause.	BCh
7:0	PAUSE_IMP_THRSHLD	R/W	If the total buffer use exceeds this threshold, the pause congestion status observed by the IMP port does not remap to hysteresis.	AAh

## Queue 1 Total Threshold Control 1 Register (Page 0Ah/Addr C0h–C1h)

*Table 188: Queue 1 Total Threshold Control 1 Register (Page 0Ah: Address C0h–C1h)*

Bit	Name	R/W	Description	Default	Recommended Value
15:8	HYST_THRSHLD_Q1	RO	–	61h	46
7:0	PAUSE_THRSHLD_Q1	R/W	Total pause threshold for Q1	8Ch	80

## Queue 1 Total Threshold Control 2 Register (Page 0Ah/Addr C2h–C3h)

*Table 189: Queue 1 Total Threshold Control 2 Register (Page 0Ah: Address C2h–C3h)*

Bit	Name	R/W	Description	Default	Recommended Value
15:8	Total_Drop_THRSHLD_Q1	R/W	Total drop threshold for Q1	B4h	9D
7:0	RSVD	RO	Reserved	0	7E

## Queue 2 Total Threshold Control 1 Register (Page 0Ah/Addr C4h–C5h)

*Table 190: Queue 2 Total Threshold Control 1 Register (Page 0Ah: Address C4h–C5h)*

Bit	Name	R/W	Description	Default	Recommended Value
15:8	HYST_THRSHLD_Q2	RO	–	61h	48
7:0	PAUSE_THRSHLD_Q2	R/W	Total pause threshold for Q2	93h	82

## Queue 2 Total Threshold Control 2 Register (Page 0Ah/Addr C6h–C7h)

*Table 191: Queue 2 Total Threshold Control 2 Register (Page 0Ah: Address C6h–C7h)*

Bit	Name	R/W	Description	Default	Recommended Value
15:8	Total_Drop_THRSHLD_Q2	R/W	Total drop threshold for Q2	B6h	9F
7:0	RSVD	RO	Reserved	0	7E

## Queue 3 Total Threshold Control 1 Register (Page 0Ah/Addr C8h–C9h)

*Table 192: Queue 3 Total Threshold Control 1 Register (Page 0Ah: Address C8h–C9h)*

Bit	Name	R/W	Description	Default	Recommended Value
15:8	HYST_THRSHLD_Q3	RO	–	61h	4A

**Table 192: Queue 3 Total Threshold Control 1 Register (Page 0Ah: Address C8h–C9h)**

Bit	Name	R/W	Description	Default	Recommended Value
7:0	PAUSE_THRSHLD_Q3	R/W	Total pause threshold for Q3	9Bh	84

### Queue 3 Total Threshold Control 2 Register (Page 0Ah/Addr CAh–CBh)

**Table 193: Queue 3 Total Threshold Control 2 Register (Page 0Ah: Address CAh–CBh)**

Bit	Name	R/W	Description	Default	Recommended Value
15:8	Total_Drop_THRSHLD_Q3	R/W	Total drop threshold for Q3	B8h	A1
7:0	RSVD	RO	Reserved	0	7E

### Queue 1 Total BC/DLF Drop Threshold Control Register (Page 0Ah/Addr D0h-D1h)

**Table 194: Queue 1 Total BC/DLF Drop Threshold Control Register (Page 0Ah/Addr D0h-D1h)**

Bit	Name	R/W	Description	Default	Recommended Value
15:8	Total_DLF_DROP_THRESH_Q1	R/W	Total DLF drop threshold for Q1	B4h	7E
7:0	TOTAL_BC_DROP_THRESH_Q1	R/W	Total BC drop threshold for Q1.	B4h	7E

### Queue 2 Total BC/DLF Drop Threshold Control Register (Page 0Ah/Addr D2h-D3h)

**Table 195: Queue 2 Total BC/DLF Drop Threshold Control Register (Page 0Ah/Addr D2h-D3h)**

Bit	Name	R/W	Description	Default	Recommended Value
15:8	Total_DLF_DROP_THRESH_Q2	R/W	Total DLF drop threshold for Q2	B6h	7E
7:0	TOTAL_BC_DROP_THRESH_Q2	R/W	Total BC drop threshold for Q2	B6h	7E

### Queue 3 Total BC/DLF Drop Threshold Control Register (Page 0Ah/Addr D4h-D5h)

**Table 196: Queue 3 Total BC/DLF Drop Threshold Control Register (Page 0Ah/Addr D4h-D5h)**

Bit	Name	R/W	Description	Default	Recommended Value
15:8	Total_DLF_DROP_THRESH_Q3	R/W	Total DLF drop threshold for Q3	B8h	7E

**Table 196: Queue 3 Total BC/DLF Drop Threshold Control Register (Page 0Ah/Addr D4h-D5h)**

<b>Bit</b>	<b>Name</b>	<b>R/W</b>	<b>Description</b>	<b>Default</b>	<b>Recommended Value</b>
7:0	TOTAL_BC_DROP_THRESH_Q3	R/W	Total BC drop threshold for Q3	B8h	7E

Broadcom Confidential

## Page 0Dh: TBI Registers

**Table 197: TBI Registers (Page 0Dh)**

Address	Bits	Description
00h–01h		“TBI Control Register (Page 0Dh/Addr 00h–01h)” on page 253
02h		“PRBS Control Register (Page 0Dh/Addr 02h)” on page 254
03h–06h		“PRBS Status Register (Page 0Dh/Addr 03h–06h)” on page 255
07h		“MR Status Register (Page 0Dh/Addr 07h)” on page 256
08h		“SGMII Clear Control Register (Page 0Dh/Addr 08h)” on page 256
09h–4Fh	Reserved	
50h–51h		Port 25 “Gigabit Port SGMII Control Register (Page 0Dh/Addr 50h–53h)” on page 257
52h–53h		Port 26 “Gigabit Port SGMII Control Register (Page 0Dh/Addr 50h–53h)” on page 257
54h–55h		Port 25 “Gigabit Port SGMII Status Register (Page 0Dh/Addr 54h–57h)” on page 258
56h–57h		Port 26 “Gigabit Port SGMII Status Register (Page 0Dh/Addr 54h–57h)” on page 258
58h–59h		Port 25 “Gigabit Port Link Partner Link Status Register (Page 0Dh/Addr 58h–5Bh)” on page 258
5Ah–5Bh		Port 26 “Gigabit Port Link Partner Link Status Register (Page 0Dh/Addr 58h–5Bh)” on page 258
5Ch–5Dh		Port 25 “Gigabit Port CRC16 Register (Page 0Dh/Addr 5Ch–5Fh)” on page 258
5Eh–5Fh		Port 26 “Gigabit Port CRC16 Register (Page 0Dh/Addr 5Ch–5Fh)” on page 258
60h–EFh	Reserved	
F0h–F7h		SPI Data I/O[0:7]
F8h–FDh	Reserved	
FFh	8	Page register

## TBI Control Register (Page 0Dh/Addr 00h–01h)

**Table 198: TBI Control Register (Page 0Dh: Address 00h–01h)**

Bit	Name	R/W	Description	Default
15:14	bypass_10b	R/W	Bypass TBI edcode/encode function. <ul style="list-style-type: none"> <li>• Bit 14 = GigaPort G0</li> <li>• Bit 15 = GigaPort G1.</li> </ul>	00

**Table 198: TBI Control Register (Page 0Dh: Address 00h–01h)**

Bit	Name	R/W	Description	Default
13:12	sgmii_restart_an[1:0]	R/W	The signal is used to restart SGMII autoneg. Active high and self clear. <ul style="list-style-type: none"> <li>Bit 12 = GigaPort G0</li> <li>Bit 13 = GigaPort G1.</li> </ul>	00
11:10	Reserved	RO		00
9:8	fiber_mode[1:0]	R/W	Enable fiber mode. Active high. Enabling fiber mode affects AutoNeg function. When 1, the autoneg complies with IEEE claus 37 defined AutoNeg, otherwise, it is SGMII Autoneg. <ul style="list-style-type: none"> <li>Bit 8 = GigaPort G0.</li> <li>Bit 9 = GigaPort G1.</li> </ul>	3h
7:6	mr_hd[1:0]	R/W	AN Half duplex capability. If this bit is set to 1, SerDes AutoNeg advertises half duplex ability. The mr_hd and mr_fd can be set to 1 at the same time to indicate able to support half/full duplex. <ul style="list-style-type: none"> <li>Bit 6 = GigaPort G0.</li> <li>Bit 7 = GigaPort G1.</li> </ul>	00
5:4	mr_fd[1:0]	R/W	AN Full duplex capability. If this bit is set to 1, SerDes AutoNeg advertises full duplex ability. The mr_hd and mr_fd can be set to 1 at the same time to indicate able to support half/full duplex. <ul style="list-style-type: none"> <li>Bit 4 = GigaPort G0.</li> <li>Bit 5 = GigaPort G1.</li> </ul>	3h
3:2	Reserved	RO		00
1:0	mr_main_reset	R/W	Software reset, height enable (extended to 1.7 $\mu$ s long internally)	00

## PRBS Control Register (Page 0Dh/Addr 02h)

**Table 199: PRBS Control Register (Page 0Dh: Address 02h)**

Bit	Name	R/W	Description	Default
7:4	prbs_order [3:0]	R/W	<ul style="list-style-type: none"> <li>00 = <math>x(n) = 1 + x(6) + x(7)</math></li> <li>01 = <math>x(n) = 1 + x(14) + x(15)</math></li> <li>10 = <math>x(n) = 1 + x(14) + x(15)</math></li> <li>11 = <math>x(n) = 1 + x(28) + x(31)</math></li> <li>Bit 3:2 for GigaPort G1</li> <li>Bit 1:0 for GigaPort G0</li> </ul>	00

**Table 199: PRBS Control Register (Page 0Dh: Address 02h)**

<b>Bit</b>	<b>Name</b>	<b>R/W</b>	<b>Description</b>	<b>Default</b>
3:2	prbs_en [1:0]	R/W	Enable PRBS generator, when this bit is enabled, 00 fiber_mode and en10b need to be asserted together because it generates the nonethernet packet. <ul style="list-style-type: none"> <li>• Bit 0 = GigaPort G0.</li> <li>• Bit 1 = GigaPort G1.</li> </ul>	
1:0	prbs_err_clr[1:0]	R/W	Clear PRBS error counter value. <ul style="list-style-type: none"> <li>• Bit 0 = GigaPort G0.</li> <li>• Bit 1 = GigaPort G1.</li> </ul> This bit is a write and clear bit.	00

## PRBS Status Register (Page 0Dh/Addr 03h–06h)

**Table 200: PRBS Status Register (Page 0Dh: Address 03h–06h)**

<b>Bit</b>	<b>Name</b>	<b>R/W</b>	<b>Description</b>	<b>Default</b>
31:18	prbs_errors_p26 [13:0]	RO	Port 26 PRBS error counter	0000h
17:4	prbs_errors_p25 [13:0]	RO	Port 25 PRBS error counter	000h
3:2	prbs_lock [1:0]	RO	PRBS monitor is locked. <ul style="list-style-type: none"> <li>• Bit 0 = GigaPort G0.</li> <li>• Bit 1 = GigaPort G1.</li> </ul>	00
1:0	prbs_stky[1:0]	RO	PRBS Lost lock sticky bit. <ul style="list-style-type: none"> <li>• Bit 0 = GigaPort G0.</li> <li>• Bit 1 = GigaPort G1.</li> </ul>	00

## MR Status Register (Page 0Dh/Addr 07h)

Table 201: MR Status Register (Page 0Dh: Address 07h)

Bit	Name	R/W	Description	Default
7:6	mr_page_rx[1:0]	RO	Reg6.1 to indicate base page received. <ul style="list-style-type: none"> <li>Bit 0 = GigaPort G0.</li> <li>Bit 1 = GigaPort G1.</li> </ul>	00
5:4	mr_remote_fault[1:0]	RO	Reg1.4 to indicated remote fault detected. <ul style="list-style-type: none"> <li>Bit 0 = GigaPort G0.</li> <li>Bit 1 = GigaPort G1.</li> </ul>	00
3:2	Reserved	RO		00
1:0	pr_error[1:0]	RO	Priority resolution error used for local device remote fault <ul style="list-style-type: none"> <li>Bit 0 = GigaPort G0.</li> <li>Bit 1 = GigaPort G1.</li> </ul>	00

## SGMII Clear Control Register (Page 0Dh/Addr 08h)

Table 202: SGMII Clear Control Register (Page 0Dh: Address 08h)

Bit	Name	R/W	Description	Default
7:4	Reserved	RO		0
3:2	sgmii_status_clear	R/W	This signals is the one to clear SGMII status register once it is read. <ul style="list-style-type: none"> <li>Bit 0 = GigaPort G0.</li> <li>Bit 1 = GigaPort G1.</li> </ul> Active low signal.	11
1:0	sgmii_crc16	RO	This signals is the one to clear CRC16 register once it is read. <ul style="list-style-type: none"> <li>Bit 0 = GigaPort G0.</li> <li>Bit 1 = GigaPort G1.</li> </ul> Active low signal.	11



## Gigabit Port SGMII Control Register (Page 0Dh/Addr 50h–53h)

**Table 203: Gigabit Port SGMII Control Register (Page 0Dh: Address 50h–53h)**

Bit	Name	R/W	Description	Default
15	force_data_mode	R/W	When 1, synchronization and data valid won't be detected. By setting this bit to 1 and en10b=1, cdet_en=1, user can use GMII to directly send and receive raw TBI data to and from analog SerDes.	0
14:13	Remote Fault[1:0]	R/W	To Set remote fault bits in AutoNeg link code word. This only works when an_sel = 1.	00
12:11	Pause[1:0]	R/W	To Set Pause bits in AutoNeg link code word. This only works when an_sel = 1.	00
10	an_sel	R/W	When 0, select SGMII auto-neg. Otherwise, select IEEE clause 37 complied auto-neg.	0
9	tx_short_latency_en	R/W	<ul style="list-style-type: none"> <li>0 = assert 1-nibble (max) early preamble in 100/10 mode</li> <li>1 = No early preamble is asserted</li> </ul>	0
8	err_timer_en	R/W	Enable error timer in auto-neg for testability.	0
7	rev_phase	R/W	When 1, latch 10 bit data from analog SerDes by falling edge of clock, otherwise latch data at rising edge of clock.	0
6	Reserved	R/W	–	0
5	short_latency_en	R/W	Enable short latency function that makes RX side start sending preamble when CRS is detected. When this bit is disabled, it only affects speed 1000. This bit is used when user plans to send nonethernet packet.	0
4	cdet_en	R/W	When 1, Disable comma detector.	0
3	an_tst_mode	R/W	Reduce timer for AutoNeg testing.	0
2	sg_an_disable	R/W	When 1, Disable AutoNeg directly to Data Mode.	0
1	remote_lpbk	R/W	Remote loop-back for testability.	0
0	tbi_lpbk	R/W	TBI loop-back for testability.	0

## Gigabit Port SGMII Status Register (Page 0Dh/Addr 54h–57h)

**Table 204: Gigabit Port SGMII Status Register (Page 0Dh: Address 54h–57h)**

Bit	Name	R/W	Description	Default
15	pr_rx_ps_en	RO	The result of priority resolution to enable PAUSE 0 receive.	0
14	pr_tx_ps_en	RO	The result of priority resolution to enable PAUSE 0 transmit.	0
13	pr_duplex	RO	Priority resolution for duplex indication	0
12	sgmii_enable	RO	SGMII enable indication	0
11:8	r_an_sta_upper	RO	To indicate the highest AN FSM state variable.	0
7:4	r_an_sta_lower	RO	To indicate the lowest AN FSM state variable	0
3	com_det	RO	Indicate comma detected.	0
2	sg_mac_ack	RO	Indicate the MAC acknowledge bit status	0
1	sg_an_complete	RO	To indicate AN complete.	0
0	sg_an_error	RO	To indicate AN error	0

## Gigabit Port Link Partner Link Status Register (Page 0Dh/Addr 58h–5Bh)

**Table 205: Gigabit Port Link Partner Link Status Register (Page 0Dh: Address 58h–5Bh)**

Bit	Name	R/W	Description	Default
15:0	mr_lp_adv_ability	RO	Link partner's link code word. In SGMII mode, if mac_mode = : <ul style="list-style-type: none"> <li>• 0, refer to tx_config_reg[15:0] from MAC to PHY in SGMII Specification</li> <li>• 1, refer to tx_config_reg[15:0] from PHY to MAC in SGMII Specification</li> </ul> In fiber mode, the data is from the link partner.	0000h

## Gigabit Port CRC16 Register (Page 0Dh/Addr 5Ch–5Fh)

**Table 206: Gigabit Port CRC16 Register (Page 0Dh: Address 5Ch–5Fh)**

Bit	Name	R/W	Description	Default
15:0	sgmii_crc16_p	RO	Send 16 bit CRC value. It is cleared by crc16_clear_n or during the preamble in the next packet. Calculation is valid for GMII/MII packets with preamble and SFD	0000h

## Page 10h: PHY Info Registers

**Table 207: PHY Info Registers (Page 10h)**

Address	Bits	Register Name
00h–03h	Reserved	
04h–05h	16	“PHY ID High Register (Page 10h/Addr 04h)” on page 259
06h–07h	16	“PHY ID Low Register (Page 10h/Addr 06h)” on page 259
08h–EFh	Reserved	
F0h–F7h	–	SPI Data I/O[0:7]
F8h–FDh	Reserved	
FEh	–	SPI Status
FFh	8	Page Register

### PHY ID High Register (Page 10h/Addr 04h)

**Table 208: PHY ID High Register (Page 10h: Address 04h)**

Bit	Name	R/W	Description	Default
15:0	MII_ADDR	RO	PHYID HIGH	0143h

### PHY ID Low Register (Page 10h/Addr 06h)

**Table 209: PHY ID Low Register (Page 10h: Address 06h)**

Bit	Name	R/W	Description	Default
15:0	MII_ADDR	RO	PHY ID LOW	BF1Nh

Where N[3:2], the upper 2 bits of the nibble denote the revision and the lower 2 bits, N[1:0] denote the stepping.

**Table 210: Chip Revision**

N		Revision	Stepping
00	00	A	0
	01		1
	10		2
	11		3
01	00	B	0
	01		1
	10		2
	11		3

**Table 210: Chip Revision**

	N	Revision	Stepping
10	00	C	0
	01		1
	10		2
	11		3
11	00	D	0
	01		1
	10		2
	11		3

## Page 20h: CFP Registers

**Table 211: CFP Registers (Page 20h)**

Address	Bits	Register Name
00h–03h	32	<a href="#">“CFP Access Register (Page 20h/Addr 00h–03h)” on page 262</a>
04h–0Fh	Reserved	
10h–17h	64	<a href="#">“CFP TCAM Data 0 Register (Page 20h/Addr 10h–17h)” on page 262</a>
18h–1Fh	64	<a href="#">“CFP TCAM Data 1 Register (Page 20h/Addr 18h–1Fh)” on page 263</a>
20h–27h	64	<a href="#">“CFP TCAM Data 2 Register (Page 20h/Addr 20h–27h)” on page 263</a>
28h–2Fh	64	<a href="#">“CFP TCAM Data 3 Register (Page 20h/Addr 28h–2Fh)” on page 263</a>
30h–37h	64	<a href="#">“CFP TCAM Data 4 Register (Page 20h/Addr 30h–37h)” on page 263</a>
38h–3Fh	64	<a href="#">“CFP TCAM Data 5 Register (Page 20h/Addr 38h–3Fh)” on page 264</a>
40h–47h	64	<a href="#">“CFP TCAM Mask 0 Register (Page 20h/Addr 40h–47h)” on page 264</a>
48h–4Fh	64	<a href="#">“CFP TCAM Mask 1 Register (Page 20h/Addr 48h–4Fh)” on page 264</a>
50h–57h	64	<a href="#">“CFP TCAM Mask 2 Register (Page 20h/Addr 50h–57h)” on page 264</a>
58h–5Fh	64	<a href="#">“CFP TCAM Mask 3 Register (Page 20h/Addr 58h–5Fh)” on page 265</a>
60h–67h	64	<a href="#">“CFP TCAM Mask 4 Register (Page 20h/Addr 60h–67h)” on page 265</a>
68h–6Fh	64	<a href="#">“CFP TCAM Mask 5 Register (Page 20h/Addr 68h–6Fh)” on page 265</a>
70h–75h	48	<a href="#">“CFP Action Policy Data Register (Page 20h/Addr 70h–75h)” on page 265</a>
74h–7Fh	Reserved	
80h–83h	32	<a href="#">“CFP Rate Meter Configuration Register (Page 20h/Addr 80h–83h)” on page 270</a>
88h–8Fh	Reserved	
90h–93h	32	<a href="#">“CFP Rate Inband Statistic Register (Page 20h/Addr 90h–93h)” on page 270</a>
94h–97h	32	<a href="#">“CFP Rate Outband Statistic Register (Page 20h/Addr 94h–97h)” on page 270</a>

**Table 211: CFP Registers (Page 20h) (Cont.)**

<b>Address</b>	<b>Bits</b>	<b>Register Name</b>
F0h–F7h	–	SPI Data I/O[0:7]
F8h–FDh	Reserved	
FEh	–	SPI Status
FFh	8	Page Register

Broadcom Confidential

## CFP Access Register (Page 20h/Addr 00h–03h)

**Table 212: CFP Access Register (Page 20h: Address 00h–03h)**

Bit	Name	R/W	Description	Default
31	RATE_MTR_EN	R/W	Rate Meter Enable This bit enables the hardware for Rate Meter function. Software should set this bit after the Rate Meter Memory has been initialized.	0
30:19	RSVD	R/W	Reserved	0
18:9	ACCESS_ADDR	R/W	Indicates the address offset of the RAM blocks for the operation. For a Read and Write operation, this is the target address for the TCAM and RAM blocks.	0
8:4	MEM_SEL	R/W	RAM Selection. A single bit field selects the target of the operation. <ul style="list-style-type: none"> <li>• 10000 = Out-band Statistic RAM</li> <li>• 01000 = In-band Statistic RAM</li> <li>• 00100 = Rate Meter RAM</li> <li>• 00010 = Action/Policy RAM</li> <li>• 00001 = TCAM</li> <li>• 00000 = No Operation</li> <li>• Others = Reserved</li> </ul>	0
3:0	OP_CODE	R/W	Operation Select <ul style="list-style-type: none"> <li>• 0011: Memory Fill operation. Software runs the operation to fill data to the memory assigned by MEM_SEL.</li> <li>• 0010: Write operation (for TCAM and RAM)</li> <li>• 0001: Read operation (for TCAM and RAM)</li> <li>• 0000: No operation</li> <li>• Others: Reserved</li> </ul>	0

## CFP TCAM Data 0 Register (Page 20h/Addr 10h–17h)

**Table 213: CFP TCAM Data 0 Register (Page 20h: Address 10h–17h)**

Bit	Name	R/W	Description	Default
63:0	TCAM_DATA0[63:0]	R/W	TCAM Data for different Opcode For Opcode = 4'b0001 <ul style="list-style-type: none"> <li>• The output of TCAM data [63:0]</li> </ul> For Opcode = 4'b0010 <ul style="list-style-type: none"> <li>• The input of TCAM data [63:0]</li> </ul>	0

## CFP TCAM Data 1 Register (Page 20h/Addr 18h–1Fh)

*Table 214: CFP TCAM Data 1 Register (Page 20h: Address 18h–1Fh)*

Bit	Name	R/W	Description	Default
63:0	TCAM_DATA1[127:64]	R/W	TCAM Data for different Opcode For Opcode = 4'b0001 <ul style="list-style-type: none"> <li>The output of TCAM data [127:64]</li> </ul> For Opcode = 4'b0010 <ul style="list-style-type: none"> <li>The input of TCAM data [127:64]</li> </ul>	0

## CFP TCAM Data 2 Register (Page 20h/Addr 20h–27h)

*Table 215: CFP TCAM Data 2 Register (Page 20h: Address 20h–27h)*

Bit	Name	R/W	Description	Default
63:0	TCAM_DATA2[191:128]	R/W	TCAM Data for different Opcode For Opcode = 4'b0001 <ul style="list-style-type: none"> <li>The output of TCAM data [191:128]</li> </ul> For Opcode = 4'b0010 <ul style="list-style-type: none"> <li>The input of TCAM data [191:128]</li> </ul>	0

## CFP TCAM Data 3 Register (Page 20h/Addr 28h–2Fh)

*Table 216: CFP TCAM Data 3 Register (Page 20h: Address 28h–2Fh)*

Bit	Name	R/W	Description	Default
63:0	TCAM_DATA3[255:192]	R/W	TCAM Data for different Opcode For Opcode = 4'b0001 <ul style="list-style-type: none"> <li>The output of TCAM data [255:192]</li> </ul> For Opcode = 4'b0010 <ul style="list-style-type: none"> <li>The input of TCAM data [255:192]</li> </ul>	0

## CFP TCAM Data 4 Register (Page 20h/Addr 30h–37h)

*Table 217: CFP TCAM Data 4 Register (Page 20h: Address 30h–37h)*

Bit	Name	R/W	Description	Default
63:0	TCAM_DATA3[319:256]	R/W	TCAM Data for different Opcode For Opcode = 4'b0001 <ul style="list-style-type: none"> <li>The output of TCAM data [319:256]</li> </ul> For Opcode = 4'b0010 <ul style="list-style-type: none"> <li>The input of TCAM data [319:256]</li> </ul>	0

## CFP TCAM Data 5 Register (Page 20h/Addr 38h–3Fh)

*Table 218: CFP TCAM Data 5 Register (Page 20h: Address 38h–3Fh)*

Bit	Name	R/W	Description	Default
63:0	TCAM_DATA3[383:320]	R/W	TCAM Data for different Opcode For Opcode = 4'b0001 <ul style="list-style-type: none"> <li>The output of TCAM data [383:320]</li> </ul> For Opcode = 4'b0010 <ul style="list-style-type: none"> <li>The input of TCAM data [383:320]</li> </ul>	0

## CFP TCAM Mask 0 Register (Page 20h/Addr 40h–47h)

*Table 219: CFP TCAM Mask 0 Register (Page 20h: Address 40h–47h)*

Bit	Name	R/W	Description	Default
63:0	TCAM_MASK0[63:0]	R/W	TCAM Mask for different Opcode For Opcode = 4'b0001 <ul style="list-style-type: none"> <li>The output of TCAM mask [63:0]</li> </ul> For Opcode = 4'b0010 <ul style="list-style-type: none"> <li>The input of TCAM mask [63:0]</li> </ul>	0

## CFP TCAM Mask 1 Register (Page 20h/Addr 48h–4Fh)

*Table 220: CFP TCAM Mask 1 Register (Page 20h: Address 48h–4Fh)*

Bit	Name	R/W	Description	Default
63:0	TCAM_MASK1[127:64]	R/W	TCAM Mask for different Opcode For Opcode = 4'b0001 <ul style="list-style-type: none"> <li>The output of TCAM mask [127:64]</li> </ul> For Opcode = 4'b0010 <ul style="list-style-type: none"> <li>The input of TCAM mask [127:64]</li> </ul>	0

## CFP TCAM Mask 2 Register (Page 20h/Addr 50h–57h)

*Table 221: CFP TCAM Mask 2 Register (Page 20h: Address 50h–57h)*

Bit	Name	R/W	Description	Default
63:0	TCAM_MASK2[191:128]	R/W	TCAM Mask for different Opcode For Opcode = 4'b0001 <ul style="list-style-type: none"> <li>The output of TCAM mask [191:128]</li> </ul> For Opcode = 4'b0010 <ul style="list-style-type: none"> <li>The input of TCAM mask [191:128]</li> </ul>	0



## CFP TCAM Mask 3 Register (Page 20h/Addr 58h–5Fh)

*Table 222: CFP TCAM Mask 3 Register (Page 20h: Address 58h–5Fh)*

Bit	Name	R/W	Description	Default
63:0	TCAM_MASK3[255:192]	R/W	TCAM Mask for different Opcode For Opcode = 4'b0001 <ul style="list-style-type: none"> <li>The output of TCAM mask [255:192]</li> </ul> For Opcode = 4'b0010 <ul style="list-style-type: none"> <li>The input of TCAM mask [255:192]</li> </ul>	0

## CFP TCAM Mask 4 Register (Page 20h/Addr 60h–67h)

*Table 223: CFP TCAM Mask 4 Register (Page 20h: Address 60h–67h)*

Bit	Name	R/W	Description	Default
63:0	TCAM_MASK4[319:256]	R/W	TCAM Mask for different Opcode For Opcode = 4'b0001 <ul style="list-style-type: none"> <li>The output of TCAM mask [319:256]</li> </ul> For Opcode = 4'b0010 <ul style="list-style-type: none"> <li>The input of TCAM mask [319:256]</li> </ul>	0

## CFP TCAM Mask 5 Register (Page 20h/Addr 68h–6Fh)

*Table 224: CFP TCAM Mask 5 Register (Page 20h: Address 68h–6Fh)*

Bit	Name	R/W	Description	Default
63:0	TCAM_MASK5[371:320]	R/W	TCAM Mask for different Opcode For Opcode = 4'b0001 <ul style="list-style-type: none"> <li>The output of TCAM mask [371:320]</li> </ul> For Opcode = 4'b0010 <ul style="list-style-type: none"> <li>The input of TCAM mask [371:320]</li> </ul>	0

## CFP Action Policy Data Register (Page 20h/Addr 70h–75h)

*Table 225: CFP Action Policy Data Register (Page 20h: Address 70h–75h)*

Bit	Name	R/W	Description	Default
47:46	RSVD	RO	Reserved. Write default. Ignore on read.	0

**Table 225: CFP Action Policy Data Register (Page 20h: Address 70h–75h) (Cont.)**

<b>Bit</b>	<b>Name</b>	<b>R/W</b>	<b>Description</b>	<b>Default</b>
45	CHNG_DSCP_OB	R/W	Change DSCP for Out-Band: <ul style="list-style-type: none"> <li>• 1 = Replace DSCP field of the corresponding packet with New_DSCP_OB</li> <li>• 0 = Ignore New_DSCP_OB content for this policy</li> </ul>	0
44:39	NEW_DSCP_OB	R/W	New DSCP value for Out-Band <ul style="list-style-type: none"> <li>• The value will replace the original DSCP value if CHNG_DSCP_OB is set</li> </ul>	0
38:37	CHNG_FWD_OB[1:0]	R/W	Change Forward Map for Out-Band <ul style="list-style-type: none"> <li>• 00: No change. Forward based on ARL forward map.</li> <li>• 01: Use NEW_FWD_OB[5:0] as final forward map</li> <li>• 10: ARL forward map is ORed with NEW_FWD_OB[5:0] to get the final forward map</li> <li>• 11: Explicit actions (such as switching drop, copy CPU, mirror) are defined by NEW_FWD_OB[5:0]</li> </ul>	0

**Table 225: CFP Action Policy Data Register (Page 20h: Address 70h–75h) (Cont.)**

<b>Bit</b>	<b>Name</b>	<b>R/W</b>	<b>Description</b>	<b>Default</b>
36:31	NEW_FWD_OB[5:0]	R/W	<p>New Destination Port Number for Out-Band.</p> <ul style="list-style-type: none"> <li>• When bits[38:37] = 01 or 10, NEW_FWD_OB[5:0] is defined as: <ul style="list-style-type: none"> <li>– 0~23 = Reserved</li> <li>– 24 = Port 0</li> <li>– ...</li> <li>– 47 = Port 23</li> <li>–</li> <li>– 48 = IMP</li> <li>– 49 = Giga Port G0</li> <li>– 50 = Giga Port G1</li> <li>– 51 ~ 62 = Reserved</li> <li>– 63 = Flood to all linked-up ports.</li> </ul> </li> <li>• When bits[38:37] = 11, NEW_FWD_OB[5:0] defines the new actions: <ul style="list-style-type: none"> <li>– 0~55 = Reserved</li> <li>– 56 = Forward packet based on ARL forward map</li> <li>– 57 = Forward packet based on ARL and copy to Mirror Capture port</li> <li>– 58 = Forward packet based on ARL and copy to IMP port</li> <li>– 59 = Forward packet based on ARL and to both IMP and Mirror Capture ports</li> <li>– 60 = Drop the packet</li> <li>– 61 = Forward packet to Mirror Capture port only</li> <li>– 62 = Forward packet to IMP port only</li> <li>– 63 = Forward packet to both IMP and Mirror Capture ports.</li> </ul> </li> </ul>	0
30:29	CHNG_FLOW		<p>change flow (VID) for In/Out-Band (modify packet)</p> <ul style="list-style-type: none"> <li>• 11 = use NEW_FLOW_INDX to get VID value on Egress side to swap CVID/SPVID at UNI/NNI port.</li> <li>• 10 = use NEW_FLOW_INDX to get VID value on Egress side to swap SPVID at NNI port</li> <li>• 01 = use NEW_FLOW_INDX to get VID value on Egress side to swap CVID at UNI port</li> <li>• 00 = do not care NEW_FLOW_INDX content for this policy</li> </ul>	0
28:25	NEW_FLOW_INDX		New Flow (VID) index for In/Out-Band	0

**Table 225: CFP Action Policy Data Register (Page 20h: Address 70h–75h) (Cont.)**

<b>Bit</b>	<b>Name</b>	<b>R/W</b>	<b>Description</b>	<b>Default</b>
24	CHNG_DSCP_IB		Change DSCP for In-Band.(modify packet) <ul style="list-style-type: none"> <li>• 1 = will change DSCP field of the corresponding packet</li> <li>• 0 = Don't care New_DSCP_IB content for this policy</li> </ul>	0
23:18	NEW_DSCP_IB		New DSCP value for In-Band The value will replace the original DSCP value if CHNG_DSCP_IB is set	0
17	CHNG_PCP		Change 802.1p header for In/Out-Band <ul style="list-style-type: none"> <li>• 1 = Replace 802.1p field of the corresponding packet with NEW_PCP</li> <li>• 0 = Ignore New_PCP content for this policy</li> </ul>	0
16:14	NEW_PCP	RO	New 802.1p header for In/Out-Band This value will replace the original 802.1p tag if CHNG_PCP is set.	0
13	CHNG_QOS	R/W	Update Priority for In/Out-Band. <ul style="list-style-type: none"> <li>• 1 = Replace the priority of the corresponding frame with NEW_QOS.</li> <li>• 0 = Ignore NEW_QOS content for this policy.</li> </ul>	0
12:11	NEW_QOS	RO	Priority map for In/Out-Band (Ethernet port only) The priority to be changed to if CHNG_QOS is set	0
10	CHNG_QOS_IMP	R/W	Change QoS for In/Out-Band (IMP port only, do not modify packet) <ul style="list-style-type: none"> <li>• 1 = Replace the priority of the corresponding frame with NEW_QOS_IMP.</li> <li>• 0 = Ignore NEW_QOS_IMP content for this policy.</li> </ul>	0
9:8	NEW_QOS_IMP	R/W	Priority Map for In/Out-Band (IMP port only) The priority to be changed to if CHG_QOS_IMP is asserted.	0
7:6	CHNG_FWD_IB[1:0]	R/W	Change Forward Map for In-Band <ul style="list-style-type: none"> <li>• 00: Forward based on ARL forward map with no change</li> <li>• 01: Use NEW_FWD_IB[5:0] as final forward map.</li> <li>• 10: ARL forward map is ORed with NEW_FWD_IB[5:0] to get the final forward map</li> <li>• 11: Explicit actions (such as switching drop, copy CPU, mirror) are defined by NEW_FWD_IB[5:0]</li> </ul>	0

**Table 225: CFP Action Policy Data Register (Page 20h: Address 70h–75h) (Cont.)**

<b>Bit</b>	<b>Name</b>	<b>R/W</b>	<b>Description</b>	<b>Default</b>
5:0	NEW_FWD_IB[5:0]	R/W	<p>New Destination Port Number for In-Band.</p> <ul style="list-style-type: none"> <li>• When bits[38:37] = 01 or 10, NEW_FWD_IB[5:0] is defined as: <ul style="list-style-type: none"> <li>– 0~23 = Reserved</li> <li>– 24 = Port 0</li> <li>– ...</li> <li>– 47 = Port 23</li> <li>–</li> <li>– 48 = IMP</li> <li>– 49 = Giga Port G0</li> <li>– 50 = Giga Port G1</li> <li>– 51 ~ 62 = Reserved</li> <li>– 63 = Flood to all linked-up ports.</li> </ul> </li> <li>• When bits[38:37] = 11, NEW_FWD_IB[5:0] defines the new actions: <ul style="list-style-type: none"> <li>– 0~55 = Reserved</li> <li>– 56 = Forward packet based on ARL forward map</li> <li>– 57 = Forward packet based on ARL and copy to Mirror Capture port</li> <li>– 58 = Forward packet based on ARL and copy to IMP port</li> <li>– 59 = Forward packet based on ARL and to both IMP and Mirror Capture ports</li> <li>– 60 = Drop the packet</li> <li>– 61 = Forward packet to Mirror Capture port only</li> <li>– 62 = Forward packet to IMP port only</li> <li>– 63 = Forward packet to both IMP and Mirror Capture ports.</li> </ul> </li> </ul>	0

## CFP Rate Meter Configuration Register (Page 20h/Addr 80h–83h)

*Table 226: CFP Rate Meter Configuration Register (Page 20h: Address 80h–83h)*

Bit	Name	R/W	Description	Default
31:22	RSVD	RO	Reserved. Write default. Ignore on read.	0
21:15	BKT_SIZE	R/W	Bucket Size Unit = 8KB Bucket size = 8KB x BKT_SIZE <ul style="list-style-type: none"> <li>• 000 = 0000 KB</li> <li>• 001 = 0008 KB</li> <li>• 002 = 0016 KB</li> <li>• .....</li> <li>• 127 = 1016 KB</li> </ul>	0
14	RFRSH_UNIT	R/W	Refresh Unit <ul style="list-style-type: none"> <li>• 1 = 1 Mbps</li> <li>• 0 = 62.5 Kbps</li> </ul>	0
13:0	RFRSH_CNT	R/W	Refresh count <ul style="list-style-type: none"> <li>• 1: Rate = 1 Mbps x RFRSH_CNT</li> <li>• 0: Rate = 62.5Kbps x RFRSH_CNT</li> </ul>	0

## CFP Rate Inband Statistic Register (Page 20h/Addr 90h–93h)

*Table 227: CFP Rate Inband Statistic Register (Page 20h: Address 90h–93h)*

Bit	Name	R/W	Description	Default
31:0	INBAND_CNTR	R/W	Inband Counter. Data to be read from or written to the Inband rate counter.	0

## CFP Rate Outband Statistic Register (Page 20h/Addr 94h–97h)

*Table 228: CFP Rate Outband Statistic Register (Page 20h: Address 94h–97h)*

Bit	Name	R/W	Description	Default
31:0	OUTBAND_CNTR	R/W	Outband Counter. Data to be read from or written to the Outband rate counter.	0

## Page 21h: CFP Control Registers

**Table 229: CFP Control Registers (Page 21h)**

<b>Address</b>	<b>Bits</b>	<b>Register Name</b>
00h–07h	8	“CFP Global Control Register (Page 21h/Addr 00h)” on page 272
08h–09h	8	“Range Checker Control Register (Page 21h/Addr 08h)” on page 272
0Ah–0Fh	Reserved	
10h–11h	16	“Global CFP Control1 Register (Page 21h/Addr 10h)” on page 274
20h–23h	64	“CFP Enable Control Register (Page 21h/Addr 20h–27h)” on page 274
30h–33h	32	“VID Range Checker 0 Register (Page 21h/Addr 30h)” on page 274
34h–37h	32	“VID Range Checker 1 Register (Page 21h/Addr 34h)” on page 274
38h–3Bh	32	“VID Range Checker 2 Register (Page 21h/Addr 38h)” on page 275
3Ch–3Fh	32	“VID Range Checker 3 Register (Page 21h/Addr 3Ch)” on page 275
40h–43h	32	“L4 Port Range Checker 0 Register (Page 21h/Addr 40h)” on page 275
44h–47h	32	“L4 Port Range Checker 1 Register (Page 21h/Addr 44h)” on page 275
48h–4Bh	32	“L4 Port Range Checker 2 Register (Page 21h/Addr 48h)” on page 275
4Ch–4Fh	32	“L4 Port Range Checker 3 Register (Page 21h/Addr 4Ch)” on page 276
50h	16	“Other Checker Register (Page 21h/Addr 50h)” on page 276
58h–EFh	Reserved	
F0h–F7h	–	SPI Data I/O[0:7]
F8h–FDh	Reserved	
FEh	–	SPI Status
FFh	8	Page Register

## CFP Global Control Register (Page 21h/Addr 00h)

Table 230: CFP Global Control Register (Page 21h: Address 00h)

Bit	Name	R/W	Description	Default
7:6	SLICE2_PRI	R/W	Slice 2 priority	0
5:4	SLICE1_PRI	R/W	Slice 1 priority	0
3:2	SLICE0_PRI	R/W	Slice 0 priority	0
1	AGGREGATION_CTRL	R/W	CFP Aggregation control <ul style="list-style-type: none"> <li>1 = if the action is flood, will flood to all the ports. So Aggregation ports will have multiple copies.</li> <li>0 = if the action is flood, will only forward one copy in each aggregation group.</li> </ul> <p><b>Note:</b> In this mode it will not do the load balancing, it is up to the user to designate the ports to send the frame.</p>	0
0	VLAN_CTRL	R/W	CFP VLAN control <ul style="list-style-type: none"> <li>1 = if the action is flood, will flood to all the ports. it does not care VLAN security.</li> <li>0 = if the action is flood, will only forward to member set which the packet belong to.</li> </ul>	0

## Range Checker Control Register (Page 21h/Addr 08h)

Table 231: Range Checker Control Register (Page 21h/Addr 08h)

Bit	Name	R/W	Description	Default
7:5	RSVD	–	Reserved	00h
4	CHG_VID_FFF_CTRL	R/W	Change VID Control bit. This bit is used when the entries of FLOW2VLAN are set to 12'hfff. <ul style="list-style-type: none"> <li>0 = when the new VID reading from FLOW2VLAN is 12'hfff, it will maintain the original VID. (i.e., does not change VID).</li> <li>1 = when the new VID reading from FLOW2VLAN is 12'hfff, it will change VID to 12'hfff.</li> </ul>	0
3	RNG_CHKR_CTRL_3	R/W	Range Check Control 3 <ul style="list-style-type: none"> <li>1 = L4 Destination port</li> <li>0 = L4 Source port</li> </ul>	0
2	RNG_CHKR_CTRL_2	R/W	Range Check Control 2 <ul style="list-style-type: none"> <li>1 = L4 Destination port</li> <li>0 = L4 Source port</li> </ul>	0
1	RNG_CHKR_CTRL_1	R/W	Range Check Control 1 <ul style="list-style-type: none"> <li>1 = L4 Destination port</li> <li>0 = L4 Source port</li> </ul>	0



**Table 231: Range Checker Control Register (Page 21h/Addr 08h)**

<b>Bit</b>	<b>Name</b>	<b>R/W</b>	<b>Description</b>	<b>Default</b>
0	RNG_CHKR_CTRL_0	R/W	Range Check Control 0 <ul style="list-style-type: none"><li>• 1 = L4 Destination port</li><li>• 0 = L4 Source port</li></ul>	0

Broadcom Confidential

## Global CFP Control1 Register (Page 21h/Addr 10h)

**Table 232: CFP Global Control 1 Register (Page 21h: Address 10h–11h)**

Bit	Name	R/W	Description	Default
15:0	ISP_VLAN_DELIMITER	R/W	Delimiter of ISP Tagged frame. <b>Note:</b> The Delimiter of .1Q tagged frame is 0x8100	0x9100

## CFP Enable Control Register (Page 21h/Addr 20h–27h)

**Table 233: CFP Enable Control Register (Page 21h: Address 20h–27h)**

Bit	Name	R/W	Description	Default
63:51	RSVD	–	Reserved	0
50:24	CFP_CTRL_EN	R/W	CFP Enable Control Register bits When a bit is set to '1', enable the CFP feature of the corresponding port. <ul style="list-style-type: none"> <li>Bit 50 = GigaPort G1</li> <li>Bit 49 = GigaPort G0</li> <li>Bit 48 = IMP.</li> <li>Bits 47:24 = 10/100 ports [port 23–port 0]</li> </ul>	0
23:0	RSVD	–	Reserved	0

## VID Range Checker 0 Register (Page 21h/Addr 30h)

**Table 234: VID Range Checker 0 Register (Page 21h: Address 30h–33h)**

Bit	Name	R/W	Description	Default
31:28	RSVD	–	Reserved	0
27:16	UPPR_LMT	R/W	Upper limit value	0
15:12	RSVD	–	Reserved	0
11:0	LOWR_LMT	R/W	Lower limit value	0

## VID Range Checker 1 Register (Page 21h/Addr 34h)

**Table 235: VID Range Checker 1 Register (Page 21h: Address 34h–37h)**

Bit	Name	R/W	Description	Default
31:28	RSVD	–	Reserved	0
27:16	UPPR_LMT	R/W	Upper limit value	0
15:12	RSVD	–	Reserved	0
11:0	LOWR_LMT	R/W	Lower limit value	0

## VID Range Checker 2 Register (Page 21h/Addr 38h)

Table 236: VID Range Checker 2 Register (Page 21h: Address 38h–3Bh)

Bit	Name	R/W	Description	Default
31:28	RSVD	–	Reserved	0
27:16	UPPR_LMT	R/W	Upper limit value	0
15:12	RSVD	–	Reserved	0
11:0	LOWR_LMT	R/W	Lower limit value	0

## VID Range Checker 3 Register (Page 21h/Addr 3Ch)

Table 237: VID Range Checker 3 Register (Page 21h: Address 3Ch–3Fh)

Bit	Name	R/W	Description	Default
31:28	RSVD	–	Reserved	0
27:16	UPPR_LMT	R/W	Upper limit value	0
15:12	RSVD	–	Reserved	0
11:0	LOWR_LMT	R/W	Lower limit value	0

## L4 Port Range Checker 0 Register (Page 21h/Addr 40h)

Table 238: L4 Port Range Checker 0 Register (Page 21h: Address 40h–43h)

Bit	Name	R/W	Description	Default
31:16	UPPR_LMT	R/W	Upper limit value	0
15:0	LOWR_LMT	R/W	Lower limit value	0

## L4 Port Range Checker 1 Register (Page 21h/Addr 44h)

Table 239: L4 Port Range Checker 1 Register (Page 21h: Address 44h–47h)

Bit	Name	R/W	Description	Default
31:16	UPPR_LMT	R/W	Upper limit value	0
15:0	LOWR_LMT	R/W	Lower limit value	0

## L4 Port Range Checker 2 Register (Page 21h/Addr 48h)

Table 240: L4 Port Range Checker 2 Register (Page 21h: Address 48h–4Bh)

Bit	Name	R/W	Description	Default
31:16	UPPR_LMT	R/W	Upper limit value	0

**Table 240: L4 Port Range Checker 2 Register (Page 21h: Address 48h–4Bh)**

Bit	Name	R/W	Description	Default
15:0	LOWR_LMT	R/W	Lower limit value	0

## L4 Port Range Checker 3 Register (Page 21h/Addr 4Ch)

**Table 241: L4 Port Range Checker 3 Register (Page 21h: Address 4Ch–4Fh)**

Bit	Name	R/W	Description	Default
31:16	UPPR_LMT	R/W	Upper limit value	0
15:0	LOWR_LMT	R/W	Lower limit value	0

## Other Checker Register (Page 21h/Addr 50h)

**Table 242: Other Checker Register (Page 21h: Address 50h–51h)**

Bit	Name	R/W	Description	Default
15:14	RSVD	–	Reserved	
13:10	TCP_HDR_LNGTH	R/W	TCP Header Length	0
9:0	BIG_ICMP	R/W	Big ICMP	0

## Page 22h: CFP UDF Control Registers

**Table 243: CFP UDF Control Registers (Page 22h)**

Address	Bits	Register Name
00h	8	<a href="#">“CFP UDF A0 Control Register (Page 22h/Addr 00h)” on page 278</a>
01h	8	<a href="#">“CFP UDF A1 Control Register (Page 22h/Addr 01h)” on page 278</a>
02h	8	<a href="#">“CFP UDF A2 Control Register (Page 22h/Addr 02h)” on page 278</a>
10h	8	<a href="#">“CFP UDF B0 Control Register (Page 22h/Addr 10h)” on page 279</a>
11h	8	<a href="#">“CFP UDF B1 Control Register (Page 22h/Addr 11h)” on page 279</a>
12h	8	<a href="#">“CFP UDF B2 Control Register (Page 22h/Addr 12h)” on page 279</a>
13h	8	<a href="#">“CFP UDF B3 Control Register (Page 22h/Addr 13h)” on page 280</a>
14h	8	<a href="#">“CFP UDF B4 Control Register (Page 22h/Addr 14h)” on page 280</a>
15h	8	<a href="#">“CFP UDF B5 Control Register (Page 22h/Addr 15h)” on page 281</a>
16h	8	<a href="#">“CFP UDF B6 Control Register (Page 22h/Addr 16h)” on page 281</a>
17h	8	<a href="#">“CFP UDF B7 Control Register (Page 22h/Addr 17h)” on page 281</a>

**Table 243: CFP UDF Control Registers (Page 22h) (Cont.)**

<b>Address</b>	<b>Bits</b>	<b>Register Name</b>
18h	8	"CFP UDF B8 Control Register (Page 22h/Addr 18h)" on page 282
19h	8	"CFP UDF B9 Control Register (Page 22h/Addr 19h)" on page 282
1Ah	8	"CFP UDF B10 Control Register (Page 22h/Addr 1Ah)" on page 283
20h	8	"CFP UDF C0 Control Register (Page 22h/Addr 20h)" on page 283
21h	8	"CFP UDF C1 Control Register (Page 22h/Addr 21h)" on page 283
22h	8	"CFP UDF C2 Control Register (Page 22h/Addr 22h)" on page 284
30h	8	"CFP UDF D0 Control Register (Page 22h/Addr 30h)" on page 284
31h	8	"CFP UDF D1 Control Register (Page 22h/Addr 31h)" on page 285
32h	8	"CFP UDF D2 Control Register (Page 22h/Addr 32h)" on page 285
33h	8	"CFP UDF D3 Control Register (Page 22h/Addr 33h)" on page 285
34h	8	"CFP UDF D4 Control Register (Page 22h/Addr 34h)" on page 286
35h	8	"CFP UDF D5 Control Register (Page 22h/Addr 35h)" on page 286
36h	8	"CFP UDF D6 Control Register (Page 22h/Addr 36h)" on page 287
37h	8	"CFP UDF D7 Control Register (Page 22h/Addr 37h)" on page 287
F0h–F7h	–	SPI Data I/O[0:7]
F8h–FDh	Reserved	
FEh	–	SPI Status
FFh	8	Page Register

## CFP UDF A0 Control Register (Page 22h/Addr 00h)

**Table 244: CFP UDF A0 Control Register (Page 22h: Address 00h)**

Bit	Name	R/W	Description	Default
7:6	UDF_REF_A0	R/W	Flag indicating the type of field for starting address <ul style="list-style-type: none"> <li>• 11 = reserved</li> <li>• 10 = end of IP header (including IPv4 option)</li> <li>• 01 = end of Ether Type</li> <li>• 00 = end of Tag</li> </ul>	0
5:0	UDF_OFFSET_A0	R/W	The offset used for UDF_A0 which is used in Slice 0. The number counts from the reference port of frame. Rx port extracts 16 bits of data from the corresponding location for CFP lookup. Unit: 16 bits (2-bytes)	0

## CFP UDF A1 Control Register (Page 22h/Addr 01h)

**Table 245: CFP UDF A1 Control Register (Page 22h: Address 01h)**

Bit	Name	R/W	Description	Default
7:6	UDF_REF_A1	R/W	Flag indicating the type of field for starting address <ul style="list-style-type: none"> <li>• 11 = reserved</li> <li>• 10 = end of IP header (including IPv4 option)</li> <li>• 01 = end of Ether Type</li> <li>• 00 = end of Tag</li> </ul>	0
5:0	UDF_OFFSET_A1	R/W	The offset used for UDF_A1 which is used in Slice 0. The number counts from the reference port of frame. Rx port extracts 16 bits of data from the corresponding location for CFP lookup. Unit: 16 bits (2-bytes)	0

## CFP UDF A2 Control Register (Page 22h/Addr 02h)

**Table 246: CFP UDF A2 Control Register (Page 22h: Address 02h)**

Bit	Name	R/W	Description	Default
7:6	UDF_REF_A2	R/W	Flag indicating the type of field for starting address <ul style="list-style-type: none"> <li>• 11 = reserved</li> <li>• 10 = end of IP header (including IPv4 option)</li> <li>• 01 = end of Ether Type</li> <li>• 00 = end of Tag</li> </ul>	0
5:0	UDF_OFFSET_A2	R/W	The offset used for UDF_A2 which is used in Slice 0. The number counts from the reference port of frame. Rx port extracts 16 bits data from the corresponding location for CFP lookup. Unit: 16 bits (2-bytes)	0

## CFP UDF B0 Control Register (Page 22h/Addr 10h)

**Table 247: CFP UDF B0 Control Register (Page 22h: Address 10h)**

Bit	Name	R/W	Description	Default
7:6	UDF_REF_B0	R/W	Flag indicating the type of field for starting address <ul style="list-style-type: none"> <li>• 11 = reserved</li> <li>• 10 = end of IP header (including IPv4 option)</li> <li>• 01 = end of Ether Type</li> <li>• 00 = end of Tag</li> </ul>	0
5:0	UDF_OFFSET_B0	R/W	The offset used for UDF_B0 which is used in Slice 1. The number counts from the reference port of frame. Rx port extracts 16 bits of data from the corresponding location for CFP lookup. Unit: 16 bits (2-bytes)	0

## CFP UDF B1 Control Register (Page 22h/Addr 11h)

**Table 248: CFP UDF B1 Control Register (Page 22h: Address 11h)**

Bit	Name	R/W	Description	Default
7:6	UDF_REF_B1	R/W	Flag indicating the type of field for starting address <ul style="list-style-type: none"> <li>• 11 = reserved</li> <li>• 10 = end of IP header (including IPv4 option)</li> <li>• 01 = end of Ether Type</li> <li>• 00 = end of Tag</li> </ul>	0
5:0	UDF_OFFSET_B1	R/W	The offset used for UDF_B1 which is used in Slice 1. The number counts from the reference port of frame. Rx port extracts 16 bits of data from the corresponding location for CFP lookup. Unit: 16 bits (2-bytes)	0

## CFP UDF B2 Control Register (Page 22h/Addr 12h)

**Table 249: CFP UDF B2 Control Register (Page 22h: Address 12h)**

Bit	Name	R/W	Description	Default
7:6	UDF_REF_B2	R/W	Flag indicating the type of field for starting address <ul style="list-style-type: none"> <li>• 11 = reserved</li> <li>• 10 = end of IP header (including IPv4 option)</li> <li>• 01 = end of Ether Type</li> <li>• 00 = end of Tag</li> </ul>	0

**Table 249: CFP UDF B2 Control Register (Page 22h: Address 12h)**

Bit	Name	R/W	Description	Default
5:0	UDF_OFFSET_B2	R/W	The offset used for UDF_B2 which is used in Slice 1. The number counts from the reference port of frame. Rx port extracts 16 bits of data from the corresponding location for CFP lookup. Unit: 16 bits (2-bytes)	0

## CFP UDF B3 Control Register (Page 22h/Addr 13h)

**Table 250: CFP UDF B3 Control Register (Page 22h: Address 13h)**

Bit	Name	R/W	Description	Default
7:6	UDF_REF_B3	R/W	Flag indicating the type of field for starting address <ul style="list-style-type: none"> <li>• 11 = reserved</li> <li>• 10 = end of IP header (including IPv4 option)</li> <li>• 01 = end of Ether Type</li> <li>• 00 = end of Tag</li> </ul>	0
5:0	UDF_OFFSET_B3	R/W	The offset used for UDF_B3 which is used in Slice 1. The number counts from the reference port of frame. Rx port extracts 16 bits of data from the corresponding location for CFP lookup. Unit: 16 bits (2-bytes)	0

## CFP UDF B4 Control Register (Page 22h/Addr 14h)

**Table 251: CFP UDF B4 Control Register (Page 22h: Address 14h)**

Bit	Name	R/W	Description	Default
7:6	UDF_REF_B4	R/W	Flag indicating the type of field for starting address <ul style="list-style-type: none"> <li>• 11 = reserved</li> <li>• 10 = end of IP header (including IPv4 option)</li> <li>• 01 = end of Ether Type</li> <li>• 00 = end of Tag</li> </ul>	0
5:0	UDF_OFFSET_B4	R/W	The offset used for UDF_B4 which is used in Slice 1. The number counts from the reference port of frame. Rx port extracts 16 bits of data from the corresponding location for CFP lookup. Unit: 16 bits (2-bytes)	0



## CFP UDF B5 Control Register (Page 22h/Addr 15h)

**Table 252: CFP UDF B5 Control Register (Page 22h: Address 15h)**

Bit	Name	R/W	Description	Default
7:6	UDF_REF_B5	R/W	Flag indicating the type of field for starting address <ul style="list-style-type: none"> <li>• 11 = reserved</li> <li>• 10 = end of IP header (including IPv4 option)</li> <li>• 01 = end of Ether Type</li> <li>• 00 = end of Tag</li> </ul>	0
5:0	UDF_OFFSET_B5	R/W	The offset used for UDF_B5 which is used in Slice 1. The number counts from the reference port of frame. Rx port extracts 16 bits of data from the corresponding location for CFP lookup. Unit: 16 bits (2-bytes)	0

## CFP UDF B6 Control Register (Page 22h/Addr 16h)

**Table 253: CFP UDF B6 Control Register (Page 22h: Address 16h)**

Bit	Name	R/W	Description	Default
7:6	UDF_REF_B6	R/W	Flag indicating the type of field for starting address <ul style="list-style-type: none"> <li>• 11 = reserved</li> <li>• 10 = end of IP header (including IPv4 option)</li> <li>• 01 = end of Ether Type</li> <li>• 00 = end of Tag</li> </ul>	0
5:0	UDF_OFFSET_B6	R/W	The offset used for UDF_B6 which is used in Slice 1. The number counts from the reference port of frame. Rx port extracts 16 bits of data from the corresponding location for CFP lookup. Unit: 16 bits (2-bytes)	0

## CFP UDF B7 Control Register (Page 22h/Addr 17h)

**Table 254: CFP UDF B7 Control Register (Page 22h: Address 17h)**

Bit	Name	R/W	Description	Default
7:6	UDF_REF_B7	R/W	Flag indicating the type of field for starting address <ul style="list-style-type: none"> <li>• 11 = reserved</li> <li>• 10 = end of IP header (including IPv4 option)</li> <li>• 01 = end of Ether Type</li> <li>• 00 = end of Tag</li> </ul>	0

**Table 254: CFP UDF B7 Control Register (Page 22h: Address 17h)**

<b>Bit</b>	<b>Name</b>	<b>R/W</b>	<b>Description</b>	<b>Default</b>
5:0	UDF_OFFSET_B7	R/W	The offset used for UDF_B7 which is used in Slice 1. The number counts from the reference port of frame. Rx port extracts 16 bits of data from the corresponding location for CFP lookup. Unit: 16 bits (2-bytes)	0

## CFP UDF B8 Control Register (Page 22h/Addr 18h)

**Table 255: CFP UDF B8 Control Register (Page 22h: Address 18h)**

<b>Bit</b>	<b>Name</b>	<b>R/W</b>	<b>Description</b>	<b>Default</b>
7:6	UDF_REF_B8	R/W	Flag indicating the type of field for starting address <ul style="list-style-type: none"> <li>• 11 = reserved</li> <li>• 10 = end of IP header (including IPv4 option)</li> <li>• 01 = end of Ether Type</li> <li>• 00 = end of Tag</li> </ul>	0
5:0	UDF_OFFSET_B8	R/W	The offset used for UDF_B8 which is used in Slice1. The number counts from the reference port of frame. Rx port extracts 16 bits of data from the corresponding location for CFP lookup. Unit: 16 bits (2-bytes)	0

## CFP UDF B9 Control Register (Page 22h/Addr 19h)

**Table 256: CFP UDF B9 Control Register (Page 22h: Address 19h)**

<b>Bit</b>	<b>Name</b>	<b>R/W</b>	<b>Description</b>	<b>Default</b>
7:6	UDF_REF_B9	R/W	Flag indicating the type of field for starting address <ul style="list-style-type: none"> <li>• 11 = reserved</li> <li>• 10 = end of IP header (including IPv4 option)</li> <li>• 01 = end of Ether Type</li> <li>• 00 = end of Tag</li> </ul>	0
5:0	UDF_OFFSET_B9	R/W	The offset used for UDF_B9 which is used in Slice 1. The number counts from the reference port of frame. Rx port extracts 16 bits of data from the corresponding location for CFP lookup. Unit: 16 bits (2-bytes)	0

## CFP UDF B10 Control Register (Page 22h/Addr 1Ah)

*Table 257: CFP UDF B10 Control Register (Page 22h: Address 1Ah)*

<i>Bit</i>	<i>Name</i>	<i>R/W</i>	<i>Description</i>	<i>Default</i>
7:6	UDF_REF_B10	R/W	Flag indicating the type of field for starting address <ul style="list-style-type: none"> <li>• 11 = reserved</li> <li>• 10 = end of IP header (including IPv4 option)</li> <li>• 01 = end of Ether Type</li> <li>• 00 = end of Tag</li> </ul>	0
5:0	UDF_OFFSET_B10	R/W	The offset used for UDF_B10 which is used in Slice 1. The number counts from the reference port of frame. Rx port extracts 16 bits of data from the corresponding location for CFP lookup. Unit: 16 bits (2-bytes)	0

## CFP UDF C0 Control Register (Page 22h/Addr 20h)

*Table 258: CFP UDF C0 Control Register (Page 22h: Address 20h)*

<i>Bit</i>	<i>Name</i>	<i>R/W</i>	<i>Description</i>	<i>Default</i>
7:6	UDF_REF_C0	R/W	Flag indicating the type of field for starting address <ul style="list-style-type: none"> <li>• 11 = start of packet (Revision B silicon)</li> <li>• 11 = reserved (Revision A silicon)</li> <li>• 10 = end of IP header (including IPv4 option)</li> <li>• 01 = end of Ether Type</li> <li>• 00 = end of Tag</li> </ul>	0
5:0	UDF_OFFSET_C0	R/W	The offset used for UDF_C0 which is used in Slice 2. The number counts from the reference port of frame. Rx port extracts 16 bits of data from the corresponding location for CFP lookup. Unit: 16 bits (2-bytes)	0

## CFP UDF C1 Control Register (Page 22h/Addr 21h)

*Table 259: CFP UDF C1 Control Register (Page 22h: Address 21h)*

<i>Bit</i>	<i>Name</i>	<i>R/W</i>	<i>Description</i>	<i>Default</i>
7:6	UDF_REF_C1	R/W	Flag indicating the type of field for starting address <ul style="list-style-type: none"> <li>• 11 = start of packet (Revision B silicon)</li> <li>• 11 = reserved (Revision A silicon)</li> <li>• 10 = end of IP header (including IPv4 option)</li> <li>• 01 = end of Ether Type</li> <li>• 00 = end of Tag</li> </ul>	0

**Table 259: CFP UDF C1 Control Register (Page 22h: Address 21h)**

<b>Bit</b>	<b>Name</b>	<b>R/W</b>	<b>Description</b>	<b>Default</b>
5:0	UDF_OFFSET_C1	R/W	The offset used for UDF_C1 which is used in Slice 2. The number counts from the reference port of frame. Rx port extracts 16 bits of data from the corresponding location for CFP lookup. Unit: 16 bits (2-bytes)	0

## CFP UDF C2 Control Register (Page 22h/Addr 22h)

**Table 260: CFP UDF C2 Control Register (Page 22h: Address 22h)**

<b>Bit</b>	<b>Name</b>	<b>R/W</b>	<b>Description</b>	<b>Default</b>
7:6	UDF_REF_C2	R/W	Flag indicating the type of field for starting address <ul style="list-style-type: none"> <li>• 11 = start of packet (Revision B silicon)</li> <li>• 11 = reserved (Revision A silicon)</li> <li>• 10 = end of IP header (including IPv4 option)</li> <li>• 01 = end of Ether Type</li> <li>• 00 = end of Tag</li> </ul>	0
5:0	UDF_OFFSET_C2	R/W	The offset used for UDF_C2 which is used in Slice 2. The number counts from the reference port of frame. Rx port extracts 16 bits of data from the corresponding location for CFP lookup. Unit: 16 bits (2-bytes)	0

## CFP UDF D0 Control Register (Page 22h/Addr 30h)

**Table 261: CFP UDF D0 Control Register (Page 22h: Address 30h)**

<b>Bit</b>	<b>Name</b>	<b>R/W</b>	<b>Description</b>	<b>Default</b>
7:6	UDF_REF_D0	R/W	Flag indicating the type of field for starting address <ul style="list-style-type: none"> <li>• 11 = reserved</li> <li>• 10 = end of IP header (including IPv4 option)</li> <li>• 01 = end of Ether Type</li> <li>• 00 = end of Tag</li> </ul>	0
5:0	UDF_OFFSET_D0	R/W	The offset used for UDF_D0 which is used in Slice 2. The number counts from the reference port of frame. Rx port extracts 16 bits of data from the corresponding location for CFP lookup. Unit: 32 bits (4-bytes)	0

## CFP UDF D1 Control Register (Page 22h/Addr 31h)

**Table 262: CFP UDF D1 Control Register (Page 22h: Address 31h)**

Bit	Name	R/W	Description	Default
7:6	UDF_REF_D1	R/W	Flag indicating the type of field for starting address <ul style="list-style-type: none"> <li>• 11 = reserved</li> <li>• 10 = end of IP header (including IPv4 option)</li> <li>• 01 = end of Ether Type</li> <li>• 00 = end of Tag</li> </ul>	0
5:0	UDF_OFFSET_D1	R/W	The offset used for UDF_D1 which is used in Slice 2. The number counts from the reference port of frame. Rx port extracts 16 bits of data from the corresponding location for CFP lookup. Unit: 32 bits (4-bytes)	0

## CFP UDF D2 Control Register (Page 22h/Addr 32h)

**Table 263: CFP UDF D2 Control Register (Page 22h: Address 32h)**

Bit	Name	R/W	Description	Default
7:6	UDF_REF_D2	R/W	Flag indicating the type of field for starting address <ul style="list-style-type: none"> <li>• 11 = reserved</li> <li>• 10 = end of IP header (including IPv4 option)</li> <li>• 01 = end of Ether Type</li> <li>• 00 = end of Tag</li> </ul>	0
5:0	UDF_OFFSET_D2	R/W	The offset used for UDF_D2 which is used in Slice 2. The number counts from the reference port of frame. Rx port extracts 16 bits of data from the corresponding location for CFP lookup. Unit: 32 bits (4-bytes)	0

## CFP UDF D3 Control Register (Page 22h/Addr 33h)

**Table 264: CFP UDF D3 Control Register (Page 22h: Address 33h)**

Bit	Name	R/W	Description	Default
7:6	UDF_REF_D3	R/W	Flag indicating the type of field for starting address <ul style="list-style-type: none"> <li>• 11 = reserved</li> <li>• 10 = end of IP header (including IPv4 option)</li> <li>• 01 = end of Ether Type</li> <li>• 00 = end of Tag</li> </ul>	0

**Table 264: CFP UDF D3 Control Register (Page 22h: Address 33h)**

<b>Bit</b>	<b>Name</b>	<b>R/W</b>	<b>Description</b>	<b>Default</b>
5:0	UDF_OFFSET_D3	R/W	The offset used for UDF_D3 which is used in Slice 2. The number counts from the reference port of frame. Rx port extracts 16 bits of data from the corresponding location for CFP lookup. Unit: 32 bits (4-bytes)	0

## CFP UDF D4 Control Register (Page 22h/Addr 34h)

**Table 265: CFP UDF D4 Control Register (Page 22h: Address 34h)**

<b>Bit</b>	<b>Name</b>	<b>R/W</b>	<b>Description</b>	<b>Default</b>
7:6	UDF_REF_D4	R/W	Flag indicating the type of field for starting address <ul style="list-style-type: none"> <li>• 11 = reserved</li> <li>• 10 = end of IP header (including IPv4 option)</li> <li>• 01 = end of Ether Type</li> <li>• 00 = end of Tag</li> </ul>	0
5:0	UDF_OFFSET_D4	R/W	The offset used for UDF_D4 which is used in Slice 2. The number counts from the reference port of frame. Rx port extracts 16 bits of data from the corresponding location for CFP lookup. Unit: 32 bits (4-bytes)	0

## CFP UDF D5 Control Register (Page 22h/Addr 35h)

**Table 266: CFP UDF D5 Control Register (Page 22h: Address 35h)**

<b>Bit</b>	<b>Name</b>	<b>R/W</b>	<b>Description</b>	<b>Default</b>
7:6	UDF_REF_D5	R/W	Flag indicating the type of field for starting address <ul style="list-style-type: none"> <li>• 11 = reserved</li> <li>• 10 = end of IP header (including IPv4 option)</li> <li>• 01 = end of Ether Type</li> <li>• 00 = end of Tag</li> </ul>	0
5:0	UDF_OFFSET_D5	R/W	The offset used for UDF_D5 which is used in Slice 2. The number counts from the reference port of frame. Rx port extracts 16 bits of data from the corresponding location for CFP lookup. Unit: 32 bits (4-bytes)	0

## CFP UDF D6 Control Register (Page 22h/Addr 36h)

*Table 267: CFP UDF D6 Control Register (Page 22h: Address 36h)*

<b>Bit</b>	<b>Name</b>	<b>R/W</b>	<b>Description</b>	<b>Default</b>
7:6	UDF_REF_D6	R/W	Flag indicating the type of field for starting address <ul style="list-style-type: none"> <li>• 11 = reserved</li> <li>• 10 = end of IP header (including IPv4 option)</li> <li>• 01 = end of Ether Type</li> <li>• 00 = end of Tag</li> </ul>	0
5:0	UDF_OFFSET_D6	R/W	The offset used for UDF_D6 which is used in Slice 2. The number counts from the reference port of frame. Rx port extracts 16 bits of data from the corresponding location for CFP lookup. Unit: 32 bits (4-bytes)	0

## CFP UDF D7 Control Register (Page 22h/Addr 37h)

*Table 268: CFP UDF D7 Control Register (Page 22h: Address 37h)*

<b>Bit</b>	<b>Name</b>	<b>R/W</b>	<b>Description</b>	<b>Default</b>
7:6	UDF_REF_D7	R/W	Flag indicating the type of field for starting address <ul style="list-style-type: none"> <li>• 11 = reserved</li> <li>• 10 = end of IP header (including IPv4 option)</li> <li>• 01 = end of Ether Type</li> <li>• 00 = end of Tag</li> </ul>	0
5:0	UDF_OFFSET_D7	R/W	The offset used for UDF_D7 which is used in Slice 2. The number counts from the reference port of frame. Rx port extracts 16 bits of data from the corresponding location for CFP lookup. Unit: 32 bits (4-bytes)	0

## Page 30h: QoS Registers

**Table 269: QoS Registers (Page 30h)**

<b>Address</b>	<b>Bits</b>	<b>Description</b>
00h–0Fh	Reserved	
10h–17h	64	“QoS Control Register (Page 30h/Addr 10h–17h)” on page 289
18h–1Fh	64	“QoS 802.1p Enable Register (Page 30h/Addr 18h–1Fh)” on page 290
20h–27h	64	“QoS DiffServ Enable Register (Page 30h/Addr 20h–27h)” on page 291
28h–2Fh	64	“QoS Pause Enable Register (Page 30h/Addr 28h–2Fh)” on page 292
30h–31h	16	“Priority Threshold Register (Page 30h/Addr 30h–31h)” on page 292
–	Reserved	
40h–47h	64	“DiffServ DSCP Priority Register (Page 30h/Addr 40h–4Fh)” on page 293
48h–4Fh	64	DiffServ DSCP Priority register 2
58h–5Fh	16	“QoS Reason Code Enable Register (Page 30h/Addr 58h–59h)” on page 293
60h	Reserved	
F0h–F7h	64	SPI Data I/O[0:7]
F8h–FDh	Reserved	
FEh	8	SPI Status
FFh	8	Page Register



## QoS Control Register (Page 30h/Addr 10h–17h)

Table 270: QoS Control Register (Pages: 30h, Address 10h–17h)

Bit	Name	R/W	Description	Default
63	CPU Control Enable	R/W	<ul style="list-style-type: none"> <li>1 = Register values control the port-based priority settings. This includes:               <ul style="list-style-type: none"> <li>– QOS_Enable setting (bit 59:58 of this register).</li> <li>– Flow control enable/disable is controlled on a per- port basis in the “<a href="#">QoS Pause Enable Register (Page 30h/Addr 28h–2Fh)</a>” on page 292.</li> </ul> </li> <li>0 = Reserved.</li> </ul>	1
62:61	RSVD	RO	Reserved Write default. Ignore on read.	0
60	dis_autoset_qosreg	RW	Disable Automatically Set QoS Thresholds This bit selects the values to use for control bits/ thresholds defined in Page 0Ah for QoS On/Off. <ul style="list-style-type: none"> <li>1 = Set this bit if custom MMU setting is desired. User is responsible to program the desired values for Page 0Ah manually for both QoS On / Off.</li> <li>0 = The default values for Page 0Ah are set automatically for QoS On / Off.</li> </ul>	0
59:58	QOS_Enable	R/W	Select the number of priority queues. <ul style="list-style-type: none"> <li>11 = When CPU Control Enable (bit 63) is asserted, setting these bits to 11 enables the four-queue QoS function.</li> <li>10 = Reserved</li> <li>01 = Reserved</li> <li>00 = When CPU Control Enable (bit 63) is asserted, setting these bits to 00 disables QoS and enables the single-queue function.</li> </ul>	00
57:2	RSVD	RO	Reserved Write default. Ignore on read.	0
1:0	PRI_SEL	R/W	Priority Scheduling <ul style="list-style-type: none"> <li>00: 4 WRR (Default)</li> <li>01: 1 SP - 3 WRR</li> <li>10: 2 SP - 2 WRR</li> <li>11: 4 SP</li> </ul>	00

## QoS 802.1p Enable Register (Page 30h/Addr 18h–1Fh)

*Table 271: QoS 802.1p Enable Register (Page 30h: Address 18h–1Fh)*

<b>Bit</b>	<b>Name</b>	<b>R/W</b>	<b>Description</b>	<b>Default</b>
63:51	RSVD	RO	Reserved Write default. Ignore on read.	0
50:24	QOS_1P_EN	R/W	802.1p QoS enable bit for per-port. A 27-bit mask which selectively allows any port with its corresponding bit set, to enable 802.1p QoS. <ul style="list-style-type: none"> <li>• Bit 50 = GigaPort G1</li> <li>• Bit 49 = GigaPort G0</li> <li>• Bit 48 = IMP</li> <li>• Bits 47:24 = 10/100 ports [port 23–port 0]</li> </ul>	6-FFFF-FF
23:0	RSVD	–	Reserved	0

## QoS DiffServ Enable Register (Page 30h/Addr 20h–27h)

*Table 272: QoS DiffServ Enable Register (Page 30h: Address 20h–27h)*

<b>Bit</b>	<b>Name</b>	<b>R/W</b>	<b>Description</b>	<b>Default</b>
63:51	RSVD	RO	Reserved Write default. Ignore on read.	0
50:24	QoS_Diff_EN	R/W	DiffServ QoS enable bit for per-port. A 27-bit mask which selectively allows any port with its corresponding bit set, to enable DiffServ QoS. <ul style="list-style-type: none"> <li>• Bit 50 = GigaPort G1</li> <li>• Bit 49 = GigaPort G0</li> <li>• Bit 48 = IMP</li> <li>• Bits 47:24 = 10/100 ports [port 23–port 0]</li> </ul>	0
23:0	RSVD	–	Reserved	0

## QoS Pause Enable Register (Page 30h/Addr 28h–2Fh)

**Table 273: QoS Pause Enable Register (Page 30h: Address 28h–2Fh)**

Bit	Name	R/W	Description	Default
63:51	RSVD	RO	Reserved Write default. Ignore on read.	0
50:49	GE_PAUSE_EN	R/W	Per port QoS PAUSE Enable bit. <ul style="list-style-type: none"> <li>Bit 50 = GigaPort G1</li> <li>Bit 49 = GigaPort G0</li> </ul>	0
48	IMP_PAUSE_EN	R/W	Per port QoS PAUSE Enable bit. <ul style="list-style-type: none"> <li>Bit 48 = IMP or as a network port.</li> </ul>	0
47:24	FE_PAUSE_EN	R/W	Per port QoS PAUSE Enable bit. A 24-bit mask which selectively allows any port with its corresponding bit set, to enable PAUSE. Bits 47:24 = 10/100 ports [port 23–port 0]	0
23:0	RSVD	–	Reserved	0

Note: When software control of QoS is enabled by asserting the QOS\_Enable, bits[59:58] of the “[QoS Control Register \(Page 30h/Addr 10h–17h\)](#)” on page 289, the QoS PAUSE Enable of individual port is controlled by setting:

- 0 = Half-duplex back pressure and full-duplex flow control are disabled. Only dropping of frames is supported on the given port.
- 1 = Individual port supports half-duplex back pressure and full-duplex flow control.

However, the per port PAUSE\_EN state (if enabled) allows transmission of the Pause frame only from the switch when buffers are near capacity. When the link partner sends Pause frame, the switch does not pause transmission. Any change of state on PAUSE\_EN has neither effect on the “[Pause Status Summary Register \(Page 02h/Addr 30h–37h\)](#)” on page 193.

## Priority Threshold Register (Page 30h/Addr 30h–31h)

**Table 274: Priority Threshold Register (Page 30h: Address 30h–31h)**

Bit	Name	R/W	Description	Default
15:14	802.1p Priority Tag 111	R/W	These two bits are used to assign priority queue of tag 111.	3h
13:12	802.1p Priority Tag 110	R/W	These two bits are used to assign priority queue of tag 110.	3h
11:10	802.1p Priority Tag 101	R/W	These two bits are used to assign priority queue of tag 101.	2h
9:8	802.1p Priority Tag 100	R/W	These two bits are used to assign priority queue of tag 100.	2h
7:6	802.1p Priority Tag 011	R/W	These two bits are used to assign priority queue of tag 011.	1h
5:4	802.1p Priority Tag 010	R/W	These two bits are used to assign priority queue of tag 010.	1h

**Table 274: Priority Threshold Register (Page 30h: Address 30h–31h)**

Bit	Name	R/W	Description	Default
3:2	802.1p Priority Tag 001	R/W	These two bits are used to assign priority queue of tag 001.	0h
1:0	802.1p Priority Tag 000	R/W	These two bits are used to assign priority queue of tag 000.	0h

## DiffServ DSCP Priority Register (Page 30h/Addr 40h–4Fh)

Register 40h to register 4Fh are used to assign priority to different Differentiated Service. To provides 4 priority queues and 64 different traffic classes, a 64x2 table is needed. Each entry represents one traffic class. Two bits in an entry represents the priority of that traffic.

Table 275 and Table 276 define four entries: the remaining 60 traffic classes have the same format (they are not represented in this document).

**Table 275: DiffServ DSCP Priority Register 1 (Page 30h: Address 40h–47h)**

Bit	Name	R/W	Description	Default
63:62	Priority of DSCP=011111	R/W	See detail description above.	0
.....	.....	R/W		
7:6	Priority of DSCP=000011	R/W	See detail description above.	0
5:4	Priority of DSCP=000010	R/W	See detail description above.	0
3:2	Priority of DSCP=000001	R/W	See detail description above.	0
1:0	Priority of DSCP=000000	R/W	See detail description above.	0

**Table 276: DiffServ DSCP Priority Register 2 (Page 30h: Address 48h–4Fh)**

Bit	Name	R/W	Description	Default
63:62	Priority of DSCP=111111	R/W	See detail description above.	0
.....	.....	R/W		
7:6	Priority of DSCP=100011	R/W	See detail description above.	0
5:4	Priority of DSCP=100010	R/W	See detail description above.	0
3:2	Priority of DSCP=100001	R/W	See detail description above.	0
1:0	Priority of DSCP=100000	R/W	See detail description above.	0

## QoS Reason Code Enable Register (Page 30h/Addr 58h–59h)

**Table 277: QoS Reason Code Enable Register (Page 30h: Address 58h–59h)**

Bit	Name	R/W	Description	Default
15:12	RSVD	–	Reserved	0

**Table 277: QoS Reason Code Enable Register (Page 30h: Address 58h–59h)**

<b>Bit</b>	<b>Name</b>	<b>R/W</b>	<b>Description</b>	<b>Default</b>
11:10	PRI_EXCEPT	R/W	To assign priority queue of Reason Code = EXCEPTION / FLOODING packets	01
9:8	PRI_PROTOCOL_SNOOP	R/W	To assign priority queue of Reason Code = PROTOCOL SNOOPING packets	10
7:6	PRI_PROTOCOL_TERM	R/W	To assign priority queue of Reason Code = PROTOCOL TERMINATION packets	11
5:4	PRI_SWITCH	R/W	To assign priority queue of Reason Code = SWITCH packets	10
3:2	PRI_SA_LEARN	R/W	To assign priority queue of Reason Code = SA LEARNING packets	0
1:0	PRI_MIRROR	R/W	To assign priority queue of Reason Code = MIRROR packets	0

## Page 31h: MAC-Based Aggregation Registers

**Table 278: MAC-Based Aggregation Registers (Page 31h)**

<b>Addr</b>	<b>Bits</b>	<b>Description</b>
00h	8	"Global Aggregation Control Register (Page 31h/Addr 00h)" on page 296
01h–0Fh	Reserved	
10h–17h	64	Group n=1, "Aggregation Control Group n Register (Page 31h/Addr 10h–7Fh)" on page 297
18h–1Fh	64	Group n=2, "Aggregation Control Group n Register (Page 31h/Addr 10h–7Fh)" on page 297
20h–27h	64	Group n=3, "Aggregation Control Group n Register (Page 31h/Addr 10h–7Fh)" on page 297
28h–2Fh	64	Group n=4, "Aggregation Control Group n Register (Page 31h/Addr 10h–7Fh)" on page 297
30h–37h	64	Group n=5, "Aggregation Control Group n Register (Page 31h/Addr 10h–7Fh)" on page 297
38h–3Fh	64	Group n=6, "Aggregation Control Group n Register (Page 31h/Addr 10h–7Fh)" on page 297
40h–47h	64	Group n=7, "Aggregation Control Group n Register (Page 31h/Addr 10h–7Fh)" on page 297
48h–4Fh	64	Group n=8, "Aggregation Control Group n Register (Page 31h/Addr 10h–7Fh)" on page 297
50h–57h	64	Group n=9, "Aggregation Control Group n Register (Page 31h/Addr 10h–7Fh)" on page 297
58h–5Fh	64	Group n=10, "Aggregation Control Group n Register (Page 31h/Addr 10h–7Fh)" on page 297
60h–67h	64	Group n=11, "Aggregation Control Group n Register (Page 31h/Addr 10h–7Fh)" on page 297
68h–6Fh	64	Group n=12, "Aggregation Control Group n Register (Page 31h/Addr 10h–7Fh)" on page 297
70h–77h	64	Group n=13, "Aggregation Control Group n Register (Page 31h/Addr 10h–7Fh)" on page 297
78h–7Fh	64	Group n=14, "Aggregation Control Group n Register (Page 31h/Addr 10h–7Fh)" on page 297
80h–EFh	Reserved	
F0h–F7h	64	SPI Data I/O[0:7]
F8h–FDh	Reserved	
FEh	8	SPI Status
FFh	8	Page Register

## Global Aggregation Control Register (Page 31h/Addr 00h)

*Table 279: Global Aggregation Control Register (Page 31h, Address 00h)*

<i>Bit</i>	<i>Name</i>	<i>R/W</i>	<i>Description</i>	<i>Default</i>
7:4	TRKG_SEED	R/W	Aggregation hash index selection. <ul style="list-style-type: none"> <li>• bit 7: IPv4_SIP</li> <li>• bit 6: IPv4_DIP</li> <li>• bit 5: MAC_SA</li> <li>• bit 4: MAC_DA</li> </ul>	0x03
3:2	RSVD	RO	Reserved. Write default. Ignore on read.	0
1	EN_AGGR	R/W	Enable Aggregation. <ul style="list-style-type: none"> <li>• 1: Enable.</li> <li>• 0: Disable.</li> </ul>	0
0	RSVD	RO	Reserved. Write default. Ignore on read.	0



## Aggregation Control Group n Register (Page 31h/Addr 10h–7Fh)

**Table 280: Aggregation Control Group n Register**

<b>Bit</b>	<b>Name</b>	<b>R/W</b>	<b>Description</b>	<b>Default</b>
63:54	RSVD	RO	Reserved Write default. Ignore on read.	0
53	En_TRNK_GRP	R/W	Enable Aggregation Group n. Set this bit and TRNK_PORT_MAP to enable Aggregation Group Vector.	0
52:51	RSVD	–	Reserved	0
50:24	TRNK_PORT_MAP	R/W	Aggregation Group n Vector. A bit mask corresponding to the physical ports on the chip. For physical ports which belong to the same aggregation, the corresponding bit should be set to 1. <ul style="list-style-type: none"> <li>• Bit 50 = GigaPort G1</li> <li>• Bit 49 = GigaPort G0</li> <li>• Bit 48 = IMP port</li> <li>• Bits 47:24 = 10/100 ports [port 23–port 0]</li> </ul> <p><b>Note:</b></p> <ul style="list-style-type: none"> <li>– Each port can belong to only one aggregation group.</li> <li>– Up to 8 ports can be assigned to an aggregation group.</li> <li>– All ports in an aggregation group must be from the same speed.</li> <li>– When En_TRNK_GRP is not set, no bits can be set in the TRNK_PORT_MAP.</li> </ul>	0
23:0	RSVD	–	Reserved	0

## Page 33h: Port Egress Control Registers

**Table 281: Port Egress Control Registers (Page 33h)**

<b>Address</b>	<b>Bits</b>	<b>Description</b>
00h–07h	64	Port 0 “Port Egress Control Register (Page 33h/Addr 00h–D7h)” on page 299
08h–0Fh	64	Port 1 “Port Egress Control Register (Page 33h/Addr 00h–D7h)” on page 299
10h–17h	64	Port 2 “Port Egress Control Register (Page 33h/Addr 00h–D7h)” on page 299
18h–1Fh	64	Port 3 “Port Egress Control Register (Page 33h/Addr 00h–D7h)” on page 299
20h–27h	64	Port 4 “Port Egress Control Register (Page 33h/Addr 00h–D7h)” on page 299
28h–2Fh	64	Port 5 “Port Egress Control Register (Page 33h/Addr 00h–D7h)” on page 299
30h–37h	64	Port 6 “Port Egress Control Register (Page 33h/Addr 00h–D7h)” on page 299
38h–3Fh	64	Port 7 “Port Egress Control Register (Page 33h/Addr 00h–D7h)” on page 299
40h–47h	64	Port 8 “Port Egress Control Register (Page 33h/Addr 00h–D7h)” on page 299
48h–4Fh	64	Port 9 “Port Egress Control Register (Page 33h/Addr 00h–D7h)” on page 299
50h–57h	64	Port 10 “Port Egress Control Register (Page 33h/Addr 00h–D7h)” on page 299
58h–5Fh	64	Port 11 “Port Egress Control Register (Page 33h/Addr 00h–D7h)” on page 299
60h–67h	64	Port 12 “Port Egress Control Register (Page 33h/Addr 00h–D7h)” on page 299
68h–6Fh	64	Port 13 “Port Egress Control Register (Page 33h/Addr 00h–D7h)” on page 299
70h–77h	64	Port 14 “Port Egress Control Register (Page 33h/Addr 00h–D7h)” on page 299
78h–7Fh	64	Port 15 “Port Egress Control Register (Page 33h/Addr 00h–D7h)” on page 299
80h–87h	64	Port 16 “Port Egress Control Register (Page 33h/Addr 00h–D7h)” on page 299
88h–8Fh	64	Port 17 “Port Egress Control Register (Page 33h/Addr 00h–D7h)” on page 299
90h–97h	64	Port 18 “Port Egress Control Register (Page 33h/Addr 00h–D7h)” on page 299
98h–9Fh	64	Port 19 “Port Egress Control Register (Page 33h/Addr 00h–D7h)” on page 299

**Table 281: Port Egress Control Registers (Cont.)(Page 33h)**

Address	Bits	Description
A0h–A7h	64	Port 20 “Port Egress Control Register (Page 33h/Addr 00h–D7h)” on page 299
A8h–AFh	64	Port 21 “Port Egress Control Register (Page 33h/Addr 00h–D7h)” on page 299
B0h–B7h	64	Port 22 “Port Egress Control Register (Page 33h/Addr 00h–D7h)” on page 299
B8h–BFh	64	Port 23 “Port Egress Control Register (Page 33h/Addr 00h–D7h)” on page 299
C0h–C7h	64	IMP Port “Port Egress Control Register (Page 33h/Addr 00h–D7h)” on page 299
C8h–CFh	64	Gigabit Port 0 “Port Egress Control Register (Page 33h/Addr 00h–D7h)” on page 299
D0h–D7h	64	Gigabit Port 1 “Port Egress Control Register (Page 33h/Addr 00h–D7h)” on page 299
D8h–EFh	Reserved	
F0h–F7h	64	SPI Data I/O[0:7]
F8h–FDh	Reserved	
FEh	8	SPI Status
FFh	8	Page Register

## Port Egress Control Register (Page 33h/Addr 00h–D7h)

**Table 282: Port Egress Control Register (Pages: 33h, Address 00h–D7h)**

Bit	Name	R/W	Description	Default
63:51	RSVD	RO	Reserved. Write default. Ignore on read.	0
50:24	PORT_EGRESS_En[50:24]	R/W	Port Egress Enable vector. A bit mask corresponding to the physical ports on the chip. Set corresponding bit to 1 to enable port egress forwarding. Set bit to 0 inhibits the port egress forwarding. <ul style="list-style-type: none"> <li>• Bit 50 = GigaPort G1</li> <li>• Bit 49 = GigaPort G0</li> <li>• Bit 48 = IMP</li> <li>• Bits 47:24 = 10/100 ports [port 23–port 0]</li> </ul>	7-FFFF-FF
23:0	RSVD	–	Reserved	–

## Page 34h: 802.1Q VLAN Registers

**Table 283: 802.1Q VLAN Registers (Page 34h)**

<b>Address</b>	<b>Bits</b>	<b>Description</b>
00h	8	"802.1Q Control 0 Register (Page 34h/Addr 00h)" on page 301
01h	8	"802.1Q Control 1 Register (Page 34h/Addr 01h)" on page 301
02h	8	"802.1Q Control 2 Register (Page 34h/Addr 02h)" on page 304
03h	8	"802.1Q Control 4 Register (Page 34h/Addr 03h)" on page 306
04h	8	"802.1Q Control 5 Register (Page 34h/Addr 04h)" on page 307
05h-07h	Reserved	–
08h-0Fh	64	"802.1Q Control 3 Register (Page 34h/Addr 08h-0Fh)" on page 305
10h-3Fh	Reserved	
40h-75h	16	"802.1Q Default Port Tag Register (Page 34h/Addr 40h-75h)" on page 308
76h-8Fh	Reserved	–
90h	8	"Global Double Tagging Control Register (Page 34h/Addr 90h)" on page 309
91h-97h	Reserved	
98h-9Fh	64	"SP Portmap Selection Register (Page 34h/Addr 98h-9Fh)" on page 311
A0h-A7h	64	"VLAN to VLAN Control Register (Page 34h/Addr A0h-A7h)" on page 312
A8h-AFh	64	"MAC to VLAN Control Register (Page 34h/Addr A8h-AFh)" on page 313
B0h-B7h	64	"Protocol to VLAN Control Register (Page 34h/Addr B0h-B7h)" on page 314
B8h-BFh	64	"Trusted Customer VLAN Register (Page 34h: Address B8h-BFh)" on page 315
F0h-F7h	64	SPI Data I/O[0:7]
F8h-FDh	Reserved	
FEh	8	SPI Status
FFh	8	Page Register

## 802.1Q Control 0 Register (Page 34h/Addr 00h)

**Table 284: 802.1Q Control 0 Register (Pages: 34h, Address 00h)**

Bit	Name	R/W	Description	Default
7	EN_1QVLAN	R/W	Enable 802.1Q VLAN. When set to 1, enable 802.1Q VLAN function.	0
6:5	VID_MAC Control	R/W	ARL Table Hashing Control. When 802.1Q VLAN is enabled, these bits determine the ARL Table hashing scheme. <ul style="list-style-type: none"> <li>• 11: Use both [VID, MAC].</li> <li>• 10: Reserved.</li> <li>• 01: Reserved.</li> <li>• 00: Use only [MAC].</li> </ul>	11
4	EN_DROP_VID_MISS	R/W	Enable Drop VID Miss Frames When asserted, any incoming frames with a matching DA, but not VLAN ID, are dropped.	0
3:0	RSVD	–	Reserved	0x2

## 802.1Q Control 1 Register (Page 34h/Addr 01h)

**Table 285: 802.1Q Control 1 Register (Pages: 34h, Address 01h)**

Bit	Name	R/W	Description	Default
7	Reserved	RO	Reserved	0
6	IPMC_UntagMap_Chk	R/W	Bypass IP MultiCast VLAN Untag_Map Check. <ul style="list-style-type: none"> <li>• 1: Enables checking IPMC frame against VLAN Untag_Map.</li> <li>• 0: When asserted disables checking IPMC frame against VLAN Untag_Map.</li> </ul>	0
5	IPMC_FwdMap_Chk	R/W	Bypass IP MultiCast VLAN Fwd_Map Check. <ul style="list-style-type: none"> <li>• 1: Enables checking IPMC frame against VLAN Fwd_Map.</li> <li>• 0: When asserted disables checking IPMC frame against VLAN Fwd_Map.</li> </ul>	0
4	RSVD	RO	Reserved Write default. Ignore on read.	0

**Table 285: 802.1Q Control 1 Register (Pages: 34h, Address 01h) (Cont.)**

<b>Bit</b>	<b>Name</b>	<b>R/W</b>	<b>Description</b>	<b>Default</b>
3	Rsvd MC_UntagMap_Chk	R/W	Reserved MultiCast (except GMRP and GVRP) VLAN Untag_Map Check. <ul style="list-style-type: none"> <li>• 1: When asserted enables checking reserved MC frame against VLAN Untag_Map. <ul style="list-style-type: none"> <li>– For untagged incoming packets, check against VLAN Untag_Map from the port default tag.</li> </ul> </li> <li>• 0: Disables checking reserved MC frame against VLAN Untag_Map. <ul style="list-style-type: none"> <li>– When incoming packet is untagged, port default tag is stripped on egress.</li> <li>– A tagged incoming packet is tagged on egress.</li> </ul> </li> </ul>	0
2	Rsvd MC_FwdMap_Chk	R/W	Reserved MultiCast (except GMRP and GVRP) VLAN Fwd_Map Check. <ul style="list-style-type: none"> <li>• 1: When asserted enables checking reserved MC frame against VLAN Fwd_Map. <ul style="list-style-type: none"> <li>– For untagged incoming packets, check against VLAN Fwd_Map from the port default tag.</li> </ul> </li> <li>• 0: Disables checking reserved MC frame against VLAN Fwd_Map. <ul style="list-style-type: none"> <li>– For untagged incoming packets, use VLAN Fwd_Map from the port default tag.</li> </ul> </li> </ul>	0
1	Special Entry MC_UntagMap_Chk	R/W	Special Entry MAC Untag Map Check. When an ingress MAC DA matches what is defined in either Multiport Address 1 or Multiport Address 2 register, the frame bypasses ARL checking. The forwarding vector for this frame is determined by either Multi Vector 1 or Multi Vector 2 register respectively. <ul style="list-style-type: none"> <li>• 1: When asserted enables checking reserved MC frame against VLAN Untag_Map. <ul style="list-style-type: none"> <li>– For untagged incoming packets, check against VLAN Untag_Map from the port default tag.</li> </ul> </li> <li>• 0: Disables checking reserved MC frame against VLAN Untag_Map. <ul style="list-style-type: none"> <li>– When incoming packet is untagged, port default tag is stripped on egress.</li> <li>– A tagged incoming packet is tagged on egress.</li> </ul> </li> </ul>	0

**Table 285: 802.1Q Control 1 Register (Pages: 34h, Address 01h) (Cont.)**

<b>Bit</b>	<b>Name</b>	<b>R/W</b>	<b>Description</b>	<b>Default</b>
0	Special Entry MC_FwdMap_Chk	R/W	<p>Special Entry MAC Forward Map Check.</p> <p>When an ingress MAC DA matches what is defined in either Multiport Address 1 or Multiport Address 2 register, the frame bypasses ARL checking. The forwarding vector for this frame is determined by either Multi Vector 1 or Multi Vector 2 register respectively.</p> <ul style="list-style-type: none"> <li>• 1: When asserted enables checking reserved MC frame against VLAN Fwd_Map. <ul style="list-style-type: none"> <li>– For untagged incoming packets, check against VLAN Fwd_Map from the port default tag.</li> </ul> </li> <li>• 0: Disables checking reserved MC frame against VLAN Fwd_Map. <ul style="list-style-type: none"> <li>– For untagged incoming packets, use VLAN Fwd_Map from the port default tag.</li> </ul> </li> </ul>	0

## 802.1Q Control 2 Register (Page 34h/Addr 02h)

Table 286: 802.1Q Control 2 Register (Pages: 34h, Address 02h)

Bit	Name	R/W	Description	Default
7	RSVD	R/W	Reserved Write as default. Ignore on read.	0
6	GMRP/GVRP UntagMap_Chk	R/W	GMRP or GVRP Untag_Map Check <ul style="list-style-type: none"> <li>1: When asserted enables checking GMRP and GVRP frame against Untag_Map.</li> <li>0: Disables checking GMRP and GVRP frame against Untag_Map.</li> </ul> <b>Note:</b> This feature does not apply to IMP configured as a management port.	0
5	GMRP/ GVRP_FwdMap_Chk	R/W	GMRP or GVRP VLAN Fwd_Map Check <ul style="list-style-type: none"> <li>1: When asserted enables checking GMRP or GVRP frame against VLAN Fwd_Map.</li> <li>0: Disables checking GMRP or GVRP frame against VLAN Fwd_Map.</li> </ul> <b>Note:</b> This feature does not apply to IMP configured as a management port.	0
4	RSVD	R/W	Reserved Write as default. Ignore on read.	0
3	IMP Mngt Frm_UntagMap_Chk	R/W	IMP Management Frame Untag_Map Check. This bit apply to IMP Port when it is configured as Management port. <ul style="list-style-type: none"> <li>1: When asserted disables checking frames received at IMP management port against Untag_Map.</li> <li>0: Enables checking frames received at IMP management port against Untag_Map.</li> </ul>	0
2	IMP Mngt Frm_FwdMap_Chk	R/W	MII Management Frame VLAN Fwd_Map Check <ul style="list-style-type: none"> <li>1: When asserted disables checking frames received at IMP management port against VLAN Fwd_Map.</li> <li>0: Enables checking frame received at IMP management port against VLAN Fwd_Map.</li> </ul> <b>Note:</b> An untagged frame received by the IMP management port is never tagged.	0
1:0	RSVD	RO	Reserved. Write as default. Ignore on read.	0



## 802.1Q Control 3 Register (Page 34h/Addr 08h–0Fh)



**Note:** The offset address for this register is out of sequence.

**Table 287: 802.1Q Control 3 Register (Pages: 34h, Address 08h–0Fh)**

Bit	Name	R/W	Description	Default
63	VID_FFF	R/W	VID Special Handling Any frame with VID = FFF is treated 1 = As normal frame. 0 = As VID violation frame. (Default)	0
62:51	RSVD	RO	Reserved. Write default. Ignore on read.	0
50:24	Enable Drop Non 1Q Frame	R/W	Enable Drop Non 1Q Frames. A 27-bit mask corresponds to the physical ports on the chip. Setting any bit to 1 enables non_1Q (untagged or priority tagged) ingress frame to be dropped by the corresponding port. <ul style="list-style-type: none"> <li>• Bit 50 = GigaPort G1</li> <li>• Bit 49 = GigaPort G0</li> <li>• Bit 48 = IMP.</li> <li>• Bits 47:24 = 10/100 ports [port 23–port 0]</li> </ul>	0
23:0	RSVD	–	Reserved	0

## 802.1Q Control 4 Register (Page 34h/Addr 03h)

**Table 288: 802.1Q Control 4 Register (Pages: 34h, Address 03h)**

Bit	Name	R/W	Description	Default																		
7:6	Ingress_VID_check	R/W	<p>Perform ingress VLAN source port membership check. Ingress VID violation is detected when the source port is not found in the VLAN Fwd_Map that is referred to by the ingress VID.</p> <ul style="list-style-type: none"> <li>00: Forward ingress VID violation frame but do not learn SA into ARL table.</li> <li>01: Drop frame if ingress VID violation is detected.</li> <li>10: Bypass checking for ingress VID violation but SA is learned into ARL table.</li> </ul> <p><b>Note:</b> Ingress_VID_check does not apply to the IMP configured as management port.</p>	10																		
5	Mngt_Rcv_GVRP	R/W	<p>Forward GVRP frame to management port</p> <p>When set this bit to 1, forward GVRP frames to management port.</p>	0																		
4	Mngt_Rcv_GMRP	R/W	<p>Forward GMRP frame to management port</p> <p>When set this bit to 1, forward GMRP frames to management port.</p>	0																		
3:2	RSVD	RO	<p>Reserved.</p> <p>Write default. Ignore on read.</p>	0																		
1	VLAN_VLAN_OPT	R/W	<p>VLAN to VLAN Table Optional Control (Revision B Silicon only). This bit selects the index used to search the VLAN to VLAN table.</p> <p><b>Note:</b> PORTID is referred to as the physical port ID. The logical port ID starts from 0, 1, 2, ... The physical port ID starts from 24, 25, 26..... The logical to physical port ID mapping is as follows:</p> <table border="1" style="margin-left: 40px;"> <thead> <tr> <th>Logical Port ID</th> <th>PORTID</th> </tr> </thead> <tbody> <tr><td>0</td><td>24</td></tr> <tr><td>1</td><td>25</td></tr> <tr><td>2</td><td>26</td></tr> <tr><td>...</td><td>...</td></tr> <tr><td>23</td><td>47</td></tr> <tr><td>IMP</td><td>48</td></tr> <tr><td>GigaPort G0</td><td>49</td></tr> <tr><td>GigaPort G1</td><td>50</td></tr> </tbody> </table> <ul style="list-style-type: none"> <li>0 = Select VID[11:0] as the index</li> <li>1 = Select {(PORTID-24)[4:0], VID[6:0]} as the index</li> </ul>	Logical Port ID	PORTID	0	24	1	25	2	26	...	...	23	47	IMP	48	GigaPort G0	49	GigaPort G1	50	0
Logical Port ID	PORTID																					
0	24																					
1	25																					
2	26																					
...	...																					
23	47																					
IMP	48																					
GigaPort G0	49																					
GigaPort G1	50																					
0	RSVD	RO	<p>Reserved.</p> <p>Write default. Ignore on read.</p>	0																		

## 802.1Q Control 5 Register (Page 34h/Addr 04h)

Table 289: 802.1Q Control 5 Register (Pages: 34h, Address 04h)

Bit	Name	R/W	Description	Default
7	RSVD	–	Reserved	0
6	Preserve_non_1Q	R/W	Egress non_1Q frame control. <ul style="list-style-type: none"> <li>1 = Preserve ingress non_1Q frames.</li> <li>0 = Apply VLAN rules if enabled to ingress non_1Q frames.</li> </ul>	0
5	Dis_Egress_Dir_Bypass_Trunking	R/W	Disable Egress Direct Frame Trunking Rule Check. <ul style="list-style-type: none"> <li>1 = Egress direct frames from the host management system do not bypass trunking rule check.</li> <li>0 = Allow egress direct frames from the host management system to bypass.</li> </ul>	0
4	RSVD	RO	Reserved. Write as default. Ignore on read.	1
3	drop_Vtable_miss	R/W	Ingress VID is pointing to a nonvalid entry in the VLAN table. When set to: <ul style="list-style-type: none"> <li>1, a frame with VLAN table miss is dropped.</li> <li>0, a frame with VLAN table miss is trapped to IMP.</li> </ul>	0
2	RSVD	RO	Reserved. Write default. Ignore on read.	0
1	Bypass_Mngt_Rx_CRC_Chk	R/W	Bypass CRC Check at Management port. <ul style="list-style-type: none"> <li>1 = The management port with CPU on it ignores any CRC from BRCM tagged frame or Ethernet frame.</li> <li>0 = The management port checks both CRCs.</li> </ul> <p><b>Note:</b> With this option, CPU does not need to calculate CRC for BRCM tagged frame. However it is still required to include a place holder for the BRCM tag CRC.</p>	0
0	RSVD	R/W	Write default. Ignore on read.	0

**Note:** For normal operation, Broadcom recommends to set bits 3, 1, and 0 of this register to 1.

## 802.1Q Default Port Tag Register (Page 34h/Addr 40h–75h)

See [Table 291: “Default 802.1Q Tag,” on page 309.](#)

**Table 290: 802.1Q Default Port Tag Register (Page: 34h, Address 40h–75h)**

<b>Bit</b>	<b>Name</b>	<b>R/W</b>	<b>Description</b>	<b>Default</b>
Addr 40h–41h bit [15:0]	Default Tag Port 0	R/W	Default 802.1Q tag assigned to port 0.	0018h
Addr 42h–43h bit [15:0]	Default Tag Port 1	R/W	Default 802.1Q tag assigned to port 1.	0019h
Addr 44h–45h bit [15:0]	Default Tag Port 2	R/W	Default 802.1Q tag assigned to port 2.	001Ah
Addr 46h–47h bit [15:0]	Default Tag Port 3	R/W	Default 802.1Q tag assigned to port 3.	001Bh
Addr 48h–49h bit [15:0]	Default Tag Port 4	R/W	Default 802.1Q tag assigned to port 4.	001Ch
Addr 4Ah–4Bh bit [15:0]	Default Tag Port 5	R/W	Default 802.1Q tag assigned to port 5.	001Dh
Addr 4Ch–4Dh bit [15:0]	Default Tag Port 6	R/W	Default 802.1Q tag assigned to port 6.	001Eh
Addr 4Eh–4Fh bit [15:0]	Default Tag Port 7	R/W	Default 802.1Q tag assigned to port 7.	001Fh
Addr 50h–51h bit [15:0]	Default Tag Port 8	R/W	Default 802.1Q tag assigned to port 8.	0020h
Addr 52h–53h bit [15:0]	Default Tag Port 9	R/W	Default 802.1Q tag assigned to port 9.	0021h
Addr 54h–55h bit [15:0]	Default Tag Port 10	R/W	Default 802.1Q tag assigned to port 10.	0022h
Addr 56h–57h bit [15:0]	Default Tag Port 11	R/W	Default 802.1Q tag assigned to port 11.	0023h
Addr 58h–59h bit [15:0]	Default Tag Port 12	R/W	Default 802.1Q tag assigned to port 12.	0024h
Addr 5Ah–5Bh bit [15:0]	Default Tag Port 13	R/W	Default 802.1Q tag assigned to port 13.	0025h
Addr 5Ch–5Dh bit [15:0]	Default Tag Port 14	R/W	Default 802.1Q tag assigned to port 14.	0026h
Addr 5Eh–5Fh bit [15:0]	Default Tag Port 15	R/W	Default 802.1Q tag assigned to port 15.	0027h
Addr 60h–61h bit [15:0]	Default Tag Port 16	R/W	Default 802.1Q tag assigned to port 16.	0028h
Addr 62h–63h bit [15:0]	Default Tag Port 17	R/W	Default 802.1Q tag assigned to port 17.	0029h
Addr 64h–65h bit [15:0]	Default Tag Port 18	R/W	Default 802.1Q tag assigned to port 18.	002Ah
Addr 66h–67h bit [15:0]	Default Tag Port 19	R/W	Default 802.1Q tag assigned to port 19.	002Bh

**Table 290: 802.1Q Default Port Tag Register (Page: 34h, Address 40h–75h) (Cont.)**

<b>Bit</b>	<b>Name</b>	<b>R/W</b>	<b>Description</b>	<b>Default</b>
Addr 68h–69h bit [15:0]	Default Tag Port 20	R/W	Default 802.1Q tag assigned to port 20.	002Ch
Addr 6Ah–6Bh bit [15:0]	Default Tag Port 21	R/W	Default 802.1Q tag assigned to port 21.	002Dh
Addr 6Ch–6Dh bit [15:0]	Default Tag Port 22	R/W	Default 802.1Q tag assigned to port 22.	002Eh
Addr 6Eh–6Fh bit [15:0]	Default Tag Port 23	R/W	Default 802.1Q tag assigned to port 23.	002Fh
Addr 70h–71h bit [15:0]	Default tag IMP Port	R/W	Default 802.1Q tag assigned to IMP port.	0030h
Addr 72h–73h bit [15:0]	Default Tag G0 Port	R/W	Default 802.1Q tag assigned to Gigabit port G0.	0031h
Addr 74h–75h bit [15:0]	Default Tag G1 Port	R/W	Default 802.1Q tag assigned to Gigabit port G1.	0032h

**Table 291: Default 802.1Q Tag**

<b>Bit</b>	<b>Name</b>	<b>R/W</b>	<b>Description</b>	<b>Default</b>
15:13	Pri	R/W	802.1p Priority bits.	0h
12	CFI	RO	Reserved. Write default. Ignore on read.	0
11:0	Default VID	R/W	Default 802.1Q VID for port n. <ul style="list-style-type: none"> <li>• n = 50: GigaPort G1</li> <li>• n = 49: GigaPort G0</li> <li>• n = 48: IMP</li> <li>• n = 47–24: 10/100 ports (23:0) respectively.</li> </ul>	n

## Global Double Tagging Control Register (Page 34h/Addr 90h)

**Table 292: Global Double Tagging Control Register (Pages: 34h, Address 90h)**

<b>Bit</b>	<b>Name</b>	<b>R/W</b>	<b>Description</b>	<b>Default</b>
7:2	RSVD	RO	Reserved Write default. Ignore on read.	0
1	EN_DBL_ISP_TAG	R/W	Enable Double ISP Tag.	0

**Table 292: Global Double Tagging Control Register (Pages: 34h, Address 90h)**

<b>Bit</b>	<b>Name</b>	<b>R/W</b>	<b>Description</b>	<b>Default</b>
0	Rsvd_MC_Flood	R/W	Enable Reserved Multicast Flood Mode. When BCM53242M is configured as management mode and double tagging is enabled: <ul style="list-style-type: none"><li>• 1 = Reserved multicast frame is flooded per VLAN rules.</li><li>• 0 = Reserved multicast frames is trapped to IMP management port.</li></ul> <b>Note:</b> Reserved multicast frames exclude pause frame. Pause frame is treated as MAC Control Frame.	0

Broadcom Confidential

## SP Portmap Selection Register (Page 34h/Addr 98h–9Fh)

**Table 293: SP Portmap Selection Register (Pages: 34h, Address 98h–9Fh)**

<b>Bit</b>	<b>Name</b>	<b>R/W</b>	<b>Description</b>	<b>Default</b>
63:51	RSVD	RO	Reserved Write default. Ignore on read.	0
50:24	SP_PORTMAP	R/W	Enable Service Provider (SP) Port Map A 27-bit mask which selectively allows any port with its corresponding bit set, to enable as the ISP port. <ul style="list-style-type: none"> <li>• Bit 50 = GigaPort G1</li> <li>• Bit 49 = GigaPort G0</li> <li>• Bit 48 = IMP</li> <li>• Bits 47:24 = 10/100 ports [port 23–port 0]</li> </ul>	0
23:0	RSVD	–	Reserved	0

## VLAN to VLAN Control Register (Page 34h/Addr A0h–A7h)

**Table 294: VLAN To VLAN Control Register (Pages: 34h, Address A0h–A7h)**

<b>Bit</b>	<b>Name</b>	<b>R/W</b>	<b>Description</b>	<b>Default</b>
63:51	RSVD	RO	Reserved. Write default. Ignore on read.	0
50:24	VLAN_VLAN_PORTMAP	R/W	Enable VLAN to VLAN table look up A 27-bit mask which selectively allows any port with its corresponding bit set, to enable VLAN translation. <ul style="list-style-type: none"> <li>• Bit 50 = GigaPort G1</li> <li>• Bit 49 = GigaPort G0</li> <li>• Bit 48 = IMP</li> <li>• Bits 47:24 = 10/100 ports [port 23–port 0]</li> </ul>	0
23:0	RSVD	–	Reserved	0



## MAC to VLAN Control Register (Page 34h/Addr A8h–AFh)

**Table 295: MAC To VLAN Control Register (Pages: 34h, Address A8h–AFh)**

<b>Bit</b>	<b>Name</b>	<b>R/W</b>	<b>Description</b>	<b>Default</b>
63:51	RSVD	RO	Reserved Write default. Ignore on read.	0
50:24	MAC_VLAN_PORTMAP	R/W	Enable MAC to VLAN table look up A 27-bit mask which selectively allows any port with its corresponding bit set, to enable MAC-based VLAN. <ul style="list-style-type: none"> <li>• Bit 50 = GigaPort G1</li> <li>• Bit 49 = GigaPort G0</li> <li>• Bit 48 = IMP</li> <li>• Bits 47:24 = 10/100 ports [port 23–port 0]</li> </ul>	0
23:0	RSVD	–	Reserved	0

## Protocol to VLAN Control Register (Page 34h/Addr B0h–B7h)

**Table 296: Protocol To VLAN Control Register (Pages: 34h, Address B0h–B7h)**

<b>Bit</b>	<b>Name</b>	<b>R/W</b>	<b>Description</b>	<b>Default</b>
63:51	RSVD	RO	Reserved Write default. Ignore on read.	0
50:24	PROT_VLAN_PORTMAP	R/W	Enable Protocol to VLAN table look up A 27-bit mask which selectively allows any port with its corresponding bit set, to enable Protocol-based VLAN. <ul style="list-style-type: none"> <li>• Bit 50 = GigaPort G1</li> <li>• Bit 49 = GigaPort G0</li> <li>• Bit 48 = IMP</li> <li>• Bits 47:24 = 10/100 ports [port 23–port 0]</li> </ul>	0
23:0	RSVD	–	Reserved	0

## Trusted Customer VLAN Register (Page 34h: Address B8h–BFh)

*Table 297: Trusted Customer VLAN Register (Page 34h: Address B8h–BFh)*

<i>Bit</i>	<i>Name</i>	<i>R/W</i>	<i>Description</i>	<i>Default</i>
63:51	RSVD	–	Reserved	0
50:24	TRUSTED_CVLAN_PORTMAP	R/W	<p>Enable Trusted Customer VLAN table look up when the corresponding bit is set, port to use the trusted VID of the incoming 802.1Q tag.</p> <ul style="list-style-type: none"> <li>• Bit 50 = GigaPort G1</li> <li>• Bit 49 = GigaPort G0</li> <li>• Bit 48 = IMP</li> <li>• Bits 47:24 = 10/100 ports [port 23–port 0]</li> </ul>	7-FFFF-FF
23:0	RSVD	–	Reserved	0

## Page 40h: 802.1x Registers

*Table 298: 802.1x Registers (Page 40h)*

<i>Addr</i>	<i>Bits</i>	<i>Description</i>
00h–1Fh	8	<a href="#">“Port EAP Configuration Register (Page 40h/Addr 00h–1Ah)” on page 317</a>
20h–CFh	48	<a href="#">“Port EAP Destination Address Register (Page 40h/Addr 20h–BCh)” on page 320</a>
E0h–EFh	Reserved	
F0h–F7h	64	SPI Data I/O[0:7]
F8h–FDh	Reserved	
FEh	8	SPI Status
FFh	8	Page Register

## Port EAP Configuration Register (Page 40h/Addr 00h–1Ah)

See [Table 300: “EAP Configuration Register,”](#) on page 318.

**Table 299: Port EAP Configuration Register (Page: 40h, Address 00h–1Ah)**

<b>Bit</b>	<b>Name</b>	<b>R/W</b>	<b>Description</b>	<b>Default</b>
Addr 00h bit [7:0]	Port 0's	R/W	EAP Configuration	0
Addr 01h bit [7:0]	Port 1's	R/W	EAP Configuration	0
Addr 02h bit [7:0]	Port 2's	R/W	EAP Configuration	0
Addr 03h bit [7:0]	Port 3's	R/W	EAP Configuration	0
Addr 04h bit [7:0]	Port 4's	R/W	EAP Configuration	0
Addr 05h bit [7:0]	Port 5's	R/W	EAP Configuration	0
Addr 06h bit [7:0]	Port 6's	R/W	EAP Configuration	0
Addr 07h bit [7:0]	Port 7's	R/W	EAP Configuration	0
Addr 08h bit [7:0]	Port 8's	R/W	EAP Configuration	0
Addr 09h bit [7:0]	Port 9's	R/W	EAP Configuration	0
Addr 0Ah bit [7:0]	Port 10's	R/W	EAP Configuration	0
Addr 0Bh bit [7:0]	Port 11's	R/W	EAP Configuration	0
Addr 0Ch bit [7:0]	Port 12's	R/W	EAP Configuration	0
Addr 0Dh bit [7:0]	Port 13's	R/W	EAP Configuration	0
Addr 0Eh bit [7:0]	Port 14's	R/W	EAP Configuration	0
Addr 0Fh bit [7:0]	Port 15's	R/W	EAP Configuration	0
Addr 10h bit [7:0]	Port 16's	R/W	EAP Configuration	0
Addr 11h bit [7:0]	Port 17's	R/W	EAP Configuration	0
Addr 12h bit [7:0]	Port 18's	R/W	EAP Configuration	0
Addr 13h bit [7:0]	Port 19's	R/W	EAP Configuration	0
Addr 14h bit [7:0]	Port 20's	R/W	EAP Configuration	0
Addr 15h bit [7:0]	Port 21's	R/W	EAP Configuration	0
Addr 16h bit [7:0]	Port 22's	R/W	EAP Configuration	0
Addr 17h bit [7:0]	Port 23's	R/W	EAP Configuration	0
Addr 18h bit [7:0]	IMP Port	R/W	EAP Configuration	0
Addr 19h bit [7:0]	GE port 0	R/W	EAP Configuration	0
Addr 1Ah bit [7:0]	GE port 1	R/W	EAP Configuration	0

**Table 300: EAP Configuration Register**

<b>Bit</b>	<b>Name</b>	<b>R/W</b>	<b>Description</b>	<b>Default</b>
7	ROAMING_OPTION	R/W	Address Roaming Support This bit is used when EAP_MODE = 2'b10. When a SA is learned at a port and subsequently moved to another port. The learned SA count is different depended on how this bit is set <ul style="list-style-type: none"> <li>0 = does not support Roaming. The same SA is thus learned twice. The learned SA count is set to 2</li> <li>1 = support address roaming. The learned SA count is set to 1</li> </ul>	0
6	SA_VIOLATION	R/W	This bit is used when EAP_MODE = 2'b01 or 2'b10 and incoming packet with SA violation (i.e., not in ARL table or exceeding learning limitation) <ul style="list-style-type: none"> <li>0 = drop</li> <li>1 = forward to IMP port</li> </ul>	0
5	DIS_LEARNING	R/W	<ul style="list-style-type: none"> <li>0 = learning enabled</li> <li>1 = learning disabled.</li> </ul>	0
4	EAP_EN_USER_DA	R/W	Enable EAP frame with user (unicast or multicast) DA. This is to change the definition of "special frame" defined under EAP_PORT_BLOCK <ul style="list-style-type: none"> <li>0 = do not support user DA EAP frame</li> <li>1 = support user DA EAP frame</li> </ul>	0
3:2	EAP_PORT_BLOCK	R/W	set local port to block mode (do not need this bit for management port) <ul style="list-style-type: none"> <li>00 = local port is not blocked</li> <li>01 = local port is blocked in ingress side</li> <li>10 = local port is blocked in both ingress and egress side. only 802.1x packet and special frame will be received.</li> <li>11 = Reserved</li> </ul>	0

**Table 300: EAP Configuration Register**

<b>Bit</b>	<b>Name</b>	<b>R/W</b>	<b>Description</b>	<b>Default</b>
1:0	EAP_MODE	R/W	Extend Mode <ul style="list-style-type: none"> <li>• 00 = Basic mode, SA will not be checked.</li> <li>• 01 = EAP Extended mode for unknown SA handling. For all nonEAP frame and nonEAP special frame only, check SA and port number. If unknown SA, drop or forward frame to IMP, and this unknown SA is not learned in ARL.</li> <li>• 10 = EAP Extended mode for SA limited learning handling. For all nonEAP frame and nonEAP special frame only, check SA learning limit. If current SA count exceeds max learn limit, drop or forward frame to IMP, and this violated SA is not learned in ARL.</li> <li>• 11 = Reserved</li> </ul>	0

## Port EAP Destination Address Register (Page 40h/Addr 20h–BCh)

See Table 302: “EAP Unicast Destination Address,” on page 320.

**Table 301: Port EAP Destination Address Register (Page: 40h, Address 20h–BCh)**

Bit	Name	R/W	Description	Default
Addr 20h bit [47:0]	Port 0's	R/W	EAP Unicast Destination Address Register	0
Addr 26h bit [47:0]	Port 1's	R/W	EAP Unicast Destination Address Register	0
Addr 2Ch bit [47:0]	Port 2's	R/W	EAP Unicast Destination Address Register	0
Addr 32h bit [47:0]	Port 3's	R/W	EAP Unicast Destination Address Register	0
Addr 38h bit [47:0]	Port 4's	R/W	EAP Unicast Destination Address Register	0
Addr 3Eh bit [47:0]	Port 5's	R/W	EAP Unicast Destination Address Register	0
Addr 44h bit [47:0]	Port 6's	R/W	EAP Unicast Destination Address Register	0
Addr 4Ah bit [47:0]	Port 7's	R/W	EAP Unicast Destination Address Register	0
Addr 50h bit [47:0]	Port 8's	R/W	EAP Unicast Destination Address Register	0
Addr 56h bit [47:0]	Port 9's	R/W	EAP Unicast Destination Address Register	0
Addr 5Ch bit [47:0]	Port 10's	R/W	EAP Unicast Destination Address Register	0
Addr 62h bit [47:0]	Port 11's	R/W	EAP Unicast Destination Address Register	0
Addr 68h bit [47:0]	Port 12's	R/W	EAP Unicast Destination Address Register	0
Addr 6Eh bit [47:0]	Port 13's	R/W	EAP Unicast Destination Address Register	0
Addr 74h bit [47:0]	Port 14's	R/W	EAP Unicast Destination Address Register	0
Addr 7Ah bit [47:0]	Port 15's	R/W	EAP Unicast Destination Address Register	0
Addr 80h bit [47:0]	Port 16's	R/W	EAP Unicast Destination Address Register	0
Addr 86h bit [47:0]	Port 17's	R/W	EAP Unicast Destination Address Register	0
Addr 8Ch bit [47:0]	Port 18's	R/W	EAP Unicast Destination Address Register	0
Addr 92h bit [47:0]	Port 19's	R/W	EAP Unicast Destination Address Register	0
Addr 98h bit [47:0]	Port 20's	R/W	EAP Unicast Destination Address Register	0
Addr 9Eh bit [47:0]	Port 21's	R/W	EAP Unicast Destination Address Register	0
Addr A4h bit [47:0]	Port 22's	R/W	EAP Unicast Destination Address Register	0
Addr AAh bit [47:0]	Port 23's	R/W	EAP Unicast Destination Address Register	0
Addr B0h bit [47:0]	IMP Port	R/W	EAP Unicast Destination Address Register	0
Addr B6h bit [47:0]	GE port 0	R/W	EAP Unicast Destination Address Register	0
Addr BCh bit [47:0]	GE port 1	R/W	EAP Unicast Destination Address Register	0

**Table 302: EAP Unicast Destination Address**

Bit	Name	R/W	Description	Default
63:48	RSVD	–	Reserved	0



**Table 302: EAP Unicast Destination Address**

<b>Bit</b>	<b>Name</b>	<b>R/W</b>	<b>Description</b>	<b>Default</b>
47:0	EAP_UNI_DA	R/W	EAP unicast DA	0

Broadcom Confidential

## Page 41h: 802.1x\_1 Registers

**Table 303: 802.1x\_1 Registers**

Addr	Bits	Description
00h–07h	64	“EAP Destination IP Register 0 (Page 41h/Addr 00h–07h)”
08h–1Fh	64	“EAP Destination IP Register 1 (Page 41h/Addr 08h–0Fh)” on page 322
10h	16	“EAP Global Configuration Register (Page 41h/Addr 10h–11h)” on page 322
18h	16	“Learning Counter Control Register (Page 41h/Addr 18h–19h)” on page 323
20h	16	“Port Max Learn Register (Page 41h/Addr 20h–5Fh)” on page 325
60h	16	“Port SA Count Register (Page 41h/Addr 60h–98h)” on page 326

### EAP Destination IP Register 0 (Page 41h/Addr 00h–07h)

**Table 304: EAP Destination IP Register 0 (Page 41h, Address 00h–07h)**

Bit	Name	R/W	Description	Default
63:32	DIP_SUB_REG_0	R/W	EAP Destination IP Subnet register 0	FFFFFFFF
31:0	DIP_MASK_REG_0	R/W	EAP Destination IP Mask register 0	FFFFFFFF

### EAP Destination IP Register 1 (Page 41h/Addr 08h–0Fh)

**Table 305: EAP Destination IP Register 1 (Page 41h, Address 08h–0Fh)**

Bit	Name	R/W	Description	Default
63:32	DIP_SUB_REG_1	R/W	EAP Destination IP Subnet register 1	FFFFFFFF
31:0	DIP_MASK_REG_1	R/W	EAP Destination IP Mask register 1	FFFFFFFF

### EAP Global Configuration Register (Page 41h/Addr 10h–11h)

**Table 306: EAP Global Configuration Register (Page 41h, Address 10h–11h)**

Bit	Name	R/W	Description	Default
15:13	RSVD	RO	Reserved Write default. Ignore on read.	0

**Table 306: EAP Global Configuration Register (Page 41h, Address 10h–11h) (Cont.)**

Bit	Name	R/W	Description	Default
12	EN_DHCP	R/W	DHCP Frame Control. When EAP_MODE is set, setting this bit to accept DHCP frames otherwise reject DHCP frames [Default]. <ul style="list-style-type: none"> <li>1 = Accept DHCP frames.</li> <li>0 = Reject DHCP frames.</li> </ul>	0
11	EN_DIP_1	R/W	Enable Destination IP Address when EAP_MODE is set. When set, IPv4 packet with destination IP address matched with EAP Destination IP register 1 passes.	0
10	EN_DIP_0	R/W	Enable Destination IP Address when EAP_MODE is set. When set, IPv4 packet with destination IP address matched with EAP Destination IP register 0 passes.	0
9	EN_ARP	R/W	Enable ARP frame when EAP_MODE is set. When set, ARP frame (DA = FF-FF-FF-FF-FF-FF and LT = 08-06) passes.	0
8	EN_MAC_22-2F	R/W	Enable (DA = 01-80-c2-00-00-22 ~ 01-80-c2-00-00-2F) frames passed when EAP_MODE is set.	0
7	EN_MAC_21	R/W	Enable (DA = 01-80-c2-00-00-21) frame passed when EAP_MODE is set.	0
6	EN_MAC_20	R/W	Enable (DA = 01-80-c2-00-00-20) frame passed when EAP_MODE is set.	0
5	EN_MAC_11-1F	R/W	Enable (DA = 01-80-c2-00-00-11 ~ 01-80-c2-00-00-1F) frames passed when EAP_MODE is set.	0
4	EN_MAC_10	R/W	Enable (DA = 01-80-c2-00-00-10) frame passed when EAP_MODE is set.	0
3	EN_MAC_02_04-0F	R/W	Enable (DA = 01-80-c2-00-00-02) or (DA = 01-80-c2-00-00-04 ~ 01-80-c2-00-00-040F) frame passed when EAP_MODE is set.	0
2	EN_MAC_BPDU	R/W	Enable BPDU frame passed when EAP_MODE is set.	0
1	RSVD	–	Reserved	0
0	EN_EAP_PT_CHK	R/W	Enable EAP Frame Packet Type Check.	0

## Learning Counter Control Register (Page 41h/Addr 18h–19h)

**Table 307: Learning counter Control Register (Page 40h, Address 18h–19h)**

Bit	Name	R/W	Description	Default
15	START/DONE	R/W	Start/Done command. Write 1 to initiate software learning counter control.	0

**Table 307: Learning counter Control Register (Page 40h, Address 18h–19h) (Cont.)**

<b>Bit</b>	<b>Name</b>	<b>R/W</b>	<b>Description</b>	<b>Default</b>
14:13	ACC_CTRL	R/W	Access Control 11 = Reset to 0 in corresponding port 10 = decrease by 1 in corresponding port 01 = increase by 1 in corresponding port 00 = no operation	0
12:6	RSVD	–	Reserved	0
5:0	PORT_NUMBER	R/W	Port Number	0

Broadcom Confidential

## Port Max Learn Register (Page 41h/Addr 20h–5Fh)

**Table 308: Port Max Learn Register (Page 41h/Addr 20h–5Fh)**

Address	Port	R/W	Description	Default
Addr 20h–21h bit [15:0]	Port 0	R/W	Max Learn Number of Addresses	0x1fff
Addr 22h–23h bit [15:0]	Port 1	R/W	Max Learn Number of Addresses	0x1fff
Addr 24h–25h bit [15:0]	Port 2	R/W	Max Learn Number of Addresses	0x1fff
Addr 26h–27h bit [15:0]	Port 3	R/W	Max Learn Number of Addresses	0x1fff
Addr 28h–29h bit [15:0]	Port 4	R/W	Max Learn Number of Addresses	0x1fff
Addr 2Ah–2Bh bit [15:0]	Port 5	R/W	Max Learn Number of Addresses	0x1fff
Addr 2Ch–2Dh bit [15:0]	Port 6	R/W	Max Learn Number of Addresses	0x1fff
Addr 2Eh–2Fh bit [15:0]	Port 7	R/W	Max Learn Number of Addresses	0x1fff
Addr 30h–31h bit [15:0]	Port 8	R/W	Max Learn Number of Addresses	0x1fff
Addr 32h–33h bit [15:0]	Port 9	R/W	Max Learn Number of Addresses	0x1fff
Addr 34h–35h bit [15:0]	Port 10	R/W	Max Learn Number of Addresses	0x1fff
Addr 36h–37h bit [15:0]	Port 11	R/W	Max Learn Number of Addresses	0x1fff
Addr 38h–39h bit [15:0]	Port 12	R/W	Max Learn Number of Addresses	0x1fff
Addr 3Ah–3Bh bit [15:0]	Port 13	R/W	Max Learn Number of Addresses	0x1fff
Addr 3Ch–3Dh bit [15:0]	Port 14	R/W	Max Learn Number of Addresses	0x1fff
Addr 3Eh–3Fh bit [15:0]	Port 15	R/W	Max Learn Number of Addresses	0x1fff
Addr 40h–41h bit [15:0]	Port 16	R/W	Max Learn Number of Addresses	0x1fff
Addr 42h–43h bit [15:0]	Port 17	R/W	Max Learn Number of Addresses	0x1fff
Addr 44h–45h bit [15:0]	Port 18	R/W	Max Learn Number of Addresses	0x1fff
Addr 46h–47h bit [15:0]	Port 19	R/W	Max Learn Number of Addresses	0x1fff
Addr 48h–49h bit [15:0]	Port 20	R/W	Max Learn Number of Addresses	0x1fff
Addr 4Ah–4Bh bit [15:0]	Port 21	R/W	Max Learn Number of Addresses	0x1fff
Addr 4Ch–4Dh bit [15:0]	Port 22	R/W	Max Learn Number of Addresses	0x1fff
Addr 4Eh–4Fh bit [15:0]	Port 23	R/W	Max Learn Number of Addresses	0x1fff
Addr 50h–51h bit [15:0]	IMP Port	R/W	Max Learn Number of Addresses	0x1fff
Addr 52h–53h bit [15:0]	GigaPort G0	R/W	Max Learn Number of Addresses	0x1fff
Addr 54h–55h bit [15:0]	GigaPort G1	R/W	Max Learn Number of Addresses	0x1fff

**Table 309: Max Learn Number of Address Register**

Bit	Name	R/W	Description	Default
15:13	RSVD	RO	Reserved Write default. Ignore on read.	0

**Table 309: Max Learn Number of Address Register**

Bit	Name	R/W	Description	Default
12:0	MAX_MAC_NUMBER	R/W	Dynamic Mode Maximum Number of MAC for each port.	0x1fff

## Port SA Count Register (Page 41h/Addr 60h–98h)

**Table 310: Port SA Count Register (Page: 41h, Address 60h–98h)**

Address	Port	R/W	Description	Default
Addr 60h–61h bit [15:0]	Port 0	R/W	SA count per port	0
Addr 62h–63h bit [15:0]	Port 1	R/W	SA count per port	0
Addr 64h–65h bit [15:0]	Port 2	R/W	SA count per port	0
Addr 66h–67h bit [15:0]	Port 3	R/W	SA count per port	0
Addr 68h–69h bit [15:0]	Port 4	R/W	SA count per port	0
Addr 6Ah–6Bh bit [15:0]	Port 5	R/W	SA count per port	0
Addr 6Ch–6Dh bit [15:0]	Port 6	R/W	SA count per port	0
Addr 6Eh–6Fh bit [15:0]	Port 7	R/W	SA count per port	0
Addr 70h–71h bit [15:0]	Port 8	R/W	SA count per port	0
Addr 72h–73h bit [15:0]	Port 9	R/W	SA count per port	0
Addr 74h–75h bit [15:0]	Port 10	R/W	SA count per port	0
Addr 76h–77h bit [15:0]	Port 11	R/W	SA count per port	0
Addr 78h–79h bit [15:0]	Port 12	R/W	SA count per port	0
Addr 7Ah–7Bh bit [15:0]	Port 13	R/W	SA count per port	0
Addr 7Ch–7Dh bit [15:0]	Port 14	R/W	SA count per port	0
Addr 7Eh–7Fh bit [15:0]	Port 15	R/W	SA count per port	0
Addr 80h–81h bit [15:0]	Port 16	R/W	SA count per port	0
Addr 82h–83h bit [15:0]	Port 17	R/W	SA count per port	0
Addr 84h–85h bit [15:0]	Port 18	R/W	SA count per port	0
Addr 86h–87h bit [15:0]	Port 19	R/W	SA count per port	0
Addr 88h–89h bit [15:0]	Port 20	R/W	SA count per port	0
Addr 8Ah–8Bh bit [15:0]	Port 21	R/W	SA count per port	0
Addr 8Ch–8Dh bit [15:0]	Port 22	R/W	SA count per port	0
Addr 8Eh–8Fh bit [15:0]	Port 23	R/W	SA count per port	0
Addr 90h–91h bit [15:0]	IMP Port	R/W	SA count per port	0
Addr 92h–93h bit [15:0]	GigaPort G0	R/W	SA count per port	0
Addr 94h–95h bit [15:0]	GigaPort G1	R/W	SA count per port	0

**Table 311: Port SA Count register**

<b>Bit</b>	<b>Name</b>	<b>R/W</b>	<b>Description</b>	<b>Default</b>
15:13	RSVD	RO	Reserved. Write default. Ignore on read.	0
12:0	CUR_SA_CNT	RO	Current SA count	0

Broadcom Confidential

## Page 43h: Rate Control Registers

**Table 312: Rate Control Registers (Page 43h)**

Addr	Bits	Description
00h	8	"Rate Control Memory Access Register (Page 43h/Addr 00h)" on page 328
01h	8	"Rate Control Memory Port Register (Page 43h/Addr 01h)" on page 329
10h–13h	32	"Rate Control Memory Data Register 0 (Page 43h/Addr 10h–13h)" on page 330
14h–17h	32	"Rate Control Memory Data Register 1 (Page 43h/Addr 14h–17h)" on page 331
18h–1Bh	32	"Rate Control Memory Data Register 2 (Page 43h/Addr 18h–1Bh)" on page 332
1Ch–1Fh	32	"Rate Control Memory Data Register 3 (Page 43h/Addr 1Ch–1Fh)" on page 333
20h–23h	32	"Rate Control Memory Data Register 4 (Page 43h/Addr 20h–23h)" on page 333
F0h–F7h	64	SPI Data I/O[0:7]
F8h–FDh	Reserved	
FEh	8	SPI Status
FFh	8	Page Register

### Rate Control Memory Access Register (Page 43h/Addr 00h)

**Table 313: Rate Control Memory Access Register (Page: 43h, Address 00h)**

Bit	Name	R/W	Description	Default
7	MEM_RW_START_DONE	R/W	Start/Done Command bit Write 1 to initiate a read or write process for a rate control memory. It will reset itself when the operation is completed.	0
6:3	RSVD	RO	• Reserved	0
2	EXTR_LNGTH_EN	R/W	Extra length calculate enable (only used for Ingress Rate Control) • 0 = disable • 1 = enable	0
1	INGRESS_EGRESS_IND	R/W	Ingress or Egress Indication • 0 = Ingress Rate Control Memory Access • 1 = Egress Rate Control Memory Access	0
0	READ_WRITE	R/W	Rate Control Memory Read/ Write • 0 = Write • 1 = Read	0



## Rate Control Memory Port Register (Page 43h/Addr 01h)

Table 314: Rate Control Memory Port Register (Page: 43h, Address 01h)

Bit	Name	R/W	Description	Default
7:6	RSVD	–	Reserved	0
5:0	RCM_PORT	R/W	Rate Control Memory Port Number <ul style="list-style-type: none"> <li>• 51~63: Reserved</li> <li>• 50: Giga Port G0</li> <li>• 49: Giga Port G0</li> <li>• 48: IMP Port</li> <li>• 24~47: 10/100 ports [port 0-port 23]</li> <li>• 0~23: Reserved</li> </ul>	0

Broadcom Confidential

## Rate Control Memory Data Register 0 (Page 43h/Addr 10h–13h)

**Table 315: Rate Control Memory Data Register 0 (Page: 43h, Address 10h)**

Bit	Name	R/W	Description	Default
31	ING_EG_RC_EN	R/W	Ingress and/or Egress Rate Control Enable <ul style="list-style-type: none"> <li>0 = Disable both Ingress and/or Egress Rate Control</li> <li>1 = Enable both Ingress and/or Egress Rate Control</li> </ul>	0
30	ING_RC_DROP_EN	R/W	This bit only applies to Ingress <ul style="list-style-type: none"> <li>0 = when over rate, pause.</li> <li>1 = when over rate, drop</li> </ul>	0
29	RSVD	–	Reserved	0
28:22	ING_RC_PKT_MASK_B0	R/W	This field is only applicable to Ingress Rate Control. Traffic correspond to the bit set will be masked from bucket. <ul style="list-style-type: none"> <li>Bit 28 = Unknown SA</li> <li>Bit 27 = Unicast Destination Lookup Failed Frame</li> <li>Bit 26 = Multicast Destination Lookup Failed Frame</li> <li>Bit 25 = Broadcast</li> <li>Bit 24 = Multicast Reserved Frame               <ul style="list-style-type: none"> <li>DA = 01-80-c2-00-00-00 ~ 2F</li> </ul> </li> <li>Bit 23 = Multicast Destination Lookup Hit Frame</li> <li>Bit 22 = Unicast Destination Lookup Hit Frame</li> </ul>	0
21:15	BUCKET_SIZE	R/W	For Ingress Rate Control: Bucket size, unit 8 KB (per bucket B0) For Egress Rate Control: Bucket size, unit 8 KB (total per port) <b>Note:</b> When rate control is enabled, BUCKET_SIZE cannot be set to 0.	0
14	REFRESH_UNIT	R/W	<ul style="list-style-type: none"> <li>0 = 62.5 Kbps</li> <li>1 = 1 Mbps</li> </ul> For Ingress Rate Control: per bucket B0 For Egress Rate Control: total per port	0
13:0	REFRESH_CNT	R/W	Refresh Count For Ingress Rate Control: per bucket B0 For Egress Rate Control: total per port <b>Note:</b> When rate control is enabled, REFRESH_CNT cannot be set to 0.	0

## Rate Control Memory Data Register 1 (Page 43h/Addr 14h–17h)

**Table 316: Rate Control Memory Data Register 1 (Page: 43h, Address 14h)**

Bit	Name	R/W	Description	Default
31	EG_RC_EN	R/W	Per Queue Egress Rate Control Enable <ul style="list-style-type: none"> <li>0 = Per Queue Egress Rate Control disable</li> <li>1 = Per Queue Egress Rate Control enable</li> </ul>	0
30:29	RSVD	–	Reserved	0
28:22	ING_RC_PKT_MASK_B1	R/W	This field is only applicable to Ingress Rate Control. Traffic correspond to the bit set will be masked from bucket. <ul style="list-style-type: none"> <li>Bit 28 = Unknown SA</li> <li>Bit 27 = Unicast Destination Lookup Failed Frame</li> <li>Bit 26 = Multicast Destination Lookup Failed Frame</li> <li>Bit 25 = Broadcast</li> <li>Bit 24 = Multicast Reserved Frame               <ul style="list-style-type: none"> <li>DA = 01-80-c2-00-00-00 ~ 2F</li> </ul> </li> <li>Bit 23 = Multicast Destination Lookup Hit Frame</li> <li>Bit 22 = Unicast Destination Lookup Hit Frame</li> </ul>	0
21:15	BUCKET_SIZE	R/W	For Ingress Rate Control: Bucket size, unit 8 KB (per bucket B1) For Egress Rate Control: Bucket size, unit 8 KB (for Queue 0) <b>Note:</b> When rate control is enabled, BUCKET_SIZE cannot be set to 0.	0
14	REFRESH_UNIT	R/W	<ul style="list-style-type: none"> <li>0 = 62.5 Kbps</li> <li>1 = 1 Mbps</li> </ul> For Ingress Rate Control: per bucket B1 For Egress Rate Control: for Queue 0	0
13:0	REFRESH_CNT	R/W	Refresh Count, For Ingress Rate Control: per bucket B1 For Egress Rate Control: for Queue 0 <b>Note:</b> When rate control is enabled, REFRESH_CNT cannot be set to 0.	0

## Rate Control Memory Data Register 2 (Page 43h/Addr 18h–1Bh)

**Table 317: Rate Control Memory Data Register 2 (Page: 43h, Address 18h)**

Bit	Name	R/W	Description	Default
31:29	RSVD	–	Reserved	0
28:22	ING_RC_PKT_MASK_B2	R/W	<p>This field is only applicable to Ingress Rate Control.</p> <p>Traffic correspond to the bit set will be masked from bucket.</p> <ul style="list-style-type: none"> <li>• Bit 28 = Unknown SA</li> <li>• Bit 27 = Unicast Destination Lookup Failed Frame</li> <li>• Bit 26 = Multicast Destination Lookup Failed Frame</li> <li>• Bit 25 = Broadcast</li> <li>• Bit 24 = Multicast Reserved Frame               <ul style="list-style-type: none"> <li>• DA = 01-80-c2-00-00-00-2F</li> </ul> </li> <li>• Bit 23 = Multicast Destination Lookup Hit Frame</li> <li>• Bit 22 = Unicast Destination Lookup Hit Frame</li> </ul>	0
21:15	BUCKET_SIZE	R/W	<p>For Ingress Rate Control: Bucket size, unit 8 KB (per bucket B2)</p> <p>For Egress Rate Control: Bucket size, unit 8 KB (for Queue 1)</p> <p><b>Note:</b> When rate control is enabled, BUCKET_SIZE cannot be set to 0.</p>	0
14	REFRESH_UNIT	R/W	<ul style="list-style-type: none"> <li>• 0 = 62.5 Kbps</li> <li>• 1 = 1 Mbps</li> </ul> <p>For Ingress Rate Control: per bucket B2</p> <p>For Egress Rate Control: for Queue 1</p>	0
13:0	REFRESH_CNT	R/W	<p>Refresh Count,</p> <p>For Ingress Rate Control: per bucket B2</p> <p>For Egress Rate Control: for Queue 1</p> <p><b>Note:</b> When rate control is enabled, REFRESH_CNT cannot be set to 0.</p>	0

## Rate Control Memory Data Register 3 (Page 43h/Addr 1Ch–1Fh)

**Table 318: Rate Control Memory Data Register 3 (Page: 43h, Address 1Ch)**

Bit	Name	R/W	Description	Default
31:22	RSVD	–	Reserved	0
21:15	BUCKET_SIZE	R/W	For Egress Rate Control: Bucket size, unit 8 KB (for Queue 2) <b>Note:</b> When rate control is enabled, BUCKET_SIZE cannot be set to 0.	0
14	REFRESH_UNIT	R/W	<ul style="list-style-type: none"> <li>• 0 = 62.5 Kbps</li> <li>• 1 = 1 Mbps</li> </ul> For Egress Rate Control: for Queue 2	0
13:0	REFRESH_CNT	R/W	Refresh Count for Egress Rate Control: for Queue 2 <b>Note:</b> When rate control is enabled, REFRESH_CNT cannot be set to 0.	0

## Rate Control Memory Data Register 4 (Page 43h/Addr 20h–23h)

**Table 319: Rate Control Memory Data Register 4 (Page: 43h, Address 20h)**

Bit	Name	R/W	Description	Default
31:22	RSVD	–	Reserved	0
21:15	BUCKET_SIZE	R/W	For Egress Rate Control: Bucket size, unit 8 KB (for Queue 3) <b>Note:</b> When rate control is enabled, BUCKET_SIZE cannot be set to 0.	0
14	REFRESH_UNIT	R/W	<ul style="list-style-type: none"> <li>• 0 = 62.5 Kbps</li> <li>• 1 = 1 Mbps</li> </ul> For Egress Rate Control: for Queue 3	0
13:0	REFRESH_CNT	R/W	Refresh Count for Egress Rate Control: for Queue 3 <b>Note:</b> When rate control is enabled, REFRESH_CNT cannot be set to 0.	0

## Page 45h: 802.1s Multiple Spanning Tree Registers

**Table 320: 802.1s Multiple Spanning Tree Registers (Page 45h)**

<i>Addr</i>	<i>Bits</i>	<i>Description</i>
00h	8	Multiple Spanning Trees “MST Control Register (Page 45h/Addr 00h)” on page 334
01h–03h	Reserved	
04h–07h	32	“Age-out Control Register (Page 45h/Addr 04h–07h)” on page 335
08h–EFh	Reserved	
F0h–F7h	64	SPI Data I/O[0:7]
F8h–FDh	Reserved	
FEh	8	SPI Status
FFh	8	Page Register

### MST Control Register (Page 45h/Addr 00h)

**Table 321: MST Control Register (Page 45h, Address 00h)**

<i>Bit</i>	<i>Name</i>	<i>R/W</i>	<i>Description</i>	<i>Default</i>
7	START/DONE	R/W	Fast Ageing Start/Done Command. Write as 1 to initiate the fast ageing process following the AGE_MODE setting. When fast ageing process is done, this bit clears to 0.	0
6	RSVD	RO	Reserved. Write default. Ignore on read.	0
5	UPD_STATIC_EN	R/W	1 = AGE bit in static entry will be updated 0 = AGE bit in static entry will not be updated (default)	0
4	AGE_STATIC_EN	R/W	Static Entry Ageing Enable. 1 = Allow ageing static entries in ARL. 0 = Normal mode.	
3	AGE_MODE_SPT	R/W	Ageing Mode Control Per Spanning Tree. Follow the SPT_AGE_EN setting.	0
2	AGE_MODE_VLAN	R/W	Ageing Mode Control Per VLAN. Follow the AGE_EN_VID setting.	0
1	AGE_MODE_PORT	R/W	Ageing Mode Control. Per-port, follows the per-port AGE_EN_PORT setting.	0

**Table 321: MST Control Register (Page 45h, Address 00h)**

<b>Bit</b>	<b>Name</b>	<b>R/W</b>	<b>Description</b>	<b>Default</b>
0	En_802_1s	R/W	Spanning Tree Enable. <ul style="list-style-type: none"> <li>1 = Support 802.1s (MST); spanning tree status is fetched from MST_table.</li> <li>0 = Only one spanning tree supported. (Original mode).</li> </ul>	0

**Age-out Control Register (Page 45h/Addr 04h–07h)****Table 322: Age-Out Control Register (Page 45h, Address 04h–07h)**

<b>Bit</b>	<b>Name</b>	<b>R/W</b>	<b>Description</b>	<b>Default</b>
31:26	RSVD	RO	Reserved. Write default. Ignore on read.	0
25:18	SPT_AGE_EN	R/W	MAC Address Ageing Control Per SPD ID. These bits specify a SPD ID. MAC Addresses that are associated with the SPD ID are age out in the auto ageing process.	0
17:6	AGE_EN_VID	R/W	MAC Address Ageing Control Per VID. These bits specify a VID. MAC Addresses that are associated with the VID are age out in the auto ageing process.	0
5:0	AGE_EN_PORT	R/W	MAC Address Ageing Control Per Port. These bits specify a port number. MAC Addresses that are associated with the port number are aged out in the auto ageing process. <ul style="list-style-type: none"> <li>50 = Port number for GigaPort G1</li> <li>49 = Port number for GigaPort G0</li> <li>48 = Port number for IMP</li> <li>24~47 = Port numbers for 10/100 ports [port 0-port 23]</li> <li>0 ~ 23 = Reserved</li> </ul>	0

## Page 68h–84h: Port MIB Registers

Per-port MIB counters reside within pages 68h through 84h. The contents of each page is listed in [Table 323](#).

- Page 68h contains port MIB counters for port 0
- Page 69h contains port MIB counters for port 1
- ...
- Page 78h contains port MIB counters for port 16
- ...
- Page 80h contains port MIB counters for IMP port
- Page 81h contains port MIB counters for G0 port
- Page 82h contains port MIB counters for G1 port

**Table 323: Port MIB Registers (Page 68h–84h)**

Address	Bits	Description
00h–07h	64	TxOctets
08h–0Bh	32	TxDropPkts
0Ch–0Fh	32	TxPausePkts
10h–13h	32	TxBroadcastPkts
14h–17h	32	TxMulticastPkts
18h–1Bh	32	TxUnicastPkts
1Ch–1Fh	32	TxCollisions <sup>a</sup>
20h–23h	32	TxSingleCollision <sup>a</sup>
24h–27h	32	TxMultipleCollision <sup>a</sup>
2Ch–2Fh	32	TxLateCollision <sup>a</sup>
34h–37h	32	TxFramelnDisc
38h–3Bh	32	TxQoS0Pkts
3Ch–43h	64	TxQoS0Octets
0x44h–47h	32	TxQoS1Pkts
0x48h–4Fh	64	TxQoS1Octets
0x50h–53h	32	TxQoS2Pkts
0x54h–5Bh	64	TxQoS2Octets
0x5Ch–5Fh	32	TxQoS3Pkts
0x60h–67h	64	TxQoS3Octets
68h–6Fh	64	RxOctets
70h–73h	32	RxUndersizePkts <sup>a</sup>
74h–77h	32	RxPausePkts
78h–7Bh	32	Pkts64Octets
7Ch–7Fh	32	Pkts65to127Octets



**Table 323: Port MIB Registers (Page 68h–84h) (Cont.)**

<b>Address</b>	<b>Bits</b>	<b>Description</b>
80h–83h	32	Pkts128to255Octets
84h–87h	32	Pkts256to511Octets
88h–8Bh	32	Pkts512to1023Octets
8Ch–8Fh	32	Pkts1024toMaxOctets (Revision B silicon) Pkts1024to1522Octets (Revision A silicon)
90h–93h	32	RxOversizePkts
94–97h	32	RxJabbers
98h–9Bh	32	RxAlignmentErrors
9Ch–9Fh	32	RxFCSErrors
A0h–A7h	64	RxGoodOctets
ACh–AFh	32	RxUnicastPkts
B0h–B3h	32	RxMulticastPkts
B4h–B7h	32	RxBroadcastPkts
B8h–BBh	32	RxSAChanges
BCh–BFh	32	RxFragments <sup>a</sup>
C0h–C3h	32	RxExcessSizeDisc
C4h–C7h	32	RXSymbolError
C8h–CBh	32	RxDiscPkts
CCh–EFh	Reserved	
F0h–F7h	64	SPI Data I/O[0:7]
F8h–FDh	Reserved	
FEh	8	SPI Status
FFh	32	Page Register

a = To save bandwidth, 3-bit counters are used internally to accumulate all (collision, undersize, or fragment) events at local ports. When either the 3-bit counters count to 7 or a normal packet (64-byte or longer) is received, the corresponding MIB counters update once.

## Page 85h: Snapshot Port MIB Registers

Snapshot Port MIB counters reside within pages 85h. The contents is listed in [Table 324](#).

**Table 324: Snapshot Port MIB Registers (Page 85h)**

<b>Address</b>	<b>Bits</b>	<b>Description</b>
00h–07h	64	TxOctets
08h–0Bh	32	TxDropPkts
0Ch–0Fh	32	TxPausePkts
10h–13h	32	TxBroadcastPkts
14h–17h	32	TxMulticastPkts
18h–1Bh	32	TxUnicastPkts
1Ch–1Fh	32	TxCollisions <sup>a</sup>
20h–23h	32	TxSingleCollision <sup>a</sup>
24h–27h	32	TxMultipleCollision <sup>a</sup>
28h–2Bh	32	TxDeferredTransmit
2Ch–2Fh	32	TxLateCollision <sup>a</sup>
30h–33h	32	TxExcessiveCollision <sup>a</sup>
34h–37h	32	TxFramelnDisc
38h–3Bh	32	TxQoS0Pkts
3Ch–43h	64	TxQoS0Octets
0x44h–47h	32	TxQoS1Pkts
0x48h–4Fh	64	TxQoS1Octets
0x50h–53h	32	TxQoS2Pkts
0x54h–5Bh	64	TxQoS2Octets
0x5Ch–5Fh	32	TxQoS3Pkts
0x60h–67h	64	TxQoS3Octets
68h–6Fh	64	RxOctets
70h–73h	32	RxUndersizePkts <sup>a</sup>
74h–77h	32	RxPausePkts
78h–7Bh	32	Pkts64Octets
7Ch–7Fh	32	Pkts65to127Octets
80h–83h	32	Pkts128to255Octets
84h–87h	32	Pkts256to511Octets
88h–8Bh	32	Pkts512to1023Octets
8Ch–8Fh	32	Pkts1024toMaxOctets (Revision B silicon) Pkts1024to1522Octets (Revision A silicon)
90h–93h	32	RxOversizePkts

**Table 324: Snapshot Port MIB Registers (Page 85h) (Cont.)**

<b>Address</b>	<b>Bits</b>	<b>Description</b>
94–97h	32	RxJabbers
98h–9Bh	32	RxAlignmentErrors
9Ch–9Fh	32	RxFCSErrors
A0h–A7h	64	RxGoodOctets
A8h–ABh	32	RxDropPkts
ACh–AFh	32	RxUnicastPkts
B0h–B3h	32	RxMulticastPkts
B4h–B7h	32	RxBroadcastPkts
B8h–BBh	32	RxSACanges
BCh–BFh	32	RxFragments <sup>a</sup>
C0h–C3h	32	RxExcessSizeDisc
C4h–C7h	32	RXSymbolError
C8h–CBh	32	RxDiscPkts
CCh–EFh	Reserved	
F0h–F7h	64	SPI Data I/O[0:7]
F8h–FDh	Reserved	
FEh	8	SPI Status
FFh	32	Page Register

a = To save bandwidth, 3-bit counters are used internally to accumulate all (collision, undersize, or fragment) events at local ports. When either the 3-bit counters count to 7 or a normal packet (64-byte or longer) is received, the corresponding MIB counters update once.

## Page A0h–B7h: FE Ports 0-23 MII Registers

See “MDC/MDIO Interface” on page 114 for more information on PHY addressing.

**Table 325: FE Port MII Registers Page Versus PHY**

<i>Page</i>	<i>Port #</i>	<i>Hardware PHY address</i>
A0h	0	00000
A1h	1	00001
A2h	2	00010
A3h	3	00011
A4h	4	00100
A5h	5	00101
A6h	6	00110
A7h	7	00111
A8h	8	01000
A9h	9	01001
AAh	10	01010
ABh	11	01011
ACH	12	01101
ADh	13	01100
Aeh	14	01101
Afh	15	01110
B0h	16	01111
B1h	17	10000
B2h	18	10001
B3h	19	10010
B4h	20	10011
B5h	21	10100
B6h	22	10101
B7h	23	10110

**Table 326: Port MII Registers (Page A0h–B7h)**

<i>Address</i>	<i>Bits</i>	<i>Description</i>
00h–01h	16	“MII Control Register (Page A0h–B7h/Addr 00h–01h)” on page 342
02h–03h	16	“MII Status Register (Page A0h–B7h/Addr 02h–03h)” on page 344

**Table 326: Port MII Registers (Cont.)(Page A0h–B7h)**

<b>Address</b>	<b>Bits</b>	<b>Description</b>
08h–09h	16	“Auto-Negotiation Advertisement Register (Page A0h–B7h/Addr 08h–09h)” on page 347
0Ah–0Bh	16	“Auto-Negotiation Link Partner Ability Register (Page A0h–B7h/Addr 0Ah–0Bh)” on page 348
0Ch–0Dh	16	“Auto-Negotiation Expansion Register (Page A0h–B7h/Addr 0Ch–0Dh)” on page 349
0Eh–0Fh	16	“Auto-Negotiation Next Page Register (Page A0h–B7h/Addr 0Eh–0Fh)” on page 351
10h–11h	16	“Link Partner Next Page Register (Page A0h–B7h/Addr 10h–11h)” on page 352
12h–1Fh	Reserved	
20h–3Fh	–	Reserved

## MII Control Register (Page A0h–B7h/Addr 00h–01h)

**Table 327: MII Control Register (Pages A0h–B7h, Address 00h–01h)**

Bit	Name	R/W	Description	Default
15	Reset	R/W (SC)	<ul style="list-style-type: none"> <li>1 = PHY reset.</li> <li>0 = Normal operation.</li> </ul>	0
14	Loopback	R/W	<ul style="list-style-type: none"> <li>1 = Loopback mode.</li> <li>0 = Normal operation.</li> </ul>	0
13	Forced Speed Selection	R/W	<ul style="list-style-type: none"> <li>1 = 100 Mbps.</li> <li>0 = 10 Mbps.</li> </ul>	1
12	Auto-negotiation Enable	R/W	<ul style="list-style-type: none"> <li>1 = Auto-negotiation enable.</li> <li>0 = Auto-negotiation disable.</li> </ul>	1
11	Power Down	RO	<ul style="list-style-type: none"> <li>0 = Normal operation.</li> <li>The BCM53242M does not implement a low-power mode.</li> </ul>	0
10	Isolate	R/W	<ul style="list-style-type: none"> <li>1 = Electrically isolate PHY from MII.</li> <li>0 = Normal operation.</li> </ul>	0
9	Restart Auto-negotiation	R/W (SC)	<ul style="list-style-type: none"> <li>1 = Restart auto-negotiation process.</li> <li>0 = Normal operation.</li> </ul>	0
8	Duplex Mode	R/W	<ul style="list-style-type: none"> <li>1 = Full-duplex.</li> <li>0 = Half-duplex.</li> </ul>	0
7:0	Reserved	RO	Ignore when read.	0

**Note:** R/W = Read/Write, RO = Read only, SC = Self Clear, LL = Latched Low, LH = Latched High, LL and LH Clear after read operation.

### Reset

To reset an individual part PHY, the BCM53242M by software control, a 1 must be written to bit 15 of the Control register using an MII write operation. The bit clears itself after the reset process is complete, and need not be cleared using a second MII write. Writes to other Control register bits have no effect until the reset process is completed, which requires approximately 1  $\mu$ s. Writing a 0 to this bit has no effect. Because this bit is self-clearing, after a few cycles from a write operation, it returns a 0 when read.

### Loopback

An individual part of the BCM53242M can be placed into loopback mode by writing a 1 to bit 14 of the Control register. The loopback mode can be cleared by writing a 0 to bit 14 of the control register, or by resetting the chip. When this bit is read, it returns a 1 when the chip is in software-controlled loopback modes; otherwise it returns a 0.

## Forced Speed Selection

If auto-negotiation is enabled, this bit has no effect on the speed selection. However, if auto-negotiation is disabled by software control, the operating speed of the BCM53242M port can be forced by writing the appropriate value to bit 13 of the Control register. Writing a 1 to this bit forces 100Base-X operation, while writing a 0 forces 10Base-T operation. When this bit is read, it returns the value of the software-controlled forced speed selection only. To read the overall state of forced speed selection, including both hardware and software control, use bit 8 of the Auxiliary Control register.

## Auto-Negotiation Enable

Auto-negotiation is enabled by default. If bit 12 of the Control register is written with a value of 0, auto-negotiation is disabled by software control. Writing a 1 to the same bit of the Control register or resetting the chip re-enables auto-negotiation. When read, this bit returns the value most recently written to this location, or 1 if it has not been written since the last chip reset.

## Power Down

The BCM53242M does not implement a low-power mode.

## Isolate

Each individual PHY can be isolated from its Media Independent Interface by writing a 1 to bit 10 of the Control register. All MII outputs are tri-stated and all MII inputs are ignored. Because the MII management interface is still active, the isolate mode can be cleared by writing a 0 to bit 10 of the control register, or by resetting the chip. When this bit is read, it returns a 1 when the chip is in isolate mode; otherwise it returns a 0.

## Restart Auto-Negotiation

Bit 9 of the Control register is a self-clearing bit that allows the auto-negotiation process to be restarted, regardless of the current status of the auto-negotiation state machine. For this bit to have an effect, auto-negotiation must be enabled. Writing a 1 to this bit restarts the auto-negotiation, while writing a 0 to this bit has no effect. Because the bit is self-clearing after only a few cycles, it always returns a 0 when read. The operation of this bit is identical to bit 9 of the Auxiliary Multiple PHY register.

## Duplex Mode

By default, at reset this bit indicates BCM53242M half-duplex mode. If the Auto-negotiation is enabled, this bit has no effect on the duplex selection. The chip can be forced into full-duplex mode by writing a 1 to bit 8 of the Control register while auto-negotiation is disabled. Half-duplex mode can be resumed by writing a 0 to bit 8 of the control register, or by resetting the chip.

## Reserved Bits

All reserved MII register bits must be written as 0 at all times. Ignore the BCM53242M output when these bits are read.

## MII Status Register (Page A0h–B7h/Addr 02h–03h)

**Table 328: MII Status Register (Pages A0h–B7h, Address 02h–03h)**

Bit	Name	R/W	Description	Default
15	100Base-T4 Capability	RO	0 = Not 100Base-T4 capable.	0
14	100Base-TX FDX Capability	RO	1 = 100Base-TX full-duplex capable.	1
13	100Base-TX Capability	RO	1 = 100Base-TX half-duplex capable.	1
12	10Base-T FDX Capability	RO	1 = 10Base-T full-duplex capable.	1
11	10Base-T Capability	RO	1 = 10Base-T half-duplex capable.	1
10:7	Reserved	RO	Ignore when read.	0
6	MF Preamble Suppression	R/W	<ul style="list-style-type: none"> <li>1 = Preamble may be suppressed.</li> <li>0 = Preamble always required.</li> </ul>	0
5	Auto-negotiation Complete	RO	<ul style="list-style-type: none"> <li>1 = Auto-negotiation process completed.</li> <li>0 = Auto-negotiation process not completed.</li> </ul>	0
4	Remote Fault	RO LH	<ul style="list-style-type: none"> <li>1 = Remote/far-end fault condition detected.</li> <li>0 = No remote/far-end fault condition detected.</li> </ul>	0
3	Auto-negotiation Capability	RO	<ul style="list-style-type: none"> <li>1 = Auto-negotiation capable.</li> <li>0 = Not auto-negotiation capable.</li> </ul>	1
2	Link Status	RO LL	<ul style="list-style-type: none"> <li>1 = Link is up (Link Pass state).</li> <li>0 = Link is down (Link Fail state).</li> </ul>	0
1	Jabber Detect	RO LH	<ul style="list-style-type: none"> <li>1 = Jabber condition detected.</li> <li>0 = No jabber condition detected.</li> </ul>	0
0	Extended Capability	RO	1 = Extended register capable.	1

**Note:** R/W = Read/Write, RO = Read only, SC = Self Clear, LL = Latched Low, LH = Latched High, LL & LH Clear after read operation.

### 100Base-T4 Capability

The BCM53242M is not capable of 100Base-T4 operation, and returns a 0 when bit 15 of the status register is read.

### 100Base-X Full-Duplex Capability

The BCM53242M is capable of 100Base-X full-duplex operation, and returns a 1 when bit 14 of the Status register is read.

### 100Base-X Half-Duplex Capability

The BCM53242M is capable of 100Base-X half-duplex operation, and returns a 1 when bit 13 of the Status register is read.



## 10Base-T Full-Duplex Capability

The BCM53242M is capable of 10Base-T full-duplex operation, and returns a 1 when bit 12 of the Status register is read.

## 10Base-T Half-Duplex Capability

The BCM53242M is capable of 10Base-T half-duplex operation, and returns a 1 when bit 11 of the Status register is read.

## Reserved Bit

Ignore the BCM53242M output when these bits are read.

## MF Preamble Suppression

This bit is the only writable bit in the Status register. Setting this bit to a 1 allows subsequent MII management frames to be accepted with or without the standard preamble pattern. When Preamble Suppression is enabled, only 2 preamble bits are required between successive Management Commands, instead of the normal 32.

## Auto-Negotiation Complete

Bit 5 of the Status register returns a 1 if the auto-negotiation process has been completed and the contents of registers 4, 5 and 6 are valid.

## Remote Fault

When set at the completion of auto-negotiation, indicates that a remote fault condition has been signaled by the link partner. When set in 100Base-FX mode, indicates that a far-end fault condition has been detected. This bit is latched high, and self-clears when read. Is immediately set once again in FX mode after clearing if the far-end fault condition remains true.

## Auto-Negotiation Capability

The BCM53242M can perform IEEE auto-negotiation, and returns a 1 when bit 4 of the Status register is read, regardless of whether the auto-negotiation function has been disabled.

## Link Status

The BCM53242M returns a 1 on bit 2 of the Status register when the link state machine is in Link Pass, indicating that a valid link has been established. Otherwise, it returns 0. When a link failure occurs after the Link Pass state has been entered, the Link Status bit is latched at 0 and remains so until the bit is read. After the bit is read, it becomes 1 if the Link Pass state has been entered again.

## Jabber Detect

10Base-T operation only. The BCM53242M returns a 1 on bit 1 of the Status register if a jabber condition has been detected. After the bit is read, or if the chip is reset, it reverts to 0.

## Extended Capability

The BCM53242M supports extended capability registers, and returns a 1 when bit 0 of the Status register is read. Several extended registers have been implemented in the BCM53242M, and their bit functions are defined later in this section.

Broadcom Confidential

## PHY Identifier Registers (Page A0h–B7h/Addr 04h–07h)

**Table 329: PHY Identifier Registers (Pages A0h–B7h, Addresses 04h–05h and 06h–07h)**

Bit	Name	R/W	Description	Default
15:0	MII Address 00010	RO	PHYID HIGH	0143h
15:0	MII Address 00011	RO	PHYID LOW	BF1Nh <sup>a</sup>

a. Refer to [Table 210 on page 259](#) for the value of N and the associated chip revision.

## Auto-Negotiation Advertisement Register (Page A0h–B7h/Addr 08h–09h)

**Table 330: Auto-Negotiation Advertisement Register (Pages A0h–B7h, Address 08h–09h)**

Bit	Name	R/W	Description	Default
15	Next Page	R/W	<ul style="list-style-type: none"> <li>1 = Next Page Operation supported.</li> <li>0 = Next Page Operation disabled.</li> </ul>	0
14	Reserved	RO	Ignore when Read.	–
13	Remote Fault	R/W	1 = Transmit Remote Fault.	0
12:11	Reserved Technologies	RO	Ignore when Read.	–
10	Advertise Pause Capability	R/W	1 = Pause Operation for full-duplex.	1
9	Advertise 100Base-T4	R/W	0 = Do Not Advertise T4 Capability.	0
8	Advertise 100Base-X FDX	R/W	<ul style="list-style-type: none"> <li>1 = Advertise 100Base-X full-duplex.</li> <li>0 = Do Not Advertise 100Base-X full-duplex.</li> </ul>	1
7	Advertise 100Base-X	R/W	1 = Advertise 100Base-X.	1
6	Advertise 10Base-T FDX	R/W	<ul style="list-style-type: none"> <li>1 = Advertise 10Base-T full-duplex.</li> <li>0 = Do Not Advertise 10Base-T full-duplex.</li> </ul>	1
5	Advertise 10Base-T	R/W	1 = Advertise 10Base-T.	1
4:0	Advertise Selector Field	R/W	Fixed value: indicates 802.3.	00001

### Next Page

The BCM53242M supports the Next Page function. To enable this operation, write a 1 to this bit.

### Remote Fault

Writing a 1 to bit 13 of the Advertisement register sends a Remote Fault indicator to the Link Partner during auto-negotiation. Writing a 0 to this bit or resetting the chip clears the Remote Fault transmission bit. This bit returns the value last written to it, or else 0 if no write has been completed since the last chip reset.

## Reserved Bits

Ignore output when read.

## Pause Operation for Full-Duplex Links

The use of this bit is independent of the negotiated data rate, medium, or link technology. The setting of this bit indicates the availability of additional DTE capability when full-duplex operation is in use. This bit is used by one MAC to communicate Pause Capability to its Link Partner and has no effect on PHY operation.

## Advertisement Bits

Use bits 9:5 of the Advertisement register to customize the ability information transmitted to the Link Partner. The default value for each bit reflects the abilities of the BCM53242M. By writing a 1 to any of the bits, the corresponding ability is transmitted to the Link Partner. Writing a 0 to any bit causes the corresponding ability to be suppressed from transmission. Resetting the chip restores the default bit values. Reading the register returns the values last written to the corresponding bits, or else the default values if no write has been completed since the last chip reset.

## Selector Field

Bits 4:0 of the Advertisement register contain the value 00001, indicating that the chip belongs to the 802.3 class of PHY transceivers

## Auto-Negotiation Link Partner Ability Register (Page A0h–B7h/Addr 0Ah–0Bh)

*Table 331: Auto-Negotiation Link Partner Ability Register (Pages A0h–B7h, Address 0Ah–0Bh)*

<b>Bit</b>	<b>Name</b>	<b>R/W</b>	<b>Description</b>	<b>Default</b>
15	LP Next Page	RO	Link Partner next page bit.	0
14	LP Acknowledge	RO	Link Partner acknowledge bit.	0
13	LP Remote Fault	RO	Link Partner remote fault indicator.	0
12:11	Reserved Technologies	RO	Ignore when read.	000
10	LP Advertise Pause	RO	Link Partner has Pause Capability.	0
9	LP Advertise 100Base-T4	RO	Link Partner has 100Base-T4 capability.	0
8	LP Advertise 100Base-X FDX	RO	Link Partner has 100Base-X FDX capability.	0
7	LP Advertise 100Base-X	RO	Link Partner has 100Base-X capability.	0
6	LP Advertise 10Base-T FDX	RO	Link Partner has 10Base-T FDX capability.	0
5	LP Advertise 10Base-T	RO	Link Partner has 10Base-T capability.	0
4:0	Link Partner Selector Field	RO	Link Partner selector field.	00000

The values contained in the Auto-negotiation Link Partner Ability register are only guaranteed to be valid after auto-negotiation has successfully completed, as indicated by bit 5 of the MII Status register.

## Next Page

Bit 15 of the Link Partner Ability register returns a value of 1 when the Link Partner implements the Next Page function and has Next Page information to transmit.

## Acknowledge

Bit 14 of the Link Partner Ability register is used by auto-negotiation to indicate that a device has successfully received its Link Partner's Link Code Word.

## Remote Fault

Bit 13 of the Link Partner Ability register returns a value of 1 when the Link Partner signals that a remote fault has occurred. The BCM53242M simply copies the value to this register and does not act upon it.

## Reserved Bits

Ignore when read.

## Pause

Indicates that the Link Partner pause bit is set.

## Advertisement Bits

Bits 9:5 of the Link Partner Ability register reflect the abilities of the Link Partner. A 1 on any of these bits indicates that the Link Partner is capable of performing the corresponding mode of operation. Bits 9:5 are cleared any time auto-negotiation is restarted or the BCM53242M is reset.

## Selector Field

Bits 4:0 of the Link Partner Ability register reflect the value of the Link Partner's selector field. These bits are cleared any time auto-negotiation is restarted or the chip is reset.

## Auto-Negotiation Expansion Register (Page A0h–B7h/Addr 0Ch–0Dh)

**Table 332: Auto-Negotiation Expansion Register (Pages A0h–B7h, Address 0Ch–0Dh)**

Bit	Name	R/W	Description	Default
15:5	Reserved	RO	Ignore when read.	
4	Parallel Detection Fault	RO LH	<ul style="list-style-type: none"> <li>1 = Parallel Detection fault.</li> <li>0 = No Parallel Detection fault.</li> </ul>	0

**Table 332: Auto-Negotiation Expansion Register (Pages A0h–B7h, Address 0Ch–0Dh)**

Bit	Name	R/W	Description	Default
3	Link Partner Next Page Able	RO	<ul style="list-style-type: none"> <li>1 = Link Partner has Next Page capability.</li> <li>0 = Link Partner does not have Next Page capability.</li> </ul>	0
2	Next Page Able	RO	<ul style="list-style-type: none"> <li>1 = Next Page is enabled.</li> <li>0 = Next Page capability.</li> </ul>	–
1	Page Received	RO	<ul style="list-style-type: none"> <li>1 = New page has been received.</li> <li>0 = New page has not been received.</li> </ul>	0
0	Link Partner Auto-negotiation Able	RO LH	<ul style="list-style-type: none"> <li>1 = Link Partner has auto-negotiation capability.</li> <li>0 = Link Partner does not have auto-negotiation capability.</li> </ul>	0

**Note:** R/W = Read/Write, RO = Read only, SC = Self Clear, LL = Latched Low, LH = Latched High, LL and LH clear after read operation.

## Parallel Detection Fault

Bit 4 of the Auto-negotiation Expansion register is a read-only bit that gets latched high when a parallel detection fault occurs in the auto-negotiation state machine. For further details, please consult the IEEE standard. The bit is reset to 0 after the register is read, or when the chip is reset.

## Link Partner Next Page Able

Bit 3 of the Auto-negotiation Expansion register returns a 1 when the Link Partner has Next Page capabilities. It has the same value as bit 15 of the Link Partner Ability register.

## Page Received

Bit 1 of the Auto-negotiation Expansion register is latched high when a new Link Code Word is received from the Link Partner, checked, and acknowledged. It remains high until the register is read, or until the chip is reset.

## Link Partner Auto-Negotiation Able

Bit 0 of the Auto-negotiation Expansion register returns a 1 when the Link Partner is known to have auto-negotiation capability. Before any auto-negotiation information is exchanged, or if the Link Partner does not comply with IEEE auto-negotiation, the bit returns a value of 0.

## Auto-Negotiation Next Page Register (Page A0h–B7h/Addr 0Eh–0Fh)

**Table 333: Next Page Transmit Register (Pages A0h–B7h, Address 0Eh–0Fh)**

Bit	Name	R/W	Description	Default
15	Next Page	R/W	<ul style="list-style-type: none"> <li>1 = Additional Next Page(s) follow.</li> <li>0 = Last page.</li> </ul>	0
14	Reserved	R/W	Ignore when Read.	0
13	Message Page	R/W	<ul style="list-style-type: none"> <li>1 = Message page.</li> <li>0 = Unformatted page.</li> </ul>	1
12	Acknowledge 2	R/W	<ul style="list-style-type: none"> <li>1 = Complies with the message.</li> <li>0 = Cannot comply with message.</li> </ul>	0
11	Toggle	RO	<ul style="list-style-type: none"> <li>1 = Previous value of the transmitted Link Code Word equalled logic 0.</li> <li>0 = Previous value of the transmitted Link Code Word equalled logic one.</li> </ul>	0
10:0	Message/Unformatted Code Field	R/W		1

### Next Page

Indicates whether this is the last Next Page to be transmitted.

### Message Page

Differentiates a Message Page from an Unformatted Page.

### Acknowledge 2

Indicates that a device has the ability to comply with the message.

### Toggle

Used by the Arbitration function to ensure synchronization with the Link Partner during Next Page exchange.

### Message Code Field

An 11-bit-wide field, encoding 2048 possible messages.

### Unformatted Code Field

An 11-bit-wide field, which may contain an arbitrary value.

## Link Partner Next Page Register (Page A0h–B7h/Addr 10h–11h)

**Table 334: Link Partner Next Page Register (Pages A0h–B7h, Address 10h–11h)**

Bit	Name	R/W	Description	Default
15	Next Page	RO	<ul style="list-style-type: none"> <li>1 = Additional Next Page(s) follow.</li> <li>0 = Last page.</li> </ul>	0
14	Reserved	RO	Ignore when Read.	0
13	Message Page	RO	<ul style="list-style-type: none"> <li>1 = Message page.</li> <li>0 = Unformatted page.</li> </ul>	0
12	Acknowledge 2	RO	<ul style="list-style-type: none"> <li>1 = Complies with the message.</li> <li>0 = Cannot comply with message.</li> </ul>	0
11	Toggle	RO	<ul style="list-style-type: none"> <li>1 = Previous value of the transmitted Link Code Word equalled logic 0.</li> <li>0 = Previous value of the transmitted Link Code Word equalled logic one.</li> </ul>	0
10:0	Message/Unformatted Code Field	RO	–	0

### Next Page

indicates whether this is the last Next Page.

### Message Page

Differentiates a Message Page from an Unformatted Page.

### Acknowledge 2

Indicates that Link Partner has the ability to comply with the message.

### Toggle

Used by the Arbitration function to ensure synchronization with the Link Partner during Next Page exchange.

### Message Code Field

An 11-bit-wide field, encoding 2048 possible messages.

### Unformatted Code Field

An 11-bit-wide field, which may contain an arbitrary value.



## Page D8h–DAh: External PHY Registers

Information on the External PHY registers should be obtained from the external PHY data sheet. Data is obtained by polling the registers of the external PHY via the “MDC/MDIO Interface” on page 114. The actual values or meanings of these bits are controlled by the external PHY. Table 335 maps the external PHY register address to the BCM53242M offset address.

**Table 335: External Port MII Registers Page Versus PHY**

Page	Port #	Hardware PHY address
D8h	48	11000
D9	49 (G0)	11001
DA	50 (G1)	11010

**Table 336: External PHY Registers (Page D8h-DAh)**

External PHY			
Register Address	Switch Address	bits	Description
00h	00h-01h	16	MII Control register
01h	02h-03h	16	MII Status register
02h	04h-07h	32	PHY Identifier registers
04h	08h–09h	16	Auto-negotiation Advertisement register
05h	0Ah–0Bh	16	Auto-negotiation Link Partner Ability register
06h	0Ch–0Dh	16	Auto-negotiation Expansion register
07h	0Eh–0Fh	16	Auto-negotiation Next Page register
08h	10h–11h	16	Link Partner Next Page register
09h–0Fh	12h–1Fh	Reserved	
10h	20h-21h	16	PHY specific register
11h	22h-23h	16	PHY specific register
12h	24h-25h	16	PHY specific register
13h	26h-27h	16	PHY specific register
14h	28h-29h	16	PHY specific register
15h	2Ah-2Bh	16	PHY specific register
16h	2Ch-2Dh	16	PHY specific register
17h	2Eh-2Fh	16	PHY specific register
18h	30h-31h	16	PHY specific register
19h	32h-33h	16	PHY specific register
1Ah	34h-35h	16	PHY specific register
1Bh	36h-37h	16	PHY specific register

**Table 336: External PHY Registers (Page D8h-DAh)**

<i>External PHY</i>			
<i>Register Address</i>	<i>Switch Address</i>	<i>bits</i>	<i>Description</i>
1Ch	38h-39h	16	PHY specific register
1Dh	3Ah-3Bh	16	PHY specific register
1Eh	3Ch-3Dh	16	PHY specific register
1Fh	3Eh-3Fh	16	PHY specific register

Broadcom Confidential

## Global Registers

**Table 337: Global Registers (Maps to All Pages)**

Address	Bits	Description
0xF0	8	0 "SPI Data I/O Register" on page 355
0xF1	8	1 "SPI Data I/O Register" on page 355
0xF2	8	2 "SPI Data I/O Register" on page 355
0xF3	8	3 "SPI Data I/O Register" on page 355
0xF4	8	4 "SPI Data I/O Register" on page 355
0xF5	8	5 "SPI Data I/O Register" on page 355
0xF6	8	6 "SPI Data I/O Register" on page 355
0xF7	8	7 "SPI Data I/O Register" on page 355
0xF8h–0xFD	Reserved	
0xFE	8	"SPI Status Register" on page 355
0xFF	8	"Page Register" on page 356

## SPI Data I/O Register

**Table 338: SPI Data I/O Register (Maps to All Registers, Address F0h–F7h)**

Bit	Name	R/W	Description	Default
7:0	SPI Data I/O	R/W	SPI data bytes[7:0]	–

## SPI Status Register

**Table 339: SPI Status Register (Maps to All Registers, Address FEh)**

Bit	Name	R/W	Description	Default
7	SPIF	RO	SPI Read/Write Complete Flag.	0
6	WCOL	RO	SPI Write Collision	0
5	RACK	RO (SC)	SPI Read Data Ready Acknowledgement (Self-Clearing).	0
4:3	Reserved	RO	Write as 000, ignore when read.	0
2	MDIO Start	RO	Start/Done MDC/MDIO operation	0
1	RXRDY	RO	Rx Ready Flag—Should check every 8 bytes.	0
0	TXRDY	RO	Tx Ready Flag—Should check every 8 bytes.	0

## Page Register

*Table 340: Page Register (Maps to All Registers, Address FFh)*

<i>Bit</i>	<i>Name</i>	<i>R/W</i>	<i>Description</i>	<i>Default</i>
7:0	PAGE_REG	R/W	Binary value determines the value of the accessed register page.	0

Broadcom Confidential

## Section 9: Electrical Characteristics

### Absolute Maximum Ratings

Table 341: Absolute Maximum Ratings

Symbol	Parameter	Minimum	Maximum	Units
V <sub>1.2</sub>	Supply Voltage	GND-0.3	1.32	V
V <sub>2.5</sub>	Supply Voltage	GND-0.3	2.75	V
V <sub>3.3</sub>	Supply Voltage	GND-0.3	3.63	V
I <sub>I</sub>	Input Current	–	±10	mA
T <sub>STG</sub>	Storage Temperature	–40	+125	°C
V <sub>ESD</sub>	Electrostatic Discharge	–	1000	V

**Note:** These specifications indicate conditions where permanent damage to the device may occur. Functional operation is not guaranteed under these conditions. Operation at absolute maximum conditions for extended periods may adversely affect the long-term reliability of the device.

### Recommended Operating Conditions

Table 342: Recommended Operating Conditions

Sym	Parameter	Pins	Mode	Minimum	Maximum	Units
VDD	Supply voltage (see Note)	VDDC, AVDDL	–	1.14	1.26	V
		VDDO2, BIASVDD, XTALVDD, VDDP	–	2.375	2.625	V
		VDDO0, VDDO1, VDDO3	–	3.135	3.465	V
V <sub>IH</sub>	High-level input voltage	All digital inputs	–	2.0	–	V
V <sub>IL</sub>	Low-level input voltage	All digital inputs	–	–	0.8	V
V <sub>IDIFF</sub>	Differential input voltage	RD±{0:23}	–	150	–	mV
CT	Magnetic center-tap	–	TX	2.375	2.625	V
V <sub>ICM</sub>	Common mode input voltage	RD±{0:23}	TX	2.375	2.625	V
			FX	1.14	2.625	V
R <sub>DAC</sub>	DAC current-setting resistance	RDAC	–	1.00	1.00	kΩ (1%)
T <sub>A</sub>	Ambient operating temperature	–	–	0	70	°C

**Table 342: Recommended Operating Conditions**

Sym	Parameter	Pins	Mode	Minimum	Maximum	Units
T <sub>A</sub>	Ambient operating temperature (Industrial Grade)	–	–	-40	85	°C
T <sub>J</sub>	Maximum Junction Temperature	–	–	–	125	°C

**Note:** VDD00, VDD01, VDD03 can be set to 2.5V depending the device configuration. See [Table 43: “Hardware Signal Definitions,” on page 132.](#)

**Note:** For Power-on sequence, it is recommended to power up 1.2V, 2.5V and 3.3V supplies as quickly as possible with a delay separation within 1 to 5 ms. The total ramp-up time should be maintained at less than 10 ms.

## Electrical Characteristics

**Table 343: Electrical Characteristics**

Sym	Parameter	Pins	Conditions	Minimum	Typical	Maximum	Units
I <sub>DD1.2</sub>	1.2V supply current	–	100Base-TX	–	–	1450	mA
			10Base-T (50 percent utilization)	–	–	992	
			10Base-T (100 percent utilization)	–	–	977	
I <sub>DD2.5</sub>	2.5V supply current	–	10Base-T/ 100Base-TX	–	–	193	mA
I <sub>DD1.8</sub>	Total supply for front end current	Transformer center taps, termination resistors	100Base-TX	–	–	1120	mA
			10Base-T (50 percent utilization)	–	–	960	
			10Base-T (100 percent utilization)	–	–	1699	
I <sub>DD2.5</sub>	Total supply for front-end current	Transformer center taps, termination resistors	100Base-TX	–	–	1159	mA
			10Base-T (50 percent utilization)	–	–	1050	
			10Base-T (100 percent utilization)	–	–	1869	
I <sub>DD3.3</sub>	3.3V supply current*	–	–	–	–	100	mA
V <sub>OH</sub>	High-level output voltage	Digital output	I <sub>OH</sub> = –4/8/15 mA	2.0	–	–	V
		TD± {47:24}	Driving loaded magnetics module	–	–	VDD + 1.5	V

**Table 343: Electrical Characteristics**

<b>Sym</b>	<b>Parameter</b>	<b>Pins</b>	<b>Conditions</b>	<b>Minimum</b>	<b>Typical</b>	<b>Maximum</b>	<b>Units</b>
V <sub>OL</sub>	Low-level output voltage	Digital output	I <sub>OL</sub> = 4/8/15 mA	–	–	0.4	V
		TD± {47:24}	Driving loaded magnetics module	VDD – 1.5	–	–	V
I <sub>I</sub>	Input current	Digital inputs with pull-up resistors	V <sub>I</sub> = VDDO	–	–	+100	μA
			V <sub>I</sub> = GND	–	–	–200	μA
		Digital inputs with pull-down resistors	V <sub>I</sub> = VDDO	–	–	+200	μA
			V <sub>I</sub> = GND	–	–	–10	μA
All other digital inputs	GND ≤ V <sub>I</sub> ≤ VDDO	–	–	±100	μA		
I <sub>OZ</sub>	High-impedance output current	All three-state outputs	GND ≤ V <sub>O</sub> ≤ VDDO	–	–	±10	μA
		All open-drain outputs	V <sub>O</sub> = VDDO	–	–	+10	μA

\* = Per GMII interface.

# Section 10: BCM53242M Timing Characteristics

## Reset and Clock Timing

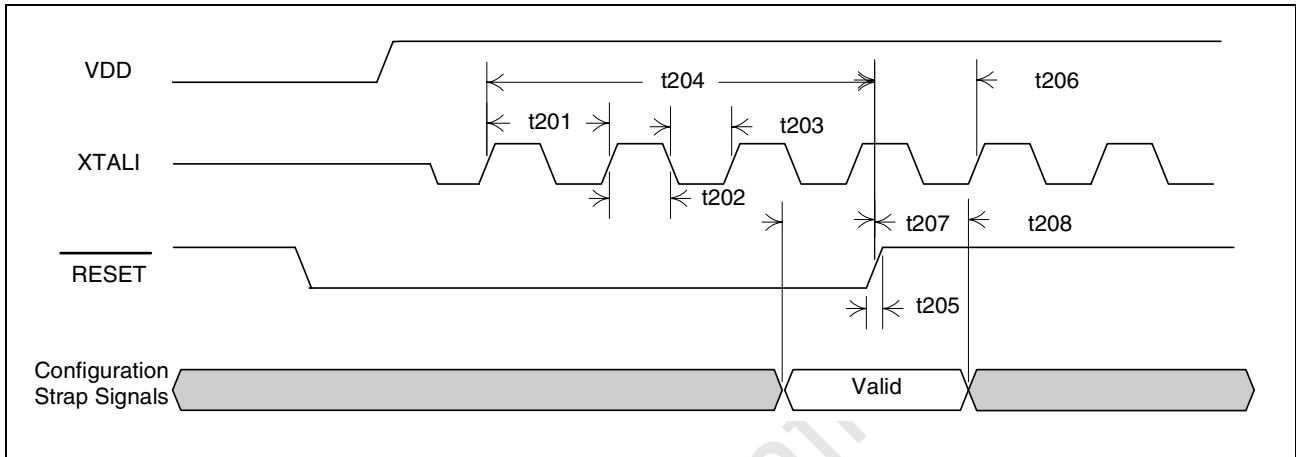

Figure 42: Reset and Clock Timing

Table 344: Reset and Clock Timing

Parameter	Description	Minimum	Typical	Maximum
t201	XTALI Period	39.998 ns	40 ns	40.002 ns
t202	XTALI High Time	18 ns	–	22 ns
t203	XTALI Low Time	18 ns	–	22 ns
t204	RESET Low Pulse Duration	400 ns	50 ms	–
t207	Configuration Valid Setup to RESET Rising	100 ns	–	–
t208	Configuration Valid Hold from RESET Rising	–	–	0 ns



# LED Timing

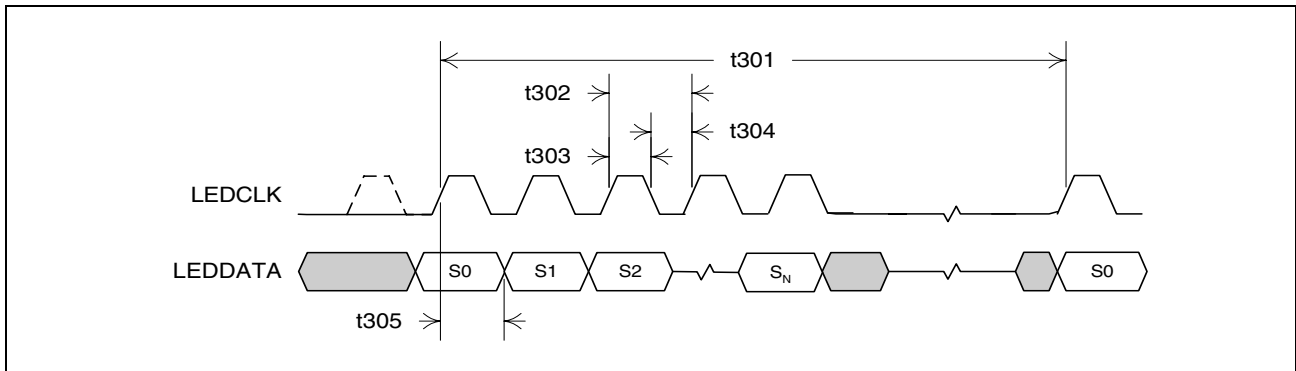

Figure 43: Serial LED Timing

Table 345: Serial LED Timing

Parameter	Description	Minimum	Typical	Maximum
t301	LED UPDATE CYCLE PERIOD	–	40 ms	–
t302	LEDCLK PERIOD	–	320 ns	–
t303	LEDCLK High Pulse Width	150 ns	–	170 ns
t304	LEDCLK Low Pulse Width	150 ns	–	170 ns
t305	LEDCLK to LEDDATA Output Time	140 ns	–	180 ns

## MII Input Timing

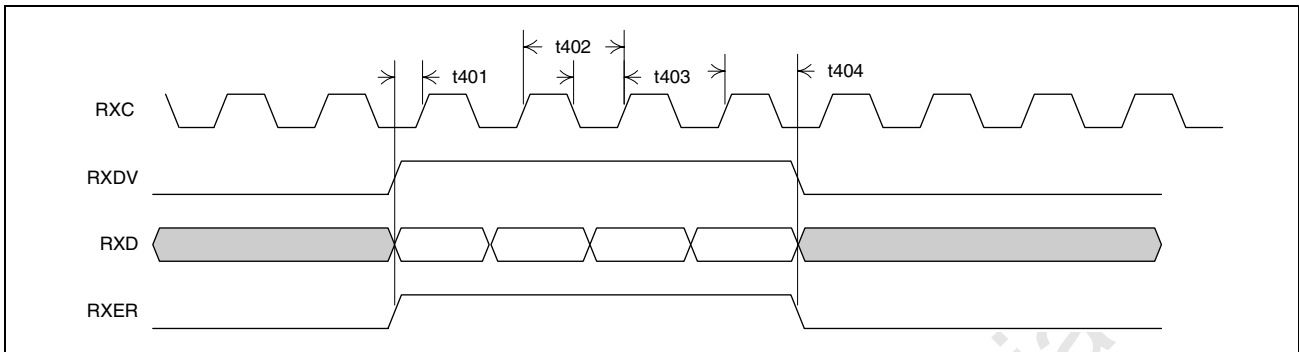

Figure 44: MII Input Timing

Table 346: MII Input Timing

Parameter	Description	Minimum	Typical	Maximum
t401	RXDV, RXD, RXER, to RXC Rising Setup Time	5 ns	–	–
t402	RXC Clock Period (10Base-T mode)	–	400 ns	–
	RXC Clock Period (100Base-T mode)	–	40 ns	–
t403	RXC High/Low Time (10Base-T mode)	160 ns	–	240 ns
	RXC High/Low Time (100Base-T mode)	14 ns	–	26 ns
t404	RXDV, RXD, RXER, to RXC Rising Hold Time	5 ns	–	–

## RvMII Input Timing

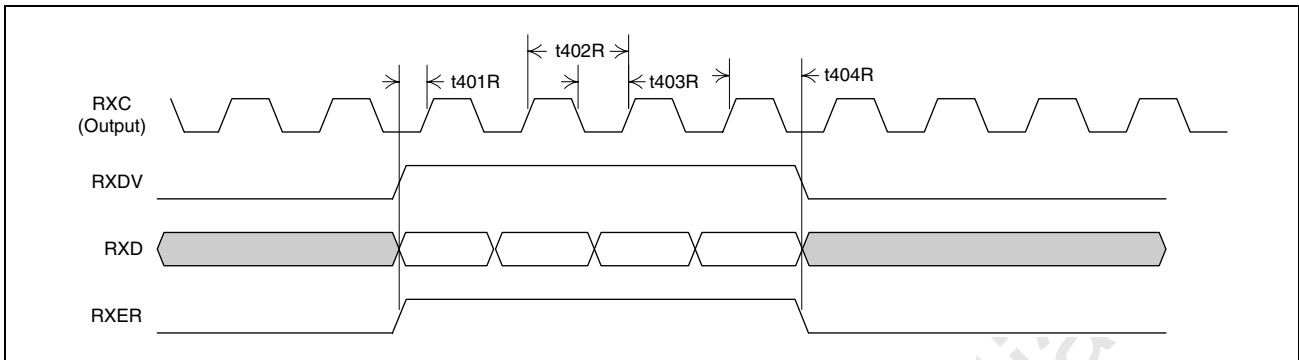

Figure 45: RvMII Input Timing

Table 347: RvMII Input Timing

Parameter	Description	Minimum	Typical	Maximum
t401R	RXDV, RXD, RXER, to RXC Rising Setup Time	10 ns	–	–
t402R	RXC Clock Period (100Base-T mode only)	–	40 ns	–
t403R	RXC High/Low Time (100Base-T mode only)	14 ns	–	26 ns
t404R	RXDV, RXD, RXER, to RXC Rising Hold Time	0 ns	–	–

## MII Output Timing

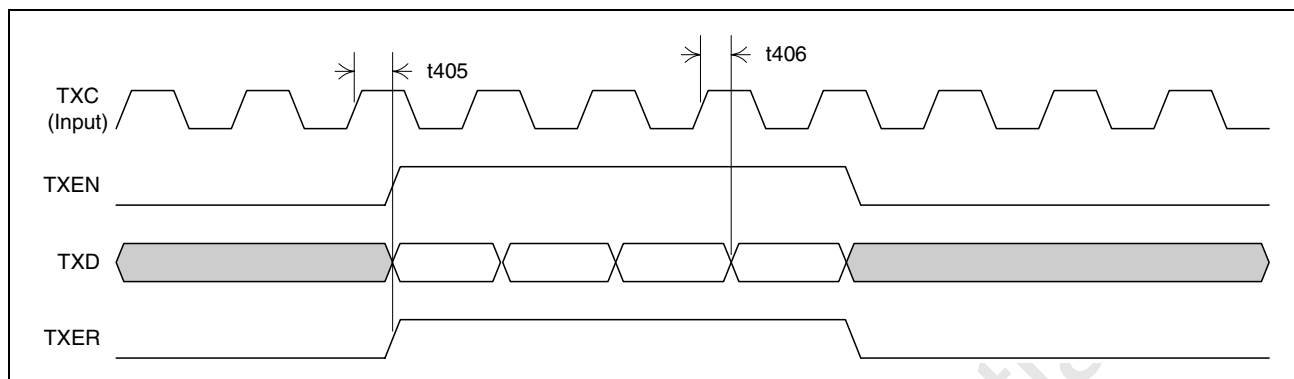

Figure 46: MII Output Timing

Table 348: MII Output Timing

Parameter	Description	Minimum	Typical	Maximum
t405	TXC High to TXEN, TXD, TXER Valid	–	–	22 ns
t406	TXC High to TXEN, TXD, TXER Invalid	3 ns	–	–

## RvMII Output Timing

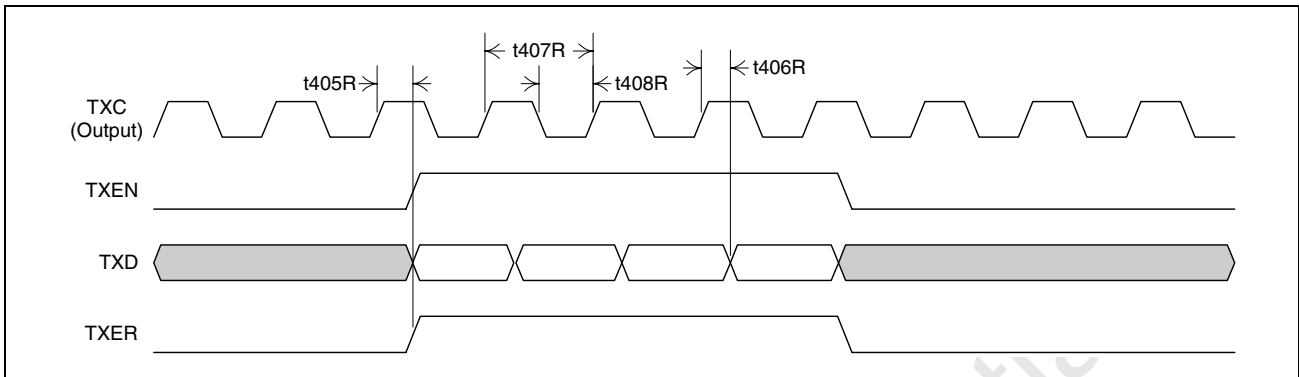

Figure 47: RvMII Output Timing

Table 349: RvMII Output Timing

Parameter	Description	Minimum	Typical	Maximum
t405R	TXC High to TXEN, TXD, TXER Valid	–	–	29 ns
t406R	TXC High to TXEN, TXD, TXER Invalid	11 ns	–	–
t407R	TXC Clock Period	–	40 ns	–
t408R	TXC High/Low Time	14 ns	–	26 ns

# RGMII Interface Timing

## RGMII Output Timing (Normal Mode)

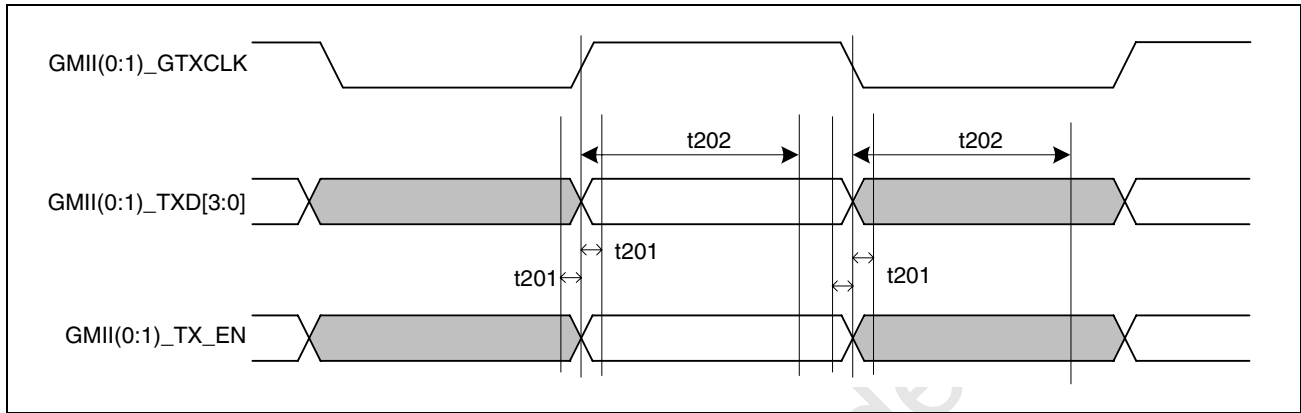

Figure 48: RGMII Output Timing (Normal Mode)

Table 350: RGMII Output Timing (Normal Mode)

Description	Parameter	Minimum	Typical	Maximum	Unit
TXCLK clock period (1000M mode)	–	7.2	8	8.8	ns
TXCLK clock period (100M mode)	–	36	40	44	ns
TXCLK clock period (10M mode)	–	360	400	440	ns
Data valid to clock transition: Available setup time at the output source	t201	–500 (1000M)	–	+500 (1000M)	ps
Clock transition to data valid: Available hold time at the output source	t202	3.1	–	–	ns

## RGMI Output Timing (Delayed Mode Clock)

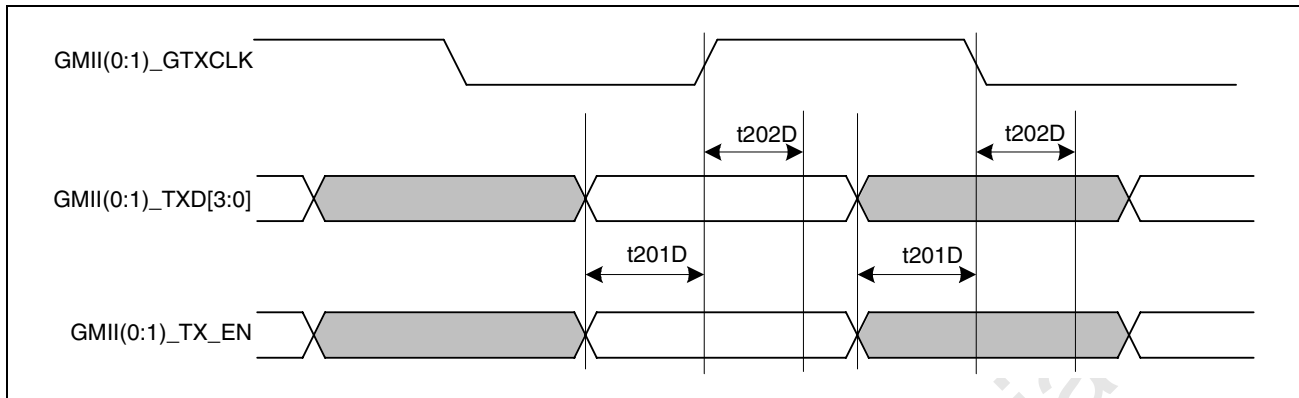

Figure 49: RGMI Output Timing (Delayed Mode Clock)

Table 351: RGMI Output Timing (Delayed Mode Clock)

Description	Parameter	Minimum	Typical	Maximum	Unit
TXCLK clock period (1000M mode)	–	7.2	8	8.8	ns
TXCLK clock period (100M mode)	–	36	40	44	ns
TXCLK clock period (10M mode)	–	360	400	440	ns
Data valid to clock transition: Available setup time at the output source (delayed mode clock)	t201D	1.2 (all speeds)	–	–	ns
Clock transition to data valid: Available hold time at the output source (delayed mode clock)	t202D	1.2	–	–	ns

## RGMII Input Timing (Normal Mode)

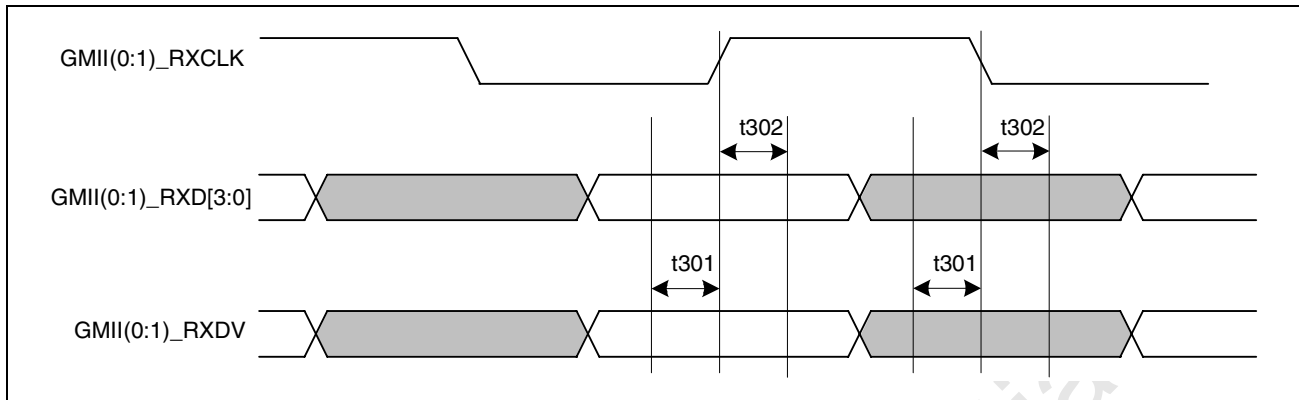

Figure 50: RGMII Input Timing (Normal Mode)

Table 352: RGMII Input Timing (Normal Mode)

Description	Parameter	Minimum	Typical	Maximum	Unit
TXCLK clock period (1000M mode)	–	7.2	8	8.8	ns
TXCLK clock period (100M mode)	–	36	40	44	ns
TXCLK clock period (10M mode)	–	360	400	440	ns
Input setup time	t301	1.0 (all speeds)	–	–	ns
Input hold time	t302	1.0 (all speeds)	–	–	ns
Required data window at the input	t301+t302	2.0	–	–	ns



## RGMI Input Timing (Delayed Mode Clock)

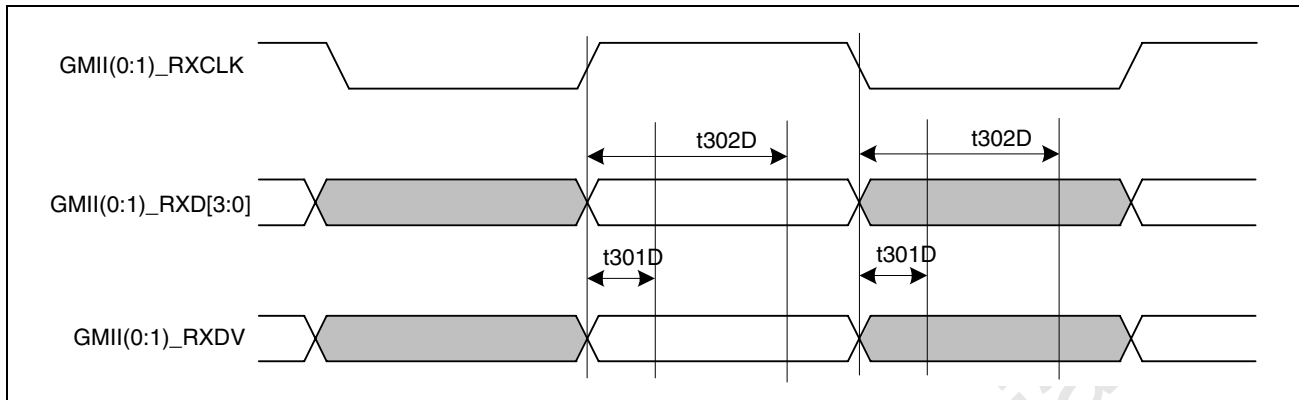

Figure 51: RGMI Input Timing (Delayed Mode Clock)

Table 353: RGMI Input Timing (Delayed Mode Clock)

Description	Parameter	Minimum	Typical	Maximum	Unit
TXCLK clock period (1000M mode)	–	7.2	8	8.8	ns
TXCLK clock period (100M mode)	–	36	40	44	ns
TXCLK clock period (10M mode)	–	360	400	440	ns
Input setup time (delayed mode clock)	t301D	–1.0 (1000M)	–	–	ns
		–5.0 (10/100M)	–	–	ns
Input hold time (delayed mode clock)	t302D	3.0 (1000M)	–	–	ns
		7.0 (10/100M)	–	–	ns
Required data window at the input	t301D+t302D	2.0	–	–	ns

# GMII Interface Timing

## GMII Interface Output Timing

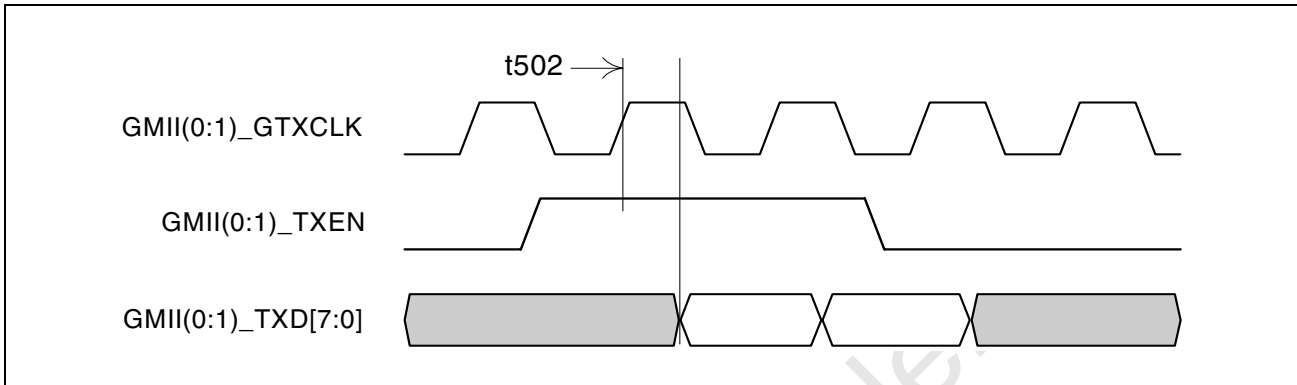

Figure 52: GMII Output Timing

Table 354: GMII Output Timing

Description	Parameter	Minimum	Typical	Maximum	Unit
GMII(0:1)_GTXCLK clock period (1000M mode)	–	–	8	–	ns
GMII(0:1)_GTXCLK clock period (100M mode)	–	–	40	–	ns
GMII(0:1)_GTXCLK clock period (10M mode)	–	–	400	–	ns
Output delay from GMII(0:1)_GTXCLK rising	$t_{502}$	0.5	–	5.5	ns

## GMII Interface Input Timing

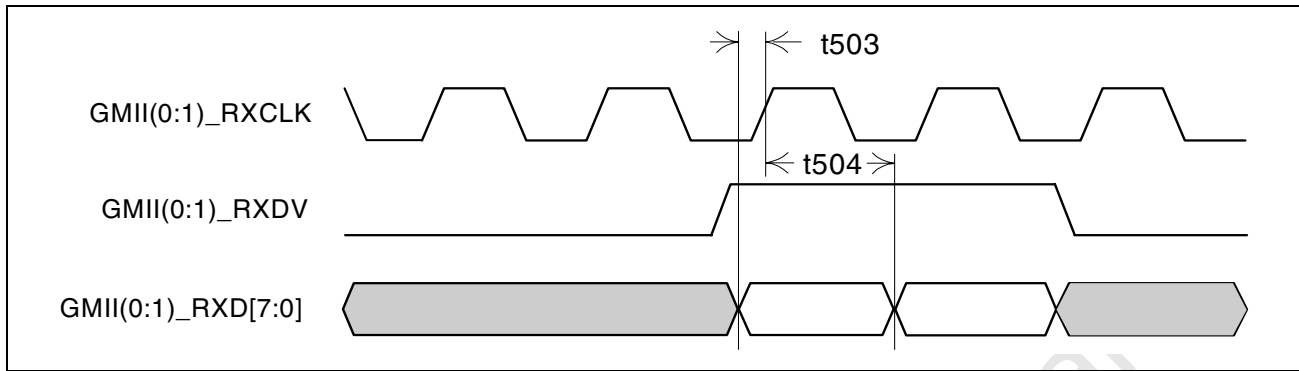

Figure 53: GMII Input Timing

Table 355: GMII Input Timing

Description	Parameter	Minimum	Typical	Maximum	Unit
GMII(0:1)_RXCLK clock period (1000M mode)	–	–	8	–	ns
GMII(0:1)_RXCLK clock period (100M mode)	–	–	40	–	ns
GMII(0:1)_RXCLK clock period (10M mode)	–	–	400	–	ns
Input setup time	t503	2.0	–	–	ns
Input hold time	t504	0.0	–	–	ns

# TBI Interface Timing

## TBI Interface Output Timing

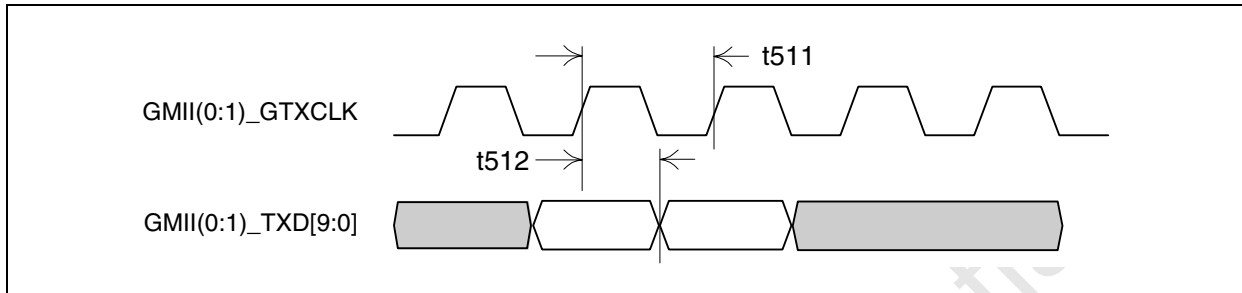

Figure 54: TBI Output Timing

Table 356: TBI Output Timing

Description	Parameter	Minimum	Typical	Maximum	Unit
GMII(0:1)_GXTCLK clock period	t511	–	8	–	ns
Output delay from GMII(0:1)_GXTCLK rising	t512	1.5	–	5.5	ns

## TBI Interface Input Timing

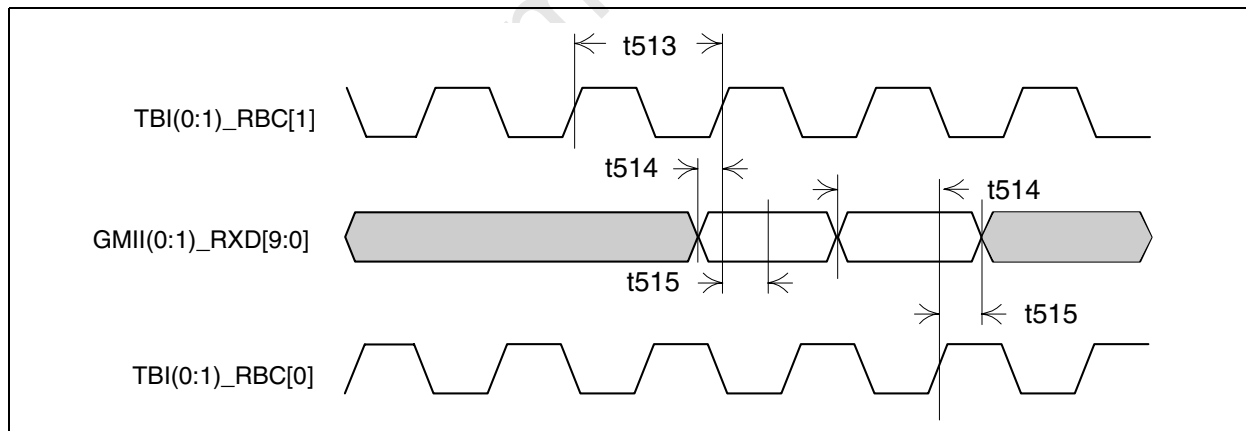

Figure 55: TBI Input Timing

Table 357: TBI Input Timing

Description	Parameter	Minimum	Typical	Maximum	Unit
TBI(0:1)_RBC Frequency	t513	–	62.5	–	MHz

**Table 357: TBI Input Timing**

<b>Description</b>	<b>Parameter</b>	<b>Minimum</b>	<b>Typical</b>	<b>Maximum</b>	<b>Unit</b>
Input setup time	t514	2.5	–	–	ns
Input hold time	t515	1.5	–	–	ns

Broadcom Confidential

# SPI Timing

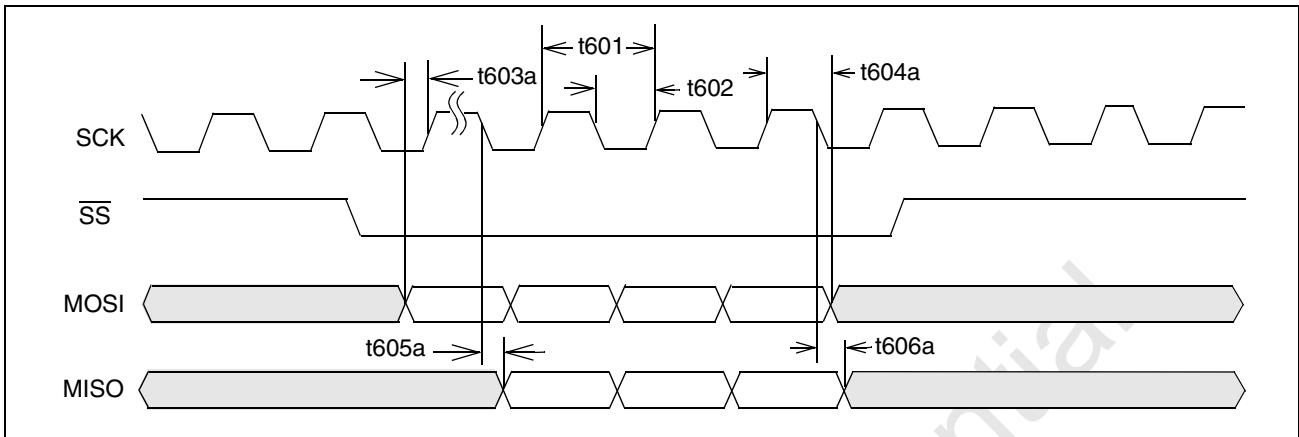

Figure 56: SPI Timing,  $\overline{SS}$  Asserted During SCK High

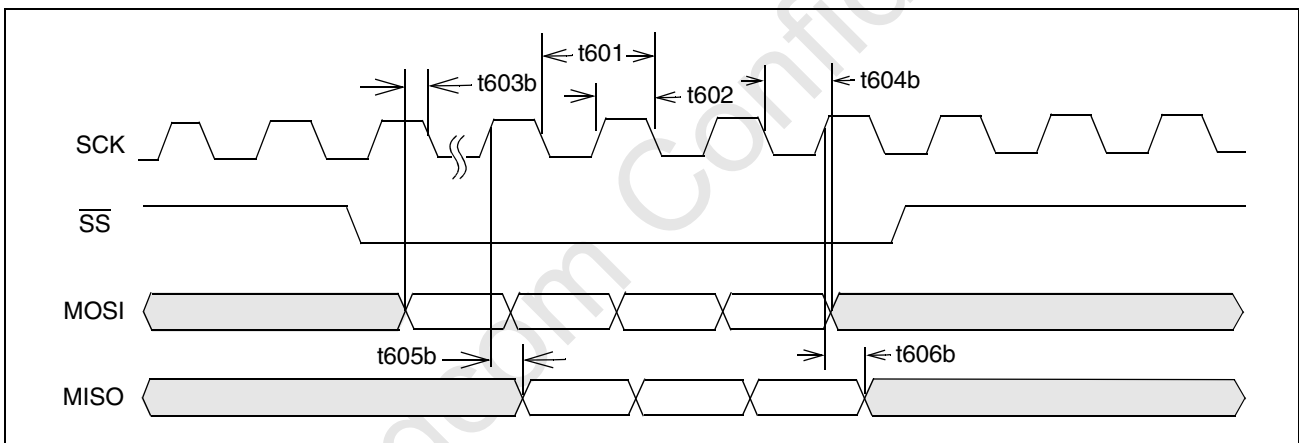

Figure 57: SPI Timing,  $\overline{SS}$  Asserted During SCK Low

Table 358: SPI Timing

Parameter	Description	Minimum	Typical	Maximum
t601	SCK Clock Period	–	500 ns	–
t602	SCK High/Low Time	200 ns	–	300 ns
t603a, t603b	MOSI to SCK Setup Time	5 ns	–	–
t604a, t604b	MOSI to SCK Hold Time	12 ns	–	–
t605a, t605b	SCK to MISO Valid	–	–	25 ns
t606a, t606b	SCK to MISO Invalid	0 ns	–	–



**Note:** The BCM53242M behaves only as a slave device. The  $\overline{SS}$  is asynchronous. If  $\overline{SS}$  is asserted during SCK high then BCM53242M samples data on the rising edge of SCK and references the falling edge to output data. Otherwise BCM53242M samples data on the falling edge and outputs data on the rising edge of SCK.

Broadcom Confidential

## EEPROM Timing

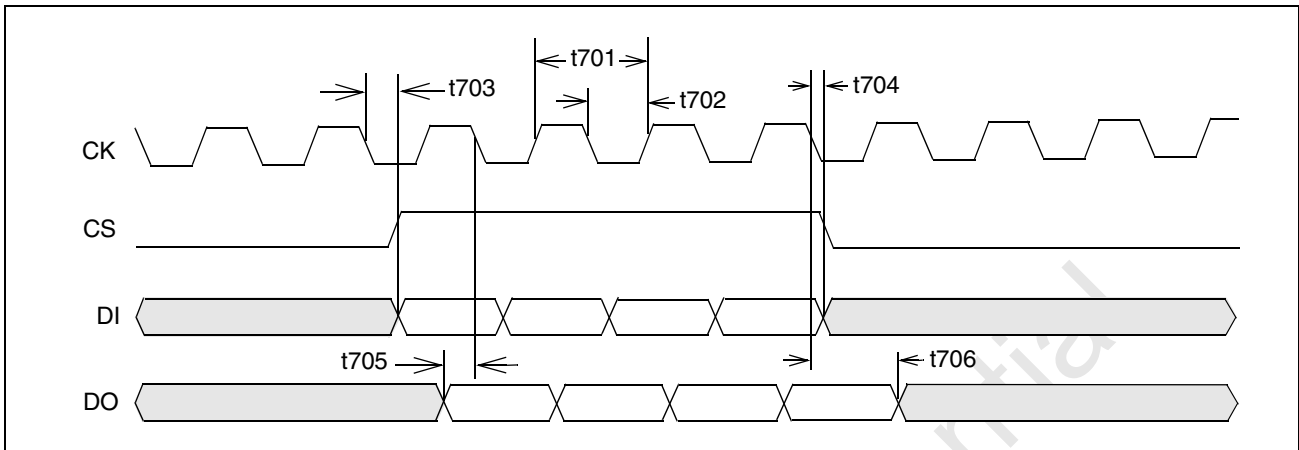

Figure 58: EEPROM Timing

Table 359: EEPROM Timing

Parameter	Description	Minimum	Typical	Maximum
t701	CK Clock Frequency	–	100 KHz	–
t702	CK High/Low Time	–	5 us	–
t703	CK low to CS, DI Valid	–	–	500 ns
t704	CK low to CS, DI Invalid	500 ns	–	–
t705	DO to CK falling Setup Time	200 ns	–	–
t706	DO to CK falling Hold Time	200 ns	–	–

## Management Data Interface

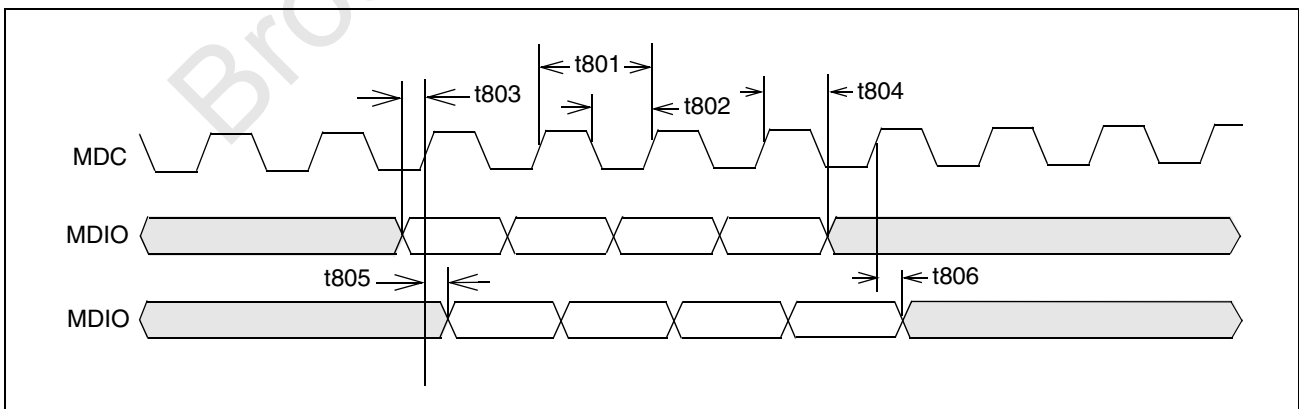

Figure 59: Management Data Interface



**Table 360: Management Data Interface (Slave Mode)**

<b>Parameter</b>	<b>Description</b>	<b>Minimum</b>	<b>Typical</b>	<b>Maximum</b>
t801	MDC Clock Period	–	80 ns	–
t802	MDC High/Low Time	30 ns	–	50 ns
t803	MDIO to MDC rising Setup Time	5 ns	–	–
t804	MDIO to MDC rising Hold Time	5 ns	–	–
t805	MDC rising to MDIO Valid	–	–	50 ns
t806	MDC rising to MDIO Invalid	10 ns	–	–

**Table 361: Management Data Interface (Master Mode)**

<b>Parameter</b>	<b>Description</b>	<b>Minimum</b>	<b>Typical</b>	<b>Maximum</b>
t801	MDC Clock Period	–	400 ns	–
t802	MDC High/Low Time	150 ns	–	250 ns
t803	MDIO to MDC rising Setup Time	10 ns	–	–
t804	MDIO to MDC rising Hold Time	10 ns	–	–
t805	MDC rising to MDIO Valid	–	–	100 ns
t806	MDC rising to MDIO Invalid	10 ns	–	–

## Section 11: Thermal Characteristics

**Table 362: 400-PBGA Thermal Characteristics with External Heat Sink at 70°C**

<b>Air Flow (LFPM)</b>	<b>0</b>	<b>100</b>	<b>200</b>	<b>400</b>	<b>600</b>
Theta-JA (°C/W)	10.43	8.20	7.42	6.80	6.58
Theta-JB (°C/W)	5.26	–	–	–	–
Theta-JC (°C/W)	4.50	–	–	–	–
Maximum Junction Temperature T <sub>J</sub>	127.38°C	115.12	110.82	107.41	106.19
Heatsink: TwinPeaks Electronics Aluminum blade-fin, 35 mm x 35 mm x 20 mm, k = 180 W/m.K.					

**Table 363: 400-PBGA Thermal Characteristics with External Heat Sink at 85°C**

<b>Air Flow (LFPM)</b>	<b>0</b>	<b>100</b>	<b>200</b>	<b>400</b>	<b>600</b>
Theta-JA (°C/W)	10.43	8.20	7.42	6.80	6.58
Theta-JB (°C/W)	5.26	–	–	–	–
Theta-JC (°C/W)	4.50	–	–	–	–
Maximum Junction Temperature T <sub>J</sub>	142.38	130.12	125.82	122.41	121.19
Heatsink: TwinPeaks Electronics Aluminum blade-fin, 35 mm x 35 mm x 20 mm, k = 180 W/m.K.					

## Section 12: Mechanical Information

Broadcom Confidential

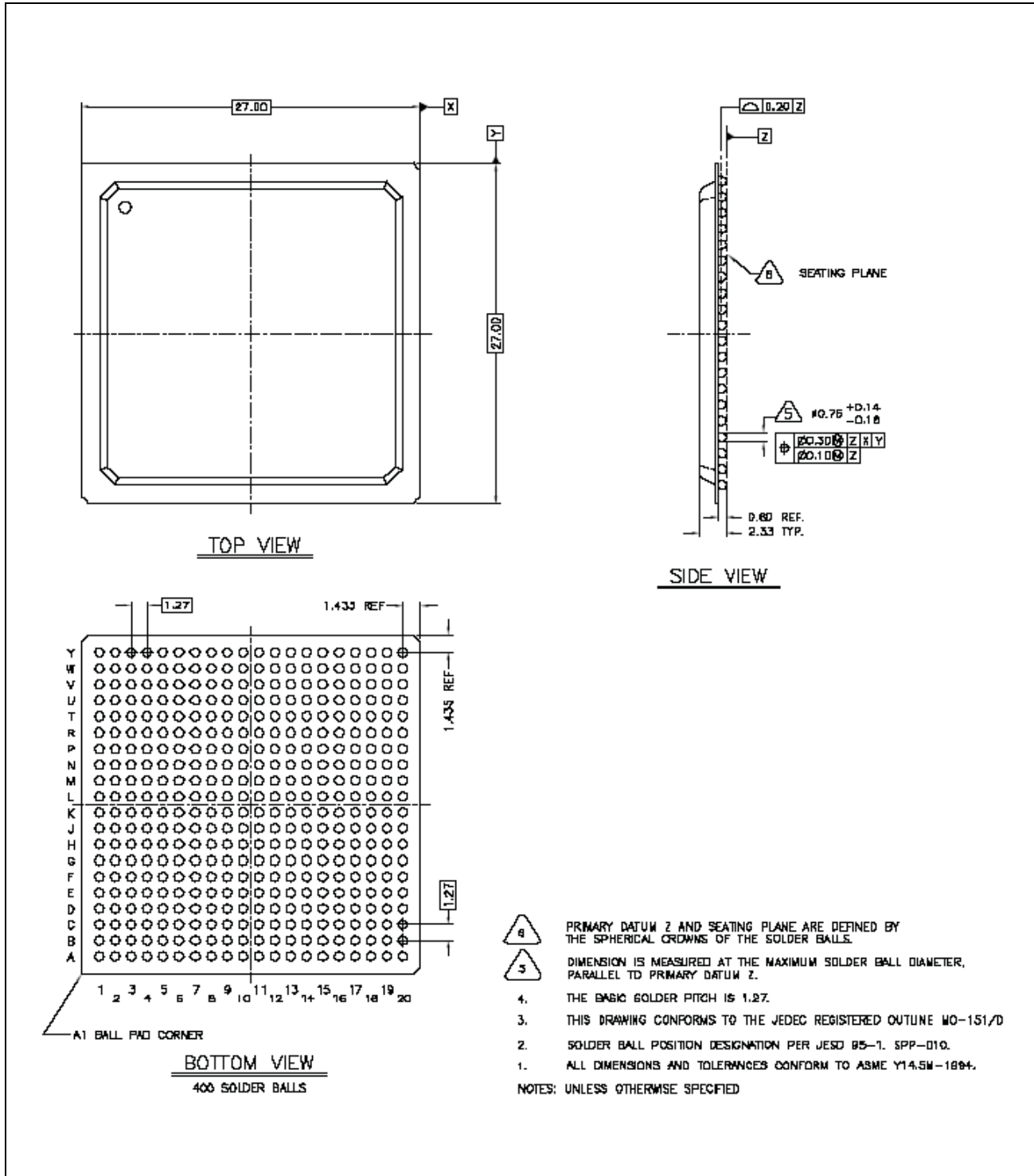

Figure 60: 400-PBGA Package Outline Drawing

## Section 13: Ordering Information

*Table 364: Ordering Information*

<i>Part Number</i>	<i>Package</i>	<i>Ambient Temperature</i>
BCM53242MKPB(G)	400 PBGA	Commercial grade 0°C to 70°C
BCM53242MIPB(G)	400 PBGA	Industrial grade –40°C to 85°C

**Note:** The letter *G* denotes the lead-free option.

Broadcom Confidential

Broadcom Confidential

Broadcom® Corporation reserves the right to make changes without further notice to any products or data herein to improve reliability, function, or design.

Information furnished by Broadcom Corporation is believed to be accurate and reliable. However, Broadcom Corporation does not assume any liability arising out of the application or use of this information, nor the application or use of any product or circuit described herein, neither does it convey any license under its patent rights nor the rights of others.

Connecting  
everything®



**BROADCOM CORPORATION**

5300 California Avenue

Irvine, CA 92617

© 2011 by BROADCOM CORPORATION. All rights reserved.

Phone: 949-926-5000

Fax: 949-926-5203

E-mail: [info@broadcom.com](mailto:info@broadcom.com)

Web: [www.broadcom.com](http://www.broadcom.com)

## X-ON Electronics

Largest Supplier of Electrical and Electronic Components

*Click to view similar products for [Ethernet ICs](#) category:*

*Click to view products by [Broadcom](#) manufacturer:*

Other Similar products are found below :

[EZFM6324A S LKA5](#) [EZFM6364A S LKA7](#) [12200BS23MM](#) [EZFM5224A S LKA3](#) [VSC8522XJQ-02](#) [WGI219LM SLKJ3](#) [EZFM6348A S LKA6](#) [WGI219V SLKJ5](#) [BCM84793A1KFSBG](#) [BCM56680B1KFSBLG](#) [BCM53402A0KFSBG](#) [BCM56960B1KFSBG](#) [EZX557AT2 S LKVX](#) [BCM56842A1KFTBG](#) [BCM56450B1KFSBG](#) [EZX557AT S LKW4](#) [LAN9254-I/JRX](#) [RTL8211FS-CG](#) [RTL8153-VC-CG](#) [CH395L](#) [KTI225IT S LNNK](#) [KTI225IT S LNNL](#) [VSC8562XKS-14](#) [BCM56864A1IFSBG](#) [KSZ8462FHLLI](#) [LAN9303MI-AKZE](#) [KSZ8841-16MVLI](#) [KSZ8842-16MVLI](#) [KSZ8893MQL](#) [VSC8244XHG](#) [ADIN2111BCPZ](#) [ADIN2111CCPZ-R7](#) [FIDO2100BGA128IR0](#) [FIDO5210CBCZ](#) [FIDO5210BBCZ](#) [FIDO5110CBCZ](#) [FIDO5200CBCZ](#) [ADIN1110BCPZ](#) [ADIN1110CCPZ](#) [ADIN1100BCPZ](#) [ADIN1110CCPZ-R7](#) [ADIN1100CCPZ-R7](#) [ADIN1110BCPZ-R7](#) [DM9000EP](#) [DM9161AEP](#) [HG82567LM S LAVY](#) [LAN9210-ABZJ](#) [LAN9221-ABZJ](#) [LAN9221I-ABZJ](#) [LAN9211-ABZJ](#)