



10/100/1000BASE-T GIGABIT COPPER TRANSCEIVER

FEATURES

- Fully integrated 10BASE-T/100BASE-TX/1000BASE-T Gigabit Ethernet (GbE) transceiver
- RGMII MAC interface options
- On-chip low-voltage regulator
- Fully compliant with IEEE 802.3™, 802.3u, and 802.3ab standards
- 65-nm CMOS—low power and cost
- Low power
 - Less than 500 mW per port
 - Advanced power management
- Trace matched output impedance
- Line-side loopback
- Low electromagnetic interference (EMI) emissions
- Cable-plant diagnostics
 - Cable plant analyzer function detects cable plant impairments
 - Link quality indication LED
 - Automatic detection and correction of wiring pair swaps, pair skew, and pair polarity
 - Automatic MDI/MDIX crossover at all speeds
- Robust CESD tolerance
- Support for jumbo packets up to 10 KB
- IEEE 1149.1 (JTAG) boundary scan
- 48-pin MLP and 100-pin FBGA packages

SUMMARY OF BENEFITS

- Simplifies system and board design
 - Reduced I/O pin requirements with RGMII
 - On-chip RGMII timing delay
- Provides interoperability with IEEE standard devices operating at 10 Mbps, 100 Mbps, and 1000 Mbps at half- and full-duplex
- Lowers system bill of materials (BOM) cost and simplifies system design
- Requires no airflow or heatsink
- Eases system-level debug
- Reduces system design constraints to meet EMI emissions standards
- Cable diagnostic function characterizes cable plant condition and immediately indicates cabling issues
 - Prevents erroneous equipment return due to bad cable plants
 - Prevents manufacturing fallout due to bad cable plants
- High CESD tolerance prevents equipment damage and return
- Operates with larger packets for wider range of packet protocol support and improved efficiency
- Ease of manufacturing with JTAG support, simplified power supply, and multiple MAC interfaces

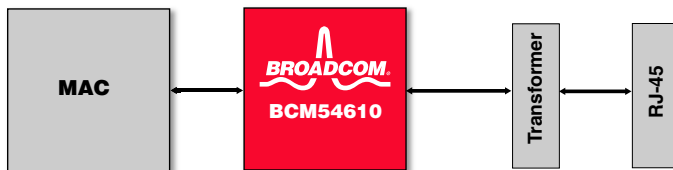

General Gigabit Ethernet Connectivity

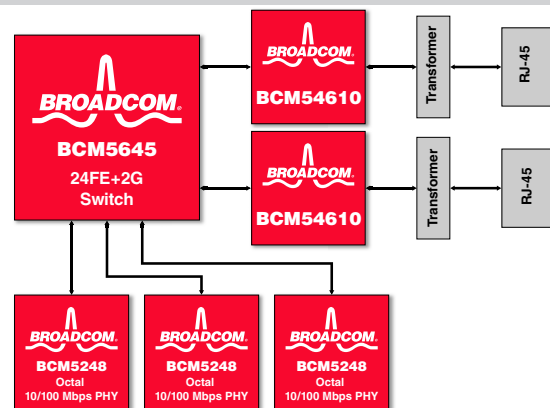

1000BASE-T Gigabit Uplink

OVERVIEW

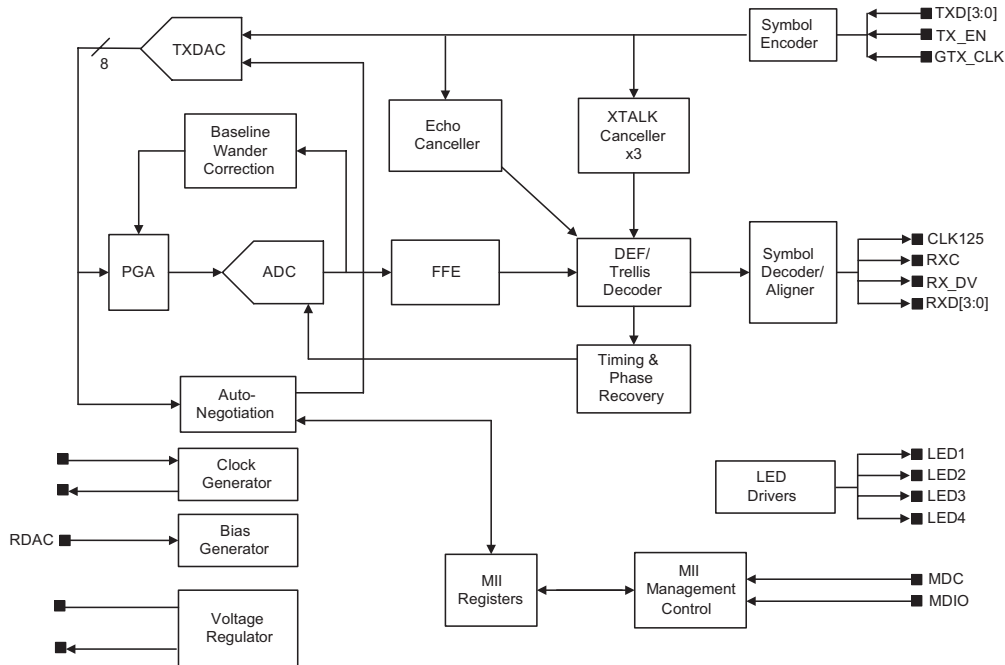

BCM54610 Reference Design

The BCM54610 is optimized for low power and small footprint size to enable uplink and general GbE connectivity applications. By lowering system cost and reducing power dissipation, the BCM54610 enables a new class of cost-effective GbE equipment, driving the delivery of Gigabit bandwidth to the desktop.

The BCM54610 digital signal processor-based architecture and advanced power management techniques combine to achieve robust and low power operation over the existing CAT-5 twisted-pair wiring. The BCM54610 architecture also meets the requirements of 802.3, 802.3u, and 802.3ab, but maintains the industry's highest level of margin over IEEE requirements for Echo, NEXT, and FEXT. Low power is a key factor in implementing Gigabit small form factor NICs and uplinks, and, at less than 500 mW per port, the BCM54610 has the industry's lowest power. Additionally, the BCM54610 has extremely low EMI emissions, which reduces the design constraints required to meet EMI emissions specifications.

The BCM54610 supports the IEEE 802.3 standard Reduced Gigabit Media Independent Interface (RGMII). RGMII is a reduced pin-count (12 versus 25) version of the Gigabit Media Independent Interface (GMII). The small package, multiple MAC interfaces, and streamlined power supply lower system cost and simplify the system and board level design.

This device is another member of the Broadcom 65-nm Gigabit copper PHY family, joining the BCM54680. The optimal 65-nm process offers the best performance, lowest cost, and lowest power for Gigabit copper solutions. Further, devices based on the 65-nm process offer an excellent long-term cost curve, enabling better cost reduction over time compared to older technologies, without having to redesign or requalify a new part.

The BCM54610 incorporates a variety of advanced features. The link quality indicator LED provides installers with immediate visual notification of any problems with the wiring plant supporting operation at the desired speed. This includes physical wiring defects that the BCM54610 cannot automatically correct and channel conditions such as excessive cable length and return loss, crosstalk, echo, and noise. Broadcom cable analyzer software can be used with the device to provide remote management of the cable and first-level diagnostics and fault isolation.

The BCM54610 also has ESD tolerance that exceeds typical industry standards. This feature not only prevents ESD damage during manufacturing but also during cable-sourced electrostatic discharge (CESD) events in the field. CESD is an ESD event that occurs when an electrically charged network cable is plugged into a network port, an issue becoming more prevalent with contemporary cable installations.

Broadcom®, the pulse logo, Connecting everything®, and the Connecting everything logo are among the trademarks of Broadcom Corporation and/or its affiliates in the United States, certain other countries and/or the EU. Any other trademarks or trade names mentioned are the property of their respective owners.

Connecting
everything®



BROADCOM CORPORATION

5300 California Avenue,
Irvine, California 92617

© 2008 by BROADCOM CORPORATION. All rights reserved.

54610-PB00-R 01/16/08

Phone: 949-926-5000

Fax: 949-926-5203

E-mail: info@broadcom.com

Web: www.broadcom.com

X-ON Electronics

Largest Supplier of Electrical and Electronic Components

Click to view similar products for [LIN Transceivers](#) category:

Click to view products by [Broadcom](#) manufacturer:

Other Similar products are found below :

[MC33911BAC](#) [MLX80004KLW-BAA-001-SP](#) [MCP2021T-500E/MD](#) [MCP2021-500E/P](#) [MCP2022P-330E/SL](#) [TLE8457DLEXUMA1](#)
[MCP2022-330E/SL](#) [MCP2022-500ESL](#) [NCV7420D26R2G](#) [TJA1027T/20/1J](#) [TJA1027T/20,118](#) [TJA1021T/20/CM,118](#) [MCP2003A-E/P](#)
[MCP2003A-E/SN](#) [MCP2003-E/P](#) [MCP2004A-E/P](#) [MCP2004A-E/SN](#) [MCP2004-E/MD](#) [MCP2004-E/P](#) [MCP2004-E/SN](#) [MCP2021-330E/MD](#)
[MCP2021-330E/P](#) [MCP2021-330E/SN](#) [MCP2021-500E/SN](#) [MCP2021A-330E/MD](#) [MCP2021A-330E/SN](#) [MCP2021A-500E/SN](#) [MCP2022-](#)
[500E/P](#) [MCP2022A-330E/SL](#) [MCP2022A-500E/SL](#) [MCP2025-330E/MD](#) [MCP2025-330E/P](#) [MCP2025-330E/SN](#) [MCP2025-500E/P](#)
[MCP2025-500E/SN](#) [MCP2050-330E/SL](#) [MCP2022A-330E/ST](#) [MCP2022A-500E/ST](#) [MC33662LEF](#) [MCP2003B-E/SN](#) [MCP2021T-500ESN](#)
[MAX13021ASA+](#) [MCP2003BT-E/MC](#) [TJA1020T/CM.118](#) [TJA1021T/20/C.118](#) [STLD1TR](#) [TLIN1022DMTTQ1](#) [TLIN14415DMTTQ1](#)
[TLIN2022DMTRQ1](#) [TPIC1021D](#)