



## QUAD-PORT GIGABIT COPPER TRANSCEIVER WITH COPPER/FIBER MEDIA INTERFACE

### FEATURES

- Four fully integrated 10BASE-T/100BASE-TX/1000BASE-T Gigabit Ethernet transceivers
- GMII, RGMII, SGMII, and SerDes MAC interface options
- Copper or SerDes line interface options
- Fully compliant with IEEE 802.3, 802.3u, and 802.3ab standards
- 0.13-micron CMOS—low-power and cost
- Low-power
  - 750 mW per port
  - Advanced power management
- Trace matched output impedance
- Line-side loopback
- Low EMI emissions
- Cable plant diagnostic
  - Cable plant analyzer function detects cable plant impairments
  - Link-quality indication LED
  - Automatic detection and correction of wiring pair swaps, pair skew, and pair polarity
  - Automatic MDI/MDIX crossover at all speeds
- Robust cable-sourced electrostatic discharge (CESD) tolerance
- Support for jumbo packets up to 10 KB
- IEEE 1149.1 (JTAG) boundary scan
- Package: 354-pin BGA

### SUMMARY OF BENEFITS

- Low-power quad-port integration enables single-row, high port density switches
  - Lowers system costs by eliminating PCB layers required for routing high density solutions
  - Reduced I/O pin requirements with RGMII (over 50%), SGMII (over 75%), and SerDes (over 80%)
  - Clock timing can be adjusted to eliminate board trace delays required by the RGMII specification
  - Lowers MAC/switch costs by reducing the number of pins required to interface to the PHY
- Flexibility for copper or fiber applications
- Provides compatibility with IEEE standard devices operating at 10, 100, and 1000 Mbps at half-duplex and full-duplex
- Requires no air flow or heat sink
- Eases system level debug
- Enables use of low cost magnetics, even in high density (48+) designs
- Cable diagnostic function characterizes cable plant condition and immediately indicates cabling issues
  - Prevents erroneous equipment return due to bad cable plants
  - Prevents manufacturing fall-out due to bad cable plants
- Over 4kV of CESD tolerance prevents equipment damage and return
- Operates with larger packets for wider range of packet protocol support and improved efficiency
- Ease of manufacturing with JTAG support, simplified power supply, and multiple MAC interfaces

**BCM5464S System Diagram**

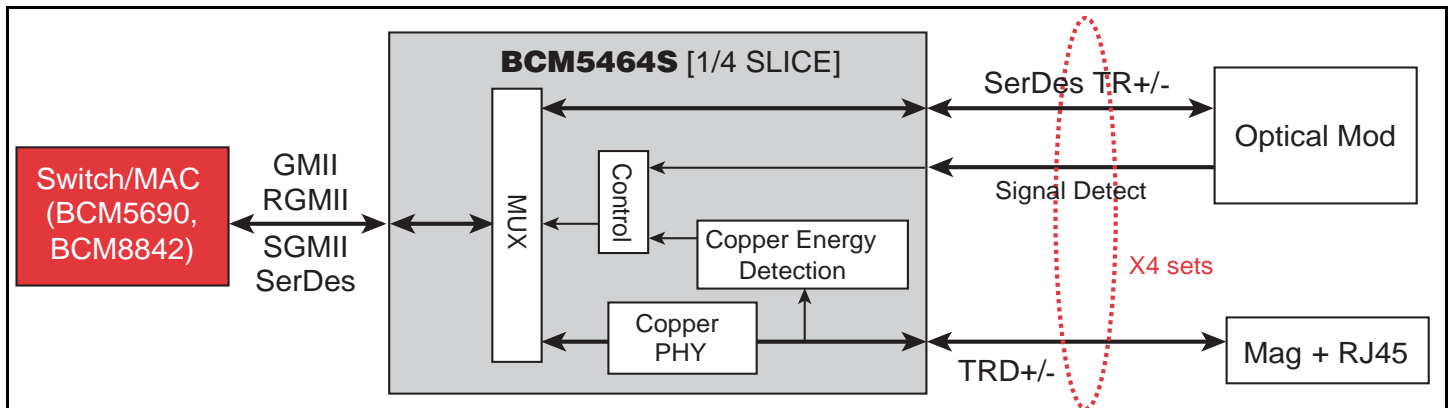

# OVERVIEW

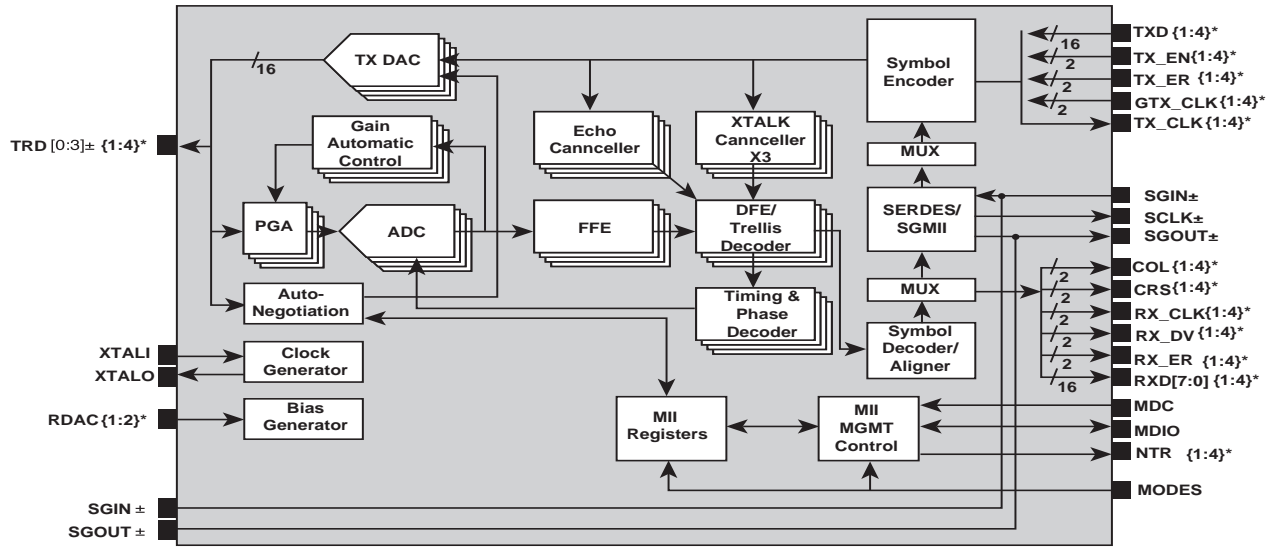

\*{1:4} Refers to the four separate Gigabit transceivers in the BCM5464S

The **BCM5464S** consists of four complete 10/100/1000BASE-T Gigabit Ethernet transceivers integrated on a single monolithic CMOS chip, and is a member of Broadcom's QuadSquad™ family of quad Gigabit Ethernet PHYs. The **BCM5464S** is optimized for low-power and small footprint size to enable high port density applications. The **BCM5464S** enables a new class of cost effective Gigabit Ethernet equipment by lowering system cost and reducing power dissipation by nearly 25%, driving the delivery of Gigabit bandwidth to the desktop.

The **BCM5464S** digital signal processor based architecture and advanced power management techniques combine to achieve robust and low-power operation over the existing Category 5 twisted-pair wiring. The **BCM5464S** architecture not only meets the requirements of IEEE's 802.3, 802.3u, and 802.3ab, but maintains the industry's highest level of margin over IEEE requirements for echo, NEXT, and FEXT. Low-power is key to implementing high-density Gigabit switches, and the **BCM5464S** has the lowest power in the industry at less than 750 mW per port. In addition, the **BCM5464S** has extremely low EMI emissions, which reduces the design constraints required to meet EMI radiation specifications.

The **BCM5464S** supports GMII, RGMII, SGMII, and SerDes MAC interfaces. A unique feature of the **BCM5464S** is its ability to support both copper and fiber networks, with an integrated SerDes PHY interface that can connect directly to a fiber-optic module. Switching between copper and fiber media can be accomplished either automatically or through software control. The **BCM5464S** monitors copper link and

fiber signal detect status, and automatically swaps either copper traffic or fiber traffic to the MAC/switch based on priorities set at initialization.

This device is another member of Broadcom's 0.13-µm Gigabit copper PHY family, joining the BCM5404, BCM5414, BCM5421, BCM5421S, BCM5424, and BCM5434. The 0.13-µm process is the optimal process that offers the best performance, lowest cost, and lowest power for Gigabit copper solutions. Devices based on the 0.13-µm process offer an excellent long term cost curve, enabling better cost reduction over time compared to older technologies without having to redesign or requalify a new part.

Each part of the **BCM5464S** is fully independent and has individual interface, control and status registers, and incorporates a number of advanced features. A link quality indicator LED gives installers an instant visual indication if there are any problems with the wiring plant supporting operation at the preferred speed. This includes physical wiring defects that the **BCM5464S** cannot automatically correct for, channel conditions such as excessive cable length and return loss, crosstalk, echo, and noise. Broadcom's cable analyzer software can be used with the device to provide remote management of the cable and a first level of diagnostics and fault isolation.

The **BCM5464S** also has ESD tolerance well above typical industry standards. This prevents ESD damage not only during manufacturing but during CESD events in the field. The CESD is an ESD event that occurs when an electrically charged network cable is plugged into a network port, which is an issue becoming more prevalent with recent cable installations. The BCM5464 can tolerate over 4 kV of CESD.

Broadcom®, the pulse logo, and Connecting everything® are trademarks of Broadcom Corporation and/or its subsidiaries in the United States and certain other countries. All other trademarks mentioned are the property of their respective owners.

Connecting  
everything®



**BROADCOM CORPORATION**  
16215 Alton Parkway, P.O. Box 57013  
Irvine, California 92619-7013

© 2003 by BROADCOM CORPORATION. All rights reserved.

5464S-PB07-R 12/10/03

Phone: 949-450-8700  
Fax: 949-450-8710  
E-mail: info@broadcom.com  
Web: www.broadcom.com

## X-ON Electronics

Largest Supplier of Electrical and Electronic Components

*Click to view similar products for [Ethernet ICs category](#):*

*Click to view products by [Broadcom manufacturer](#):*

Other Similar products are found below :

[EZFM6324A S LKA5](#) [EZFM6364A S LKA7](#) [12200BS23MM](#) [EZFM5224A S LKA3](#) [VSC8522XJQ-02](#) [WGI219LM SLKJ3](#) [EZFM6348A S LKA6](#) [WGI219V SLKJ5](#) [BCM84793A1KFSBG](#) [BCM56680B1KFSBLG](#) [BCM53402A0KFSBG](#) [BCM56960B1KFSBG](#) [EZX557AT2 S LKVX](#) [BCM56842A1KFTBG](#) [BCM56450B1KFSBG](#) [EZX557AT S LKW4](#) [LAN9254-I/JRX](#) [RTL8211FS-CG](#) [RTL8153-VC-CG](#) [CH395L KTI225IT S LNNK](#) [KTI225IT S LNNL](#) [VSC8562XKS-14](#) [BCM56864A1IFSBG](#) [KSZ8462FHLLI](#) [LAN9303MI-AKZE](#) [KSZ8841-16MVLI](#) [KSZ8842-16MVLI](#) [KSZ8893MQL](#) [VSC8244XHG](#) [ADIN2111BCPZ](#) [ADIN2111CCPZ-R7](#) [FIDO2100BGA128IR0](#) [FIDO5210CBCZ](#) [FIDO5210BBCZ](#) [FIDO5110CBCZ](#) [FIDO5200CBCZ](#) [ADIN1110BCPZ](#) [ADIN1110CCPZ](#) [ADIN1100BCPZ](#) [ADIN1110CCPZ-R7](#) [ADIN1100CCPZ-R7](#) [ADIN1110BCPZ-R7](#) [DM9000EP](#) [DM9161AEP](#) [HG82567LM S LAVY](#) [LAN9210-ABZJ](#) [LAN9221-ABZJ](#) [LAN9221I-ABZJ](#) [LAN9211-ABZJ](#)