

HCMS-235x

CMOS Extended Temperature Range 5 × 7 Alphanumeric Display

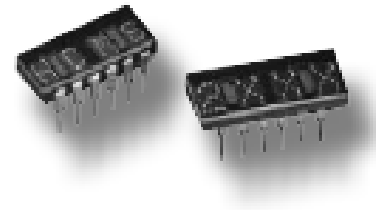

Description

The Broadcom[®] HCMS-235x sunlight viewable 5 × 7 LED four-character display is contained in 12-pin dual-inline packages designed for displaying alphanumeric information. The display is designed with on-board CMOS integrated circuits. Two CMOS ICs form an on-board 28-bit serial-in/parallel-out shift register with constant current output LED row drivers. Decoded column data is clocked into the on-board shift register for each refresh cycle. Full character display is achieved with external column strobing.

Features

- On-board low power CMOS IC
Integrated shift register with constant current LED drivers
- Wide operating temperature range
–55°C to +100°C
- Compact glass ceramic four-character package
Series X-Y stackable
- Sunlight viewable
- 5 × 7 LED matrix displays full ASCII set
- Character height of 5.0 mm (0.20 in.)
- Wide viewing angle
X Axis = ±50°
Y Axis = ±65°
- Usable in night vision lighting applications

Applications

- Avionics
- Communication systems
- Fire control systems
- Radar systems

Package Dimensions

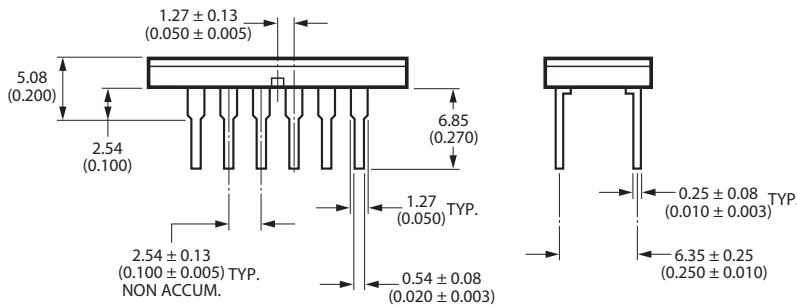
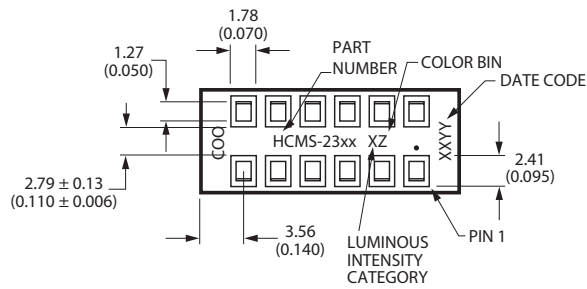
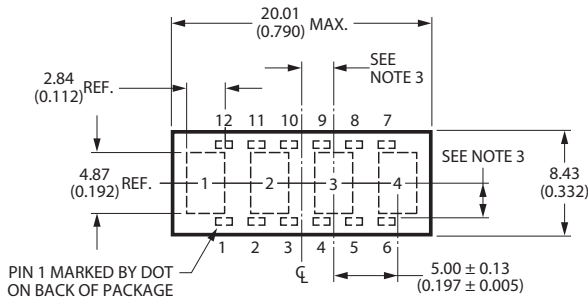

PIN	FUNCTION	PIN	FUNCTION
1	COLUMN 1	7	DATA OUT
2	COLUMN 2	8	VB
3	COLUMN 3	9	V _{DD}
4	COLUMN 4	10	CLOCK
5	COLUMN 5	11	GROUND
6	INT. CONNECT*	12	DATA IN

* DO NOT CONNECT OR USE

- NOTES:
1. DIMENSIONS IN MILLIMETERS (INCHES).
 2. UNLESS OTHERWISE SPECIFIED, THE TOLERANCE ON ALL DIMENSIONS IS ± 0.38 mm (± 0.015).
 3. CHARACTERS ARE CENTERED WITH RESPECT TO LEADS WITHIN ± 0.13 mm (± 0.005).
 4. LEAD MATERIAL IS COPPER ALLOY, SOLDER DIPPED.

Absolute Maximum Ratings

Parameter	Value
Supply Voltage V _{DD} to Ground	-0.3V to 7.0V ^a
Data Input, Data Output, V _B	-0.3V to V _{DD}
Column Input Voltage, V _{COL}	-0.3V to V _{DD}
Free Air Operating Temperature Range, T _A	-55°C to +100°C
Storage Temperature Range, T _S	-55°C to +100°C ^{b, c}
Maximum Allowable Package Power Dissipation, P _D ^{b, c} at T _A = 71°C	1.31W
Through-the-Wave Solder Temperature ^d	250°C for 3 seconds maximum
Solder Dipping Temperature ^d	260°C for 5 seconds maximum
ESD Protection at 1.5 kΩ, 100 pF	V _Z = 4 kV

- Maximum duration 2 seconds.
- Maximum allowable power dissipation is derived from V_{DD} = 5.25V, V_B = 2.4V, V_{COL} = 3.5V, 20 LEDs ON per character, 20% DF.
- HCMS-2353 derate above 71°C at 23 mW/°C, R_{θJA} = 45°C/W.
Derating based on R_{θJA} = 35°C/W per display for printed circuit board assembly.
- 1.59 mm (0.063 in.) below body.

Recommended Operating Conditions

Over Operating Range (–55°C to +100°C)

Parameter	Symbol	Min.	Typ.	Max.	Units
Supply Voltage	V_{DD}	4.75	5.00	5.25	V
Data Out Current, Low State	I_{OL}	—	—	1.6	mA
Data Out Current, High State	I_{OH}	—	—	–0.5	mA
Column Input Voltage	V_{COL}	2.75	3.0	3.5	V
Setup Time	t_{SETUP}	10	—	—	ns
Hold Time	t_{HOLD}	25	—	—	ns
Clock Pulse Width High	$t_{WH(CLOCK)}$	50	—	—	ns
Clock Pulse Width Low	$t_{WL(CLOCK)}$	50	—	—	ns
Clock High to Low Transition	t_{THL}	—	—	200	ns
Clock Frequency	f_{CLOCK}	—	—	5	MHz

Electrical Characteristics Over Operating Range (–55°C to + 100°C)

Parameter	Symbol	Test Conditions	Min.	Typ. ^a	Max.	Units
Supply Current, Dynamic ^b	I _{DDD}	f _{CLOCK} = 5 MHz	—	6.2	7.8	mA
Supply Current, Static ^c	I _{DDSoFF}	V _B = 0.4V, Data and Clock = 0.4V	—	1.8	26	mA
	I _{DDSoN}	V _B = 2.4V, Data and Clock = 0.4V	—	2.2	6.0	
Column Input Current	I _{COL}	V _B = 0.4V	—	—	10	μA
		V _B = 2.4V	—	500	650	mA
Input Logic High Data, V _B , Clock	V _{IH}	V _{DD} = 4.75V	2.0	—	—	V
Input Logic Low Data, V _B , Clock	V _{IL}	V _{DD} = 5.25V	—	—	0.8	V
Input Current Data Clock, V _B	I _I	V _{DD} = 5.25V V ^d = 2.4V (Logic High) or V ^d = 0.4V (Logic Low)	–46 –92	–60 –120	–103 –206	μA
Data Out Voltage	V _{OH}	V _{DD} = 4.75V I _{OH} = –0.5 mA I _{COL} = 0 mA	2.4	4.2	—	V
	V _{OL}	V _{DD} = 5.25V I _{OL} = 1.6 mA I _{COL} = 0 mA	—	0.2	0.4	V
Power Dissipation Per Package ^e	P _D	V _{DD} = 5.0V V _{COL} = 3.5V 17.5% DF V _B = 2.4V 15 LEDs ON per Character	—	668	—	mW
Thermal Resistance IC Junction-to-Pin ^f	R _{θJ-PIN}		—	10	—	°C/W
Leak Rate			—	—	5 × 10 ^{–8}	cc/second

a. All typical values specified at V_{DD} = 5.0V and T_A = 25°C.

b. I_{DD} Dynamic is the IC current while clocking column data through the on-board shift register at a clock frequency of 5 MHz, the display is not illuminated.

c. I_{DD} Static is the IC current after column data is loaded and not being clocked through the on-board shift register.

d. V_I represents the input voltage to an input pin.

e. Four characters are illuminated with a typical ASCII character composed of 15 dots per character.

f. IC junction temperature T_J (IC) = (P_D)(R_{θJ-PIN} + R_{θPC-A}) + T_A.

Optical Characteristics at $T_A = 25^\circ\text{C}$

High Performance Green, HCMS-2353

Description	Symbol	Test Conditions	Min.	Typ. ^a	Max.	Units
Peak Luminous Intensity per LED ^b (Character Average)	I_{VPEAK}	$V_{DD} = 5.0V$ $V_{COL} = 3.5V$ $V_B = 2.4V$ $T_i = 25^\circ\text{C}^c$	2400	3000	—	μcd
Dominant Wavelength ^{d, e}	λ_d		—	574	—	nm
Peak Wavelength	λ_{PEAK}		—	568	—	nm

- All typical values specified at $V_{DD} = 5.0V$ and $T_A = 25^\circ\text{C}$ unless otherwise noted.
- These LED displays are categorized for luminous intensity, with the intensity category designated by a letter code on the back of the package.
- T_i refers to the initial case temperature of the display immediately prior to the light measurement.
- Dominant wavelength, λ_d , is derived from the CIE Chromaticity Diagram, and represents the single wavelength that defines the color of the device.
- Categorized for color with the color category designated by a number on the back of the package.

Yellow, HCMS-2351

Description	Symbol	Test Condition	Min	Typ. ^a	Max.	Units
Peak Luminous Intensity per LED ^b (Character Average)	I_{VPEAK}	$V_{DD} = 5.0V$ $V_{COL} = 3.5V$ $V_B = 2.4V$ $T_i = 25^\circ\text{C}^c$	1600	2400	—	mcd
Dominant Wavelength ^{d, e}	λ_d	—	—	585	—	nm
Peak Wavelength	λ_{PEAK}	—	—	583	—	nm

- All typical values specified at $V_{DD} = 5.0V$ and $T_A = 25^\circ\text{C}$ unless otherwise noted.
- These LED displays are categorized for luminous intensity, with the intensity category designated by a letter code on the back of the package.
- T_i refers to the initial case temperature of the display immediately prior to the light measurement.
- Dominant wavelength, λ_d , is derived from the CIE Chromaticity Diagram, and represents the single wavelength that defines the color of the device.
- Categorized for color with the color category designated by a number on the back of the package.

Switching Characteristics

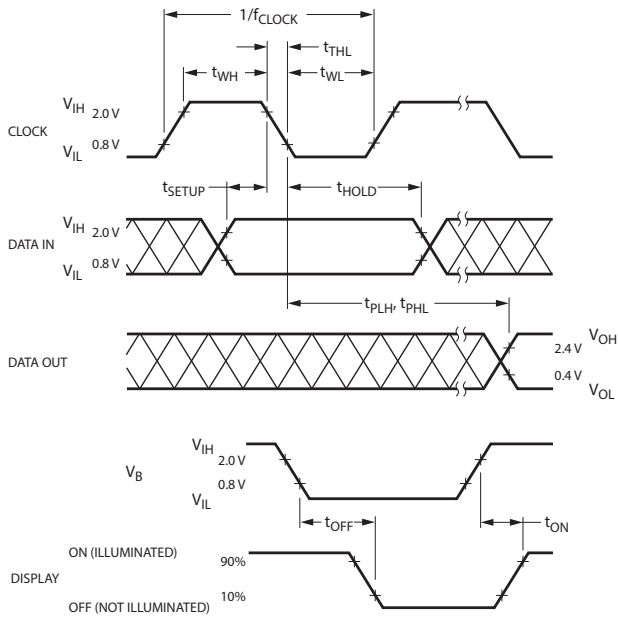

Parameter	Condition	Typ.	Max.	Units
f_{clock} CLOCK Rate		—	5	MHz
$t_{\text{PLH}}, t_{\text{PHL}}$ Propagation Delay CLOCK to DATA OUT	$C_L = 15 \text{ pf}$ $R_L = 2.4 \text{ k}\Omega$	—	105	ns
t_{OFF} $V_B (0.4\text{V})$ to Display OFF		4	5	μs
t_{ON} $V_B (2.4\text{V})$ to Display ON		1	2	

Electrical Description

The display contains four 5 × 7 LED dot matrix characters and two CMOS integrated circuits, as shown in [Figure 1](#). The two CMOS integrated circuits form an on-board 28-bit serial-in/parallel-out shift register that accepts standard TTL logic levels. The Data Input, pin 12, is connected to bit position 1 and the Data Output, pin 7, is connected to bit position 28. The shift register puts out control constant current sinking LED row drivers. A logic 1 stored in the shift register enables the corresponding LED row driver and a logic 0 stored in the shift register disables the corresponding LED row driver.

The electrical configuration of these CMOS IC alphanumeric displays allows for an effective interface to a display controller circuit, which supplies decoded character information. The row data for a given column (one 7-bit byte per character) is loaded (bit serial) into the on-board 28-bit shift register with high-to-low transitions of the clock input.

To load decoded character information into the display, column data for character 4 is loaded first, and the column data for character 1 is loaded last in the following manner. The 7 data bits for column 1, character 4, are loaded into the on-board shift register. Next, the 7 data bits for column 1, character 3, are loaded into the shift register, shifting the character 4 data over one character position.

This process is repeated for the other two characters until all 28 bits of column data (four 7-bit bytes of character column data) are loaded into the on-board shift register. Then the column 1 input, V_{COL} pin 1, is energized to illuminate column 1 in all four characters. This process is repeated for columns 2, 3, 4, and 5. All V_{COL} inputs should be at logic low to ensure that the display is off when loading data. The display is blank when the blanking input V_B , pin 8, is at logic low regardless of the outputs of the shift register or whether one of the V_{COL} inputs is energized. Refer to Application Note 1016 for drive circuit information.

Figure 1: Display Block Diagram

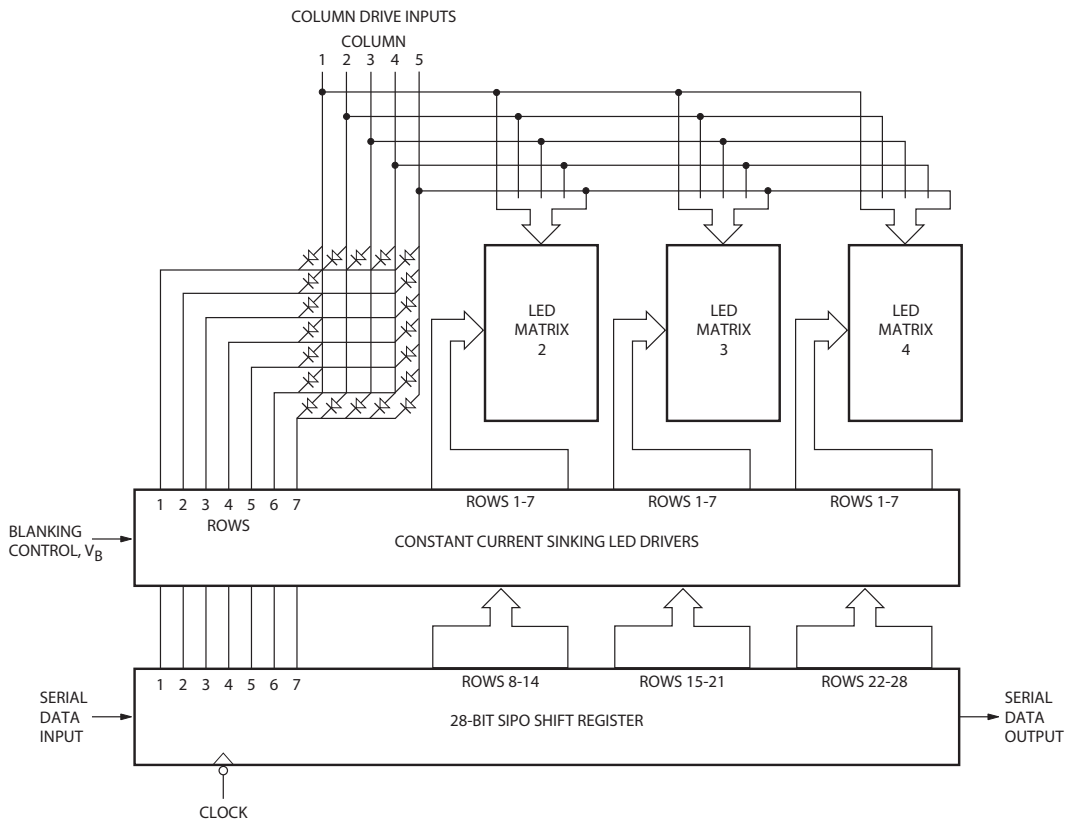

ESD Susceptibility

The display has an ESD susceptibility rating of Class 3 of MIL-STD-883E, HBM. Take normal CMOS handling precautions when handling these devices.

Soldering and Post Solder Cleaning

These displays may be soldered with a standard wave solder process using either an RMA flux and solvent cleaning or an OA flux and aqueous cleaning. For optimum soldering, the solder wave temperature should be 245°C, and the dwell time for any display lead passing through the wave should be 1.5 to 2 seconds. For more detailed information, refer to Application Note 1027, *Soldering LED Components*.

Contrast Enhancement

When used with the proper contrast enhancement filters, the display is readable in sunlight.

Refer to Application Note 1029, *Luminous Contrast and Sunlight Readability of the HDSP-235X Series Alphanumeric Displays for Sunlight Viewable Applications*, for information on contrast enhancement for sunlight and daylight ambient. Refer to Application Note 1015, *Contrast Enhancement Techniques for LED Displays*, for information on contrast enhancement in moderate ambients.

Night Vision Lighting

When used with the proper NVG/DV filters, the HCMS-235x display may be used in night vision lighting applications. For a list of NVG/DV filters and a description on night vision lighting technology, refer to Application Note 1030, *LED Displays and Indicators and Night Vision Imaging System Lighting*.

Controller Circuits, Power Calculations, and Display Dimming

Refer to Application Note 1016, *Using the HDSP-2000 Alphanumeric Display Family*, for information on controller circuits to drive these displays, how to do power calculations, and a technique for display dimming.

Figure 2: Peak Column Current vs. Column Voltage at T_A = 25°C

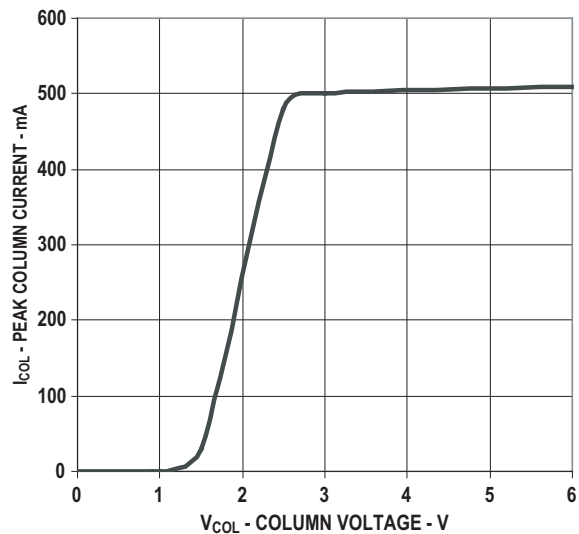

Intensity Bin Limits

Intensity Bin Limits for HCMS-2351

Bin	Intensity Range (mcd)	
	Min.	Max.
Q	11.197	15.774
R	13.437	19.718
S	16.797	23.662
T	20.156	29.577
U	25.195	35.492

Intensity Bin Limits for HCMS-2353

Bin	Intensity Range (mcd)	
	Min.	Max.
S	16.797	23.662
T	20.156	29.577
U	25.195	35.492
V	30.234	44.366
W	37.739	52.239

Color Bin Limits

Color	Color Bin	QA	
		Min.	Max.
Yellow	3	581.5	585.0
	4	584.0	587.5
	5	586.5	590.0
	6	589.0	592.5
	7	591.5	595.0
Green	1	576.0	580.0
	2	573.0	577.0
	3	570.0	574.0
	4	567.0	571.0

NOTE: Test conditions as specified in [Optical Characteristics](#) at $T_A = 25^\circ\text{C}$.

Option Code Definition

H C M S - 2 3 5 x - x₁ x₂ x₃ x x

Iv Bin Range Identifier		
x ₁ x ₂	x ₁	Minimum Iv bin
	x ₂	Maximum Iv bin
Color Bin Range Identifier		
x ₃	A	Color bin 2 or 3
	B	Color bin 4 or 5
	C	Color bin 5 or 6
	D	Color bin 3 or 4

Broadcom, the pulse logo, Connecting everything, Avago Technologies, Avago, and the A logo are among the trademarks of Broadcom and/or its affiliates in the United States, certain other countries, and/or the EU.

Copyright © 2008–2019 Broadcom. All Rights Reserved.

The term “Broadcom” refers to Broadcom Inc. and/or its subsidiaries. For more information, please visit www.broadcom.com.

Broadcom reserves the right to make changes without further notice to any products or data herein to improve reliability, function, or design. Information furnished by Broadcom is believed to be accurate and reliable. However, Broadcom does not assume any liability arising out of the application or use of this information, nor the application or use of any product or circuit described herein, neither does it convey any license under its patent rights nor the rights of others.

X-ON Electronics

Largest Supplier of Electrical and Electronic Components

Click to view similar products for [LED Displays & Accessories](#) category:

Click to view products by [Broadcom](#) manufacturer:

Other Similar products are found below :

[LTC-2721WC](#) [LTC-4624JD](#) [LTC-4627G](#) [LTC-4627WC](#) [LTD-5021AWC](#) [LTM-8522G](#) [LTP-4323P](#) [LTP-747G](#) [LTS-3361JG-06](#)
[F416SYGWA/S530-E3](#) [1668](#) [HT-F196NB-5323](#) [IPD2131-27](#) [SA03-12EWA](#) [LDD-E2802RD](#) [LDD-E306MI](#) [LDQ-N514RI](#) [LDS-A3506RD](#)
[LDS-A3926RI](#) [LDT-M516RI](#) [SC03-12HDB](#) [SI-B9T151550WW](#) [SI-B9V171550WW](#) [SLC-3PF-WL](#) [1624](#) [LTC-2621JD](#) [LTC-2623WC](#) [LTC-](#)
[4624P](#) [LTC-4627JD](#) [LTD-2601E](#) [LTD-2601P](#) [LTD-322G](#) [LTD-482PC](#) [LTP-1457AKR](#) [LTP-3784G-01](#) [LTS-313AP](#) [LTS-4812SKR-P](#) [LTS-](#)
[547AE](#) [LTS-6780P](#) [446010401-3](#) [HV-7W30-6829](#) [CA12240_MINNIE-WWW-MTG-ASSY](#) [DA43-11GWA](#) [LDD-A516RI-17](#) [LDD-E305RI](#)
[LDQ-M513RI](#) [LDQ-M5204RI-SI](#) [LDQ-N3402RI](#) [LDQ-N3606RI](#) [LDT-M2804RI](#)