

MGA-16316

Dual LNA for Balanced Application 1950 – 4000 MHz



Data Sheet

Description

Avago Technologies' MGA-16316 is an ultra low-noise high linearity amplifier pair with built-in active bias and shutdown features for balanced applications in the 2600 MHz band. Shutdown functionality is achieved using a single DC voltage input pin. High linearity is achieved through the use of Avago Technologies' proprietary GaAs Enhancement-mode pHEMT process^[1]. It is housed in a miniature 4.0 x 4.0 x 0.85 mm 16-pin Quad Flat No-lead (QFN). The compact footprint coupled with ultra low noise and high linearity makes MGA-16316 an ideal choice for basestation transmitters and receivers.

For applications < 1950 MHz, it is recommended to use MGA-16216 1440-2350 MHz or MGA-16116 450-1450 MHz. All 3 products share the same package and pin out configuration.

Component Image

4.0 x 4.0 x 0.85 mm³ 16-Lead QFN



Note:
 Package marking provides orientation and identification
 "16316" = Device Code
 "YYWW" = Date Code identifies year and work week of manufacturing
 "XXXX" = Last 4 digit of assembly lot number

Pin Configuration

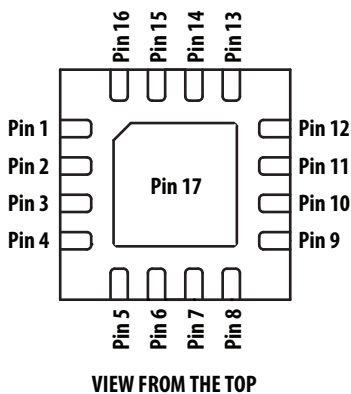

Pin	Use	Pin	Use
1	RFIN1	10	GND
2	GND	11	GND
3	GND	12	RFOUT1
4	RFIN2	13	Not used
5	Bias_out2	14	Bias_in1
6	Vsd2	15	Vsd1
7	Bias_in2	16	Bias_out1
8	Not used	17	GND
9	RFOUT2	-	-

Features

- Ultra Low Noise Figure
- Variable Bias and Shutdown functionality
- High IIP3: +15.5 dBm typ.
- GaAs E-pHEMT Technology^[1]
- Small package size: 4.0 x 4.0 x 0.85 mm³
- RoHS and MSL1 compliant.

Typical Performances

2600 MHz @ 4.8 V, 53.3 mA (typ per amplifier)

- Gain: 18.2 dB
- NF: 0.45 dB^[2]
- IIP3: 15.5 dBm
- P1dB: 18.7 dBm
- Shutdown voltage Vsd range > 1.5 V
- Shutdown current (Vsd1, Vsd2 = 3 V): 5.1 mA

Applications

- Basestation receivers and transmitters in balanced configuration.
- Ultra low-noise RF amplifiers.

Notes:

1. Enhancement mode technology employs positive Vgs, thereby eliminating the need of negative gate voltage associated with conventional depletion mode devices.
2. Measured at RFin pin of packaged part, other losses deembedded.
3. Good RF practice requires all unused pins to be grounded.



Attention: Observe precautions for handling electrostatic sensitive devices.
 ESD Machine Model = 60V
 ESD Human Body Model = 300V
 Refer to Avago Application Note A004R: Electrostatic Discharge, Damage and Control.

Absolute Maximum Rating^[1] $T_A = 25^\circ\text{C}$

Symbol	Parameter	Units	Absolute Maximum
V _{dd}	Drain Voltage, RF output to ground	V	5.5
I _{dd}	Drain Current	mA	100
V _{sd}	Shutdown Voltage	V	5.5
P _{in}	CW RF Input Power with LNA On	dBm	27
P _{in}	CW RF Input Power with LNA Off	dBm	27
P _d	Power Dissipation	mW	550
T _j	Junction Temperature	°C	150
T _{stg}	Storage Temperature	°C	-65 to 150

Thermal Resistance^[3]

(V_d = 4.8V, I_{dd} = 52.5 mA, T_c = 100° C)
 $\theta_{jc} = 51.3^\circ\text{C/W}$

Notes:

1. Operation of this device in excess of any of these limits may cause permanent damage.
2. Source lead temperature is 25° C. Derate 19 mW/°C for T_c > 122° C.
3. Thermal resistance measured using 150° C Infra-Red Microscopy Technique.

Electrical Specifications

T_A = 25° C, V_{dd1} = V_{dd2} = 4.8 V, V_{sd1} = V_{sd2} = 0 V at R_{bias} = 1 Kohm, RF performance at 2600 MHz, CW operation unless otherwise stated.

Symbol	Parameter and Test Condition	Units	Min.	Typ.	Max.
V _{dd}	Supply Voltage	V		4.8	
I _{dd}	Total Supply Current per amplifier (I _{dq} +I _{bias})	mA	44	53.3	65
Gain	Gain	dB	17.2	18.2	19.4
NF ^[1]	Noise Figure	dB		0.45	0.65
OP1dB	Output Power at 1dB Gain Compression	dBm		18.7	
IIP3 ^[2]	Input Third Order Intercept Point	dBm	13.5	15.5	
S11	Input Return Loss, 50 Ω source	dB		-12.7	
S22	Output Return Loss, 50 Ω load	dB		-4.4	
S12	Reverse Isolation	dB		-32.2	
S31	Isolation between R _{Fin1} and R _{Fin2}	dB		-41.6	
V _{sd1,2} ^[3]	Maximum Shutdown voltage required to turn ON LNA	V		0.5	
V _{sd1,2} ^[3]	Minimum Shutdown voltage required to turn OFF LNA	V		2.0	
I _{dq} ^[4]	Current at V _{dd} with V _{sd} = 0 V	mA		49.4	
	Current at V _{dd} with V _{sd} = 3 V	mA		0.39	
I _{sd} ^[4]	Current at V _{sd} with V _{sd} = 0 V	μA		4	
	Current at V _{sd} with V _{sd} = 3 V	mA		0.175	
I _{bias} ^[4]	Current at V _{bias} with V _{sd} = 0 V	mA		3.9	
	Current at V _{bias} with V _{sd} = 3 V	mA		4.52	

Notes:

1. Noise figure at the DUT RF Input pin, board losses are deembedded.
2. IIP3 test condition: FRF1-FRF2 = 1 MHz with input power of -20 dBm per tone.
3. V_{sd1} and V_{sd2} are active LOW
4. Refer to Figure 6 for more details.

Product Consistency Distribution Charts

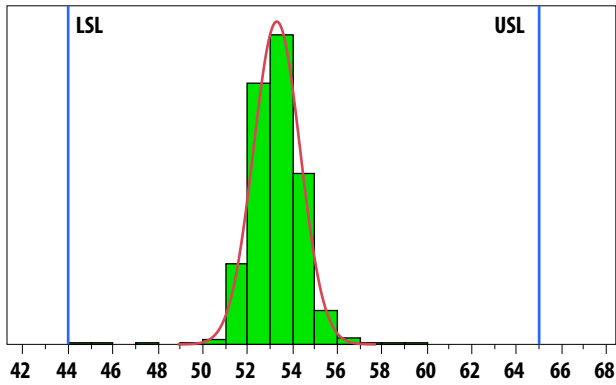

Figure 1. Idd, LSL = 44 mA, nominal = 53.3 mA, USL = 65 mA

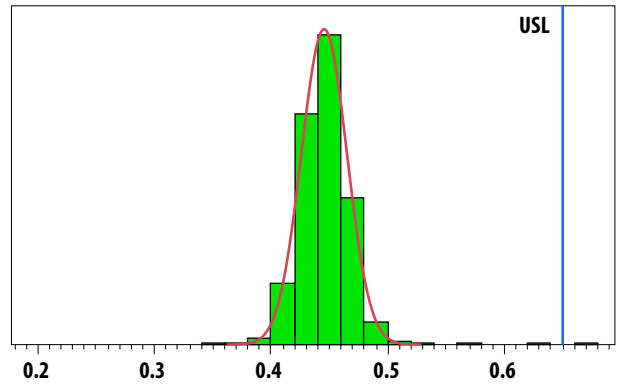

Figure 2. NF, nominal = 0.45 dB, USL = 0.65 dB

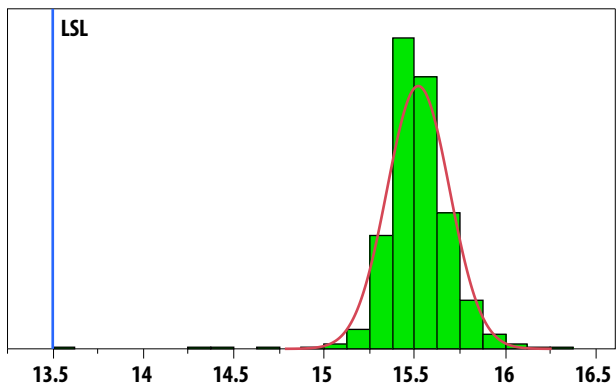

Figure 3. IIP3, LSL = 13.5 dBm, nominal = 15.5 dBm

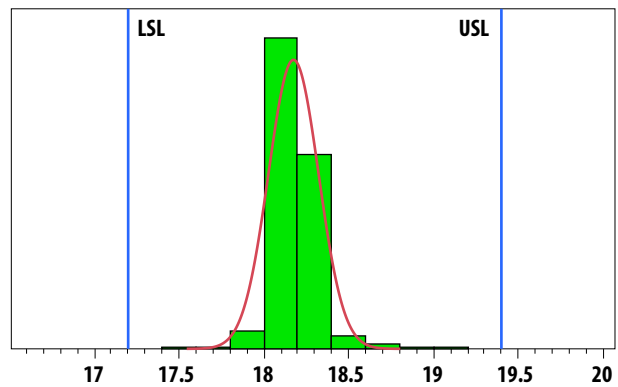

Figure 4. Gain, LSL = 17.2 dB, nominal = 18.2 dB, USL = 19.4 dB

Notes:

1. Distribution data sample size is 3500 samples taken from 6 different wafer lots. Future wafers allocated to this product may have nominal values anywhere between the upper and lower limits.
2. Circuit trace losses for NF have been de-embedded from measurements above.

Demo Board Layout

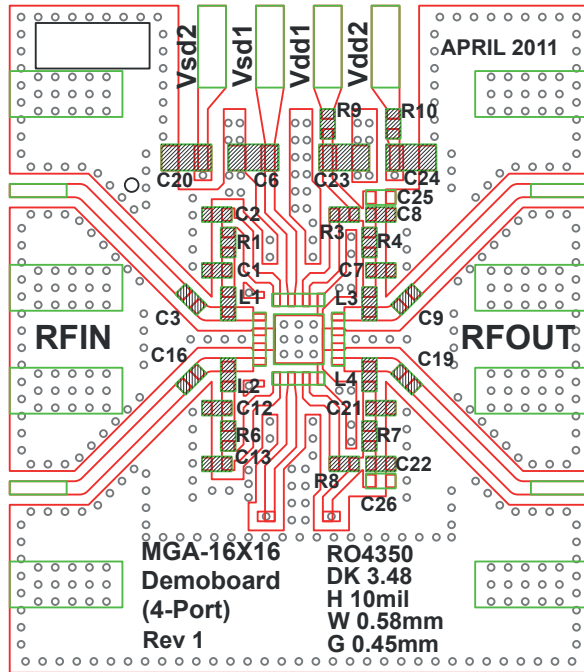

Figure 5. Demo Board Layout Diagram

Demo Board Schematic

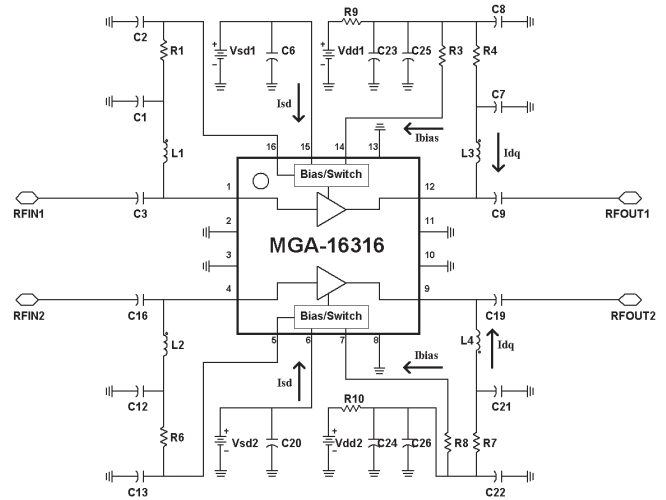

Figure 6. Demo Board Schematic Diagram

Notes:

1. Recommended PCB material is 10 mils Rogers RO4350.
2. Suggested component values may vary according to layout and PCB material.
3. Input board loss at 2600MHz is 0.17dB.
4. The schematic is shown with the assumption that similar PCB is used for all MGA-16116, MGA-16216 and MGA-16316.
5. Detail of the components needed for this product is shown in Table 1
6. R1 and R6 are for low frequency stability.
7. Bias to each LNA is adjustable using R3 and R8 (see Figure 6). Increasing R3 and R8 will reduce bias current (Idd) and vice-versa.
8. R9/R10 are stability improvement resistors that may not be needed in actual application. They are included in the demoboard to provide isolation from power supply noise.
9. Center Paddle is grounded.

Table 1. Component list for 2600 MHz matching

PART	Size	Value	Detail Part Number
C1, C12	0201	10 pF	GRM0335C1H100GD01
C2, C8, C13, C22	0402	0.1 μ F	GRM155R71C104KA88D
C9, C19	0201	1000 pF	GRM033R11E102KA01
C3, C16	0201	33 pF	GJM0335C0J330GB01
C6, C20, C23, C24	0805	4.7 μ F	GRM21BR61E475KA12
C7, C21	0201	15 pF	GRM0335C1H150GD01
C25, C26	0402	NOT USED	-
L1, L2	0603	10 nH	LQW18AN10NG00D
L3, L4	0603	6.8 nH	LQW18AN6N8C00D
R1, R4, R6, R7	0402	0 ohm	RK73Z1ETTP
R3, R8	0402	1 kohm	RK73B1ETTP102J
R9, R10	0402	10 ohm	RK73B1ETTP100J

Table 2. Below is the table showing the MGA-16316 Reflection Coefficient Parameters tuned for Maximum OIP3, Vdd = 4.8 V, Idd = 35 mA per amplifier. Input gamma is tuned for Fmin. The reflection coefficients are for single amplifier.

Frequency (MHz)	Gamma Load Position		IIP3 (dBm) ^[1]	Gain (dB)
	Magnitude	Angle		
1950	0.642	139.3	13.44	21.72
2350	0.514	144	13.43	21.08
2600	0.771	175.1	17.98	16.99
2700	0.771	175.1	19.22	17.07

Table 3. Below is the table showing the MGA-16316 Reflection Coefficient Parameters tuned for Maximum OIP3, Vdd = 4.8 V, Idd = 55 mA. per amplifier. Input gamma is tuned for Fmin. The reflection coefficients are for single amplifier.

Frequency (MHz)	Gamma Load Position		IIP3 (dBm) ^[1]	Gain (dB)
	Magnitude	Angle		
1950	0.642	139.3	19.55	22
2350	0.771	165.4	22.65	18.24
2600	0.771	175.1	23.91	17.2
2700	0.643	174.2	21.11	18.43

Table 4. Below is the table showing the MGA-16316 Reflection Coefficient Parameters tuned for Maximum OIP3, Vdd = 4.8 V, Idd = 75 mA per amplifier. Input gamma is tuned for Fmin. The reflection coefficients are for single amplifier.

Frequency (MHz)	Gamma Load Position		IIP3 (dBm) ^[1]	Gain (dB)
	Magnitude	Angle		
1950	0.642	127.7	19.04	23.17
2350	0.771	155.7	21.04	19.48
2600	0.771	155.6	21.39	19.72
2700	0.772	165.4	22.9	18.41

Notes:

1. IIP3 test condition: FRF1-FRF2 = 1 MHz with input power of -20 dBm per tone.
2. Idd can be obtained by varying the Vg1/Vg2. Refer to figure 7.

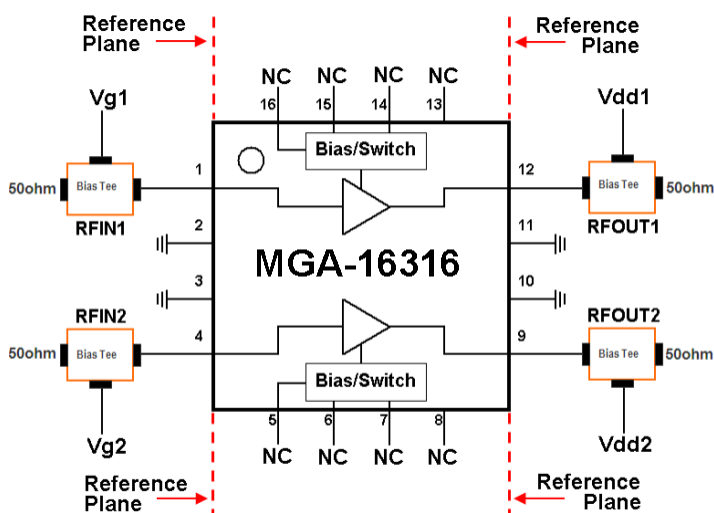

Figure 7. RFinput and RFoutput Reference Plane

Notes:

1. Maximum OIP3 is measured on coplanar waveguide made on 0.010 inch thick ROGER 4350.

Typical 2600 MHz RF Performance Plots

RF performance at $T_A = 25^\circ\text{C}$, $V_{dd} = 4.8\text{ V}$, $I_{dd} = 53\text{ mA}$, LNA mode, measured on demo board in Figure 5. Signal is CW unless stated otherwise. Application Test Circuit is shown in Figure 6 and Table 1. IIP3 test condition: FRF1-FRF2 = 1 MHz with input power of -20 dBm per tone.

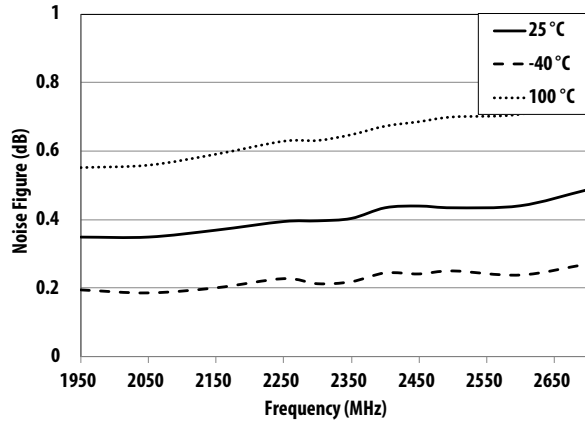

Figure 8. NF vs Frequency vs Temperature [1]

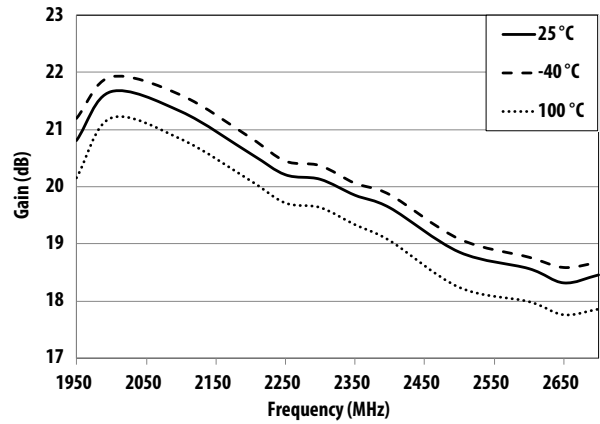

Figure 9. Gain vs Frequency vs Temperature

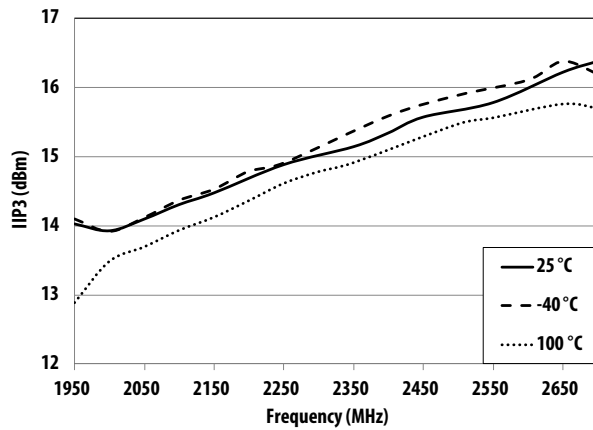

Figure 10. IIP3 vs Frequency vs Temperature

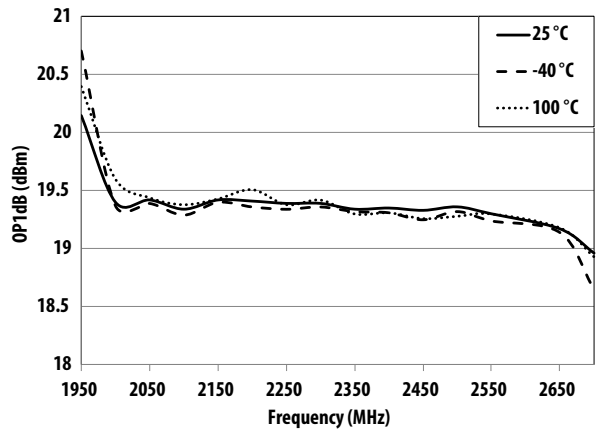

Figure 11. OP1dB vs Frequency vs Temperature

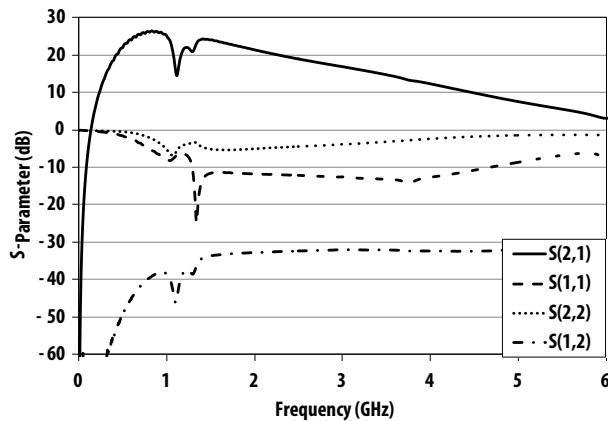

Figure 12. Input Return Loss, Output Return Loss, Gain, Reverse Isolation vs Frequency

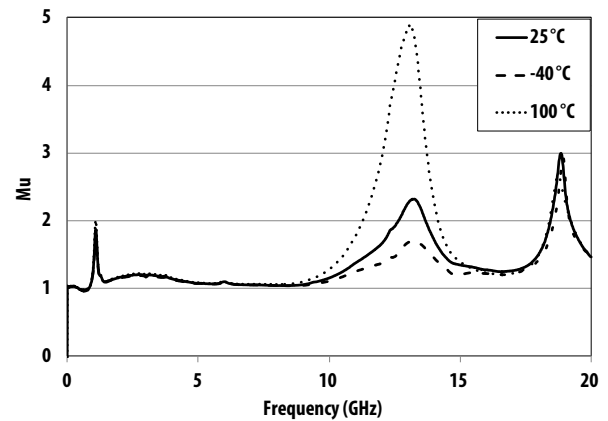

Figure 13. Mu stability factors vs Frequency vs Temperature

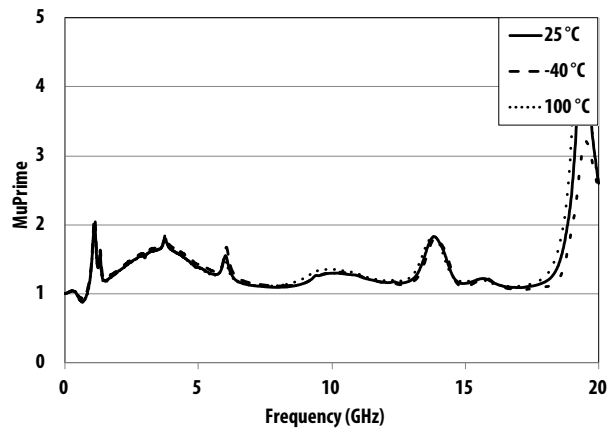

Figure 14. Mu' stability factors vs Frequency vs Temperature

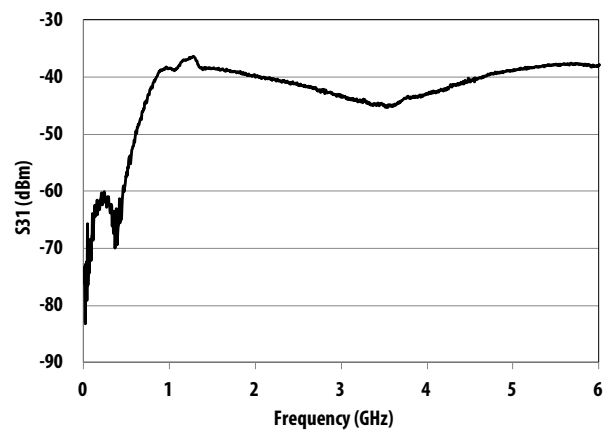

Figure 15. Input Ports Isolation (S31) vs Frequency

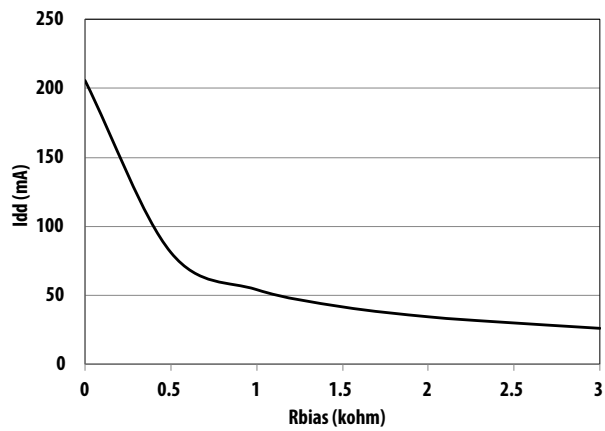

Figure 16. Idd vs Rbias^[2]

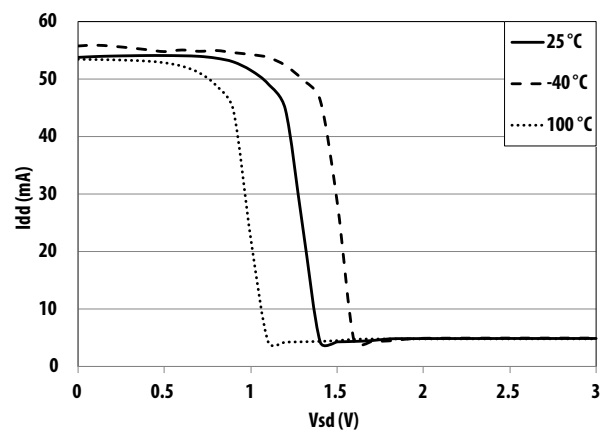

Figure 17. Idd vs Vsd

Notes:

1. Circuit trace losses for NF have been de-embedded from measurements above.
2. Rbias is R3 and R8 from Figure 6.

Table 5. Typical Scattering Parameters, Vdd = 4.8 V, Idd = 35 mA

LNA SPAR (100 MHz – 20 GHz) The S-parameter are for single amplifier.

Freq	S11	S11	S21	S21	S12	S12	S22	S22
(GHz)	(dB)	(ang)	(dB)	(ang)	(dB)	(ang)	(dB)	(ang)
0.1	-0.476	-11.795	30.600	166.000	-56.277	83.765	-0.872	-6.472
0.5	-2.441	-49.115	27.700	120.000	-42.100	60.515	-1.771	-29.610
0.7	-3.632	-61.714	25.893	104.931	-40.007	55.714	-2.111	-39.314
0.9	-4.923	-72.709	24.900	91.282	-38.700	51.691	-2.371	-48.818
1.0	-5.351	-76.823	23.990	85.409	-38.210	50.529	-2.464	-53.582
1.5	-7.431	-93.215	21.500	59.870	-36.115	44.600	-2.789	-77.245
1.7	-7.972	-99.434	20.600	50.366	-35.583	42.266	-2.890	-87.734
1.9	-8.410	-105.000	19.800	41.381	-35.000	39.962	-2.902	-98.019
2.0	-8.552	-108.000	19.400	36.880	-34.700	38.880	-2.912	-103.199
2.5	-8.980	-120.000	17.400	15.450	-33.800	34.050	-2.850	-130.249
3.0	-8.987	-129.000	15.500	-4.630	-33.100	30.430	-2.640	-157.000
3.5	-8.660	-136.000	13.800	-23.870	-32.500	29.835	-2.367	179.000
4.0	-8.210	-143.000	12.100	-42.440	-31.700	28.480	-2.010	155.000
4.5	-7.770	-150.000	10.400	-59.990	-30.600	27.890	-1.680	134.000
5.0	-7.410	-157.499	8.745	-77.000	-29.300	25.600	-1.400	114.002
5.5	-7.020	-166.000	7.085	-93.110	-28.000	22.445	-1.150	96.345
6.0	-6.738	-175.000	5.394	-109.000	-28.040	8.322	-1.140	77.780
7.0	-5.463	164.000	1.823	-136.000	-26.300	3.755	-0.689	52.130
8.0	-3.972	149.000	-0.916	-160.000	-24.100	-6.280	-0.481	33.300
9.0	-3.071	139.000	-3.289	173.000	-22.000	-22.190	-1.318	8.903
10.0	-2.680	121.001	-6.630	160.000	-21.600	-28.600	-3.520	4.340
11.0	-1.850	97.890	-7.921	129.000	-19.200	-49.210	-0.357	-17.410
12.0	-1.272	77.980	-11.500	103.000	-19.600	-65.920	-0.349	-30.120
13.0	-0.725	53.270	-13.130	79.170	-18.100	-77.600	-0.096	-27.530
14.0	-0.300	36.700	-14.500	46.260	-16.800	-96.680	-0.075	-46.040
15.0	-0.082	32.450	-14.700	20.050	-16.400	-105.000	-1.140	-72.950
16.0	-0.360	4.722	-13.800	-48.460	-10.000	-130.600	-0.674	-89.660
17.0	-2.586	-17.770	-12.900	-76.640	-10.700	-150.000	-0.452	-101.000
18.0	-2.914	-34.400	-16.400	-120.000	-10.600	165.000	-1.736	-110.000
19.0	-4.558	-55.810	-13.400	-161.000	-13.000	153.000	-3.332	-93.780
20.0	-8.330	-47.100	-16.100	153.000	-13.300	99.500	-5.280	-133.000

Table 6. Typical Noise Parameters, for single amplifier, Vdd = 4.8 V, Idd = 35 mA

Freq	Fmin	Γ_{opt}	Γ_{opt}	$R_{n/50}$
MHz	dB	Mag.	Ang.	
1950	0.32	0.274	97.1	0.04
2350	0.40	0.253	124.1	0.03
2600	0.40	0.235	134.9	0.04
2700	0.44	0.249	148.3	0.03

Notes:

1. The Fmin values are based on noise figure measurements at multiple input impedances using Focus source pull test system. From these measurements a true Fmin is calculated.
2. Scattering and noise parameters are measured on coplanar waveguide made on 0.010 inch thick ROGER 4350. The input reference plane is at the end of the RFinput pin and the output reference plane is at the end of the RFoutput pin as shown in Figure 7.
3. Idd can be obtained by varying the Vg1/Vg2. Refer to figure 7.

Table 7. Typical Scattering Parameters, Vdd = 4.8 V, Idd = 55 mA

LNA SPAR (100 MHz – 20 GHz) The S-parameter are for single amplifier.

Freq (GHz)	S11 (dB)	S11 (ang)	S21 (dB)	S21 (ang)	S12 (dB)	S12 (ang)	S22 (dB)	S22 (ang)
0.1	-0.528	-12.397	32.100	165.000	-53.813	83.696	-1.030	-6.482
0.5	-2.941	-50.010	28.795	117.000	-42.505	61.680	-1.961	-29.310
0.7	-4.311	-61.514	26.800	101.931	-40.400	57.614	-2.290	-38.714
0.9	-5.614	-71.009	25.600	88.682	-39.000	54.200	-2.540	-48.109
1.0	-6.097	-74.603	24.690	82.909	-38.410	52.829	-2.614	-52.772
1.5	-8.113	-88.515	22.100	58.370	-36.100	46.445	-2.900	-76.330
1.7	-8.643	-94.117	21.200	49.166	-35.500	43.500	-2.992	-86.734
1.9	-9.050	-99.119	20.400	40.481	-34.900	41.138	-3.010	-97.019
2.0	-9.190	-102.000	19.980	36.080	-34.680	39.720	-3.012	-102.000
2.5	-9.520	-113.000	18.000	14.975	-33.700	34.200	-2.938	-129.000
3.0	-9.400	-121.000	16.100	-4.744	-33.100	29.390	-2.723	-155.299
3.5	-8.927	-129.000	14.400	-23.770	-32.600	28.565	-2.427	179.651
4.0	-8.320	-136.000	12.600	-42.140	-31.900	27.520	-2.060	156.000
4.5	-7.734	-143.000	10.900	-59.645	-31.000	27.600	-1.720	134.551
5.0	-7.280	-150.499	9.295	-76.500	-29.700	26.300	-1.430	114.501
5.5	-6.805	-160.000	7.645	-92.555	-28.200	23.590	-1.180	96.890
6.0	-6.498	-169.000	5.934	-108.000	-28.300	9.566	-1.160	78.240
7.0	-5.230	169.000	2.363	-135.699	-26.400	5.120	-0.705	52.430
8.0	-3.742	153.000	-0.400	-159.000	-24.120	-5.200	-0.498	33.500
9.0	-2.821	141.000	-2.808	175.000	-22.100	-21.300	-1.329	9.084
10.0	-2.430	124.000	-6.160	162.000	-21.600	-27.800	-3.530	4.510
11.0	-1.649	99.880	-7.440	132.000	-19.300	-48.610	-0.364	-17.210
12.0	-1.140	79.480	-11.000	106.000	-19.600	-65.620	-0.354	-30.020
13.0	-0.617	54.600	-12.700	83.870	-18.200	-77.170	-0.071	-27.430
14.0	-0.206	37.860	-14.100	52.560	-16.900	-96.040	-0.067	-45.840
15.0	-0.084	33.750	-14.500	27.550	-16.600	-104.000	-1.130	-72.650
16.0	-0.231	7.644	-14.400	-39.900	-9.988	-128.600	-0.611	-89.560
17.0	-2.473	-14.270	-13.400	-68.110	-10.700	-147.000	-0.359	-101.000
18.0	-2.536	-31.720	-17.200	-107.200	-10.600	168.000	-1.608	-111.000
19.0	-4.050	-54.900	-13.500	-158.000	-12.600	153.000	-3.342	-94.280
20.0	-7.930	-48.600	-16.300	158.000	-13.000	100.000	-5.330	-133.000

Table 8. Typical Noise Parameters, for single amplifier, Vdd = 4.8 V, Idd = 55 mA

Freq MHz	Fmin dB	Γ_{opt} Mag.	Γ_{opt} Ang.	$R_{n/50}$
1950	0.32	0.222	97.2	0.03
2350	0.39	0.226	127.5	0.03
2600	0.39	0.211	138.3	0.04
2700	0.42	0.223	152.6	0.03

Notes:

1. The Fmin values are based on noise figure measurements at multiple input impedances using Focus source pull test system. From these measurements a true Fmin is calculated.
2. Scattering and noise parameters are measured on coplanar waveguide made on 0.010 inch thick ROGER 4350. The input reference plane is at the end of the RFinput pin and the output reference plane is at the end of the RFoutput pin as shown in Figure 7.
3. Idd can be obtained by varying the Vg1/Vg2. Refer to figure 7.

Table 9. Typical Scattering Parameters, Vdd = 4.8 V, Idd = 75 mA

LNA SPAR (100 MHz – 20 GHz) The S-parameter are for single amplifier.

Freq (GHz)	S11 (dB)	S11 (ang)	S21 (dB)	S21 (ang)	S12 (dB)	S12 (ang)	S22 (dB)	S22 (ang)
0.1	-0.566	-12.697	33.000	164.000	-54.687	69.699	-1.100	-6.283
0.5	-3.221	-49.810	29.300	115.951	-42.890	62.495	-2.050	-29.010
0.7	-4.672	-60.507	27.200	99.986	-40.700	58.714	-2.369	-38.307
0.9	-5.972	-69.209	26.000	87.582	-39.200	55.764	-2.591	-47.518
1.0	-6.464	-72.403	24.990	81.809	-38.610	54.249	-2.673	-52.272
1.5	-8.421	-85.015	22.400	57.855	-36.200	47.570	-2.930	-75.630
1.7	-8.932	-90.217	21.500	48.683	-35.500	44.549	-3.012	-86.051
1.9	-9.320	-94.919	20.700	40.181	-34.900	42.062	-3.032	-96.319
2.0	-9.460	-97.320	20.300	35.780	-34.620	40.580	-3.042	-102.000
2.5	-9.740	-108.000	18.300	14.975	-33.700	34.125	-2.968	-129.000
3.0	-9.560	-117.000	16.400	-4.591	-33.100	29.200	-2.743	-155.000
3.5	-9.003	-124.000	14.700	-23.470	-32.700	28.165	-2.447	-180.000
4.0	-8.340	-131.399	12.900	-41.740	-32.100	27.200	-2.090	157.000
4.5	-7.700	-138.000	11.200	-59.090	-31.200	27.810	-1.750	135.000
5.0	-7.195	-146.499	9.590	-75.900	-29.900	26.700	-1.455	115.002
5.5	-6.700	-156.000	7.935	-91.755	-28.445	24.600	-1.190	97.290
6.0	-6.398	-165.000	6.230	-107.599	-28.440	10.500	-1.174	78.540
7.0	-5.150	172.000	2.653	-134.699	-26.500	6.132	-0.714	52.630
8.0	-3.662	155.000	-0.109	-158.000	-24.200	-4.154	-0.508	33.700
9.0	-2.741	143.000	-2.518	176.000	-22.100	-20.300	-1.319	9.373
10.0	-2.340	126.000	-5.890	163.000	-21.700	-27.100	-3.540	4.150
11.0	-1.580	101.900	-7.131	134.000	-19.300	-47.810	-0.372	-17.010
12.0	-1.092	80.980	-10.700	109.000	-19.700	-64.820	-0.352	-29.900
13.0	-0.586	55.970	-12.400	87.340	-18.200	-76.300	-0.070	-27.230
14.0	-0.173	39.100	-13.800	56.960	-17.000	-95.100	-0.068	-45.640
15.0	-0.064	35.050	-14.400	32.650	-16.800	-102.000	-1.130	-72.350
16.0	-0.187	10.140	-14.700	-33.560	-9.962	-127.000	-0.571	-89.360
17.0	-2.433	-11.370	-13.700	-61.810	-10.630	-145.000	-0.369	-101.000
18.0	-2.310	-29.300	-17.700	-97.240	-10.580	170.000	-1.528	-111.000
19.0	-3.698	-53.710	-13.500	-155.000	-12.200	154.000	-3.353	-94.380
20.0	-7.630	-49.500	-16.400	161.000	-12.700	102.000	-5.380	-134.000

Table 10. Typical Noise Parameters, for single amplifier, Vdd = 4.8 V, Idd = 75 mA

Freq MHz	Fmin dB	Γ_{opt} Mag.	Γ_{opt} Ang.	$R_{n/50}$
1950	0.33	0.198	101.8	0.03
2350	0.40	0.200	131.2	0.03
2600	0.41	0.189	143.1	0.04
2700	0.44	0.196	155.6	0.04

Notes:

1. The Fmin values are based on noise figure measurements at multiple input impedances using Focus source pull test system. From these measurements a true Fmin is calculated.
2. Scattering and noise parameters are measured on coplanar waveguide made on 0.010 inch thick ROGER 4350. The input reference plane is at the end of the RFinput pin and the output reference plane is at the end of the RFoutput pin as shown in Figure 7.
3. Idd can be obtained by varying the Vg1/Vg2. Refer to figure 7.

BALANCED MODE APPLICATION

Electrical Specifications

$T_A = 25^\circ\text{C}$, $V_{dd1} = V_{dd2} = 4.8\text{V}$ at $R_{bias} = 1\text{Kohm}$, RF performance at 2600 MHz, CW operation unless otherwise stated.

Symbol	Parameter and Test Condition	Units	Typ.
Vdd	Supply Voltage per amplifier	V	4.8
Idd	Supply Current per amplifier	mA	53
Gain	Gain	dB	17.8
NF	Noise Figure	dB	0.68
OP1dB	Output Power at 1dB Gain Compression	dBm	20.6
IIP3	Input Third Order Intercept Point	dBm	19.4
S11	Input Return Loss, 50 Ω source	dB	-32.3
S22	Output Return Loss, 50 Ω load	dB	-18.4
S12	Reverse Isolation	dB	-33

Balanced Amplifier Demo Board Layout

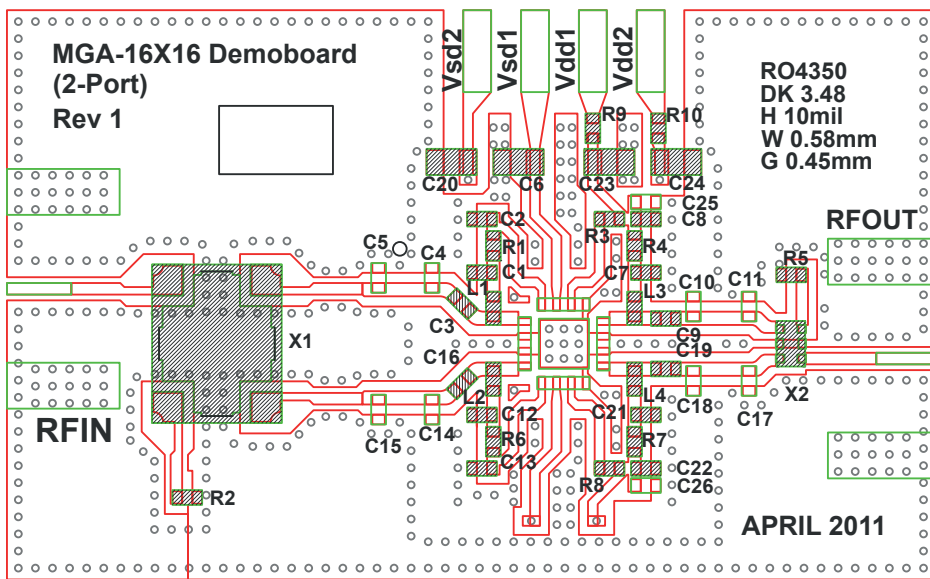

Figure 18. Balanced Amplifier Demo Board Layout Diagram

Notes:

1. Recommended PCB material is 10 mils Rogers RO4350.
2. Suggested component values may vary according to layout and PCB material.
3. Input board loss at 2600 MHz is 0.256 dB.

Balanced Amplifier Demo Board Schematic

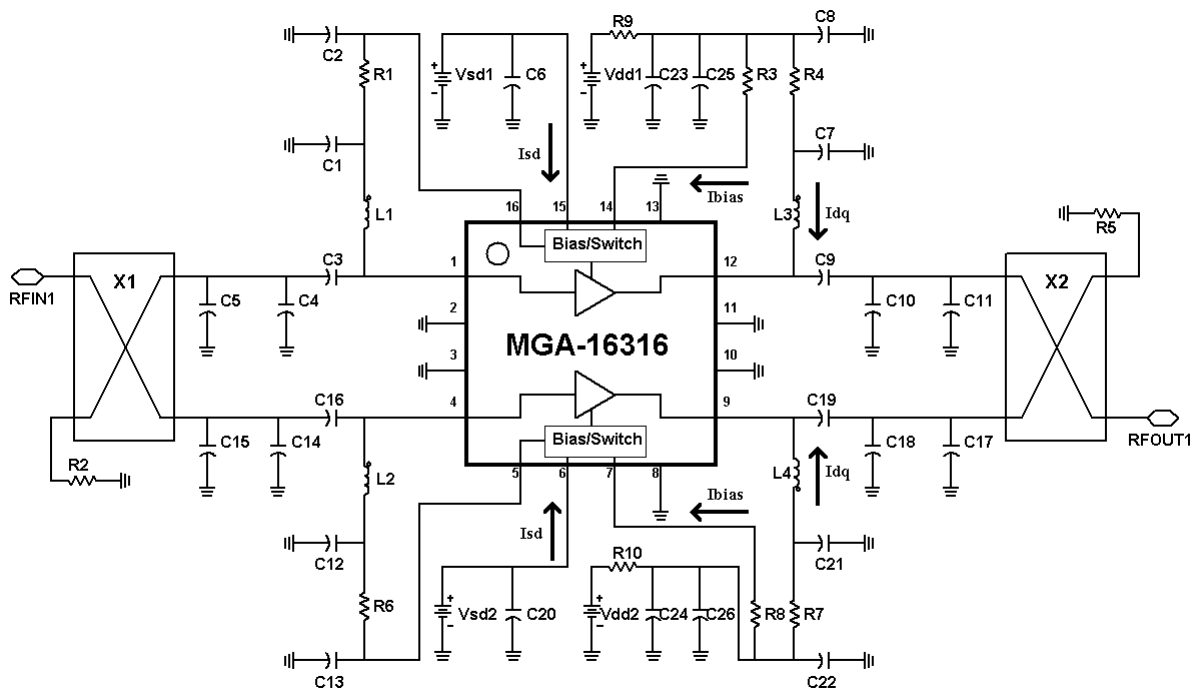

Figure 19. Balanced Amplifier Demo Board Schematic

Table 11. Component list for 2600 MHz matching

PART	Size	Value	Detail Part Number
C1, C12	0201	10 pF	GRM0335C1H100GD01
C2, C8, C13, C22	0402	0.1 μ F	GRM155R71C104KA88D
C9, C19	0201	1000 pF	GRM033R11E102KA01
C3, C16	0201	33 pF	GJM0335C0J330GB01
C6, C20, C23, C24	0805	4.7 μ F	GRM21BR61E475KA12
C7, C21	0201	15 pF	GRM0335C1H150GD01
C4, C5, C10, C11, C14, C15, C17, C18, C25, C26	0402	NOT USED	
L1, L2	0603	10 nH	LQW18AN10NG00D
L3, L4	0603	6.8 nH	LQW18AN6N8C00D
R1, R4, R6, R7	0402	0 ohm	RK73Z1ETTP
R3, R8	0402	1 kohm	RK73B1ETTP102J
R9, R10	0402	10 ohm	RK73B1ETTP100J
R2, R5	0402	51 ohm	RK73B1ETTP101J
X1	-	-	X3C26P1-03S
X2	-	-	C2327J5003AHF

Typical 2600 MHz RF Performance Plots on Balanced Mode

RF performance at $T_A = 25^\circ\text{C}$, $V_{dd1} = V_{dd2} = 4.8\text{V}$, $I_{dd1} = I_{dd2} = 53\text{mA}$, LNA mode, measured on demo board in Figure 18. Signal is CW unless stated otherwise. Application Test Circuit is shown in Figure 19 and Table 1. IIP3 test condition: FRF1-FRF2 = 1 MHz with input power of -20 dBm per tone.

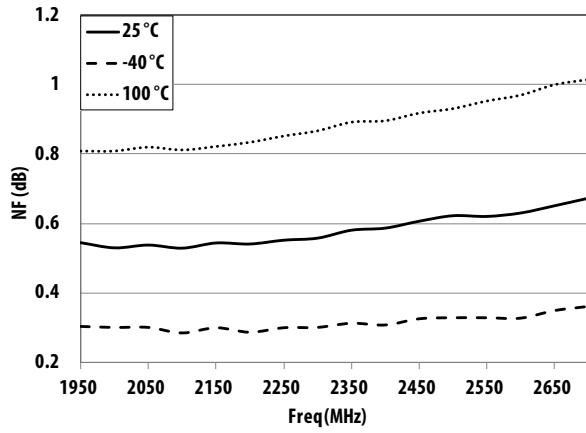

Figure 20. NF vs Frequency vs Temperature^[1]

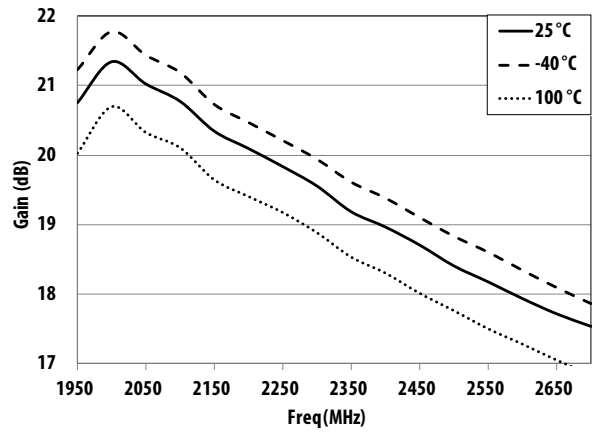

Figure 21. Gain vs Frequency vs Temperature

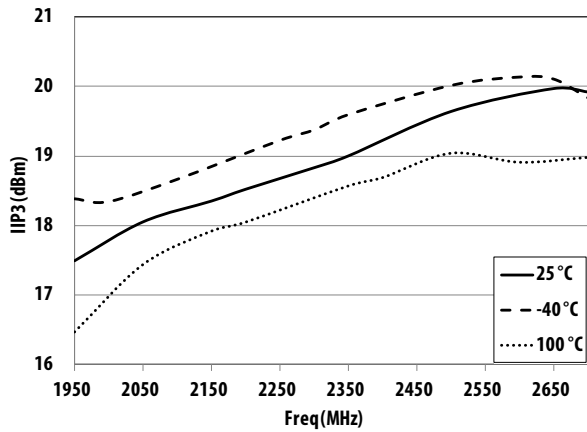

Figure 22. IIP3 vs Frequency vs Temperature

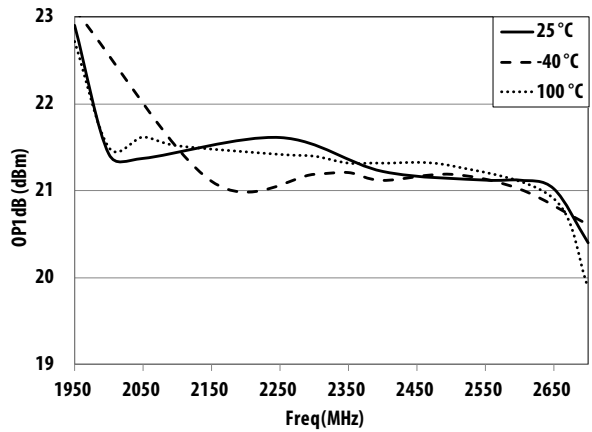

Figure 23. OP1dB vs Frequency vs Temperature

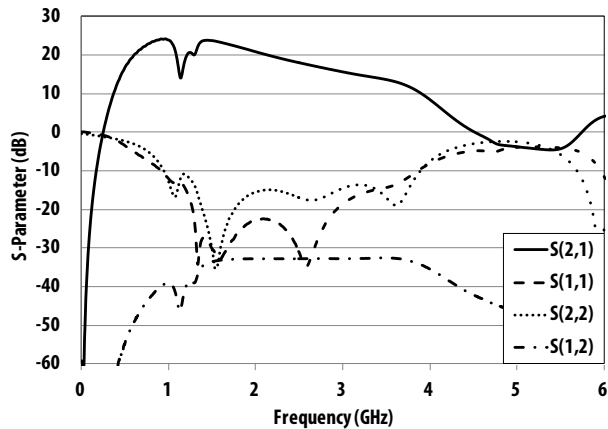

Figure 24. Input Return Loss, Output Return Loss, Gain, Reverse Isolation vs Frequency

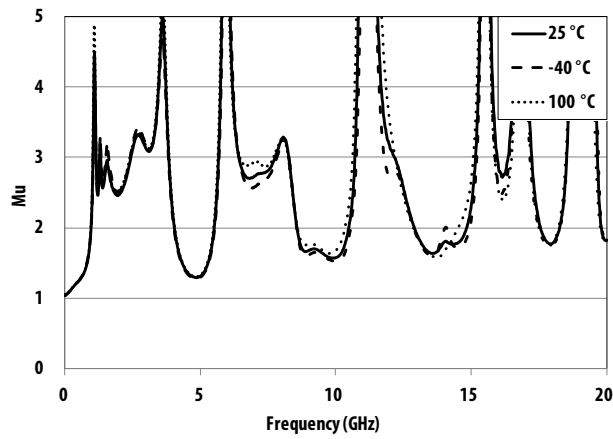

Figure 25. Mu stability factors vs Frequency vs Temperature

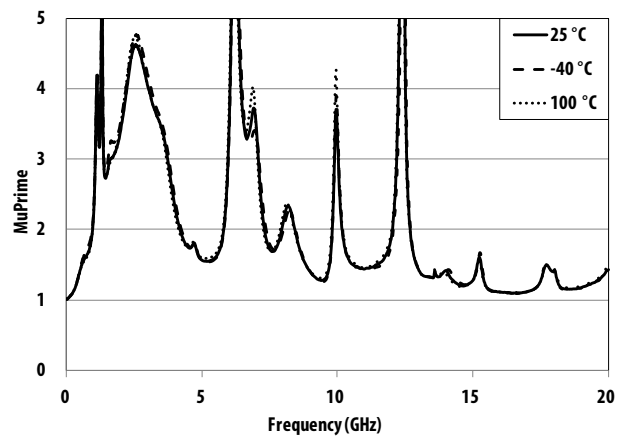

Figure 26. Mu' stability factors vs Frequency vs Temperature

Note:

1. Circuit trace losses for NF have been de-embedded from measurements above.

Part Number Ordering Information

Part Number	No. of Devices	Container
MGA-16316-BLKG	100	Antistatic Bag
MGA-16316-TR1G	1000	7" Reel

Package Dimensions

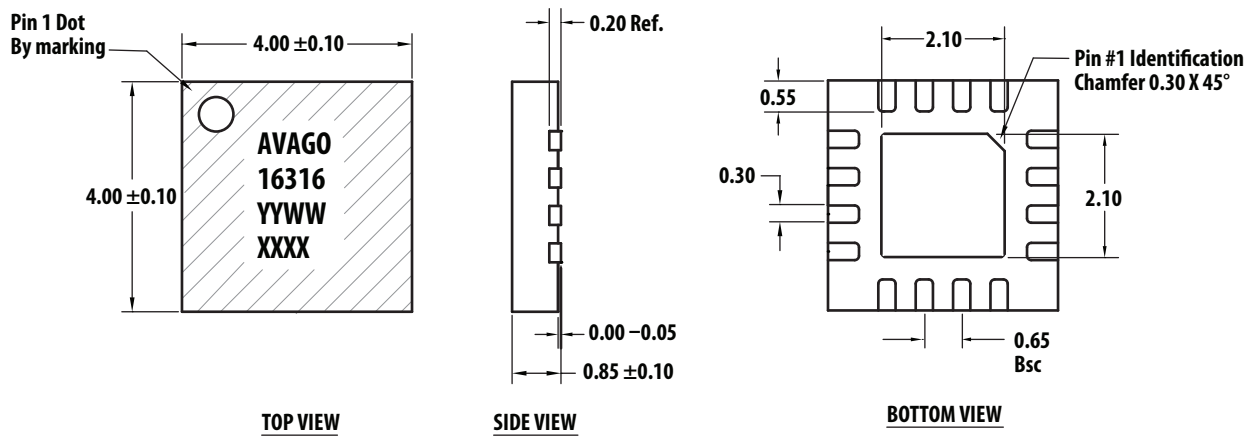

Recommended PCB Land Pattern and Stencil Design

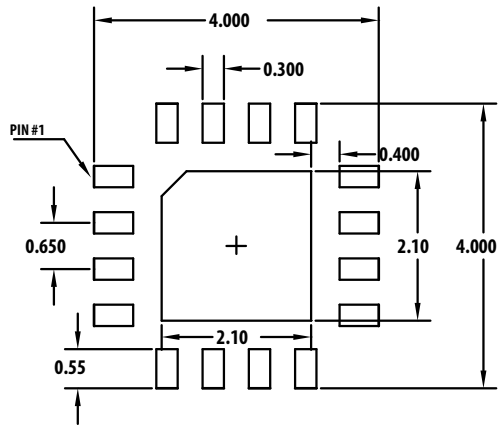

Land Pattern

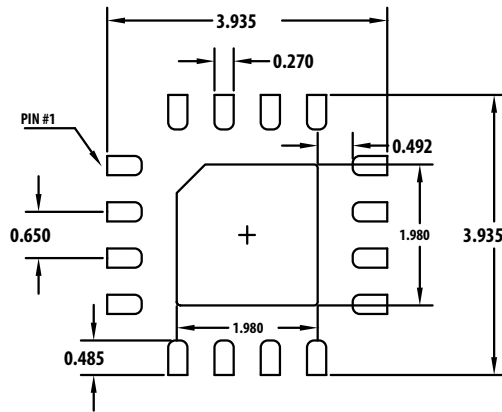

Stencil Opening

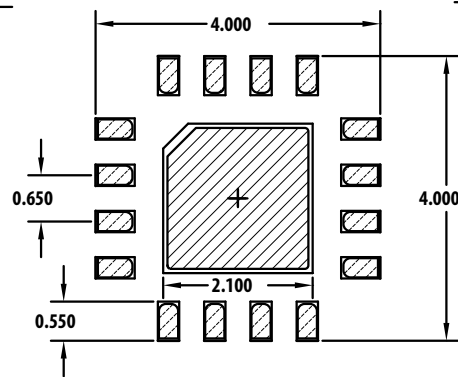

Combination of Land Pattern & Stencil Opening

Note:
 1. ALL DIMENSIONS ARE IN MILLIMETERS
 2. 4mil stencil thickness is recommended

Device Orientation

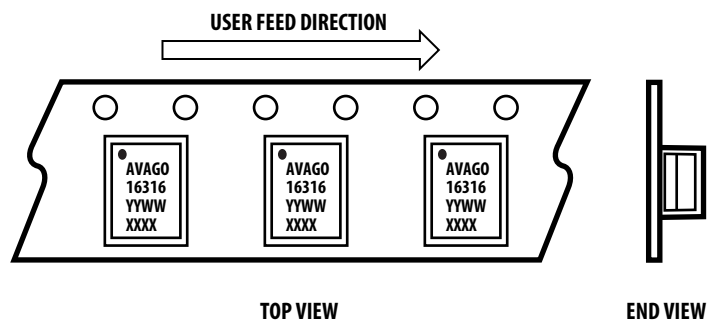
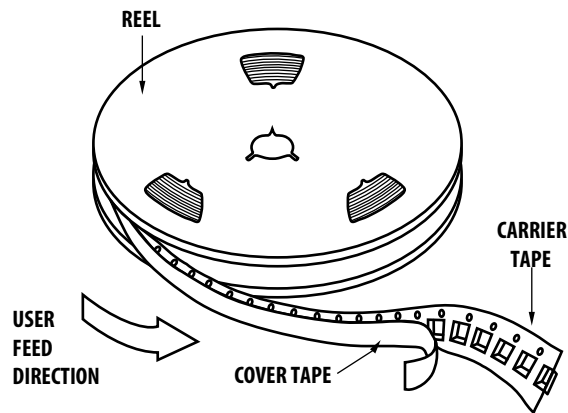

Tape Dimensions

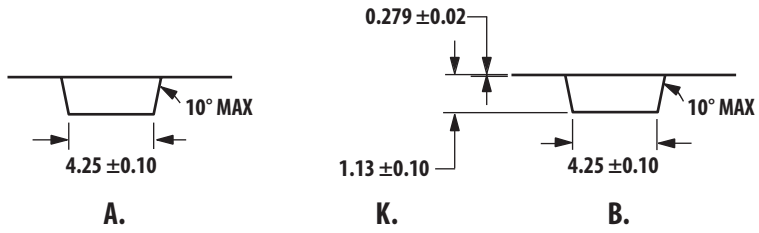
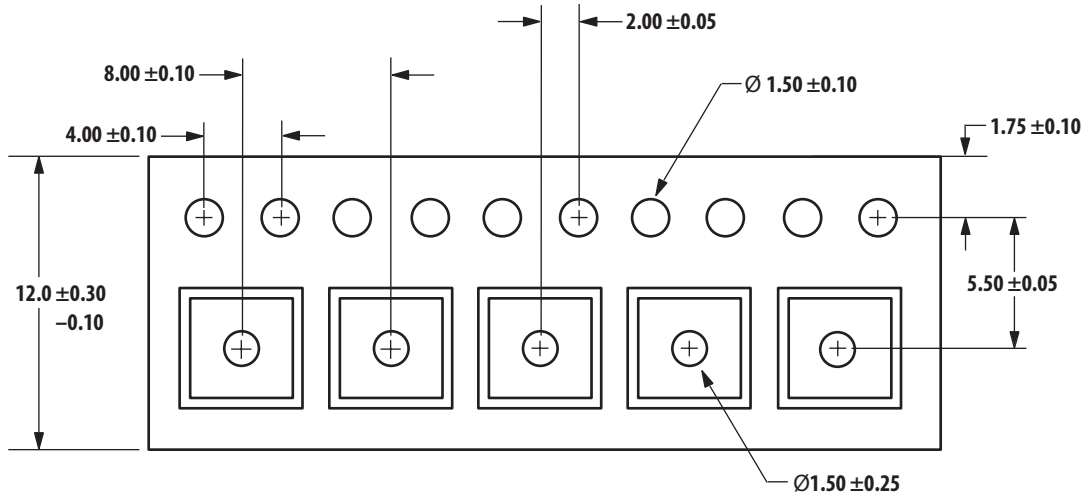

Reel Dimensions – 7 inch

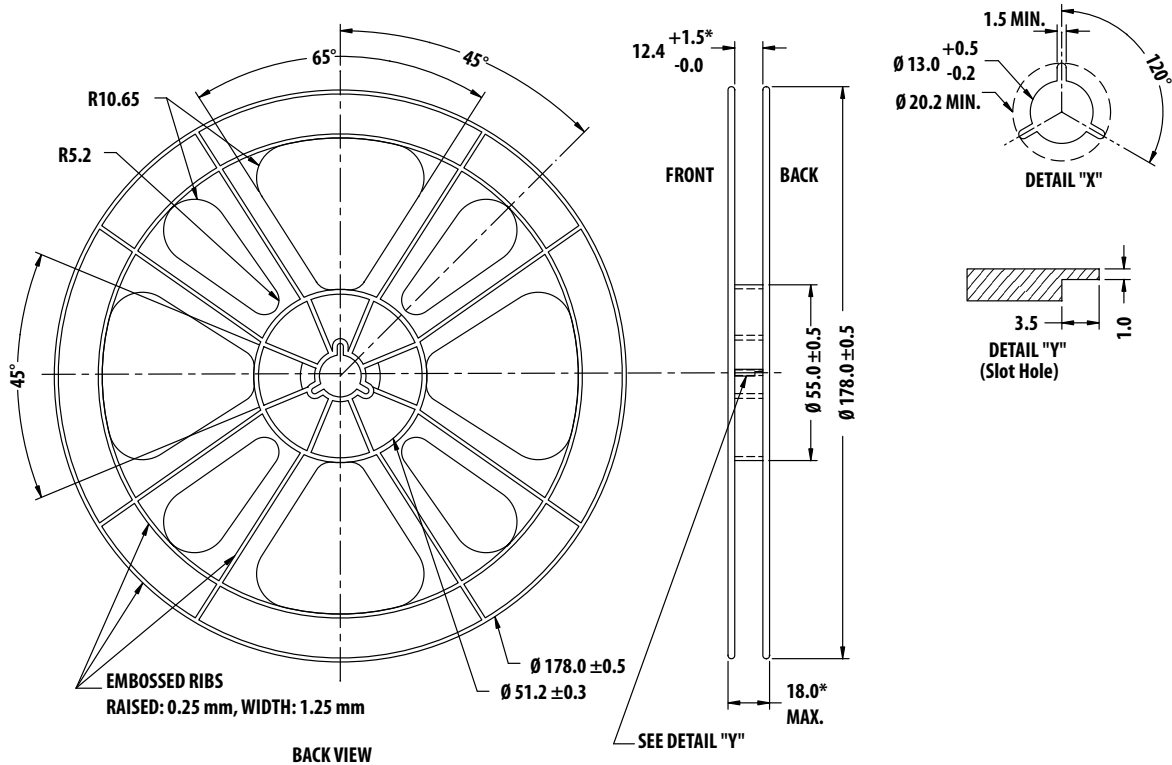
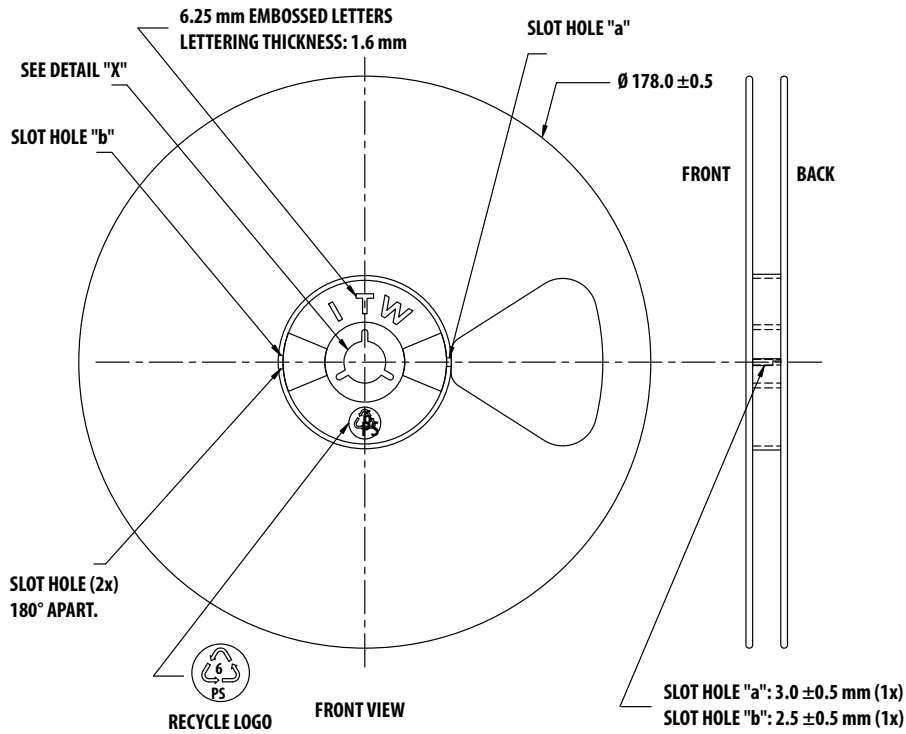

For product information and a complete list of distributors, please go to our web site: www.avagotech.com

Avago, Avago Technologies, and the A logo are trademarks of Avago Technologies in the United States and other countries. Data subject to change. Copyright © 2005-2013 Avago Technologies. All rights reserved. AV02-3723EN - February 6, 2013



X-ON Electronics

Largest Supplier of Electrical and Electronic Components

Click to view similar products for [RF Amplifier](#) category:

Click to view products by [Broadcom](#) manufacturer:

Other Similar products are found below :

[A82-1](#) [BGA622H6820XTSA1](#) [BGA 728L7 E6327](#) [BGB719N7ESDE6327XTMA1](#) [HMC397-SX](#) [HMC405](#) [HMC561-SX](#) [HMC8120-SX](#)
[HMC8121-SX](#) [HMC-ALH382-SX](#) [HMC-ALH476-SX](#) [SE2433T-R](#) [SMA3101-TL-E](#) [SMA39](#) [A66-1](#) [A66-3](#) [A67-1](#) [A81-2](#) [LX5535LQ](#)
[LX5540LL](#) [MAAM02350](#) [HMC3653LP3BETR](#) [HMC549MS8GETR](#) [HMC-ALH435-SX](#) [SMA101](#) [SMA32](#) [SMA411](#) [SMA531](#)
[SST12LP19E-QX6E](#) [WPM0510A](#) [HMC5929LS6TR](#) [HMC5879LS7TR](#) [HMC1087F10](#) [HMC1086](#) [HMC1016](#) [SMA1212](#) [MAX2689EWS+T](#)
[MAAMSS0041TR](#) [MAAM37000-A1G](#) [LTC6430AIUF-15#PBF](#) [SMA70-2](#) [SMA4011](#) [A231](#) [HMC-AUH232](#) [LX5511LQ](#) [LX5511LQ-TR](#)
[HMC7441-SX](#) [HMC-ALH310](#) [XD1001-BD-000V](#) [A4011](#)