

# NET2280

## Features

### ■ Overview

- PCI v3.0 - 33 MHz, 32-Bit Bus
- Hi-Speed USB 2.0 Peripheral Port
- Integrated 8051 CPU @ 60 MHz
- 8K of Random Access Memory
- Descriptor based DMA Controllers (4) for automatic data transfers
- Low Power 0.25 $\mu$  process ideal for USB Bus Powered Operation
- Lead Free Packaging
- 14x14mm, 120 Pin TQFP Package

### ■ Conventional PCI Interface

- PCI v3.0 - 33 MHz, 32 Bit PCI Bus
- 3.3V interface with 5V tolerance for compatibility with both 3.3 and 5V PCI systems
- Plug into existing PCI based systems to instantly add a High Speed USB 2.0 Device Port
- PCI Host Option for simple PCI Adapter to USB Peripheral Conversions
- Straightforward PC Card to ExpressCard™ Conversions
- Mastering PCI Interface
- Optional PCI Arbiter included

### ■ Hi-Speed USB 2.0 Interface

- USB 2.0 Peripheral Interface
- Hi-Speed USB with Sustained Bandwidth of up to 40MBytes/sec (at 480 Mbps bursts)
- Backwards compatible to Full Speed USB connections
- USB Auto-Enumeration Technology
- Support for Bulk, Isochronous, and Interrupt Endpoints
- Integrated PHY



## PCI to USB 2.0 Hi-Speed Peripheral Controller

### Adding Hi-Speed USB 2.0 to Embedded PCI Designs

PLX Technology's NET2280 PCI to Hi-Speed USB 2.0 Peripheral Controller is designed for easy integration with existing PCI based systems and silicon. While there are many PCI based USB Hosts on the market, the NET2280 is one of the only PCI based USB Peripheral Controllers available. With the NET2280, adding a Hi-Speed USB Device port is just a matter of connecting the PCI signals with the same name together.

The PCI bus on the NET2280 can either be a PCI Host or a PCI Adapter. As a PCI Adapter, the NET2280 can fit into any standard PCI slot (3.3 or 5 Volts). This means that any system with a PCI bus can instantly add a USB 2.0 Peripheral Port in minutes. As the NET2280 is supported by several operating systems, additional software modification can be minimized.

As a PCI Host, the NET2280 can be used to convert existing PCI Cards or CardBus Adapters to stand alone USB Devices or ExpressCard Adapters. Rather than relying on a Host PC's PCI Chipset, the NET2280 has a built-in CPU, to configure and bring up a PCI device. Furthermore, the Auto-Enumeration Technology in the NET2280 allows the USB device to be enumerated by a USB Host without any interaction on the PCI side.

### Tuned for Performance

The NET2280 is designed for high performance transfers, with its USB port able to match the bandwidth of most PCI chips.

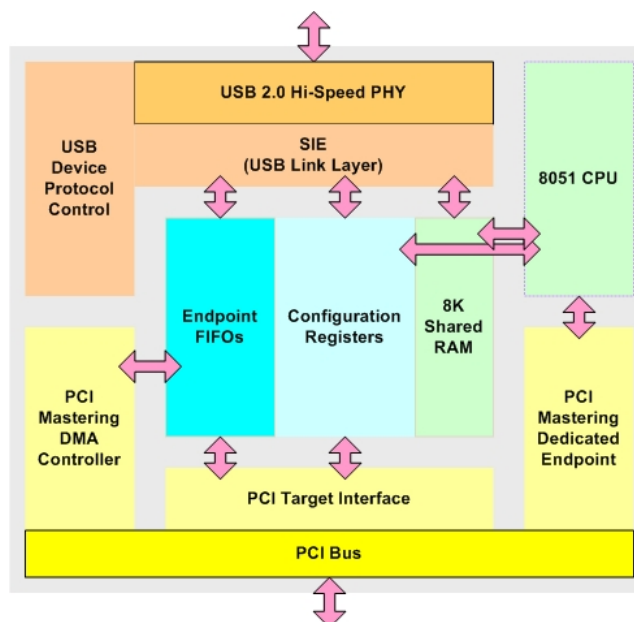

Four mastering, descriptor based DMA controllers, along with the NET2280's true FIFO structure, allow it to sustain transfers of up to 40 Mbytes / sec. Even at these speeds, and the full PCI bus running, the low power consumption of the NET2280 allows for its use in USB Bus-Powered devices.

Figure 1: NET2280 Block Diagram



## Design Applications

### Add Hi-Speed USB 2.0 to a Printer

The NET2280 can be used to easily add Hi-Speed USB 2.0 functionality to any PCI-based printer. The standard PCI interface of the NET2280 connects gluelessly to a printer's PCI bus backplane. Standard PCI registers allow the printer's CPU to easily configure and send data to and from the NET2280.

The NET2280 features six programmable USB endpoints for any combination of Interrupt, Isochronous, and Bulk data transfers. This allows printer applications to transfer different data (such as diagnostic or critical print data) through different endpoints to improve quality of service and ease of design.

PLX provides device firmware to configure the NET2280 to resemble a standard USB Printer Class device. With the USB Printer Class firmware, these devices can be recognized by PCs without any additional host-side drivers.

In these applications, the integrated CPU is usually not needed.

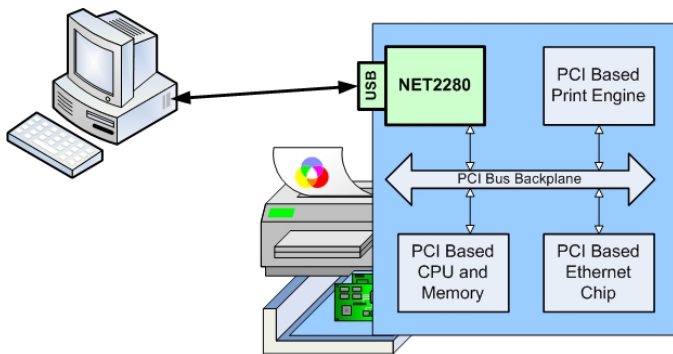

Figure 2: Converting a PCI-Based Printer to USB

## Migrate PCI and CardBus Designs to USB

The NET2280 is designed to easily convert existing PCI Cards or CardBus Adapters to stand alone USB Devices. Since both PCI and CardBus chips are based around the standard PCI protocol, the NET2280 connects gluelessly with them.

Instead of a PCI Host Chipset and BIOS on a PC configuring the PCI/CardBus silicon, the NET2280 can itself act as the PCI Host, with configuration information coming from its internal 8051 CPU or from the USB Host. Auto-Enumeration Technology allows a standard USB Host to detect this new USB device even if no firmware has been run. This means that firmware can actually be downloaded to the USB device after initial boot-up.

The NET2280 includes PCI clock, reset, interrupt, and arbitration pins to compensate for the other components usually found in a typical PCI Host environment.

## The NET2280 Reference Design Kit

The NET2280-RDK includes a PCI Board that easily plugs into any standard PCI slot (3.3V or 5V). This board also includes an optional PCI slot for plugging other PCI boards into the RDK board itself. That would be for those applications where the NET2280 will be the PCI Host.

Both USB Host and Peripheral side software is included with the NET2280-RDK. The Host side software consists of generic USB client drivers and several test and development applications. The peripheral side firmware is used to configure the NET2280 to resemble a standard USB class device (like a printer or mass storage device) for which no USB Host driver will need to be written. For custom, vendor-specific applications, the Firmware API is provided to abstract USB operation to standardized function calls. While this software is available for various operating systems, it is written in standard C with portability in mind. An included porting guide aids USB developers through the entire porting process.



PLX Technology, Inc.  
870 Maude Ave.  
Sunnyvale, CA 94085 USA  
Tel: 1-800-759-3735  
Tel: 1-408-774-9060  
Fax: 1-408-774-2169  
Web Site: [www.plxtech.com](http://www.plxtech.com)

## Product Ordering Information

Part Number	Description
NET2280REV1A-LF	PCI to USB 2.0 Hi-Speed Peripheral Controller
NET2280RDK	NET2280 Reference Design Kit
NET2280EVB	NET2280 Adapter Card
NET2280EVB-SW	NET2280 Adapter Card with Software

Please contact your local PLX sales representative for ordering information.

© 2005 PLX Technology, Inc. All rights reserved. PLX and the PLX logo are registered trademarks of PLX Technology, Inc. All other product names that appear in this material are for identification purposes only and are acknowledged to be trademarks or registered trademarks of their respective companies. Information supplied by PLX is believed to be accurate and reliable, but PLX Technology, Inc. assumes no responsibility for any errors that may appear in this material. PLX Technology, Inc. reserves the right, without notice, to make changes in product design or specification.

## X-ON Electronics

Largest Supplier of Electrical and Electronic Components

*Click to view similar products for [PCI Interface IC category](#):*

*Click to view products by [Broadcom manufacturer](#):*

Other Similar products are found below :

[PI7C8150BMA](#) [CA91L8260B-100CE](#) [PI3PCIE3442AZHEX](#) [PI7C9X2G304ELQZXAEX](#) [CH382L](#) [XIO2213BIZAY](#) [PM8531B-F3EI](#)  
[PI7C9X118SLFDE](#) [PI7C8150BNDE](#) [PI7C9X20505GPBNDE](#) [PM8562B-F3EI](#) [PM8576B-FEI](#) [PM8574B-FEI](#) [PCA9515ADP](#)  
[PI7C8140AMAE](#) [PM8536B-FEI](#) [DS160PR412RUAT](#) [DS160PR421RUAR](#) [PCI2040PGE](#) [PCI2050BIPDV](#) [PCI2050BPDVG4](#) [PCI2250PCM](#)  
[PCI2250PGF](#) [XIO1100ZGB](#) [PCA9515DP](#) [PCX107AVZFU100LC](#) [PI3PCIE3212ZBEX](#) [89H32T8G2ZCBLG](#) [89HPES12NT3ZBBCG](#)  
[PI7C9X113SLFDE](#) [PM8533B-F3EI](#) [89HPES12N3AZGBCGI](#) [PI7C8150BMAIE](#) [I-96](#) [PI3DBS16412ZHEX](#) [PI7C9X2G304ELZXAE](#)  
[PI7C9X2G304SVAFDEEX](#) [PI7C8150AMAE](#) [PM8572B-F3EI](#) [PI7C9X2G608ELBZXAE](#) [DS160PR412RUAR](#) [HD3SS3415RUAR](#)  
[TS2PCIE412RUAR](#) [XIO1100GGB](#) [XIO1100ZWSR](#)