

SAS3616W Tri-Mode I/O Controller (IOC)

16 PCIe® Lanes to 16-port SAS/SATA/PCIe IOC Featuring Tri-Mode SerDes Technology

Extending RAID and SAS Technology Leadership, Broadcom Introduces 16-port Tri-Mode SAS/SATA/PCIe IO Controller (IOC)

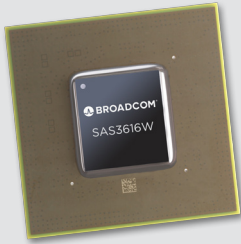

Applications

- Direct Attached SAS/SATA/PCIe controller solutions for server and storage applications
- Utilize PCIe attached SSDs with confidence of industry leading device management and error recovery

Key Features

- Multi-core processor
- Tri-Mode (SAS/SATA/PCIe) device ports
 - 16 port SAS+SATA controller
 - Supports 12, 6, and 3Gb/s SAS and 6, 3Gb/s SATA data transfer rates
 - Spread spectrum clocking
 - Supports SSP, SMP, STP and SATA protocols
 - SAS/SATA device support
 - Supports narrow and wide ports
 - T-10 End to End Data Protection (EEDP)
 - T-10 Optical Support

Broadcom Storage

Broadcom products serve four primary target markets: wireless communications, wired infrastructure, enterprise storage, and industrial. Broadcom offers the industry's broadest portfolio of storage solutions, backed by decades of experience and trusted by the world's leading server and storage suppliers. Broadcom provides the building blocks for storage solutions that help customers understand, prioritize, store and protect critical data.

The Broadcom 12Gb/s SAS portfolio includes MegaRAID® controller cards, Host Bus Adapters (HBAs), Advanced Software Options, and SAS storage ICs, including RAID-on-Chip (ROCs), I/O controllers and expanders.

Overview

The SAS3616W is the seventh generation of Serial Attached SCSI (SAS) controllers based on the industry-leading Fusion-MPT (Message Passing Technology) architecture. The SAS3616W host interface supports 16 PCI Express® (PCIe) lanes and complies with the PCIe 3.1 specification that extends the PCIe data rates up to 8.0 GT/s per lane, and is backwards compatible to the 5.0/2.5 GT/s. It also incorporates End-to-End CRC (ECRC) with Advanced Error Reporting (AER) in lane and polarity reversal, power management, hot plug support, and MSI/ MSI-X and legacy interrupt generation.

Key Features (con't)

- SAS 2.1 power management
- Supports up to 2,000 SAS/SATA devices
- Supports DataBolt bandwidth aggregation technology
- Up to 16 PCIe ports allow for 4 x4 ports, 8 x2 ports or 16 x1 ports configurations
- Separate Refclk Independent SSC (SRIS)
- PCIe application layer supports NVMe
- Up to 16 PCIe devices behind a switch supported
- PCIe 3.1 Host Interface
 - Supports x16, x8, x4, x2 PCIe lanes at a transfer rate up to 8.0 GT/s per lane, full duplex
 - Lane and polarity reversal
 - Supports End-to-End CRC (ECRC) and Advanced Error Reporting (AER)
 - Variable PCIe bandwidth negotiation
- Advanced power management support
 - Slumber and partial power mode support for SAS/SATA devices
 - Programmable SAS link power down
 - Variable PCIe bandwidth negotiation
- External memory interface support — SPI based Flash ROM

SFF-8680 “Tri-Mode Universal Bay” Topology

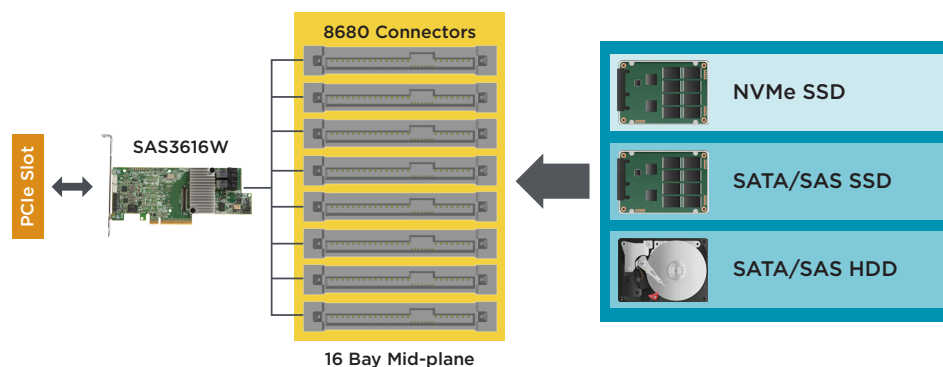

Broadcom Tri-Mode SerDes Technology enables seamless operation of PCIe, SAS, or SATA storage devices in a single drive bay. The introduction of PCIe devices executing NVMe to the existing SAS/SATA infrastructure makes industry standard hot-pluggable drive bays even more versatile. The sixteen-port Tri-Mode device interface provides SAS data transfer rates of 12, 6, and 3Gb/s per lane, or SATA at 6 and 3Gb/s data transfer rates per lane, or PCIe data transfer rates of 8, 5, and 2.5 Gb/s. The device automatically negotiates between the speeds and protocols. T-10 Data Protection Model (T-10 End to End Data Protection (EEDP) for early detection of and recovery from data corruption, and Spread Spectrum Clocking (SSC) for EMI reduction are supported. Additional features include SAS 2.1 power management and DataBolt Technology allowing users to take advantage of 12Gb/s speeds while utilizing existing 6Gb/s drives and backplanes.

The SAS3616W supports up to 16 direct attached PCIe devices and complies with PCIe 3.1 specifications. The device supports PCIe Dynamic Power allocation (DPA), ECRC, and AER with compatible devices.

The SAS3616W is ideal for the host or drive side connect for external storage controllers requiring a SAS/SATA interface. The SAS3616W can support up to 2,000 SAS or SATA devices and 8,000 outstanding IOs without external RAM and can achieve over 1 million IOs per second.

Broadcom provides a complete suite of industry standard operating system drivers. Broadcom also supports Virtual Operating Systems with device emulation and para-virtualization.

Key Features (con't)

- Communication interfaces
 - I²C interfaces for enclosure management services
 - UART and Ethernet interface for debug
- SFF-8485 compliant, SGPIO
- JTAG support
- Package (estimated) 28 mm

Fusion-MPT Architecture Overview

Fusion-MPT architecture marks the next generation of I/O architecture designed to deliver the highest performance available today while reducing time to market, integration, and certification time. Fusion-MPT devices are high performance, cost-effective protocol controllers that represent the newest system-level integration technology in intelligent I/O processors from Broadcom.

Figure 1: Direct Attach with PCIe, SAS, and SATA in servers with multiple drive bays without requiring an expander

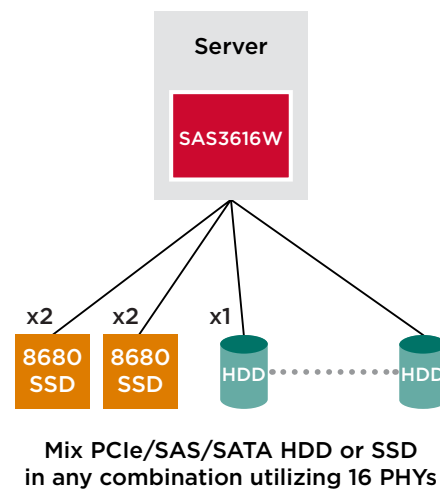

Figure 2: Direct Attached PCIe SSDs and SAS/SATA HDD combined with an expander to SAS/SATA HDDs

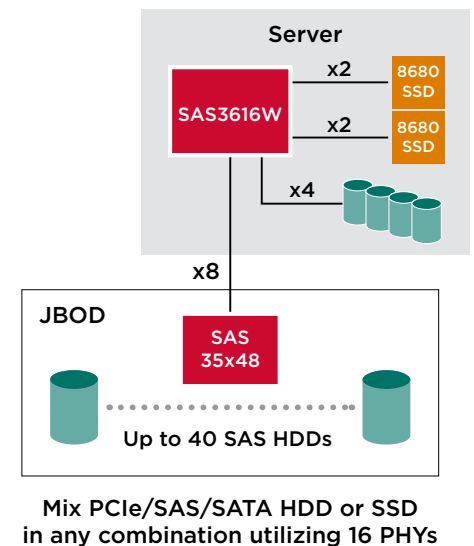
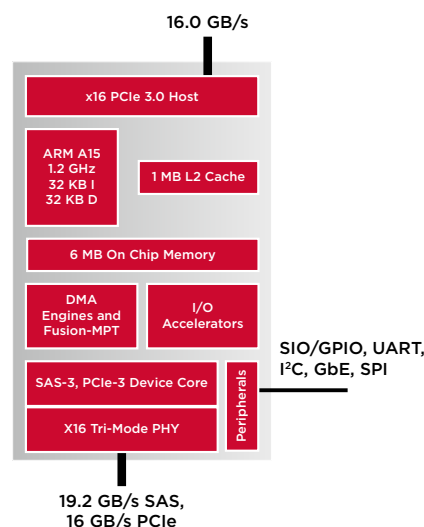

Figure 3: SAS3616W Block Diagram



X-ON Electronics

Largest Supplier of Electrical and Electronic Components

Click to view similar products for [I/O Controller Interface IC](#) category:

Click to view products by [Broadcom](#) manufacturer:

Other Similar products are found below :

[DSL4510 S R15X](#) [DSL5110 SR1TY](#) [EC-GAV](#) [SEC1210I-CN-02](#) [LPC47M107S-MS](#) [LPC47M102S-MS](#) [70M-OAC15A](#) [IS31IO7326-QFLS4-EB](#) [PM8001C-F3EI](#) [SLO24IRA](#) [LPC47B277-MS](#) [JHL8040R S LMN6](#) [BU92747GUW-E2](#) [IDC5Q](#) [FDC37B787-NS](#) [PCI1520IPDVEP](#) [MCP2140A-I/P](#) [CQM1-LK501](#) [IDC-24F](#) [OAC15](#) [ODC15](#) [OAC24](#) [OAC24A](#) [MCP2140A-ISO](#) [OAC5A](#) [IA82510PLC28IR2](#) [MAX5942BCSE+](#) [MAX5942ACSE+](#) [70G-IAC15](#) [70M-ODC15B](#) [DSL2310 S LJ3W](#) [JHL6240 S LLNG](#) [JHL6340 S LLSQ](#) [JHL7340 S LMHX](#) [JHL7440 S LMHZ](#) [JHL8540 S RH4Q](#) [JHL8340 S RH4N](#) [NH82801IB S LA9M](#) [MAX5940CESA+](#) [DS2488X+U](#) [DS8005-RJX+](#) [MCP2140A-ISS](#) [MCP2150-I/SS](#) [MCP2155-I/SS](#) [MCP2140AT-I/SS](#) [MCP2140-I/SS](#) [MAX5940DESA+](#) [ECE1200-I/LD](#) [LPC47N217N-ABZJ](#) [MCP2140-IP](#)