

承認書編號 NO: _____

TO: 格能 台照

承 認 書

APPROVAL SHEET

FOR SOLID AL. ELECTROLYTIC CAPACITORS

承 認 :
APPROVED BY :

料號 (Customer)	料號 (CapXon)	規格 Description D φ *L		加工形式 (mm)
	PX221M010E070P	220μF/10V	6.3X7	A

簽認後, 請送回一份。

PLEASE RETURN US ONE COPY YOUR SIGNED SPECIFICATION AFTER YOU APPROVED OF IT.

核 准
APPROVED BY: 

校 對
CHECKED BY: 

經 辦
DESIGNED BY: 



豐賓電子(深圳)有限公司
CAPXON ELECTRONIC (SHEN ZHEN) CO., LTD
廣東省深圳市光明新區公明鎮塘尾村

TANG WEI VILLAGE, GONG MING COUNTYGUANG MING HSIEN, SHEN ZHEN CITY, CHINA
TEL: 86-755-27177888
FAX: 86-755-27177802

CAPXON ELECTRONIC (SHEN ZHEN) CO.,LTD

FOR APPROVAL

Solid Aluminum Electrolytic Capacitors

PX Series

1. Electrolytic characteristics:

CAPXON P/N	Cap.(μ F)	Cap Tol. (%)	Rate W.V (VDC)	Surge Volt (VDC)	Max. D.F (tan δ)%	Ripple Current 100KHz/105 $^{\circ}$ C (mA)	Max.ESR 100KHz (m Ω)	Max. LC (μ A)	Operating Temp Range.($^{\circ}$ C)	Case Size D Φ * L (mm)
PX221M010E070P	220	-20~20	10	11.5	8	2690	20	300	-55~105	6.3X7

2. Compensation Factor of Ripple Current vs. Frequency:

Frequency \ Hz	120 \leq f<1K	1K \leq f<10K	10K \leq f<100K	100K \leq f<300K
Coefficient	0.05	0.3	0.7	1

3. Diagram of Dimensions: (Unit=mm)

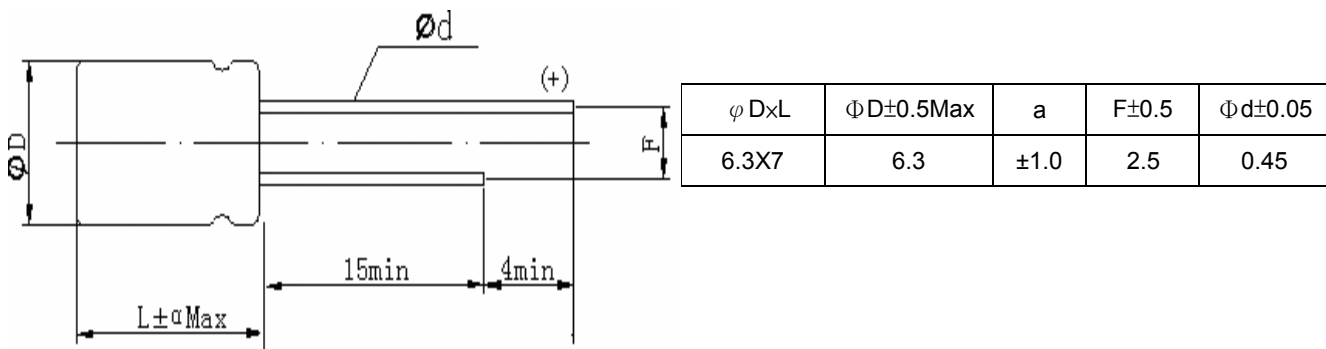

4. Remarks:

- 4.1 Leakage Current Test: $I \leq 300(\mu$ A) ,After 2 minutes with rated working voltage applied.
- 4.2 Operating temperature: -55 $^{\circ}$ C to +105 $^{\circ}$ C
- 4.3 Cap and Dissipation factor (D.F) Test: At +20 $^{\circ}$ C ,120Hz.
- 4.4 Endurance Test: At +105 $^{\circ}$ C ,at rated voltage for 2000Hrs.
- 4.5 Moisture Resistance Stored at 60 $^{\circ}$ C 、RH90~95% , for 1000Hrs.
- 4.6 Such spec. capacitors are just fit for this electric model , if you have some other application, please contact with us in advance.



Part Number System

When placing and order for Aluminum Electrolytic Capacitors. Please observe following Catalog Part Number format that describes.

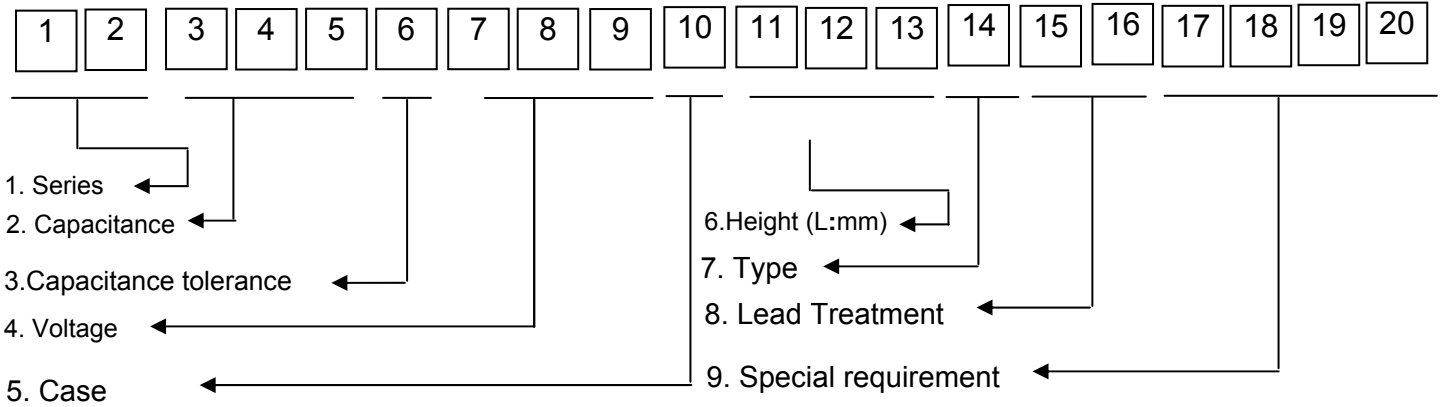

(1).Series

PL	PE	PM	PS	PH	PD	PU	PT	PV	PX	PF	PG	PR	PW
----	----	----	----	----	----	----	----	----	----	----	----	----	----

(2).Capacitance

Capacitance is show in microfarad (μF)

Capacitance (μF)	0.1	0.47	1	4.7	10	100	1000	10000
Code	0R1	R47	010	4R7	100	101	102	103

(3).Capacitance tolerance

Tolerance%	±5	±10	±20	±30	-10to+30	-10to+50	-10to+20	-10to100	0to+20	-30to+0	±15
Code	H	K	M	N	Q	T	V	W	Z	U	S
Tolerance%	0to+30	0to+40	0to+50	-5to+20	-8to+5	+5to+20	0to-20	-15to+20	-25to+20	-50to+0	-5to+30
Code	Y	X	A	J	E	I	B	P	L	O	C

For tolerance other than these and specified capacitance tolerance, please specify the value on the order sheet.

(4).Voltage (W.V)

Voltage (W.V)	2.5	4	6.3	10	16	20	25	35	50	100
Code	2R5	004	6R3	010	016	020	025	035	050	100

(5).Case (φD: mm)

Diameter	4	5	6.3	8	10
Code	B	C	E	F	G

(6). Height (L: mm)

Description	5	5.8	7	7.7	8	8.7	9	10.5	11	11.5	11.7	12.5
Code	050	058	070	077	080	087	090	105	110	115	117	125

(7). Type

Type	Polymer
Code	P

(8). Lead Treatment .

Description	Taping(Ammo Package)	Lead Cutting
Code	TA、TB、TC、TD、TE、TR.	CA

(9) Special & appearance requirement (the 17th, 18th, 19th, 20th code)

Code	Special	Code	Special	Code	request characteristic	Code	Special
A	Terminals of Snap-in	H	Height requirement	R	Ripple current	U	Package & label
B	Rubber	I	L.C.	S	Countermeasure		
C	Lead wire	K	Vent line	T	Temperature characteristic		
D	D.F.	L	Life	V	Vt, Electrolyte paper		
E	Electrolyte	N	Nude	M	Solder, technics, form, Case with stud		
F	Pitch	P	Sleeve, tray, print, PVC sleeve	Y	clip loop		
G	Fill glue	Q	Capacitance, CV, Break	Z	Impedance & ESR		

Remarks:

1. If it's without lead treatment & special requirement, after the 14th code is blank.
2. If it's with lead treatment & without require special requirement, the 17th, 18th, 19th, 20th code is blank.
3. If it's without lead treatment, but with special requirement, the 15th, 16th code filled with 0.
4. If it's without lead treatment, but with special requirement, also exceeds 4 kinds, keystone characteristic is 4 codes.
5. If it's with lead treatment, but with 1 special requirement, only remark 17th code, latter three codes is blank.
6. If it's with lead treatment, but with 1 special requirement, and it is different from former data, the 17th is 0, the 18th code is characteristic.

GUIDE TO APPLICATION

1. Maximum ripple current

- 1.1 Maximum RMS ripple current at +105 °C 100K Hz is given in the item1.
- 1.2 When capacitors are operated at temperatures other than +105 °C, and frequency other than 100KHz, the maximum RMS ripple currents must be multiple by the factors shown in below table.
 Compensation Factor of Ripple Current vs. Frequency:

Frequency / Hz	120≤f <1K	1K≤f <10K	10K≤f <100K	100K≤f <300K
Coefficient	0.05	0.3	0.7	1

- 1.3 Use a capacitor designed for higher rated ripple current than circuit ripple current ,The I peak value not exceed the verify rated ripple current value. The ripple current verify methods according to JIS C 5101-4 No.4.13.
 ☆ Note: Ripple current requires frequency correction.

2. Ripple voltage

Ripple voltage must not exceed the following:
 The sum of DC voltage and AC ripple voltage must not exceed the rated DC voltage. The DC voltage plus the peak AC voltage must not cause a voltage reversal more than 1.0 voltage.

3. Insulating

Solid aluminum electrolytic capacitors are covered with a plastic coated vinyl sleeve or the like unusual. And this sleeve is used for marking. When the internal element or the container is needed to be insulated, capacitors with special design for insulation requirement are recommended to be used.

4. Soldering

- 4.1 When soldering a printed circuit board with various components, too high soldering temperature or too long dipping times may cause secondary shrinking of the sleeve, which unnecessarily exposes the container. Soldering is allowed to perform at a temperature less than 260±5°C for less than 10±1 seconds. When soldering with a solder iron, the soldering conditions is 400±10°C for less than 5~6 seconds.
- 4.2 Soldering may melt or break the sleeve, if the sleeve is contacted with circuit patterns. To avoid this trouble, capacitors are recommended to be slightly apart from the circuit boards.

5. Vent

The capacitors may not be provided with a pressure resistive controlled safety vent formed on the bottom of the container.

6. High Altitude

These capacitors are capable of withstanding in transit conditions where storage temperature may range from -55 to+105°C and the altitude may reach 200,000 feet.

7. Cleaning agents

Halogenated hydrocarbon cleaning solvents are not recommended for use in cleaning capacitors supplied with exposed end seals. Whenever cleaning with a halogenated solvent is desired, capacitors should be ordered with an Epoxy-coated end seal.

8. Environment-friendly Policy

In the entire process of production, manufacture, packaging, storage or and transportation of the products, our company shall not violate any of the substances banned/restricted related requirements as set forth in the related the Environmental Protection Laws and Regulations RoHS.

9. Mounting and Installation design according to EIAJ RCR-2367 standards.

PERFORMANCE CHARACTERISTICS

1.Scope

Specification is applied for Single-ended lead, general purpose used Aluminum Electrolytic capacitor, used in communication equipment, switching power supplies, industrial measuring instruments, automotive application, etc.

2.Standard Test condition

Unless otherwise specified, all tests shall be performed at ambient temperature of $20\pm 2^{\circ}\text{C}$ and a relative humidity of $65\pm 5\%$.

3.Mechanical Requirement

According to JIS C 5101-4 No.4.4 methods,the test condition according as below:

A) Tensile

Apply a force as below for 10 ± 1 seconds in the direction of the axial each wire.

Diameter of terminal (mm)	Pull force(N $\pm 10\%$)
$0.35 < d \leq 0.5$	5(0.51Kg)
$0.5 < d \leq 0.8$	10(1.02Kg)
$0.8 < d \leq 1.25$	20(2.04Kg)
OTHER	40(4.08Kg)

B) Bending

Suspend weight corresponding to bending strength as below, and bend the body through 90° .Then, return it to the original position. Carry out similar operations in the opposite direction and count it as two cycles.

Diameter of terminal (mm)	Pull force(N $\pm 10\%$)	Bends
$0.35 < d \leq 0.5$	2.5N(0.26 Kg)	2
$0.5 < d \leq 0.8$	5 N(0.51 Kg)	2
$0.8 < d \leq 1.25$	10N(1.02 Kg)	2
OTHER	20N(2.04Kg)	2

Performance:The capacitors shall meet the following specification after A) or B) test.

Appearance : No cutting and slack of lead terminals.

4.Electrical Requirements

4.1 Operating Temperature and Rated Working Voltage Range

-55to+105 $^{\circ}\text{C}$

4.2 Capacitance Range and Tolerance(measured at 120Hz, +20 $^{\circ}\text{C}$)

-20~20%

4.3 Dissipation Factor(When measured at 120Hz, +20 $^{\circ}\text{C}$)

Please see it in the specifications for each series

4.4 DC Leakage Current

After DC voltage is applied to capacitors through the series protective resistor (1 K Ω). So that terminal voltage may reach the rated use voltage. The leakage current when measured in 2 minutes shall be below the value of the following equation.

$I \leq 300$ or the value in specification (μA)

I : Leakage Current. (μA)

C: Capacitance. (μF)

V: Rated DC Working Voltage. (V)

4.5 Load Life

According to JIS C 5101-4 No. 4.13 methods, capacitors shall be placed in an oven with application of the rated voltage for 2000 hours at the $105\pm 2^{\circ}\text{C}$, the characteristic shall meet the following requirements.

Capacitance Change : Within $\pm 20\%$ of initial value.

Dissipation Factor : Shall not increase more than 150% of the initial specified value.

Leakage Current : Shall be within the initial specified value.

ESR(100KHz) : Shall not increase more than 150% of the initial specified value.

Appearance : No leakage and undamaged.

4.6 Shelf life

According to JIS C 5101-4 No. 4.17 methods, after 1000 hours test at $+105^{\circ}\text{C}$ without rated working voltage applied, the characteristic shall meet the following requirements.

Capacitance Change : Within $\pm 20\%$ of initial value.

Dissipation Factor : Shall not increase more than 200% of the initial specified value.

Leakage Current : $I \leq 300$ (after voltage treatment) (μA)

I : Leakage Current. (μA)

C: Capacitance. (μF)

V: Rated DC Working Voltage. (V)

Voltage treatment : DC rated voltage is applied to the capacitors for 2minutes

Appearance : No leakage and undamaged.

4.7 Characteristics at high and Low temperature: According to JIS C 5101-4 No. 4.19 methods

Step	Temperature($^{\circ}\text{C}$)	Test Item	Characteristics
1	Normal temperature ($+20\pm 2$)	Capacitance※※ Tangent of loss angle※※ Impedance	For use as reference value
2	Lower category temperature (-55 ± 3)	Capacitance※※	$\Delta C/C \leq 20\%$ of value measured in Step 1
		Tangent of loss angle※※	≤ 2 times of the initial specified value
		Impedance	$Z_{-55^{\circ}\text{C}}/Z_{+20^{\circ}\text{C}} \leq 2$
3	Upper category temperature ($+105\pm 2$)	Capacitance※※	$\Delta C/C \leq 20\%$ of value measured in Step 1
		Tangent of loss angle※※	Shall be within the initial specified value
		Leakage current	≤ 12.5 times of the initial specified value.

Note: ※※ If applicable.

Capacitance and Tangent of loss angle at 120Hz

Impedance at 100KHz

4.8 Surge Voltage Test

According to JIS C 5101-4 No. 4.14 methods, after surge voltage applied at a cycling rate of 0.5 minute on and 5.5 minutes off for 1000 successive test cycles, the characteristic change shall meet the following requirements.

Capacitance Change : Within \pm 10% of initial value.

Dissipation Factor : Shall be within the initial specified value.

Leakage Current : Shall be within the initial specified value.

Appearance : No leakage and undamaged.

WV	2.5	4	6.3	10	16	20	25	35	50	63	80	100
SV	2.8	4.6	7.2	11.5	18.4	23	27.5	38.5	55	69.3	88	110

4.9 Vibration

According to JIS C 5101-4 No.4.8 methods, Use test frequency from 10- 55- 10Hz (Approximately 1 minute), 3 directions of X, Y and Z, each 2 hours, performance of parts shall not have changed, or breakage. the characteristic change shall meet the following requirements.

Capacitance Change : Within \pm 5% of initial value.

Dissipation Factor : Shall be within the initial specified value.

Leakage Current : Shall be within the initial specified value.

Appearance : No leakage and undamaged.

4.10 Solderability Test

According to JIS C 5101-4 No.4.6 methods, after the lead wire fully immersed in the solder for 2 ± 0.5 seconds at a temperature of $245\pm 5^{\circ}\text{C}$, the solder coating must be more than 95%(Flux: Rosin(JIS K 5902) // Ethanol(JIS K 8101);About 25wt.%). The characteristic change shall meet the following requirements.

Capacitance Change : Within \pm 5% of initial value.

Dissipation Factor : Shall be within the initial specified value.

Leakage Current : Shall be within the initial specified value.

4.11 Resistance to soldering heat

According to JIS C 5101-4 No.4.5 methods,the test condition according as below:

A) Solder bath method

Temperature: $260\pm 5^{\circ}\text{C}$

Duration: 10 ± 1 seconds

- Heat protector: using a thermal insulating screen of $1.5\text{mm}\pm 0.5\text{mm}$ thickness.

B) Soldering iron method

Temperature: $400\pm 10^{\circ}\text{C}$

Duration:5~6 seconds

- Heat protector: using a thermal insulating screen of $1.5\text{mm}\pm 0.5\text{mm}$ thickness.

Performance:The capacitors shall meet the following specification after A) or B) test.

Capacitance Change : Within \pm 5% of initial value.

Dissipation Factor : Shall be within the initial specified value.

Leakage Current : Shall be within the initial specified value.

Appearance : No leakage and undamaged.

4.12 Rapid change of temperature

According to JIS C 5101-4 No.4.7 methods, capacitor shall be placed in an oven, the conditions according as below:

Temperature	Time
(1) Rated low temperature(-55±3℃)	30 ± 3 Minutes
(2) Normal temperature(+25±5℃)	3 Minutes
(3) Rated high temperature(+105±5℃)	30 ± 3 Minutes
(4) Normal temperature(+25±2℃)	3 Minutes
(1) to (4) = 1 cycle, total 10 cycles	

The characteristic change shall meet the following requirements.

Capacitance Change : Within ±5% of initial value.

Dissipation Factor : Shall be within the initial specified value.

Leakage Current : Shall be within the initial specified value.

ESR : Shall be within the initial specified value.

Appearance : No leakage and undamaged.

4.13 Humidity Test

According to JIS C 5101-4 No.4.12 methods, capacitors shall be exposed for 1000 hours in an atmosphere of 90-95 % R.H. at 60±2 ℃,the characteristic change shall meet the following requirement.

Capacitance Change : Within ±20% of initial value.

Dissipation Factor : Shall be within 1.5 times of the initial specified value.

Leakage Current : Shall be Within the initial specified value.

ESR : Shall be within 1.5 times of the initial specified value.

Appearance : No leakage and undamaged.

5. Marking

All marking shall be legible and permanent.

- (1) Rated voltage:10V
- (2) Nominal capacitance:220 uF
- (3) Polarity (Cathode indicate)
- (4) Production date code:701
- (5) Series: PX
- (6) Logo of CapXon electronic co., ltd.
- (7) Marking color:BLUE

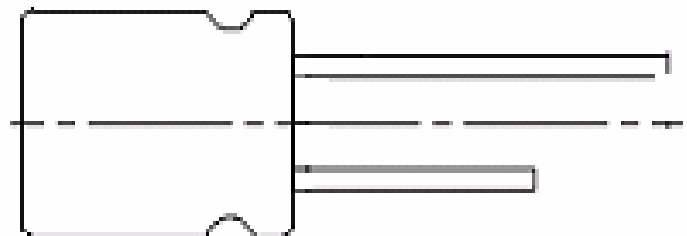
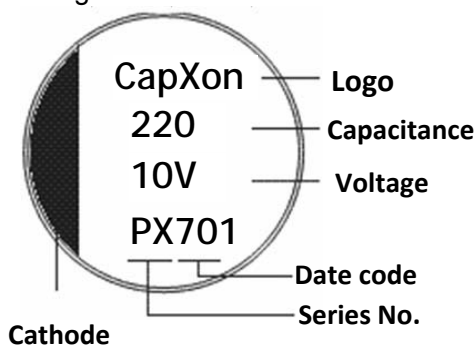

Note: (4) Production date code

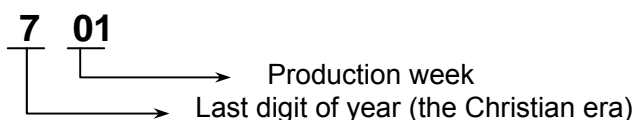

X-ON Electronics

Largest Supplier of Electrical and Electronic Components

Click to view similar products for [Aluminium Electrolytic Capacitors - Radial Leaded](#) category:

Click to view products by [Capxon](#) manufacturer:

Other Similar products are found below :

[LXY50VB4.7M-5X11](#) [RFO-100V471MJ7P#](#) [ECE-A1EGE220](#) [1814181](#) [NCD681K10KVY5PF](#) [NEV1000M25EF-BULK](#) [NEV100M35DC](#)
[NEV100M63DE](#) [NEV220M25DD-BULK](#) [NEV.33M100AA](#) [NEV4700M50HB](#) [NEV.47M100AA](#) [NEVH1.0M250AB](#) [NEVH3.3M250BB](#)
[NEVH3.3M450CC](#) [KME50VB100M-8X11.5](#) [SG220M1CSA-0407](#) [ES5107M016AE1DA](#) [ESX472M16B](#) [476CKH100MSA](#) [477RZS050M](#)
[UVX1V101KPA1FA](#) [UVX1V222MHA1CA](#) [KME25VB100M-6.3X11](#) [VTL100S10](#) [VTL470S10](#) [511D336M250EK5D](#) [052687X](#) [ECE-](#)
[A1CF471](#) [EKXG451ELL820MM30S](#) [686CKR050M](#) [NRE-S560M16V6.3X7TBSTF](#) [ERZA630VHN182UP54N](#) [UPL1A331MPH](#)
[NEV1000M6.3DE](#) [NEV100M16CB](#) [NEV100M50DD-BULK](#) [NEV2200M16FF](#) [NEV220M50EE](#) [NEV2.2M50AA](#) [NEV330M63EF](#)
[NEV4700M35HI](#) [NEV4.7M100BA](#) [NEV47M16BA](#) [NEV47M50CB-BULK](#) [NEVH1.0M350AB](#) [NEVH2.2M160AB](#) [NEVH3.3M350BC](#)
[TER330M50GM](#) [477KXM035MGBWSA](#)