

1S-Series

Miniature Rockers & Paddles

PRODUCT WEBPAGE

request sample, configure part

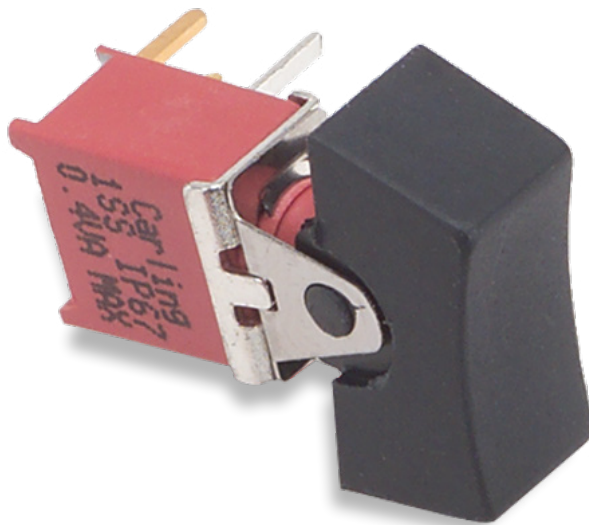
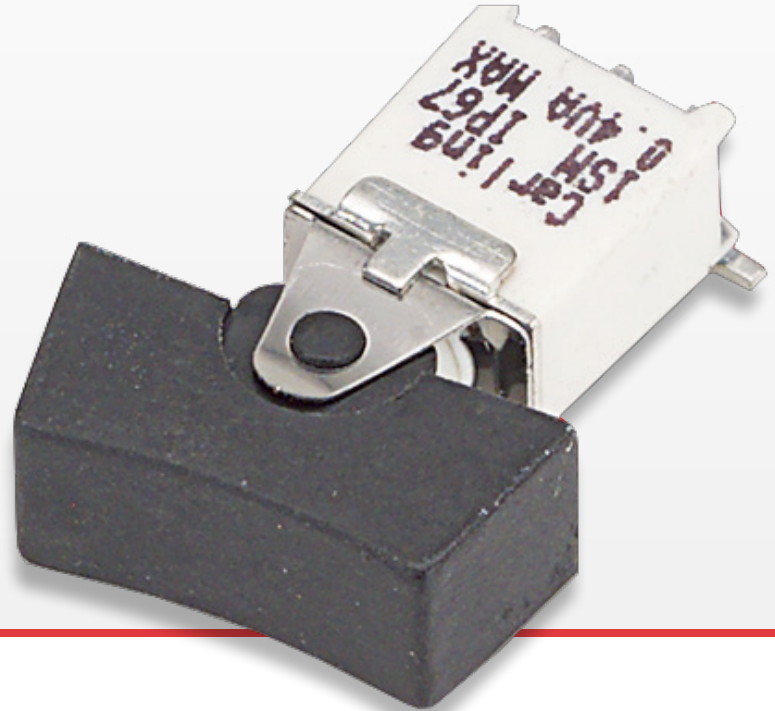

The 1S family of sub-miniature rocker switches is composed of three switch series; the 1S1-Series sub-miniature rocker switch, the 1SS-Series sealed sub-miniature rocker switch, and the 1SM-Series surface mount sealed sub-miniature rocker switch. All of these series offer a variety of ratings, circuits, contact materials, terminal platings, and actuator colors.

1-2 Poles **.4-3** Amps **125, 250** VAC **28** VDC

Typical Applications

- Instrumentation
- Test Equipment
- Telecommunications
- Networking
- Handheld Appliances

Tech Specs

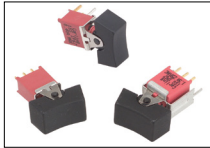

ISS-Series
Sealed
Sub-Miniature
Rocker Switch

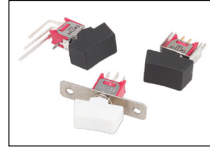

ISI-Series
Sub-Miniature
Rocker Switch



ISM-Series
Sealed Surface Mount
Sub-Miniature
Rocker Switch

Electrical

Contact Rating	refer to ordering scheme
Electrical Life	ISI-Series: 30,000 make & break cycles @ full load ISS & ISM-Series: 50,000 make & break cycles @ full load
Contact Resistance	20 mΩ max. initial @ 2-4 VDC 100mA for both silver & gold plated contacts
Insulation Resistance	1000 MΩ min.
Dielectric Strength	1500 Volts RMS @ sea level

Physical

Operating Temperature	-30°C to +85°C
Index of Protection	1SS & 1SM-Series: IP67
Solder Heat Resistance	MIL-STD-202, Method 210
Actuator Travel	25°

Material

Case	all UL94 V-0 ISI-Series: Diallyl phthalate (DAP) ISS-Series: Glass filled nylon 6/6, flame retardant, heat stabilized ISM-Series: Glass filled nylon 4/6, flame retardant, heat stabilized
Rocker	ISI-Series: Nylon (UL 94V-0) ISS & ISM-Series: Nylon, black standard, internal o-ring sealed
Bushing	ISI-Series: Brass, nickel plated ISS-Series: Glass filled nylon 6/6, flame retardant, heat stabilized (UL 94V-0) ISM-Series: Glass filled nylon 4/6, flame retardant, heat stabilized (UL 94V-0)
Housing	ISI-Series: Stainless Steel
Switch Support	ISI & ISM-Series: Brass, tin plated
Terminal Seal	Epoxy

Ordering Scheme

Sample Part Number **ISS - WMSP 1 - R2 / 2 M2 G E**

Selection 1 2 3 4 5 6 7 8

1. SERIES

ISS Sealed Sub-Miniature Rocker Switch

2. POLES

WMSP Single pole - uses terminals 1, 2 & 3
WMDP Double pole - uses terminals 1, 2, 3, 4, 5 & 6

3. CIRCUIT

() - momentary
Position: **1** **2** **3**

1	2-3, 5-6	Connected Terminals	2-1, 5-4
2	ON	NONE	ON
3	ON	NONE	(ON)
4	(ON)	OFF	ON
5	ON	OFF	(ON)

4. ACTUATOR STYLE

R1 Small Rocker
R2 Narrow Black Rocker

5. ACTUATOR COLOR

1 White
2 Black
3 Red
Other colors available, consult factory.

6. TERMINATION

M1 Solder Lug	M61 Snap-In, U bracket, 90° horizontal
M2 PCB	M71 Snap-In, U bracket, 90° horizontal
M6 PC Mount, 90° horizontal	VS21 Snap-In, U bracket
M7 PC Mount, 90° vertical	
VS2 PC Mount, U bracket	

See dimensional specifications.

7. CONTACTS / TERMINALS

Contact Material	Terminal Plating	Rating	Approvals
G silver ¹	gold over silver	3A 125VAC or 28VDC, 1.5A 250VAC	IP67
K gold ^{2,5}	tin ⁴	0.4VA max 20V max (AC/DC)	IP67
P silver ^{1,6}	tin ⁴	3A 125VAC or 28VDC, 1.5A 250VAC	IP67
R gold ²	gold ^{2,3}	0.4VA max 20V max (AC/DC)	IP67

8. EPOXY SEAL

E Epoxy Seal **0** without Epoxy Seal

Notes: Tin option not available with M1 terminal.
1 Movable contact and terminal platings: silver over copper alloy
2 Movable contact platings: gold over nickel over copper alloy
3 Terminal platings: gold over nickel over copper alloy
4 Terminal platings: tin over copper alloy
5 Terminal contact platings: gold over nickel alloy
6 Terminal contact platings: silver over nickel alloy

[Configure Complete Part Number >](#)

[Browse Standard Parts >](#)

Ordering Scheme

Sample Part Number 1S1 - MSP 1 - R2 / 2 M6 Q E

Selection 1 2 3 4 5 6 7 8

1. SERIES

1S1 Sub-Miniature Rocker Switch

2. POLES

MSP Single pole - uses terminals 1, 2 & 3
MDP Double pole - uses terminals 1, 2, 3, 4, 5 & 6

3. CIRCUIT

() - momentary
Position:

1	2	3
2-3, 5-6	Connected Terminals	2-1, 5-4
ON	NONE	ON
ON	NONE	(ON)
ON	OFF	ON
(ON)	OFF	(ON)
ON	OFF	(ON)

4. ACTUATOR STYLE

R1 Small Rocker
R2 Narrow Black Rocker
R3 Medium Rocker

5. ACTUATOR COLOR

1 White
2 Black
3 Red
 Other colors available, consult factory.

6. TERMINATION

M1 Solder Lug	M61 Snap-In, U bracket, 90° horizontal
M2 PCB	M71 Snap-In, U bracket, 90° horizontal
M6 PC Mount, 90° horizontal	VS21 Snap-In, U bracket
M7 PC Mount, 90° vertical	
VS2 PC Mount, U bracket	
VS3 PC Mount, U bracket	

See dimensional specifications.

7. CONTACTS / TERMINALS

Contact Material	Terminal Plating	Rating	Approvals
G silver ¹	gold over silver 1.5A 250VAC	3A 125VAC or 28VDC,	UL, CE
K gold ²	tin ³	0.4VA max 20V max (AC/DC) N/A	
P silver ¹	tin ³ 1.5A 250VAC	3A 125VAC or 28VDC,	UL, CE
Q silver ¹	silver ¹ 1.5A 250VAC	3A 125VAC or 28VDC,	UL, CE
R gold ²	gold ²	0.4VA max 20V max (AC/DC) N/A	

8. EPOXY SEAL

E Epoxy Seal **0** without Epoxy Seal

Notes:

- Tin option available with M1 termination.
- 1 Movable contact and terminal platings: silver over copper alloy
- 2 Movable contact and terminal platings: gold over nickel over copper alloy
- 3 Terminal platings: tin over nickel over copper alloy

[Configure Complete Part Number >](#)

[Browse Standard Parts >](#)

Ordering Scheme

Sample Part Number ISM - WMSP 1 - R2 - M2 G E

Selection 1 2 3 4 5 6 7

1. SERIES

ISM Sealed Surface Mount Sub-Miniature Rocker Switch

2. POLES

WMSP Single pole - uses terminals 1, 2 & 3

3. CIRCUIT

() - momentary
Position:

1	2	3
2-3	Connected Terminals	2-1
ON	NONE	ON
ON	NONE	(ON)
ON	OFF	ON
(ON)	OFF	(ON)
ON	OFF	(ON)

4. ACTUATOR STYLE

R2 Narrow Black Rocker

5. TERMINATION

M6 Surface Mount, 90° flat - horizontal / side
S6 Surface Mount, 90° horizontal / back
S7 Surface Mount, 90° vertical
 See dimensional specifications.

6. CONTACTS / TERMINALS

Contact Material	Terminal Plating	Rating	Approvals
G silver ¹	gold over silver	3A 125VAC or 28VDC,	IP67 1.5A 250VAC
K gold ^{2,5}	tin ⁴	0.4VA max 20V max (AC/DC)	IP67
P silver ^{1,6}	tin ⁴	3A 125VAC or 28VDC,	IP67 1.5A 250VAC
Q silver ¹	silver ¹	3A 125VAC or 28VDC,	IP67 1.5A 250VAC
R gold ²	gold ³	0.4VA max 20V max (AC/DC)	IP67

7. EPOXY SEAL

E Epoxy Seal **0** without Epoxy Seal

8. PACKAGING

T/R tape reel - 500 pieces per reel
 Switches are bulk packed, unless T/R is specified at the end of the part number.

Notes:

- Tin option not available with M1 termination.
- 1 Movable contact and terminal platings: silver over copper alloy
- 2 Movable contact platings: gold over nickel over copper alloy
- 3 Terminal platings: gold over nickel over copper alloy
- 4 Terminal platings: tin over copper alloy
- 5 Terminal contact platings: gold over nickel alloy
- 6 Terminal contact platings: silver over nickel alloy

[Configure Complete Part Number >](#)

[Browse Standard Parts >](#)

Dimensional Specs

inches [millimeters]

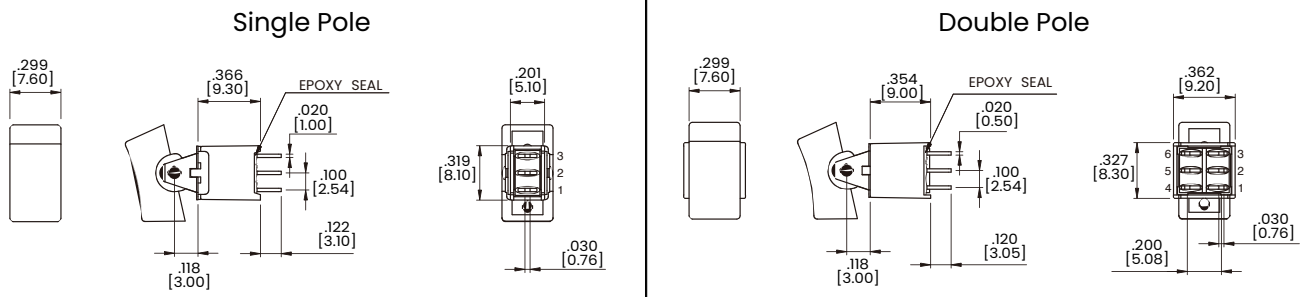

Actuator Options

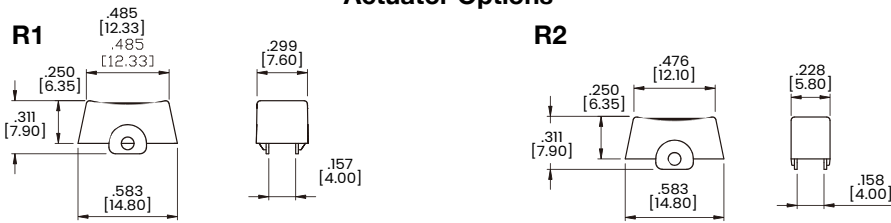

Termination Options

M1 STD. Solder Lug

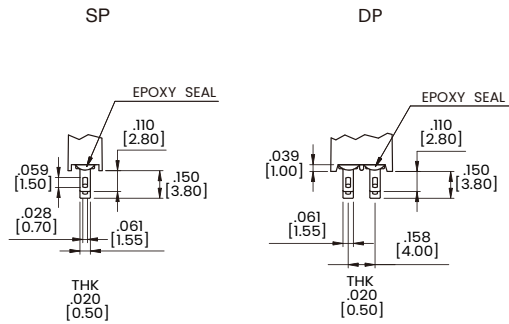

M2 PC Thru-Hole

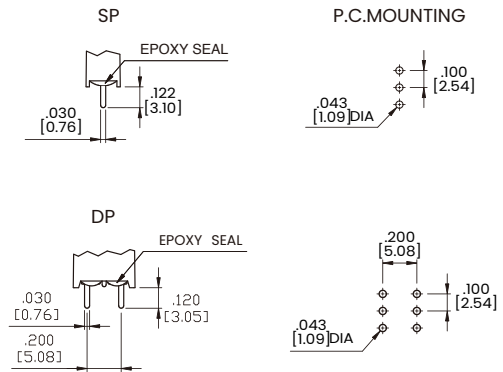

M6 Single Pole

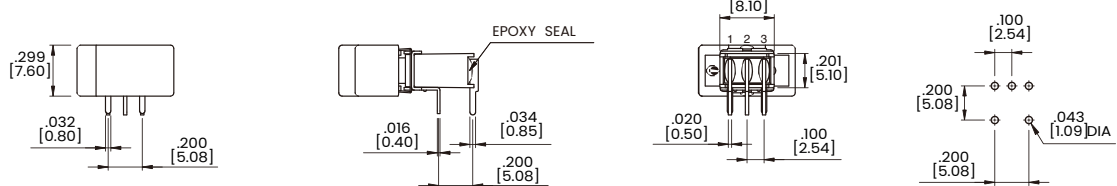

M6 Double Pole

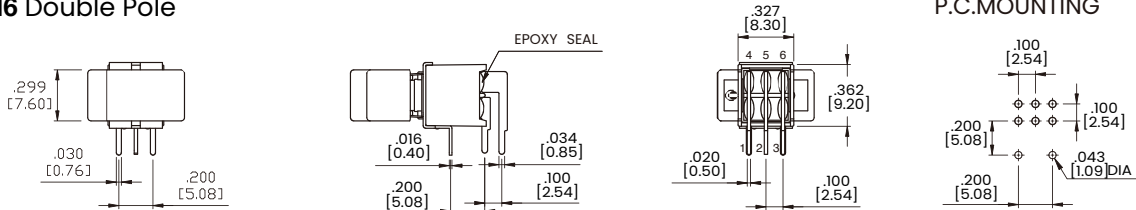

Dimensional Specs

inches [millimeters]

Termination Options

M7 Single Pole

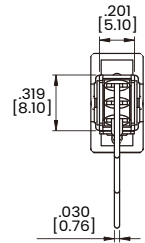
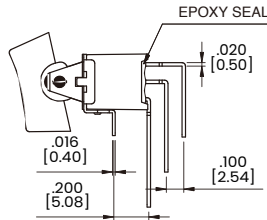
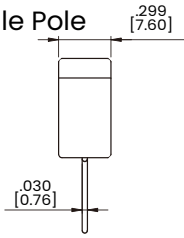

P.C.MOUNTING

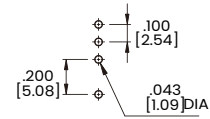

M7 Double Pole

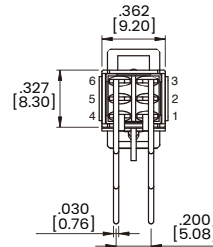
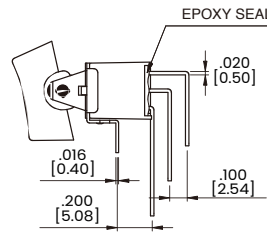
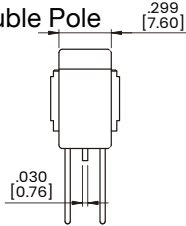

P.C.MOUNTING

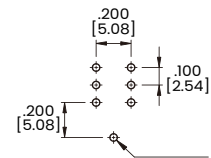

VS2 Single Pole

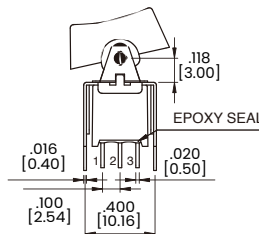
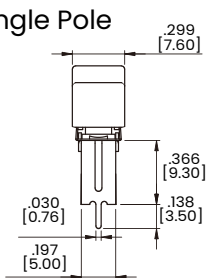

P.C.MOUNTING

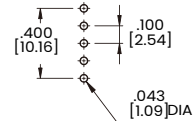

VS2 Double Pole

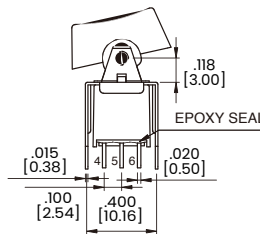
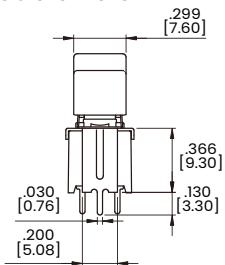

P.C.MOUNTING

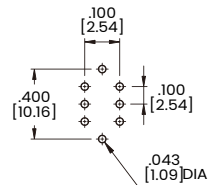

Snap-In Termination Options

M61

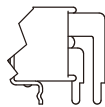
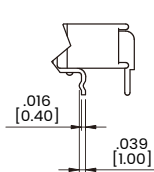

M71

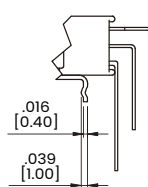

VS21

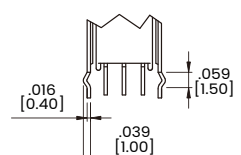
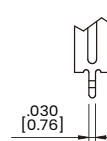

* PC Mounting for M61, M71, VS21 refer to M6, M7, VS2 respectively.

Dimensional Specs

inches [millimeters]

Single Pole

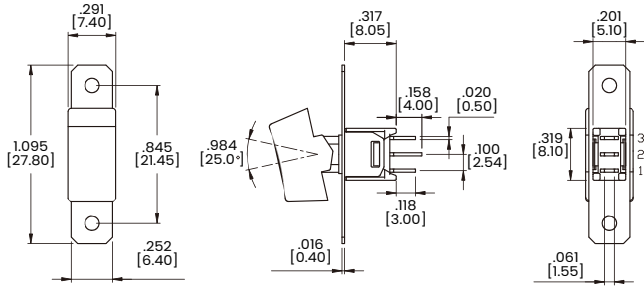

Double Pole

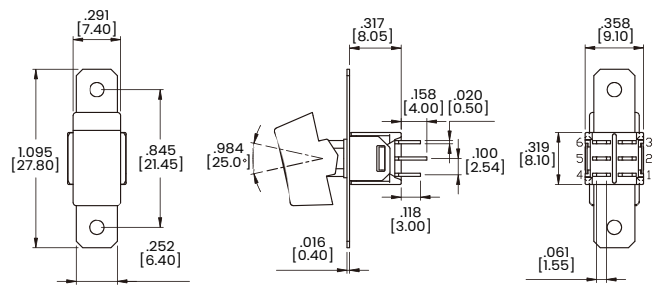

Actuator Options

R1

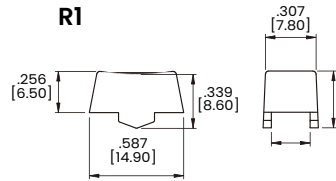

R2

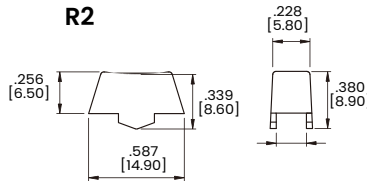

R3

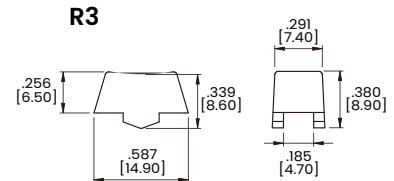

Termination Options

M1 STD. Solder Lug

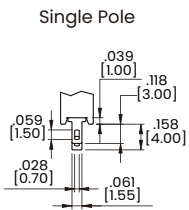

Double Pole

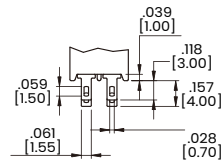

M2 PC Thru-Hole

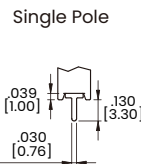

Double Pole

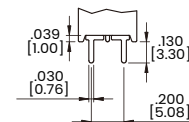

M6 Single Pole

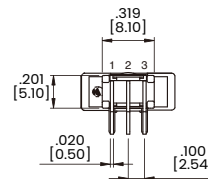
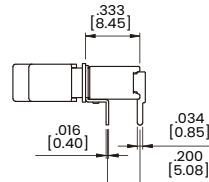
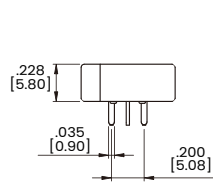

P.C.MOUNTING

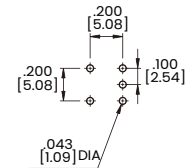

M6 Double Pole

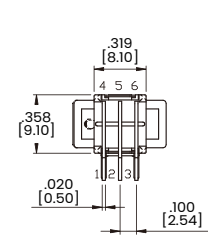
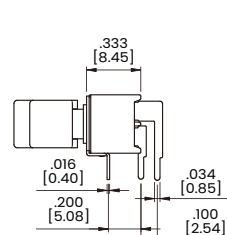
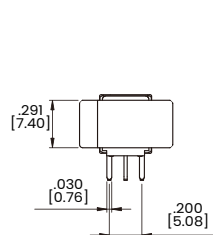

P.C.MOUNTING

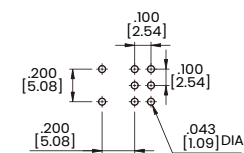

Dimensional Specs

inches [millimeters]

Termination Options

M7 Single Pole

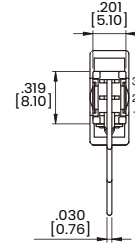
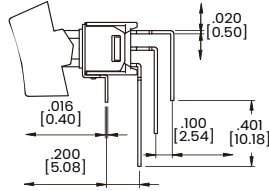
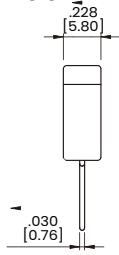

P.C. MOUNTING

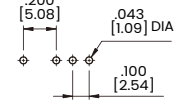

M7 Double Pole

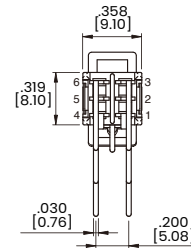
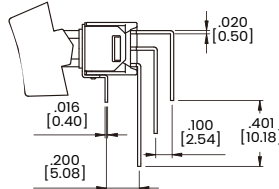
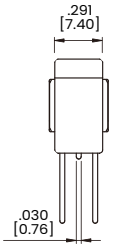

P.C. MOUNTING

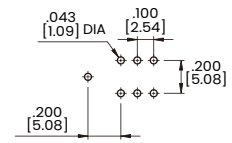

VS2-VS3 Single Pole

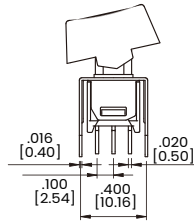
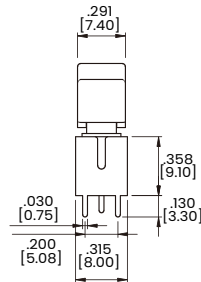
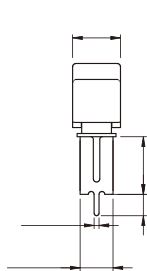

P.C. MOUNTING

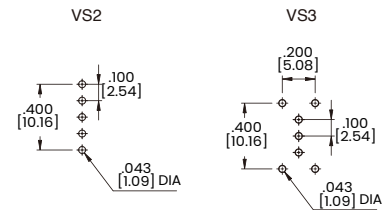

VS2-VS3 Double Pole

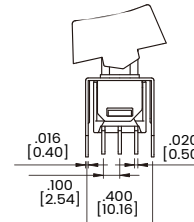
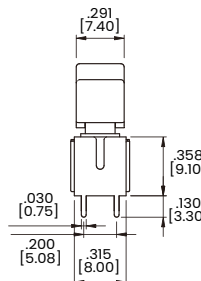
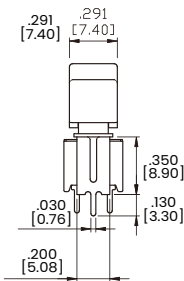

P.C. MOUNTING

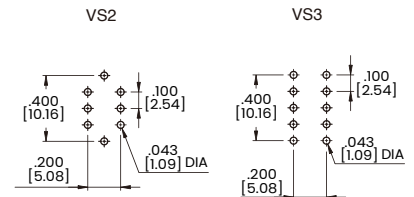

Snap-In Termination Options

M61

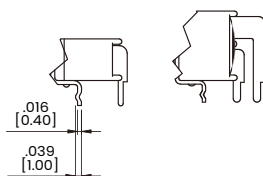

M71

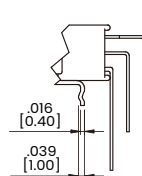

VS21

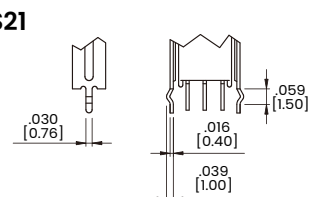

* PC Mounting for M61, M71, VS21 refer to M6, M7, VS2 respectively.

Dimensional Specs

inches [millimeters]

M6 Single Pole

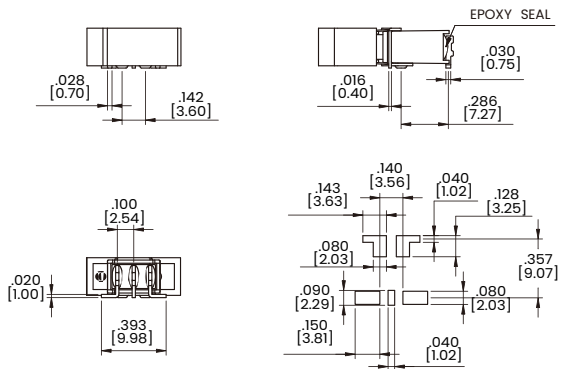

S6 Single Pole

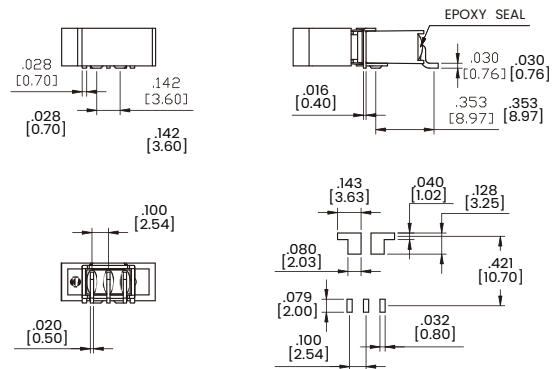

S7 Single Pole

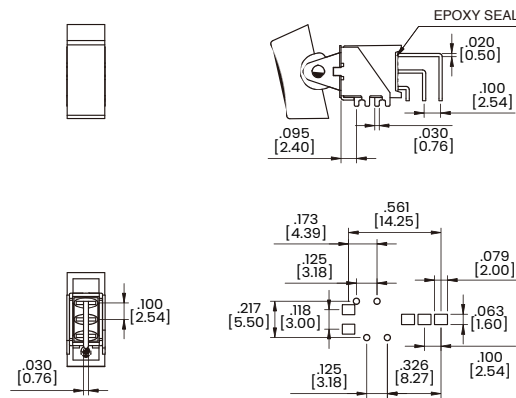

Termination Options

M6

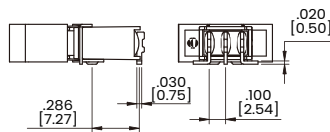

S6

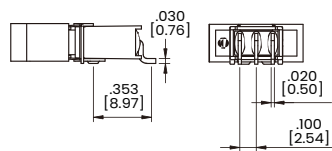

S7

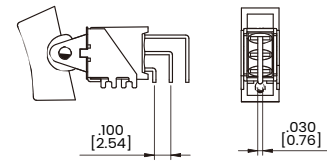

Authorized Sales Representatives and Distributors

Click on a region of the map below to find your local representatives and distributors or visit www.carlingtech.com/findarep.



About Carling

Founded in 1920, Carling Technologies is a leading manufacturer of electrical and electronic switches and assemblies, circuit breakers, electronic controls, power distribution units, and multiplexed power distribution systems. With six ISO9001 and IATF16949 registered manufacturing facilities and technical sales offices worldwide, Carling Technologies Sales, Service and Engineering teams do much more than manufacture electrical components, they engineer powerful solutions! To learn more about Carling please visit www.carlingtech.com/company-profile.

To view all of Carling's environmental, quality, health & safety certifications please visit www.carlingtech.com/environmental-certifications.

© Carling Technologies, Inc.

9. Carling is a registered trademark of Carling Technologies, Inc. in the U.S. and other countries.

X-ON Electronics

Largest Supplier of Electrical and Electronic Components

Click to view similar products for [Rocker Switches](#) category:

Click to view products by [Carling](#) manufacturer:

Other Similar products are found below :

[LTILA6E-1S-WH-RC-FN12VXCR1](#) [6-1571986-9](#) [8007K26N324V52](#) [8055K23Z7V](#) [8055K32Z7V](#) [8055K52Z7V](#) [8138K20E6M50](#) [84206L](#)
[84312LX](#) [PREDD5-07F-BB0GW](#) [999-16716-002](#) [999-16716-003](#) [999-16716-004](#) [A101J1V3Q004](#) [A101J2ZQ004](#) [A101J4ZQ004](#)
[A101J51CB0004](#) [A103J1ZQ004](#) [A201J1AQ004](#) [A201J3ZB004](#) [A201J50ZQ004](#) [A203J51ZQ0004](#) [A435S1YZQ](#) [H8500XBBBBL-A](#)
[H8653VBBG2577W](#) [HB130CHNWWNAAC](#) [R13112ABB-602W](#) [1251.0303](#) [AE205J60V3B004](#) [1352.0107](#) [1571099-3](#) [1571987-4](#)
[1571987-5](#) [1571989-7](#) [1571988-5](#) [B123J77V7B2](#) [B226J50W4Q22P](#) [B433J37ZQ22M](#) [160212E](#) [1634200-7](#) [1801.1164](#) [1839.1502](#) [PANEL-](#)
[PLUG-VHP-BLACK](#) [PANEL-PLUG-VHP-WT](#) [K1ABBSCADN](#) [KG312A2DXD246X](#) [250011E714](#) [2600HM11E](#) [2600R21E](#) [260413E](#)