

LS-Series

ROCKER SWITCHES

The LS-Series Softspot illuminated rocker switches feature a three-color high brightness light sequence, from a single lamp. These switches are designed with a standard nylon snap-in bracket and “Drip-Dry” construction that protects the front panel from dust and moisture.

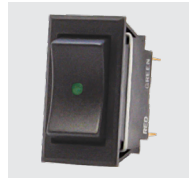

Product Highlights:

- Water Resistant Construction
- Independent or Dependent Illumination•
- Up to 3 Different Colors Under a Single Lens
- Multiple Termination Options

Typical Applications:

- Marine
- Transportation



Dielectric Strength

1000V - live to dead metal parts

Electrical Life

50,000 cycles - maintained
25,000 cycles - momentary

Operating Temperature

0°F to 150°F (-17.8°C to +65.6°C)

LS1511 - 13 - BL - BL - 012

1
Base Part Number

2
Lighting Sequence

3
Actuator Color

4
Base Color

5
Lamp Voltage

1 BASE PART NUMBER: SERIES / POLES / ILLUMINATION / CIRCUITRY / RATING / TERMINATION³

10A 250VAC, 15A 125VAC, 3/4 HP 125-250VAC, 15A 15-28VDC

Single Pole	Solder Lug	.250 Tab QC	Screw Terms	Wire Leads
On-None-Off	LS1510	LS1511	LS1514	LS1515
On-None-(Off)	LS1520	LS1521	LS1524	LS1525
(On)-None-Off	LS1530	LS1531	LS1534	LS1535
On-None-On	LS1540	LS1541	LS1544	LS1545
On-None-(On)	LS1550	LS1551	LS1554	LS1555
On-Off-On	LS1560	LS1561	LS1564	LS1565
On--Off-(On)	LS1570	LS1571	LS1574	LS1575
(On)-Off-(On)	LS1580	LS1581	LS1584	LS1585

2 LIGHTING SEQUENCE^{1,2}

	position 1	position 2	position 3
01	red	red	red
02	amber	amber	amber
03	green	green	green
10	red	---	none
11	red	clear	red
12	red	clear	amber
13	red	clear	green
14	red	clear	blue
15	red	clear	clear
20	amber	---	none
21	amber	clear	red
22	amber	clear	amber
23	amber	clear	green
24	amber	clear	blue
25	amber	clear	clear
30	green	---	none
31	green	clear	red
32	green	clear	amber
33	green	clear	green
34	green	clear	blue
35	green	clear	clear
40	blue	---	none
41	blue	clear	red
42	blue	clear	amber
43	blue	clear	green
44	blue	clear	blue
45	blue	clear	clear
50	clear	---	none
51	clear	clear	red
52	clear	clear	amber
53	clear	clear	green
54	clear	clear	blue
55	clear	clear	clear

3 ACTUATOR COLOR⁴

BL Black
WH White

4 BASE COLOR⁴

BL Black
WH White

5 LAMP VOLTAGE²

incandescent
6V 6 volt
12V 12 volt
18V 18 volt
24V 24 volt
28V 28 volt

neon
125N 125 volt neon
250N 250 volt neon

Notes:

- Independent lamp is standard. Dependent lamp with ON-OFF function (including momentary) is available with Lighting Sequences 10, 20, 30, 40 and 50. (No light in OFF position.)
- Green and blue not recommended with 125 volt or 250 volt neon lamps.
- Additional terminations available. Consult factory.
- Custom colors available. Consult factory.
- () Indicates momentary function.

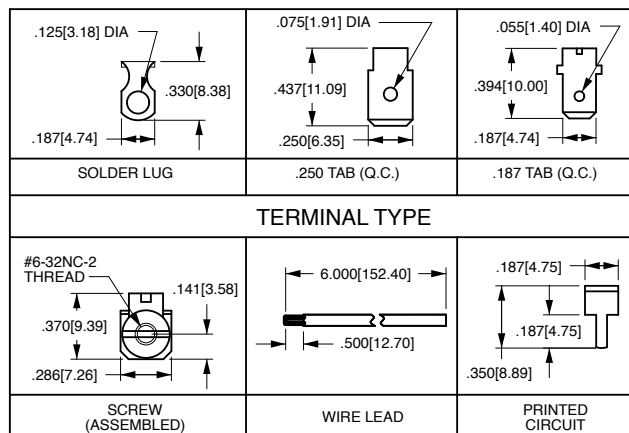
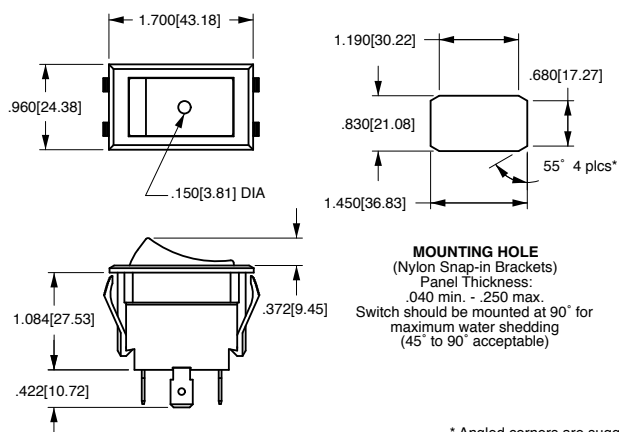

* Angled corners are suggested for optimum fit. Standard rectangular cutout is acceptable.

*Manufacturer reserves the right to change product specification without prior notice.

Authorized Sales Representatives and Distributors

Click on a region of the map below to find your local representatives and distributors or visit www.carlingtech.com/findarep.



About Carling

Founded in 1920, Carling Technologies is a leading manufacturer of electrical and electronic switches and assemblies, circuit breakers, electronic controls, power distribution units, and multiplexed power distribution systems. With four ISO9001 and IATF16949 registered manufacturing facilities and technical sales offices worldwide, Carling Technologies Sales, Service and Engineering teams do much more than manufacture electrical components, they engineer powerful solutions! To learn more about Carling please visit www.carlingtech.com/company-profile.

To view all of Carling's environmental, quality, health & safety certifications please visit www.carlingtech.com/environmental-certifications

Worldwide Headquarters

Carling Technologies, Inc.
60 Johnson Avenue, Plainville, CT 06062
Phone: 860.793.9281 **Fax:** 860.793.9231
Email: sales@carlingtech.com

Northern Region Sales Office: nrsm@carlingtech.com
Southeast Region Sales Office: sersm@carlingtech.com
Midwest Region Sales Office: mrrsm@carlingtech.com
West Region Sales Office: wrsm@carlingtech.com
Latin America Sales Office: larsm@carlingtech.com

Asia-Pacific Headquarters

Carling Technologies, Asia-Pacific Ltd.,
Suite 1607, 16/F Tower 2, The Gateway,
Harbour City, 25 Canton Road,
Tsimshatsui, Kowloon, Hong Kong
Phone: Int + 852-2737-2277 **Fax:** Int + 852-2736-9332
Email: sales@carlingtech.com.hk

Shenzhen, China: shenzhen@carlingtech.com
Shanghai, China: shanghai@carlingtech.com
Pune, India: india@carlingtech.com
Kaohsiung, Taiwan: taiwan@carlingtech.com
Yokohama, Japan: japan@carlingtech.com

Europe | Middle East | Africa Headquarters

Carling Technologies LTD
4 Airport Business Park, Exeter Airport,
Clyst Honiton, Exeter, Devon, EX5 2UL, UK
Phone: Int + 44 1392.364422 **Fax:** Int + 44 1392.364477
Email: ltd.sales@carlingtech.com

Germany: gmbh@carlingtech.com
France: sas@carlingtech.com



Carling Technologies®

Innovative Designs. Powerful Solutions.

X-ON Electronics

Largest Supplier of Electrical and Electronic Components

Click to view similar products for [Rocker Switches](#) category:

Click to view products by [Carling](#) manufacturer:

Other Similar products are found below :

[VKD2GHNB-00000-000](#) [VSD2GNNB-00000-000](#) [6-1571986-5](#) [6-1571986-9](#) [8055K52Z7V](#) [8138K20E6M50](#) [FMC18A2200002](#) [84206L](#)
[84312LX](#) [PREDD4-07F-BB0FW](#) [PREDD5-07F-BB0GW](#) [PRFDD1-16F-BB000](#) [PRFDD3-16F-BB000](#) [1-1634201-0](#) [999-16702-001](#)
[A101J2ZQ004](#) [A101J4ZQ004](#) [A101J51CB0004](#) [A107J51ZQ0004](#) [A201J1AQ004](#) [A201J1AV2Q004](#) [A201J3ZB004](#) [A201J50ZQ004](#)
[A203J51ZQ0004](#) [A226L11YZQ](#) [A22L11A](#) [A435S1YZQ](#) [H8500XBBBBL-A](#) [H8653VBBG2577W](#) [HB130CHNWWNAAC](#) [1251.0303](#)
[AE205J60V3B004](#) [RH110C2NBB](#) [1352.0107](#) [1363.0201](#) [AML25GBF2AA03GR](#) [1571099-3](#) [1571987-4](#) [1571987-5](#) [1571989-7](#)
[B123J77V7B2](#) [B226J50W4Q22P](#) [B433J37ZQ22M](#) [160212E](#) [1801.1164](#) [1831.1102](#) [1833.3402](#) [1837.1118](#) [1838.8302](#) [1839.1502](#)