

PD-Series

Ground Fault Circuit Protection

SmartGuard is an equipment ground fault protection device that functions as a standard high-quality Carling hydraulic/magnetic circuit breaker, offering customized overload and short circuit protection. In addition, this breaker senses and guards against faults to ground using a state of the art integrated circuit developed by Carling. This new technology detects faults and when a fault occurs, the breaker trips and an LED illuminates. The LED gives a clear indication that the trip occurred as a result of leakage. This protection helps prevent serious equipment damage and fire.

Features:

- ♦ Overload, short circuit and ground fault protection in a single package
- ♦ Handle style actuators with optional "handguard"
- ♦ Wiping Contacts - Mechanical linkage with two-step actuation – cleans contacts, provides high, positive contact pressure & longer contact life
- ♦ A trip-free mechanism, a safety feature, makes it impossible to manually hold the contacts closed during overload or fault conditions.
- ♦ A common trip linkage between all poles, another safety feature, ensures that an overload in one pole will trip all adjacent poles.
- ♦ Front panel or DIN rail mounting options
- ♦ "State of the art" integrated circuit developed by Carling
- ♦ Equipment leakage sensitivity from 10 to 100 milliamps
- ♦ Integral push-to-test button and LED "tripped" indicator
- ♦ Immediate reset after fault has been cleared



Agency Certifications:

- | | |
|------------------|--|
| UL Standard 1077 | Component Recognition Program as Equipment Leakage Circuit Interrupter and, Protectors, Supplementary (FTTJ2, File E177510). |
| UL Standard 943 | Tested as Ground Fault Circuit Interrupters for Equipment Protection. |
| CSA Certified | Component Equipment Leakage Current Interrupter with Supplementary Protector, under Class C22.2, No. 144-M91, File LR47848-50 |
| TUV Certified | IEC 947-2 and appendix B: Circuit Breakers incorporating Residual Current Protection. Complies with waveform requirements of IEC 1008-1, Type A. |



Carling Technologies™

Innovative Designs. Powerful Solutions.

Innovative Designs. Powerful Solutions.

Carling Technologies, Inc.
60 Johnson Avenue • Plainville, CT 06062-1177
Phone: (860) 793-9281 • Fax: (860) 793-9231
Email: sales@carlingtech.com • www.carlingtech.com

Electrical Tables

Table A: Lists UL Recognized & CSA Certified configurations and performance capabilities as a Component Supplementary Protector.

CIRCUIT CONFIGURATION	VOLTAGE			CURRENT RATING		INTERRUPTING CAPACITY (AMPS)	LEAKAGE CURRENT MUST - TRIP RATING (MILLIAMPS)
	MAX RATING VOLTS	FREQUENCY HERTZ	PHASE	FULL LOAD AMPS	GENERAL PURPOSE AMPS	UL / CSA	
						WITHOUT BACKUP FUSE	
SERIES	120/208	50/60	1	1-50	---	5000	7-100
	120/208	50/60	3	1-50	---	5000	7-100
	208-240	50/60	3	1-50	---	2000	7-100
	480Y	50/60	3	1-30	30,1-50	2000	7-100

Table B: Lists TUV Certified configurations and performance capabilities as a Circuit breaker incorporating residual current protection.

CIRCUIT CONFIGURATION	VOLTAGE			CURRENT RATING	LEAKAGE CURRENT MUST - TRIP RATING (MILLIAMPS)	INTERRUPTING CAPACITY (AMPS)		
	MAX RATING VOLTS	FREQUENCY HERTZ	PHASE	FULL LOAD AMPS		ULTIMATE S/C BREAKING CAPACITY (Icu)	SERVICE S/C BREAKING CAPACITY (Ics)	RESIDUAL S/C MAKE/BREAK CURRENT (Iam)
SERIES	120-240	50/60	1	1-50	7-100mA	5000	3750	1250
	200-240	50/60	3	1-50	7-100mA	2667	2000	1000
	380-415	50/60	3-Y	1-50	7-100mA	2000	2000	1000
	380-415	50/60	1	1-50	7-100mA	2000	2000	1000

Electrical

Maximum Voltage AC, 480 WYE/277 VAC, 50/60 Hz
 Standard Current Ratings 1.00, 2.50, 5.00, 7.50, 10.0, 15.0, 20.0, 25.0, 30.0, 35.0, 40.0 & 50.0 amps. For other ratings, consult factory.
 Insulation Resistance Minimum of 100 Megohms @ 500 VDC.
 Dielectric Strength 1960 VAC, 60 Hz for one minute between all electrically isolated terminals.
 Resistance, Impedance from Line to Load Terminal (Values Based on Series Trip Circuit Breaker)

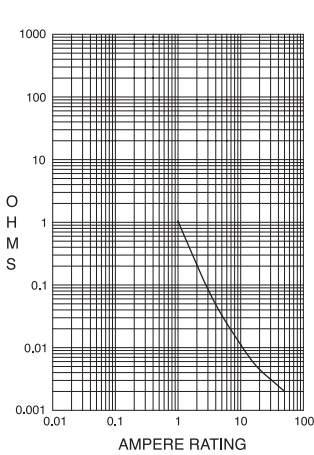

Ampere Rating

CURRENT (AMPS)	TOLERANCE (%)
0.10 - 5.0	15%
5.1 - 20.0	25%
20.1 - 50.0	35%

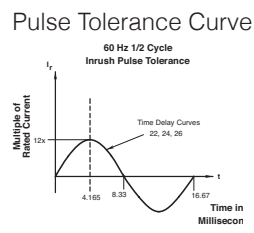

Leakage To Ground

Standard Must Trip
 Leakage Current Ratings 7, 10, 15, 30, 50 & 100 milliamps. For other ratings, consult factory.
 Trip Time 300 ms Max. @ 100%, 40ms Max. @ 500% of must trip leakage current.
 Test Button On breaker face above actuator.
 Leakage Trip Indicator Red LED on breaker face above actuator.

Mechanical

Endurance 10,000 ON-OFF operations @ 6 per minute; with rated current and voltage.
 Trip Free All SmartGuard equipment leakage circuit breakers will trip on overload or leakage to ground, even when actuator is forcibly held in the ON position.
 Trip Indication The actuator moves to the OFF position when an overload or earth leakage ground fault causes the breaker to trip. The LED is illuminated when leakage to ground causes the circuit breaker to trip.

Physical

Number of Poles 2, 3 & 4
 Length (included switched or unswitched neutral) 4.2 inches (106.7 mm)
 Width 2-pole: 3.0 inches (76.2 mm)
 3-pole: 3.75 inches (95.3 mm)
 4-pole: 4.5 inches (114.3 mm)
 Depth 2.5inches (63.5mm).
 Weight: 2-pole 16.0 oz. (453.6 gm)
 3-pole: 21.4 oz. (606.7 gm)
 4-pole: 26.9 oz. (762.6 gm)
 Standard Colors Housing - gray;
 Actuator - black, red, or white
 Mounting Front Panel or Standard 35mm Symmetrical DIN Rail (35 x 7.5 or 35 x 15mm per DIN EN5002).
 Termination Box Lug

Environmental

Operating Temperature +10°C to +50°C

*Manufacturer reserves the right to change product specification without prior notice.

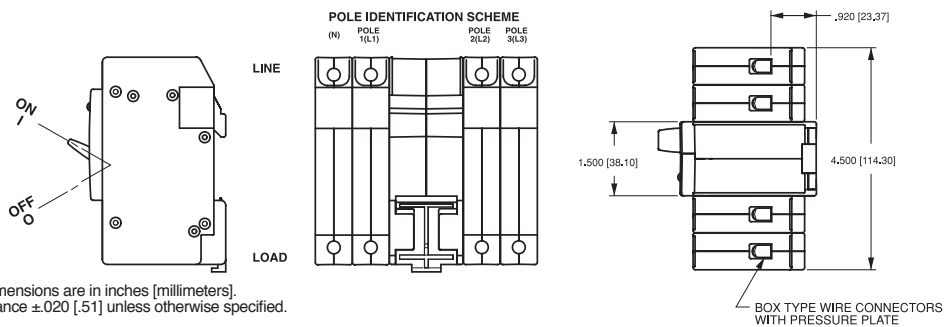
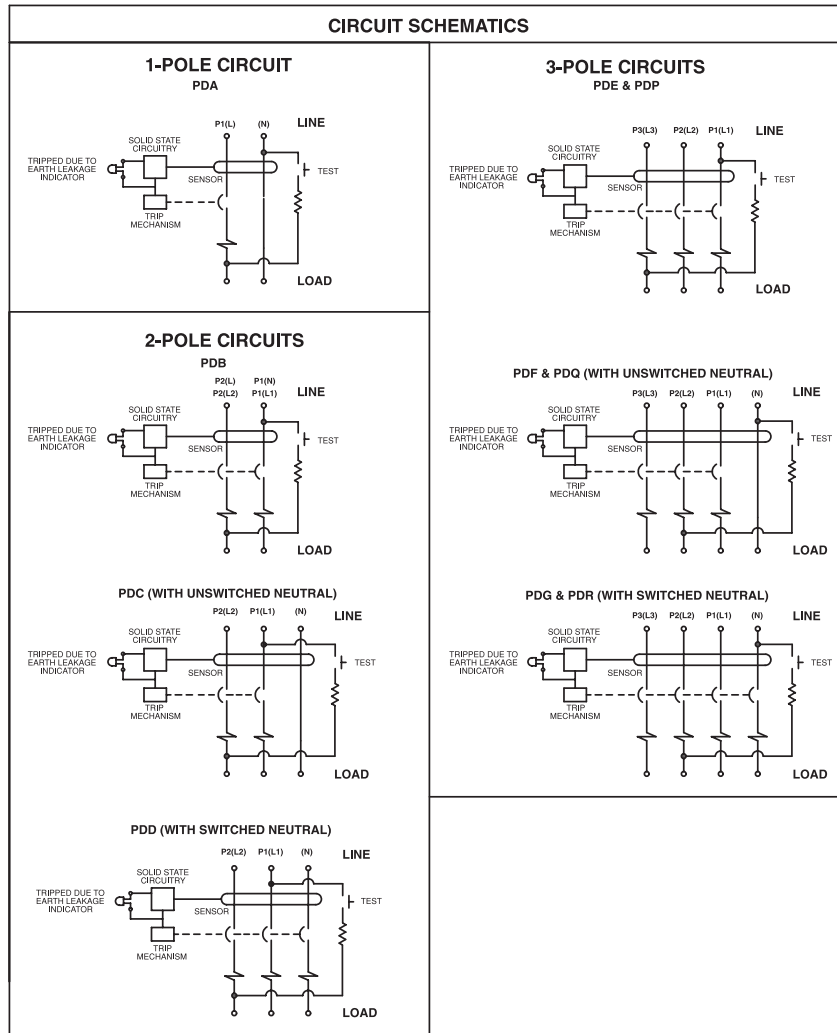

TIME DELAY VALUES										
PERCENT OF RATED CURRENT										
	DELAY	100%	125%	150%	200%	400%	600%	800%	1000%	1200%
TRIP TIME (SECONDS)	20	No Trip	May Trip	.040 MAX	.035 MAX	.030 MAX	.025 MAX	.020 MAX	.017 MAX	.015 MAX
	22	No Trip	.700 - 12.0	.350 - 4.00	.130 - 1.30	.027 - .220	.008 - .130	.004 - .090	.004 - .045	.004 - .040
	24	No Trip	10.0 - 160	6.00 - 60.0	2.20 - 20.0	.300 - 3.00	.050 - 1.30	.007 - .500	.005 - .060	.005 - .040
	26	No Trip	50.0 - 700	32.0 - 350	10.0 - 90.0	1.50 - 15.0	.500 - 7.00	.020 - 3.00	.006 - 2.00	.005 - 1.00

Notes:
 Other time delay values available, consult factory.
 Delay Curves 21,22,24,26: Breakers to hold 100% and must trip at 125% of rated current and greater within the time limit shown in this curve.
 Delay Curve 20: Breakers to hold 100% and must trip at 150% of rated current and greater within the time limit shown in this curve.
 All Curves: Curve data shown represents breaker response at ambient temperature of 77°F (25°C) with no preloading. Breakers are mounted in standard wall-mount position.
 The minimum inrush pulse tolerance handling capability is 12 times the rated current. These values are based on a 60 Hz 1/2 cycle, 8.33 ms pulse.

PDA & PDB

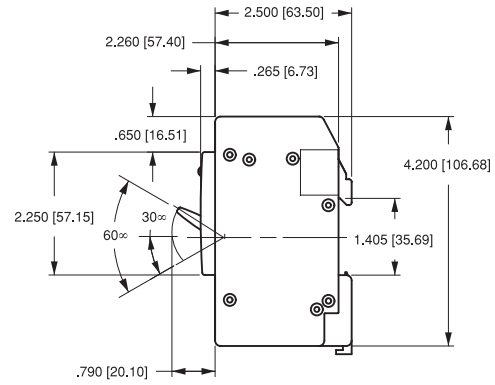
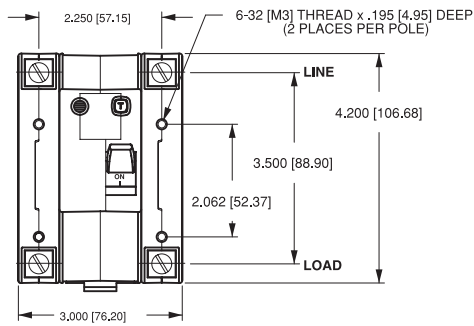

PDC & PDD

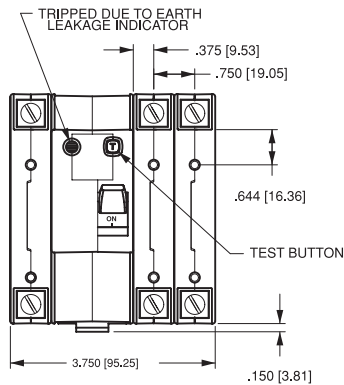

PDE & PDP

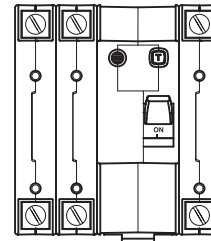

**PDF, PDG
PDQ & PDR**

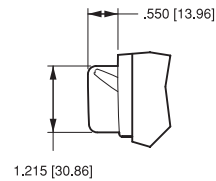
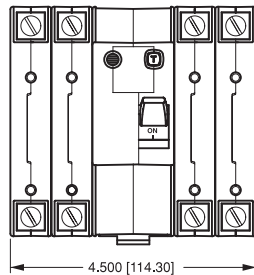

OPTIONAL HANDLE GUARD

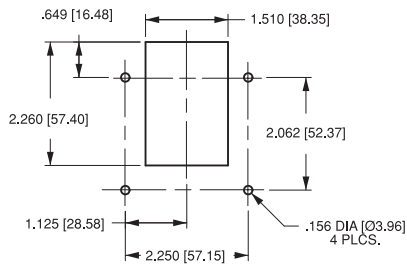

PANEL CUT-OUT DETAIL

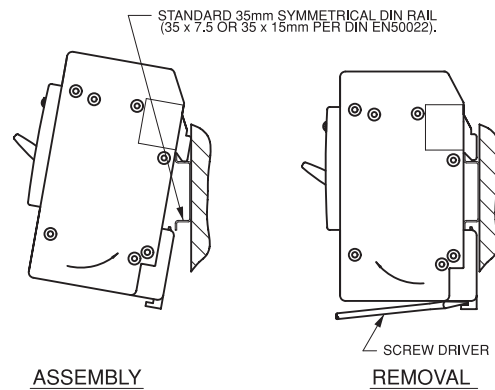

Notes:

- 1 All dimensions are in inches [millimeters].
- 2 Tolerance ± 0.020 [.51] unless otherwise specified.

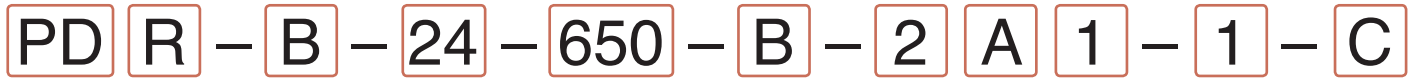

1 Series 2 System Voltage/Poles 3 Circuit 4 Frequency & Delay 5 Current Rating 6 Equipment Leakage - Trip Current 7 Terminal 8 Actuator 9 Actuator Color 10 Mounting 11 Agency Approval

1 SERIES
PD

2 SYSTEM VOLTAGE / POLES¹

System Voltage	Poles
A 120VAC 1Ø	One plus unswitched neutral
B 120/240 VAC 1Ø	Two
C 120/208 VAC 1Ø, 120/240 VAC 1Ø	Two plus unswitched neutral
D 120/208 VAC 1Ø, 120/240 VAC 1Ø	Two plus switched neutral
E 208/240 VAC 3Ø	Three
F 208/240 VAC 3Ø	Three plus unswitched neutral
G 208/240 VAC 3Ø	Three plus switched neutral
P 480Y VAC 3Ø	Three
Q 480Y VAC 3Ø	Three plus unswitched neutral
R 480Y VAC 3Ø	Three plus switched neutral

3 CIRCUIT
B Series Trip (Current)

4 FREQUENCY & DELAY

20 50/60Hz Instantaneous	24 50/60Hz Medium
22 50/60Hz Short	26 50/60Hz Long

5 CURRENT RATING (AMPERES)

CODE	AMPERES	CODE	AMPERES	CODE	AMPERES	CODE	AMPERES
410	1.000	445	4.500	610	10.000	618	18.000
512	1.250	450	5.000	710	10.500	620	20.000
415	1.500	455	5.500	611	11.000	622	22.000
517	1.750	460	6.000	711	11.500	624	24.000
420	2.000	465	6.500	612	12.000	625	25.000
522	2.250	470	7.000	712	12.500	630	30.000
425	2.500	475	7.500	613	13.000	635	35.000
527	2.750	480	8.000	614	14.000	640	40.000
430	3.000	485	8.500	615	15.000	650	50.000
435	3.500	490	9.000	616	16.000		
440	4.000	495	9.500	617	17.000		

6 EQUIPMENT LEAKAGE - TRIP CURRENT (MILLIAMPS)²

B 7	D 15	F 50
C 10	E 30	G 100

7 TERMINAL
2 Front Connected Box Lug

8 ACTUATOR
A Handle
B Handle w/ handguard

9 ACTUATOR COLOR & LEGEND⁴

Actuator Color	I-O	ON-OFF	Dual	Legend Color
White	A	B	1	Black
Black	C	D	2	White
Red	E	F	3	White

10 MOUNTING³
1 THREADED INSERT 6-32 X 0.195 INCHES
2 THREADED INSERT ISO M3 X 6.5 MM

11 AGENCY APPROVAL
C UL Recognized & CSA Certified
U TUV Certified

Notes:

- Units with a switched or unswitched neutral connection are the same size as a unit with an additional breaker pole (e.g. a 2-pole unit with a switched or unswitched neutral is the same physical size as a 3-pole unit.)
- Switched neutral poles contain the same overcurrent protection as the other poles. The leakage currents shown will cause the breaker to trip (must-trip current). The must-hold current is 67% of the must-trip current.
- All breakers are front panel mountable using screw size shown. Breakers may also be mounted on either 35mm x 7.5mm or 35mm x 15mm symmetrical DIN rail.
- TUV certified units must have I-O or Dual legends

Time Delay Curves
Instantaneous

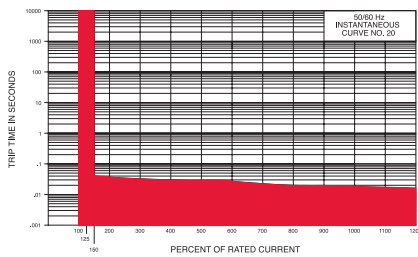

Medium

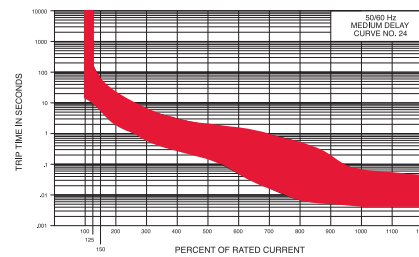

Short

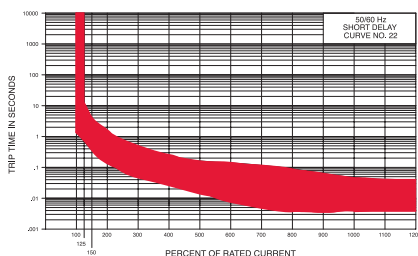

Long

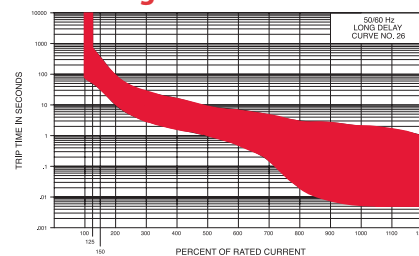

REV_GFCI_PD_0312

X-ON Electronics

Largest Supplier of Electrical and Electronic Components

Click to view similar products for [Circuit Breakers](#) category:

Click to view products by [Carling](#) manufacturer:

Other Similar products are found below :

[LUGZX66-1-61-20.0-44](#) [M39019/04-249S](#) [M39019/04-313S](#) [M55629/1-001](#) [M55629/1-016](#) [M55629/1-018](#) [M55629/1-021](#) [M55629/1-033](#)
[M55629/1-036](#) [M55629/1-046](#) [M55629/1-048](#) [M55629/1-058](#) [M55629/1-060](#) [M55629/1-067](#) [M55629/1-070](#) [M55629/1-079](#) [M55629/1-084](#)
[M55629/1-085](#) [M55629/1-101](#) [M55629/1-108](#) [M55629/1-109](#) [M55629/11-102](#) [M55629/1-120](#) [M55629/12-045](#) [M55629/12-046](#) [M55629/1-](#)
[243](#) [M55629/1-330](#) [M55629/1-331](#) [M55629/1-351](#) [M55629/1-366](#) [M55629/1-387](#) [M55629/1-388](#) [M55629/1-401](#) [M55629/1-430](#) [M55629/1-](#)
[450](#) [M55629/1-453](#) [M55629/2-022](#) [M55629/2-037](#) [M55629/2-082](#) [M55629/2-099](#) [M55629/2-101](#) [M55629/2-102](#) [M55629/2-115](#) [M55629/2-](#)
[116](#) [M55629/2-183](#) [M55629/21-HM-HM](#) [M55629/21-NS-NS](#) [M55629/21-SK-UK](#) [M55629/22-NR-NR-NR](#) [M55629/22-RS-RS-RS](#)