

# L-Series

Sealed Rocker Switches

[PRODUCT WEBPAGE](#)

*request sample, configure part, watch video*



The L-Series snap-in rocker switches offer countless unique options including choices for ratings, colors, illuminations and laser etched legends. These single or double pole switches feature a broad choice of actuator styles, colors, and lenses.

**1-2**  
Poles

**.4-20**  
Amps

**125-250**  
VAC

**12-24**  
VDC

## Typical Applications

- Construction
- Agriculture
- On-Highway

# Design Features

## LED LIGHTING

Utilize less current and are not affected by vibration, providing long lasting illumination. Available in 3 standard colors.

## SEAL PROTECTION

Locks out elements such as water, dust & debris. Sealed to IP67 for Above-Panel Components

## TERMINALS

Available with 2 industry standard termination options: .250 or .187 tabs with up to 12 terminal options.

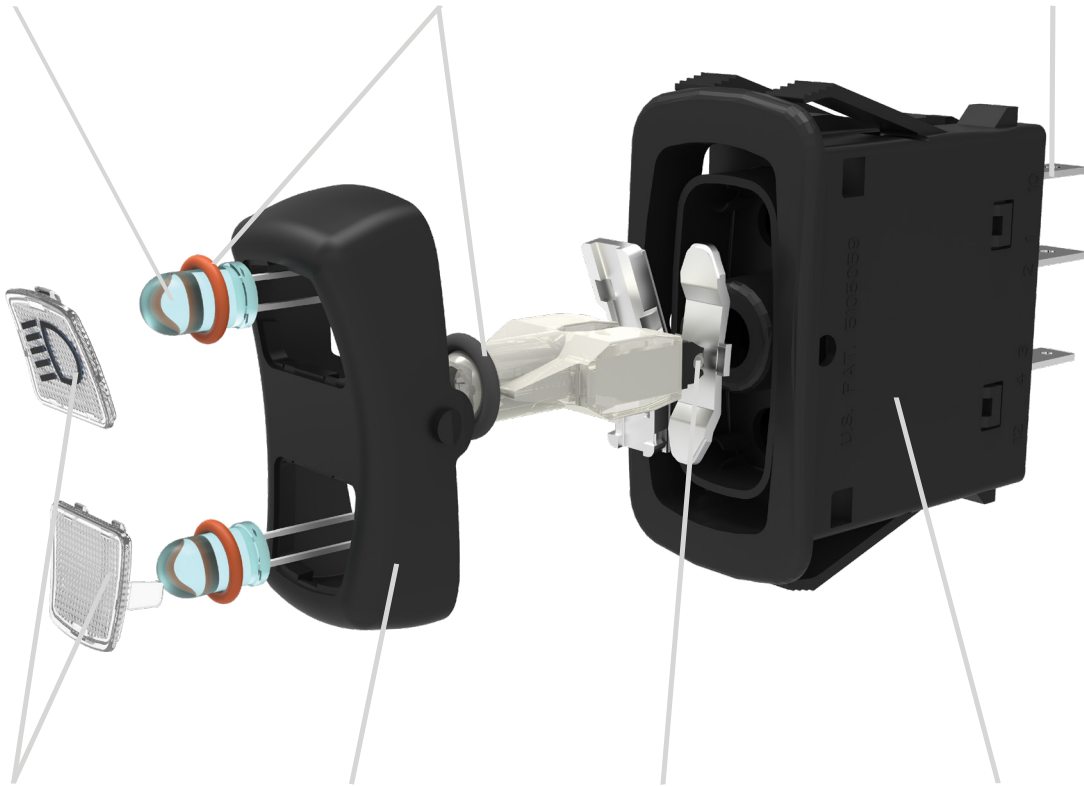

## LENS & LEGENDS

Lens available in 2 sizes and 6 standard colors in either translucent or transparent materials. Numerous symbols and text available for imprinting or laser etching.

## ACTUATOR

Available in rocker or paddle styles. Several standard color options also available.

## ROLLER PIN

Eliminates need for lubricants, increasing the temperature range of the switch from  $-40^{\circ}\text{C}$  to  $+85^{\circ}\text{C}$  [ $-40^{\circ}\text{F}$  to  $185^{\circ}\text{F}$ ].

## BASE

Fits into industry standard mounting hole of 1.734 x .867 in [44.0mm x 22.0mm].

# Tech Specs

## Electrical

Contact Rating	4VA @ 24VDC (MAX) resistive 15 amps, 125VAC 10 amps, 250VAC 20 amps, 4-14VDC 15 amps, 15-28VDC
Dielectric Strength	1250 Volts RMS between pole to pole 3750 Volts RMS between live parts and accessible surfaces
Insulation Resistance	50 Megohms
Initial Contact Resistance	10 milliohms max. @ 4 VDC
Life	Up to 100,000 cycles maintained, 50,000 cycles momentary circuit and load dependent
Contacts	90/10 silver-nickel, silver tin-oxide, gold
Terminals	Brass or copper/silver plate 3/16" (4.76mm) & 1/4" (6.3mm) Quick Connect terminations standard.

## Physical

Lighted	Incandescent - rated 10,000 hours LED - rated 100,000 hours 1/2 life (LED is internally ballasted for voltages to 24 VDC)
Seals	Rocker, base & bracket are sealed.
Base	Nylon 66 GF rated to 85°C with a flammability rating of 94V0.
Actuator	Basic actuator structure molded of thermoplastic polycarbonate with a hard Nylon 66 thermoplastic surface overlay.
Locks	Acetal
Lens	Polycarbonate rated at 100°C
Function	2 & 3 Position Rocker Style
Bracket	Nylon Zytel
Connector	Nylon 66 rated at 85°C. Polarized.

## Actuator Travel (Angular Displacement)

2 Position	26°
3 Position	13° from center

## Environmental

Sealing	IP67, for above-panel components of actual switch only
Corrosion	Mixed Flowing Gas MFG Class III per ASTM B-827 & B-845, Method H, with 3 years exposure.
Operating Temp	-40°C to + 85°C
Vibration 1	Per Mil-Std 202F, Method 204D Test Condition A 0.06 DA or 10G's 10-500 Hz. Tested with VCH connector. Test criteria - No loss of circuit during test and pre and post test contact resistance.
Vibration 2	Resonance search 24-50 Hz 0.40 DA 50-2000 ±10 G's peak Results Horizontal Axis 3-5 G's max. Random 24 Hz 0.06 PSD-Gsq/Hz 60 Hz 0.50 100 Hz 0.50 200 Hz 0.025 2000 Hz 0.025 No loss of circuit during test; <10µ chatter.
Shock	Per Mil-Std 202F, Method 213B, Test Condition K @ 30G's. Tested with VCH connector. Test criteria - No loss of circuit during test, pre, and post test contact resistance.
Salt Spray	Per Mil-Std 202F, Method 101D, Test Condition A, 48 Hrs.
Thermal Shock	Per Mil-Std 202F, Method 107F, Test Condition A, -55°C to 85°C. Test criteria - pre and post test contact resistance.
Moisture Resistance	Per Mil-Std 202F, Method 106F, Test Criteria - pre and post test contact resistance.

## Mounting Specifications

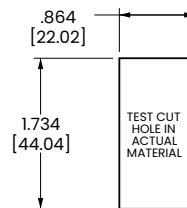

MOUNTING HOLE

**Panel Thickness Range**  
Acceptable Panel Thickness  
.030 to .156 (.76mm to 3.96mm)  
Recommended:  
.030, .062, .093, .125 and .156

# Ordering Scheme Rocker

Sample Part Number

**L 11 E 3 C H N 1-3 A A 45-1 48**

Selection 1 2 3 4 5 6 7 8 9 10 11 12 13 14

## 1. SERIES

L

## 2. CIRCUIT

Terminal Orientation



( ) - momentary  
 SP - single pole - uses terminals 1, 2 & 4.  
 DP - double pole uses terminals 5, 6 & 8.  
 Terminals 9, 10 & 11 for lamp circuit only.

<b>Position:</b>	<b>1</b>	<b>2</b>	<b>3</b>	
SP	DP	2 & 4, 6 & 8	Connected Terminals	1 & 2, 5 & 6
11	21	ON	NONE	OFF
12	22	(ON)	NONE	OFF
13	23	ON	NONE	(OFF)
14	24	ON	NONE	ON
15	25	ON	NONE	(ON)
16	26	ON	OFF	ON
17	27	ON OFF	(ON)	
18	28	(ON)	OFF	(ON)
<b>CIRCUITS WITH JUMPER TERMINALS</b>				
30*	(2,4&5), (1,6&8)	OFF, OFF		(1,2&8), (4,5&6)
31*	1, 2 & 5	2, 3 & 7		2, 4 & 8
<b>PROGRESSIVE CIRCUITS</b>				
51		3 & 4		1 & 2
52		3 & 4		OFF
53		(3 & 4)		1 & 2
54		(3 & 4)		(OFF)
55		(3 & 4)		(1 & 2)
56		(3 & 4)		(OFF)
57		3 & 4		(OFF)
58*		2 & 4		1 & 2
61		3 & 4, 7 & 8	2 & 3, 6 & 7	1 & 2, 5 & 6
62		3 & 4, 7 & 8	2 & 3, 6 & 7	OFF, OFF
63		(3 & 4), (7 & 8)	2 & 3, 6 & 7	1 & 2, 5 & 6
64		(3 & 4), (7 & 8)	2 & 3, 6 & 7	OFF, OFF
65		(3 & 4), (7 & 8)	2 & 3, 6 & 7	(1 & 2), (5 & 6)
66		(3 & 4), (7 & 8)	2 & 3, 6 & 7	(OFF, OFF)
67		3 & 4, 7 & 8	2 & 3, 6 & 7	(OFF, OFF)
68		2 & 4, 7 & 8	2 & 4, OFF	OFF, OFF
69*		2 & 4, 1, 7 & 8	2 & 4, OFF	OFF, OFF
70		(2 & 4), (7 & 8)	2 & 4, 5 & 7	(1 & 2), (5 & 7)
71		(2&4), (7 & 8)	2 & 4, 5 & 7	1 & 2, 5 & 7
72		2 & 4, 7 & 8	2 & 4, 5 & 7	1 & 2, 5 & 7
73		(2 & 4), (7 & 8)	2 & 4, OFF	OFF, OFF
80		2 & 4, 6 & 8	2 & 4, OFF	OFF, 5 & 6
<b>HAZARD WARNING CIRCUITS</b>				
A2		6, 7 & 8, 3 & 4	NONE	OFF, 1 & 2
A3		6, 7 & 8, 2 & 4	NONE	OFF, 1 & 2

\* Available with ratings 1, B, & E only.

## 3. RATING

2

1	.4VA @ 28VDC Resistive	E	15A 12V
B	15A 24V	G	20A 6V
C	20A 18V	H	20A 3V
D	20A 12V		

## 4. TERMINATION

2,3

- 1 .250 (6.4mm) TAB (QC)
- 3 .187 (4.7mm) TAB (QC)

Do not use silicone based lubricants to reduce terminal insertion forces during connector assembly, as it is detrimental to function and performance.

## 5. ILLUMINATION

Lamp #1 above terminals 9 & 10 end of switch; Lamp #2 above terminals 11 & 12 end of switch. Positive (+) and negative (-) symbols apply to LED lamps only.

	Lamps	Illumination Type	Lamp Wired to Terminals
S	None		
A	# 1	Independent	10+ 9-
B	# 2	Independent	12+ 11-
C	# 1	Independent	10+ 9-
	& # 2	Independent	12+ 9-
D	# 1	Dependent	4+ 9-
E	# 1	Independent	10+ 9-
	& # 2	Dependent	4+ 9-
F <sup>4</sup>	# 1	Independent	10+ 9-
	& # 2	Dependent	8+ 9-
G	# 1	Dependent	4+ 9-
	& # 2	Independent	10+ 9-
H	# 1	Both Independent	10+ 9-
	& # 2	(in series)	
J	# 1	Dependent	4+ 9-
	& # 2	Dependent	1+ 9-
1	# 2	Hazard	6+ 10- 12-
2	# 1	Hazard	6+ 10- 12-

## 6,7. LAMP (SAME CODING FOR BOTH SELECTIONS)

Selection 6: above terminals 10 & 9; Selection 7: above terminals 12 & 11

No lamp	0			
Incandescent	4	3V	5 6V	6 12V
LED*		Red	Amber	Green
2VDC	A	L	F	
6VDC	B	M	G	
12VDC	C	N	H	
24VDC	D	P	J	

\* Consult factory for "daylight bright", blue/green and white LED options. Typical current draw for LED is 20ma.

## 8. BRACKET COLOR

1

Black	White	Gray	Red	
Standard Bracket	1	2	3	4
Rockerguard at Lamp 1	A	B	C	D
Rockerguard at Lamp 2	E	F	G	H

## 9. ACTUATOR STYLE AND COLOR

1

Rocker	Black	White	Gray	Red	Laser Etched
Paddle	A	B	C	D	3
	J	N	K	M	4

## 10 & 11. LENS STYLE AND COLOR

Lens color for LEDs must be clear, white, or match color of LED.  
 0 - No Actuator Z - No Lens

Clear	White	Amber	Green	Red	Blue	
1	-	B	G	M	T	Large Transparent
-	7	C	H	N	U	Large Translucent
3	-	D	J	P	V	Bar Transparent
-	9	E	K	R	W	Bar Translucent
5	A	-	-	-	-	Laser Etched background color

## 12. LASER ETCHED, LENS OR BODY LEGEND

00 No legend

For standard legends, see "Standard Legend Codes" page. For additional legends, please consult factory

## 13. LEGEND ORIENTATION

- 0 No legend (used with codes 11-18 in selection 12)
- 1 Orientation 1 - vertical, lamp 1 on top
- 2 Orientation 2 - horizontal, lamp 1 on right
- 3 Orientation 3 - vertical, lamp 1 on bottom
- 4 Orientation 4 - vertical, lamp 1 on left

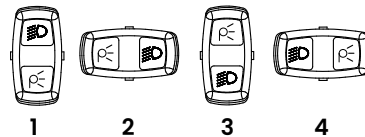

## 14. ACTUATOR LENS LEGEND

00 No legend

For standard legends, see "Standard Legend Codes" page. For additional legends, please consult factory

Notes: Consult factory to verify horsepower rating for your particular circuit choice.

- 1 Custom colors are available. Consult factory.
- 2 Circuits 30, 31, 58, 69 are not available with rating codes 4, C, D, G or H.
- 3 Termination 3 only available with rating codes 1, B, and E.
- 4 Not available with circuits 11-18, 51-57 and 69.

[Configure Complete Part Number >](#)

[Browse Standard Parts >](#)

# Ordering Scheme Locking Rocker

Sample Part Number

**L 11 D 1 S W C J - P M H 00 - 0**

Selection 1 2 3 4 5 6 7 8 9 10 11 12 13

## 1. SERIES

L

## 2. CIRCUIT <sup>5</sup>

Terminal Orientation



( ) - momentary  
 SP - single pole - uses terminals 1, 2 & 4.  
 DP - double pole uses terminals 5, 6 & 8.  
 Terminals 9, 10 & 11 for lamp circuit only.

Position:	1	2	3
SP DP	2 & 4, 6 & 8	Connected Terminals	1 & 2, 5 & 6
11 21	ON	NONE	OFF
14 24	ON	NONE	ON
16 26	ON	OFF	ON
17 27	ON	OFF	(ON)
18 28	(ON)	OFF	(ON)

CIRCUITS WITH JUMPER TERMINALS

30 <sup>2</sup>	(2,4&5), (1,6&8)	OFF, OFF	(1,2&8), (4,5&6)
31 <sup>2</sup>	1, 2 & 5	2, 3 & 7	2, 4 & 8

PROGRESSIVE CIRCUITS

51	3 & 4	2, 3	1 & 2
52	3 & 4	2, 3	OFF
53	(3 & 4)	2, 3	1 & 2
54	(3 & 4)	2, 3	(OFF)
55	(3 & 4)	2, 3	(1 & 2)
56	(3 & 4)	2, 3	(OFF)
57	3 & 4	2, 3	(OFF)
58	2 & 4	2, 3	1 & 2
61	3 & 4, 7 & 8	2 & 3, 6 & 7	1 & 2, 5 & 6
62	3 & 4, 7 & 8	2 & 3, 6 & 7	OFF, OFF
63	(3 & 4), (7 & 8)	2 & 3, 6 & 7	1 & 2, 5 & 6
64	(3 & 4), (7 & 8)	2 & 3, 6 & 7	OFF, OFF
65	(3 & 4), (7 & 8)	2 & 3, 6 & 7	(1 & 2), (5 & 6)
66	(3 & 4), (7 & 8)	2 & 3, 6 & 7	(OFF, OFF)
67	3 & 4, 7 & 8	2 & 3, 6 & 7	(OFF, OFF)
68	2 & 4, 7 & 8	2 & 4, OFF	OFF, OFF
69	2 & 4, 1, 7 & 8	2 & 4, OFF	OFF, OFF
70	(2 & 4), (7 & 8)	2 & 4, 5 & 7	(1 & 2), (5 & 7)
71	(2 & 4), (7 & 8)	2 & 4, 5 & 7	1 & 2, 5 & 7
72	2 & 4, 7 & 8	2 & 4, 5 & 7	1 & 2, 5 & 7
73	(2 & 4), (7 & 8)	2 & 4, OFF	OFF, OFF
80	2 & 4, 6 & 8	2 & 4, OFF	OFF, 5 & 6

## 3. RATING <sup>2</sup>

1	.4VA @ 28VDC Resistive	E	15A 12V
B	15A 24V	G	20A 6V
C	20A 18V	H	20A 3V
D	20A 12V		

## 4. TERMINATION <sup>4</sup>

1 .250 (6.4mm) TAB (QC)  
 3 .187 (4.7mm) TAB (QC)  
 Do not use silicone based lubricants to reduce terminal insertion forces during connector assembly, as it is detrimental to function and performance.

## 5. ILLUMINATION

Lamp #1: above terminals 9 & 10 end of switch; Lamp #2 above terminals 11 & 12 end of switch. Positive (+) and negative (-) symbols apply to LED lamps only.

Lamps	illumination Type	Lamp Wired to Terminals
S	None	
B	# 2 Independent	12+ 11-

## 6. LOCK

W Lock above terminals 10 & 9.

## 7. LAMP

No lamp	0				
Incandescent	4 3V	5 6V	6 12V	7 18V	8 24V
LED*	Red	Amber	Green		
2VDC	A	L	F		
6VDC	B	M	G		
12VDC	C	N	H		
24VDC	D	P	J		

\* Consult factory for "daylight bright", blue/green and white LED options.  
 Typical current draw for LED is 20ma.

## 8. BRACKET COLOR <sup>1</sup>

J Black

## 9. ACTUATOR STYLE AND COLOR <sup>1</sup>

	Black	Red
Locking Rocker	P	R

## 10 & 11. LENS STYLE AND COLOR

Lens color for LEDs must be clear, white, or match color of LED.  
 0 - No Actuator Z - No Lens

Clear	White	Amber	Green	Red	Blue
1	-	B	G	M	T
-	7	C	H	N	U
3	-	D	J	P	V
-	9	E	K	R	W

Large Transparent  
 Large Translucent  
 Bar Transparent  
 Bar Translucent

## 11. LOCK FUNCTION AND COLOR

Locking Position	Up	Down	Up & Down	Center <sup>3</sup>	Lock Color
A	H	R		1	Match Actuator
B	J	S		2	Black
C	K	T		3	White
D	L	V		4	Red
E	M	W		5	Safety Orange

## 12. LASER ETCHED, LENS OR BODY LEGEND

00 No legend  
 For standard legends, see "Standard Legend Codes" page.  
 For additional legends, please consult factory

## 13. LEGEND ORIENTATION

0 No legend (used with codes 11-18 in selection 12)  
 1 Orientation 1 - vertical, lamp 1 on top  
 2 Orientation 2 - horizontal, lamp 1 on right  
 3 Orientation 3 - vertical, lamp 1 on bottom  
 4 Orientation 4 - vertical, lamp 1 on left

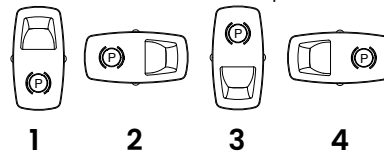

Notes: Consult factory to verify horsepower rating for your particular circuit choice.  
 1 Custom colors are available. Consult factory.  
 2 Additional lamp circuits available. Consult factory.  
 3 Available only with 3 position circuits.  
 4 Termination 3 only available with ratings 1, B and E.  
 5 Circuits 30, 31, 58 and 69, are not available with rating codes 4, C, D, G or H.

[Configure Complete Part Number >](#)

[Browse Standard Parts >](#)

# Dimensional Specs

inches [millimeters]

**L-SERIES**  
SHOWN WITH LASER ETCHED  
ACTUATOR

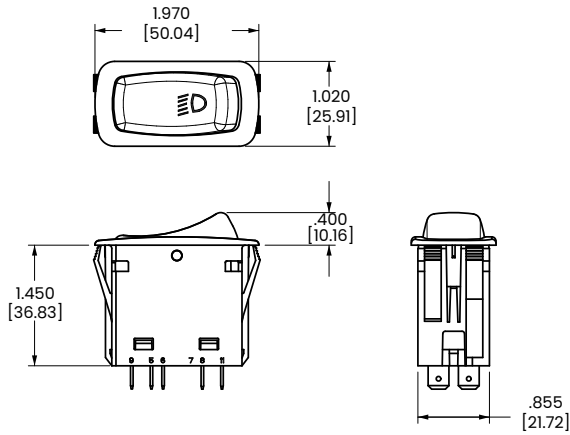

**L-SERIES**  
SHOWN WITH ROCKER GUARD

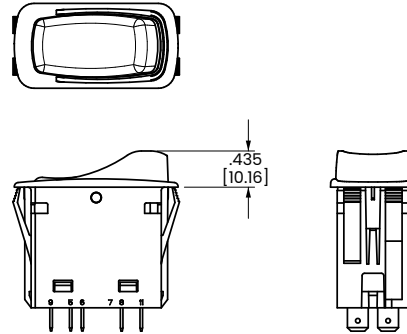

**L-SERIES**  
SHOWN WITH LARGE LENS  
AND PADDLE ACTUATOR

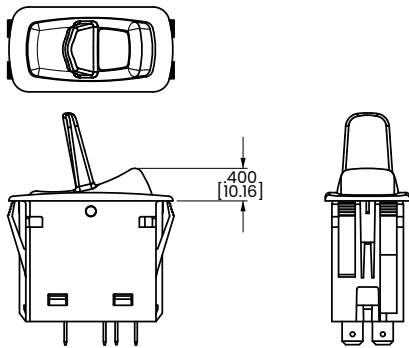

**L-SERIES**  
SHOWN WITH BAR LENS, LOCK  
AND CONNECTOR

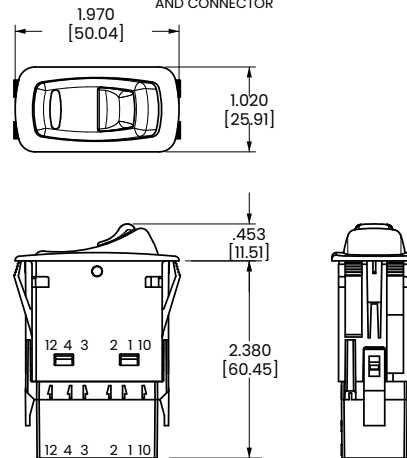

## Connector

**L-SERIES**  
CONNECTOR

- LC1-01** BLACK .250 TAB CONNECTOR (PACKARD 630 SERIES)
- LC2-01** BLACK .187 TAB CONNECTOR (PACKARD 480 SERIES)
- LC3-01** BLACK .250 TAB CONNECTOR (AMP ONLY)

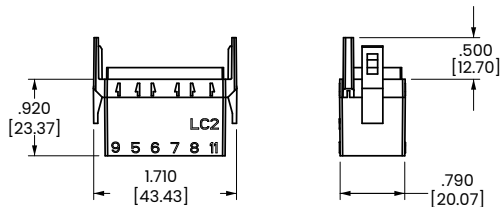

## Hole Plug

**L-SERIES**  
HOLE PLUG

- LH1** REMOVABLE HOLE PLUG WITH NON-SERRATED WINGS
- LH2** HOLE PLUG WITH SERRATED WINGS

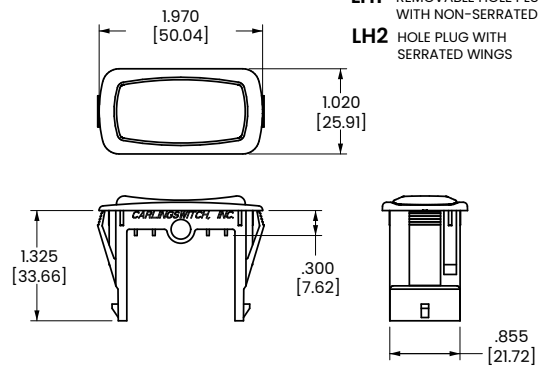

# Dimensional Specs

inches [millimeters]

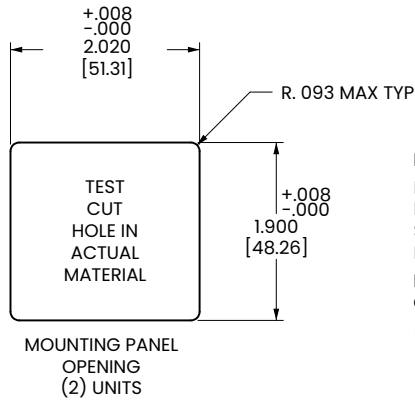
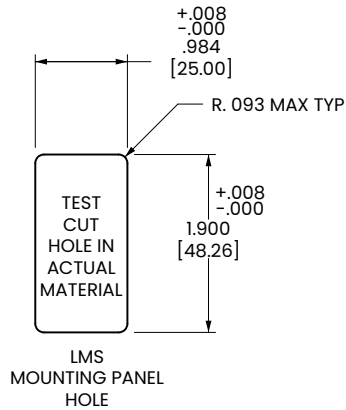

MOUNTING PANEL  
 FOR ADDITIONAL UNITS < ADD 1.03 [26.2] PER UNIT.  
 FOR MORE THAN 2 L-SERIES SWITCHES, ADD MIDDLE SECTION. AVAILABLE IN PANEL THICKNESSES LISTED BELOW > CONSULT FACTORY  
 DIMENSIONS: LME 2.02 [51.3mm] PLUS NUMBER OF CENTER BEZELS (LMM) X 1.034 [26.26mm]  
 MOUNTING PANEL THICKNESS  
 .062 .093 .125 .156  
 [1.57] [2.36] [3.17] [3.96]

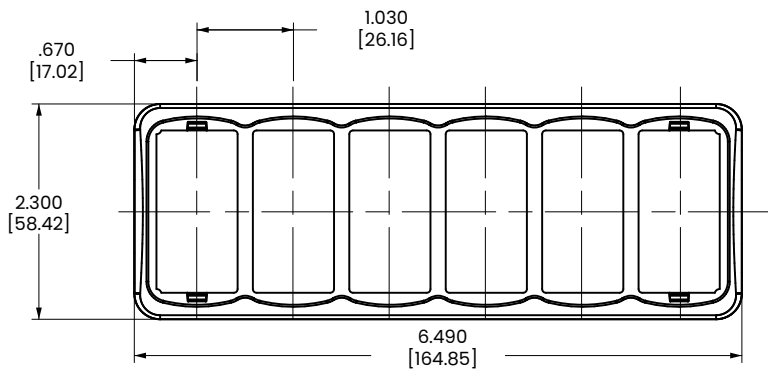
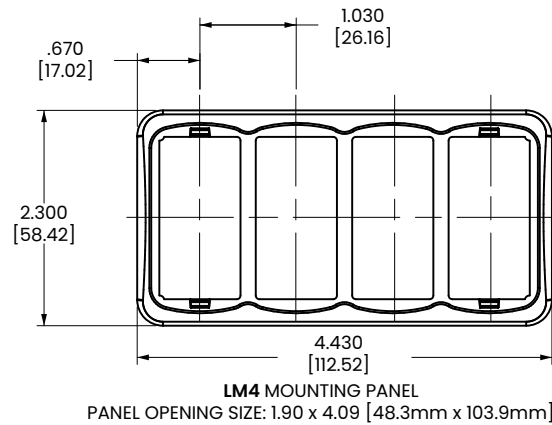
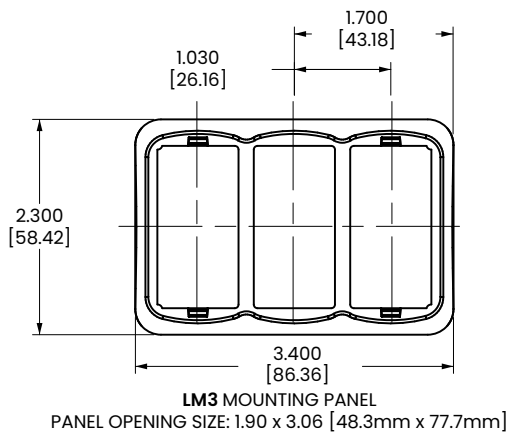
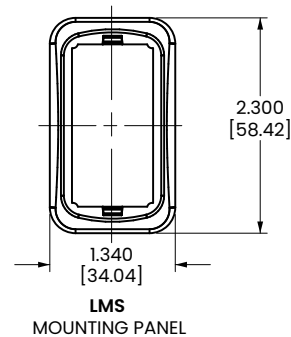
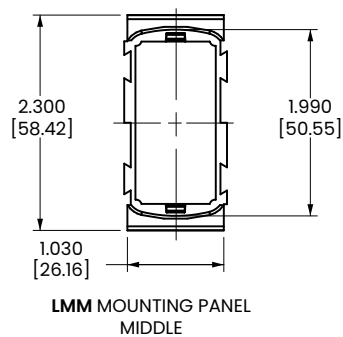
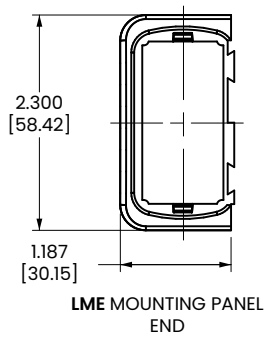

# Circuit Diagrams

CIRCUIT CODE	CIRCUIT DIAGRAM	CIRCUIT CODE	CIRCUIT DIAGRAM	CIRCUIT CODE	CIRCUIT DIAGRAM
11		22		51	
12		23		52	
13		24		53	
14		25		54	
15		26		55	
16		27		56	
17		28		57	
18		30		58	
21		31		61	



# Circuit Diagrams

CIRCUIT CODE	CIRCUIT DIAGRAM	CIRCUIT CODE	CIRCUIT DIAGRAM
62		71	
63		72	
64		73	
65		80	
66		81	
67		82	
68		A2	
69		A3	
70			

# Lamp Circuit Diagrams

LAMP CIRCUIT CODE	CIRCUIT DIAGRAM
A	
B	
C	
D	
E	
F	
G	
H	

LAMP CIRCUIT CODE	CIRCUIT DIAGRAM
J	
I	
2	
K	

LEGEND	
SYMBOL	DEFINITION
	TERMINAL LOCATION
	LAMP LOCATION
	MAINTAINED CIRCUIT
	MOMENTARY CIRCUIT
	INTERNAL CONNECTION (JUMPER TERMINAL)
	2 POSITION CONNECTION
	2 POSITION
	3 POSITION

# Standard Legend Codes

YK	UA	UB	US	UV	UW	UX	UY	MP	MR	PX	MS	MT
VU	MW	NZ	NX	NY	YM	VW	PS	PW	PZ	WG	WM	RN
RP	YG	TX	VD	VE	VF	VG	SH	SM	SN	SP	SR	SY
DIM	BRIGHT	UH	UJ	PD	PE	PF	VC	VJ	UF	UG	MU	TN
NS	PB	SE	VZ	YE	NN	RW	PU	WA	YN	UE	NM	RJ
NR	YD	TL	VR	SL	VA	UC	VN	PK	VY	UZ	RH	NU
NV	RB	RC	RK	RL	MZ	RG	UP	DOWN	UD	UR	WD	TY
PA	UK	WR	UU	UT	YR	PM	VV	WB	TB	TC	TD	TE
MY	PV	TA	TZ	WC	PT	PN	PH	RA	TU	TT	YL	SK
VS	UL	UM	WK	TS	VT	WL	VP	YJ	PJ	RY	UP	NW
NP	RE	RF	PP	PR	TV	PC	YT	YU	PL	WJ	MV	RR
TK	RT	SZ	VX	WF	WH	PG	SJ	YA	YB	RM	TM	RD
RS	UN	TP	TR	NT	MX	YC	TW	TJ	YF	TH	TF	TG
YS	YH	SX	RZ	YP	WN	WP	WW	WX	SA	SB	SC	SD
RAISE	LOWER	HIGH	LOW	FWD	REV	DEPTH	TRIM TAB	ACC	NAV ANCH	WIND LASS UP/DN	LIVE WELL	REAR
ST	SU	WU	WV	SV	SW	VB	VH	VK	VL	VM	WE	SF
PARK	AUTO	RU	RV	RX								
SG	SS											

## Authorized Sales Representatives and Distributors

Click on a region of the map below to find your local representatives and distributors or visit [www.carlingtech.com/findarep](http://www.carlingtech.com/findarep).



## About Carling

Founded in 1920, Carling Technologies is a leading manufacturer of electrical and electronic switches and assemblies, circuit breakers, electronic controls, power distribution units, and multiplexed power distribution systems. With six ISO9001 and IATF16949 registered manufacturing facilities and technical sales offices worldwide, Carling Technologies Sales, Service and Engineering teams do much more than manufacture electrical components, they engineer powerful solutions! To learn more about Carling please visit [www.carlingtech.com/company-profile](http://www.carlingtech.com/company-profile).

To view all of Carling's environmental, quality, health & safety certifications please visit [www.carlingtech.com/environmental-certifications](http://www.carlingtech.com/environmental-certifications).

## X-ON Electronics

Largest Supplier of Electrical and Electronic Components

*Click to view similar products for [Switch Fixings](#) category:*

*Click to view products by [Carling](#) manufacturer:*

Other Similar products are found below :

[893102000](#) [00-5150](#) [LZZ1A](#) [0098.9234](#) [61-9451.0](#) [M2PA-5011](#) [630155](#) [635401](#) [6PA113](#) [6PA147-E6](#) [6PA148-E6](#) [6PA32](#) [6PA9](#) [700109](#)  
[700303A56](#) [700C1GRY](#) [700C2GRN](#) [704-6001](#) [704.960.4](#) [704.960.9](#) [704.965.2](#) [704.965.6](#) [704.966.0](#) [7089-3](#) [710082-B11](#) [71M1048](#)  
[757200264](#) [764300000](#) [MHU35](#) [MHU37](#) [807039-1](#) [825.003.011](#) [825.005.011](#) [825.053.011](#) [825.055.011](#) [826.000.071](#) [827.020.011](#)  
[827.400.021](#) [835.900.023](#) [MML52C10C](#) [MML52E10C](#) [MML92HGH](#) [MML93K](#) [84211M02CNNS](#) [84212M02CNNS](#) [84217A8.0LNOS](#)  
[842.500.011](#) [843.000.011](#) [843187-000](#) [843487-000](#)