

Fiber Optic Sensor Amplifier Type FA1

CARLO GAVAZZI



- Distance range is fiber dependent
Please see the FUR, FUT datasheet
- Easy set-up using 3-ways adjustment switch
- 2 X 4 digits display to show signal level and threshold
- Display direction can be inverted to suit different mounting
- Output 100mA NPN or PNP
- Light on and dark on switching selectable
- Operational voltage 12 to 24 VDC
- On, off, on one shot, off one shot delay timer
- Response time 200, 500, 1000, 5000µs



Product Description

FA1 series amplifier is a fiber optic amplifier most suitable to be used with FUR/FUT fibers to achieve various detection distance.

FA1 has a 2 x 4 digits LED display to show the signal level and threshold respectively. Display direction can be inverted to suit different installation needs.

FA1 is also equipped with a 3-ways adjuster switch to adjust sensitivity and different response time.

The sensor output is either NPN or PNP and is selectable to be light on or dark on. There is also a timer for the output which can be selected to be on delay, off delay, on one shot and off one shot to suit most applications' needs.

Ordering Key FA 1-N

Type _____
Series _____
Output _____

Type Selection

Housing
W x H x D

10 x 33 x 80 mm

Ordering no.
NPN
Light on or dark on switching

FA1-N

Ordering no.
PNP
Light on or dark on switching

FA1-P

Specifications

Rated operating distance (S_n)	Fiber dependant Please see FUR, FUT datasheet	Output function Light on or dark on	NPN or PNP Selected via switch
Sensitivity	Increase or decrease by 3-ways adjuster switch. Switch left/right to +/- and press down to confirm	Timer Type	On, off, on one shot, off one shot
Sensitivity Range	Depends on selected response time 27-3991 @200µs 27-3982 @500µs 27-9988 @1000µs 27-9990 @5000µs	Range	0-9999 ms
Temperature drift	< 0.2%/C°	Current consumption (I_o)	< 40 mA @ 24 VDC
Hysteresis (H)	≤ 20% of sensing distance	Voltage drop (U_d) FA1-N FA1-P	≤1V (100 mA Load) ≤1.5V (100 mA Load)
Rated operational volt. (U_B)	12 to 24 VDC	Protection	Short-circuit, reverse polarity, transients
Ripple (U_{rpp})	≤ 10%	Light source	Red LED 660 nm
Output current Continuous (I _a)	100 mA	Ambient light Incandescent light Sunlight	10'000 Lux 20'000 Lux
		Operating frequency	Max. 2.5 kHz
		Response time	Selectable 200, 500, 1000, 5000µs



Specifications (cont.)

Power ON delay (t_v)	< 150 ms
Indication	Red LED
Output	2 X 4 digits display
Sensitivity	Red – signal level Green - threshold
Temperature	
Operating	0° to +60°C (32° to +140°F)

Housing material	
Body	ABS
Connection	
Cable	PVC, black, 2m, 3 wires
Weight	Approx. 65g
Approvals	CE, cULus (UL508)
Environment	
Degree of protection	IP40

Operation Diagram

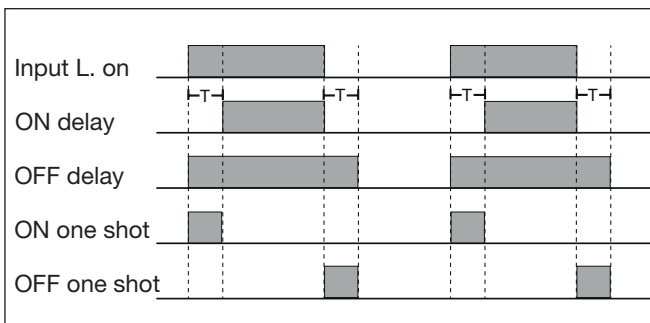

Wiring Diagram

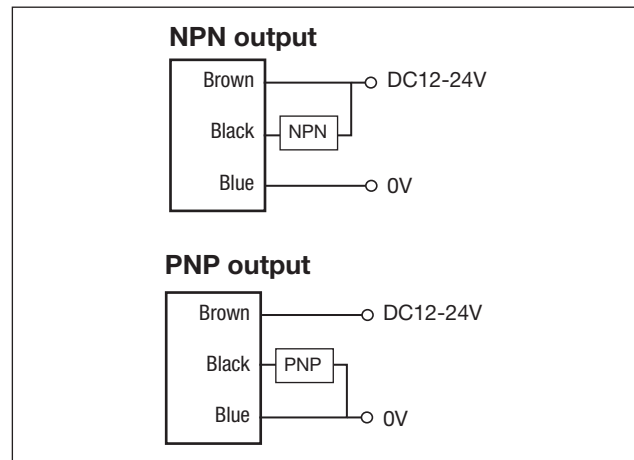

Dimensions

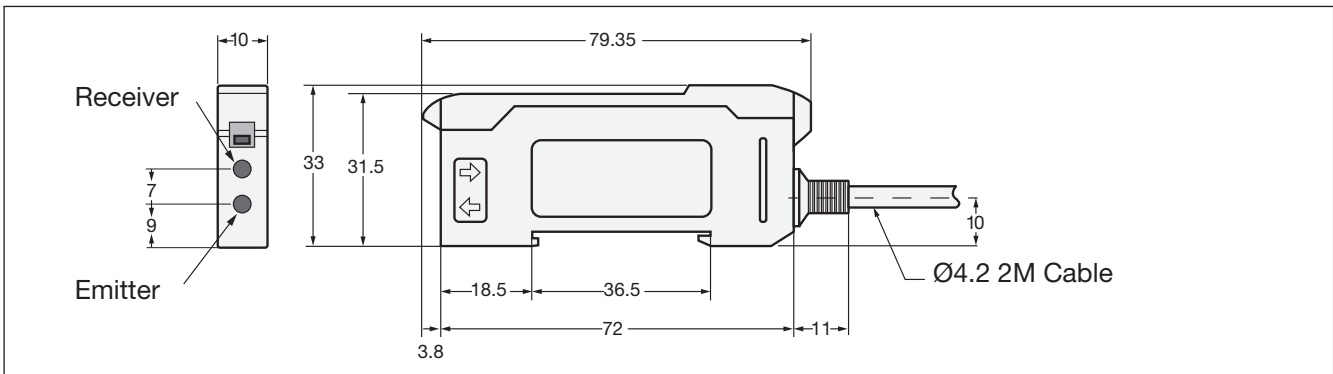

LED and Operation Panel

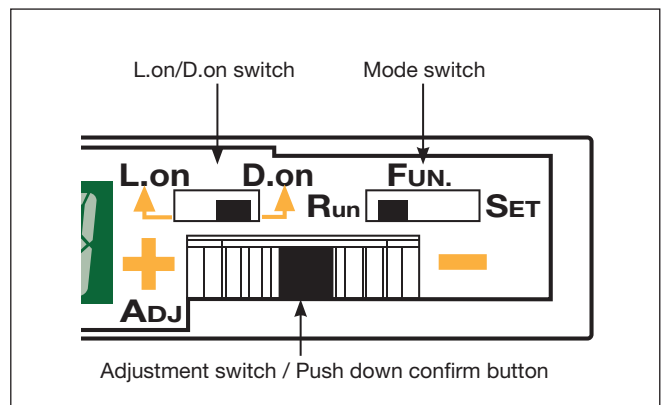
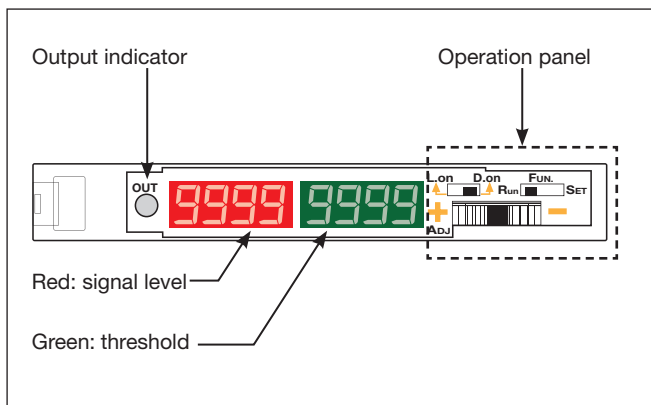

Block Diagram - Programming Settings

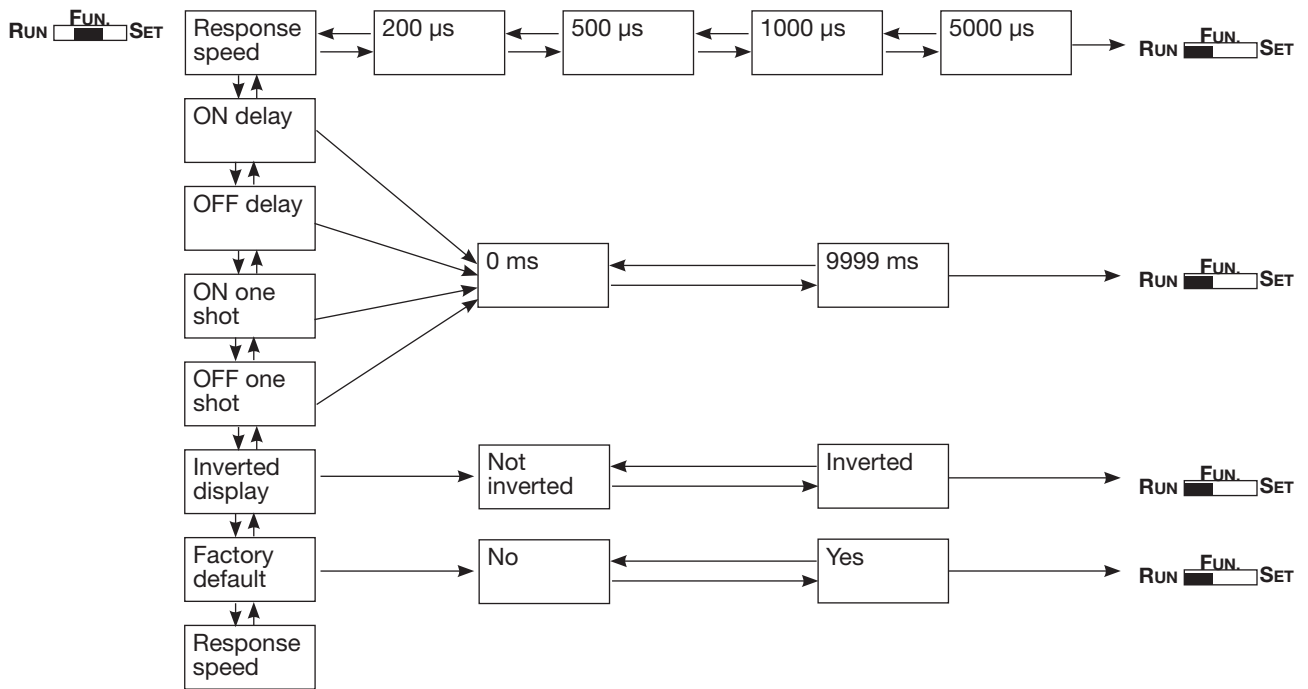



Programming Functions

<p>Settings</p>	<p>Mode switch: Select FUN. RUN FUN SET</p>	<p>Inverted display</p>	<p>dISP rERd Press ADJ for 2 sec.</p>
<p>Response speed</p> <p>Higher response time: shorter sensing distance. Lower response time: longer sensing distance.</p>	<p>rESP SPd Press ADJ for 2 sec.</p> <p>Turn to '+' to increase or '-' to decrease response time</p> <p>200 µS ↔ 500 µS 1000 µS ↔ 5000 µS</p> <p>Press ADJ for 2 sec. Return to RUN RUN FUN SET</p>	<p>Turn to '+' to increase or '-' to change between displays</p> <p>dISP 1234 ↔ hE21 dS'P</p> <p>Press ADJ for 2 sec. Return to RUN RUN FUN SET</p>	<p>Press ADJ for 2 sec. Return to RUN RUN FUN SET</p>
<p>ON delay</p> <p>OFF delay</p> <p>ON one shot</p> <p>OFF one shot</p>	<p>Setting delay time: 0-9999 ms</p> <p>On dEL OFF dEL On !Sht OFF !Sht</p> <p>Turn to '+' to increase or '-' to decrease delay time</p> <p>0 ↔ 9999</p> <p>Press ADJ for 2 sec. Return to RUN RUN FUN SET</p>	<p>Factory default</p> <p>FctY dEF Press ADJ for 2 sec.</p> <p>Turn to '+' to increase or '-' to change between options (Yes/No)</p> <p>no ↔ YES</p> <p>Press ADJ for 2 sec. Return to RUN RUN FUN SET</p>	<p>Press ADJ for 2 sec. Return to RUN RUN FUN SET</p>



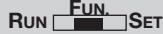

Programming Functions - Example

Setting example

Set OFF delay to 2 sec.

- Select FUN.

- Turn to '+' to or '-' to go to OFF delay mode

- Hold down for two sec.

The display shows '0'

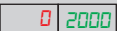
- Turn to '+' to set to 2000

- Hold down for two sec. to confirm setting (OFF delay)

- Return to RUN



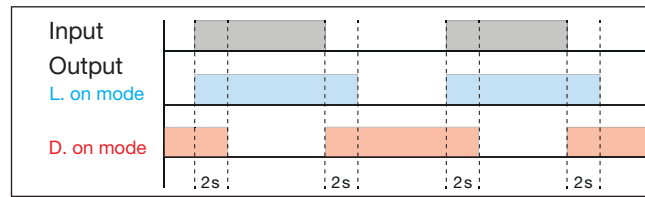

Working position is now:





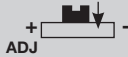

OFF delay 2 sec.



Diffuse model settings

- Set to L.on

- Select SET

- With target: hold down ADJ for 2 sec. Auto-teach-in function is performed when the blinking stops. (see fig. 1, p. 5)

- Return to RUN

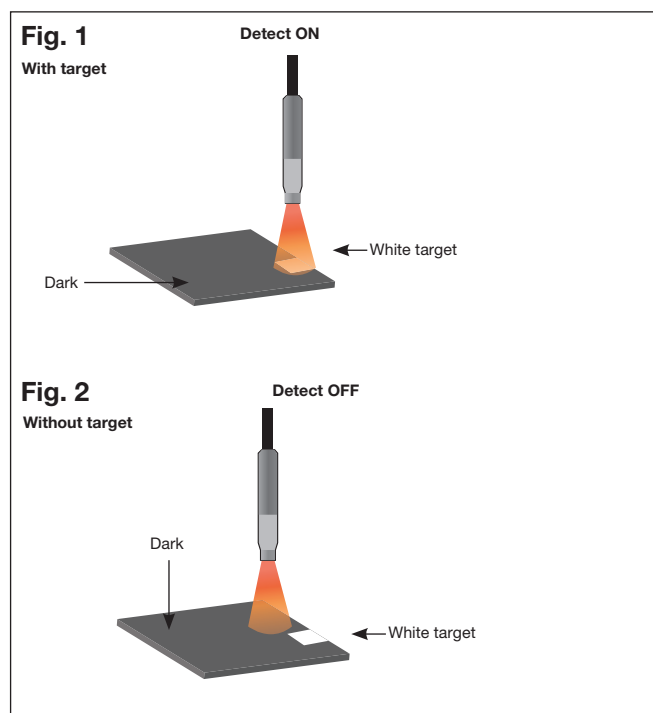
- If reversed operation detection is required, change to D.on

Through-beam model settings

- Set to D.on

- Select SET

- Without target; hold down ADJ for 2 sec. Auto-teach function is performed when the blinking stops. (see fig. 3, p. 5)

- Return to RUN

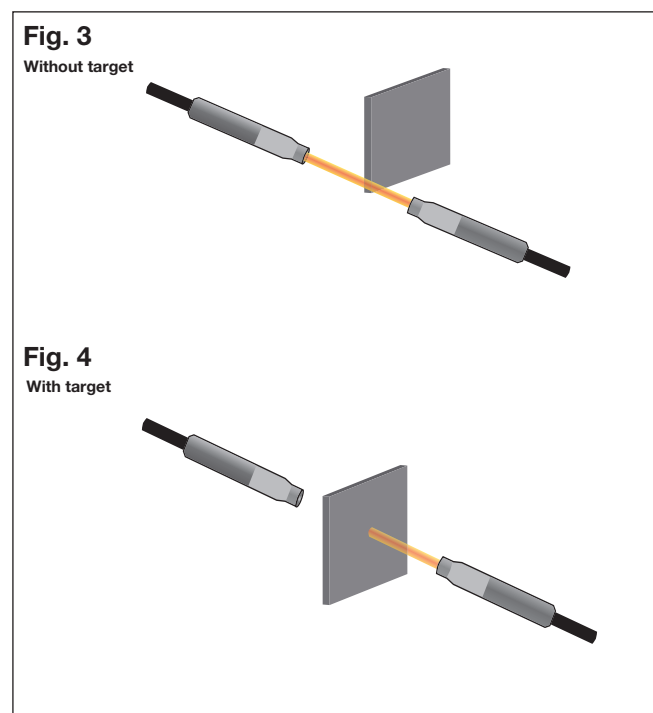
- If reversed operation detection is required, change to L.on

Diffuse model settings



Through-beam model settings



Installation Hints

<p>Mounting the amplifier</p> <p>Mount each amplifier to the attached mounting bracket or DIN rail in sequence.</p> <p>Claw tenon DIN rail</p>		<p>Detaching the amplifier</p> <p>Detach the amplifiers in sequence by sliding the amplifier bodies.</p>	<p>Detach the amplifier,</p> <p>NB: Do not detach two amplifiers at a time.</p>
<p>Insert the fiber cables</p> <p>1. Open the protective cover.</p> <p>2. Tip the fiber lock lever to unlock.</p>	<p>3. Insert the fiber cables into the mounting holes until the limit. Insertion depth 12 mm.</p> <p>Insert</p>	<p>4. Pull the fiber lock lever back to lock the cables.</p> <p>5. Close the protective cover.</p>	<p>Remove the fiber cables</p> <p>Unlock mode Lock mode</p> <p>Pull out</p> <p>Open the protective cover and tip the fiber lock lever to unlock. Remove the cables by pulling them straight out of the mounting holes.</p>

Delivery Contents

- Amplifier: FA1...
- Installation manual
- **Packaging:** Cardboard box

Accessories

- Fiber optic plastic type FUR, FUT

For further information refer to Fiber Optic Plastic Type FUR, FUT datasheets.

X-ON Electronics

Largest Supplier of Electrical and Electronic Components

Click to view similar products for [Fibre Optic Transmitters, Receivers, Transceivers](#) category:

Click to view products by [Carlo Gavazzi](#) manufacturer:

Other Similar products are found below :

[HFBR-1532ETZ](#) [FTLX3813M354](#) [STV.2413-574-00262](#) [TRPRG1VA1C000E2G](#) [TOTX1350\(V,F\)](#) [FTLX3813M349](#) [SCN-1428SC](#) [FWLF-1519-7D-49](#) [TORX1355\(V,F\)](#) [LTK-ST11MB](#) [HFD8003-002/XBA](#) [HFD3020-500-ABA](#) [S6846](#) [SCN-2638SC](#) [FTL410QE4N](#)
[FTLC9555FEPM](#) [SCN-1570SC](#) [SCN-1601SC](#) [SCN-1338SC](#) [SFPPT-SR3-01](#) [HFD8003-500-XBA](#) [SCN-1383SC](#) [FTLC9555SEPM](#) [2333569-1](#) [LNK-ST11HB-R6](#) [FTLX6875MCC](#) [FTL4C1QL3L](#) [FTL4C1QE3L](#) [FTL4C1QL3C](#) [1019682](#) [1019683](#) [1019705](#) [HFBR-1415Z](#)
[FWLF16217D57](#) [AFBR-5803ATQZ](#) [AFBR-5803ATZ](#) [PLR135/T9](#) [TGW-Q14BB-FCQ](#) [AFBR-5803AZ](#) [TQS-Q1LH8-XCA03](#) [TQS-Q1LH8-XCA05](#) [TQS-Q1LH8-XCA10](#) [TQS-Q1LH9-2CA](#) [HFBR-1528Z](#) [HFBR-2406Z](#) [HFBR-2505AZ](#) [HFBR-1532Z](#) [HFBR-1505AZ](#) [HFBR-1415TZ](#)
[HFBR-1414TZ](#)