

# Dupline® Car Park System Type GP6220 330x 724-US 3-Colour Ultrasonic Sensor

CARLO GAVAZZI

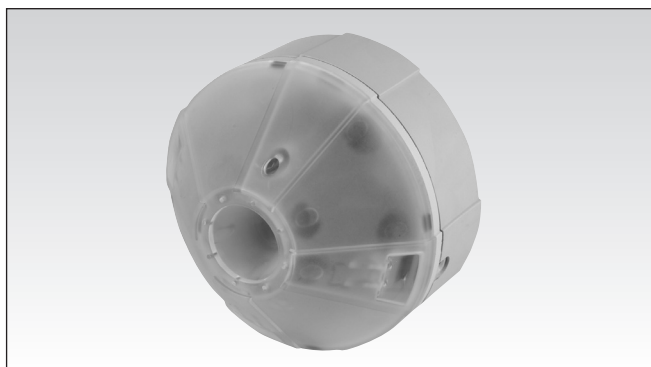

- Ultrasonic sensor with a 3-colour LED indicator
- LED colour control via the bus
- Low current consumption
- Self-calibration of the sensor can be performed globally on all sensors at once or locally on a single sensor
- Automatic temperature compensation
- Wide measuring range
- Protected against dust and moisture
- Dupline® 3-wire bus system with power
- Address coding with Carpark Configurator GP73800080
- GP6220 3301-US has a built in red/green/amber LED indicator
- GP6220 3302-US has a built in red/green/blue LED indicator
- GP6220 3303-US has a built in red/blue/amber LED indicator
- cULus approved

## Product Description

GP6220 330x 724-US is an ultrasonic sensor with a built-in 3 colour LED indicator and part of the Dupline® parking guidance system.

The GP6220 330x 724-US sensor is installed in the middle of the ceiling above the parking bay and detects whether a car is parked in the bay. The parking bay status is indicated using the built in LEDs.

The colour of the built-in LED indicator is controlled via the bus by an external device (e.g. a PC or a PLC). Different colour combinations are available to facilitate different applications. E.g. the combination red/

green/amber can be used in a parking facility with an automated booking system, and amber can indicate spaces booked for a specific event or for VIPs.

Each sensor needs to be connected to the Dupline® 3-wire bus. The bus provides power and enables the sensors to transmit the status of the parking bays to the carpark monitoring devices (GP3482 9091 724-X), which keep track of the number of free parking bays in an area and show the result on the connected displays.

## Ordering key

GP 6220 330x 724-US

Type: Dupline® \_\_\_\_\_  
 Housing \_\_\_\_\_  
 Input type \_\_\_\_\_  
 Addresses \_\_\_\_\_  
 Inputs \_\_\_\_\_  
 Supply \_\_\_\_\_

## Type Selection

- GP6220 3301 724-US Sensor with red/green/amber LED
- GP6220 3302 724-US Sensor with red/green/blue LED
- GP6220 3303 724-US Sensor with red/blue/amber LED

## Input/Output Specifications

### RJ12 connector

for address programming with Carpark Configurator GP7380 0080

### 2x3-pin connector

- Printed dot on the sensor is Dupline® +
- D- or Gnd
- POW (power from DMM or Coupler). See drawing on page 3 (System diagram)

### 1x2-pin connector

Not in use.

**NOTE:** The sensor connectors are using the “push-wire connection” methode. Use a 1.5 mm<sup>2</sup> single core wire for the sensor installation.

## Supply Specifications

Power supply:	21 VDC min.; 30 VDC max. (Overvoltage category III (IEC60664))
Max. supply current	20 mA
Nominal Supply	28 VDC / 19 mA 0,53 W



## General Specifications

<b>Ultrasonic frequency</b>	40 kHz
<b>Max. distance between ceiling and floor</b>	4.0 m
<b>Min. distance between ceiling and floor</b>	1.5 m
<b>Min. calibration distance</b>	1.5 m
<b>Hysteresis</b>	±30 cm
<b>Sensor in "Normal" mode</b>	
Sensor activations time	3 sec. See fig. 1 (Default)
<b>Sensor in "Lane" mode</b>	
Sensor activations time	0.4 sec. with a max car speed on 20 km/hour. See fig. 2
<b>Programming unit</b>	GP7380 0080
<b>Sensor temperature compensation</b>	The built-in temperature compensation makes the sensor stable and reliable without any calibration
<b>Water and condensation-resistant</b>	The bottom part plus sensor has been designed in a such a way that water entering from the ceiling flows right through the sensor and out of small holes in the transparent part of the sensor without getting in contact with the electronic board and without doing any damage.

<b>The sensor uses one Dupline® input address</b>	
• Status address	is used to transmit the status of the sensor on the bus
<b>The sensor uses 3 Dupline® output addresses</b>	
• Calibration address	is used for global calibration. Common address for all sensors on the bus
• LED CH1, LED CH2	These two addresses are used for control of the LED colour. LED CH1 = A1 LED CH2 = A2
<b>Default adress</b>	
<b>LED colour coding</b>	
GP6220 3301 724-US	
LED CH1, LED CH2 = 0,0	Green LED ON
LED CH1, LED CH2 = 0,1	Amber LED ON
LED CH1, LED CH2 = 1,0	Red LED ON
LED CH1, LED CH2 = 1,1	No LED ON
GP6220 3302 724-US	
LED CH1, LED CH2 = 0,0	Green LED ON
LED CH1, LED CH2 = 0,1	Blue LED ON
LED CH1, LED CH2 = 1,0	Red LED ON
LED CH1, LED CH2 = 1,1	No LED ON
GP6220 3303 724-US	
LED CH1, LED CH2 = 0,0	Blue LED ON
LED CH1, LED CH2 = 0,1	Amber LED ON
LED CH1, LED CH2 = 1,0	Red LED ON
LED CH1, LED CH2 = 1,1	No LED ON
<b>Approval</b>	cULus (UL60950)

In case of a Dupline® fault the sensor's red LED will start flashing at 1 second intervals.

## System Diagram

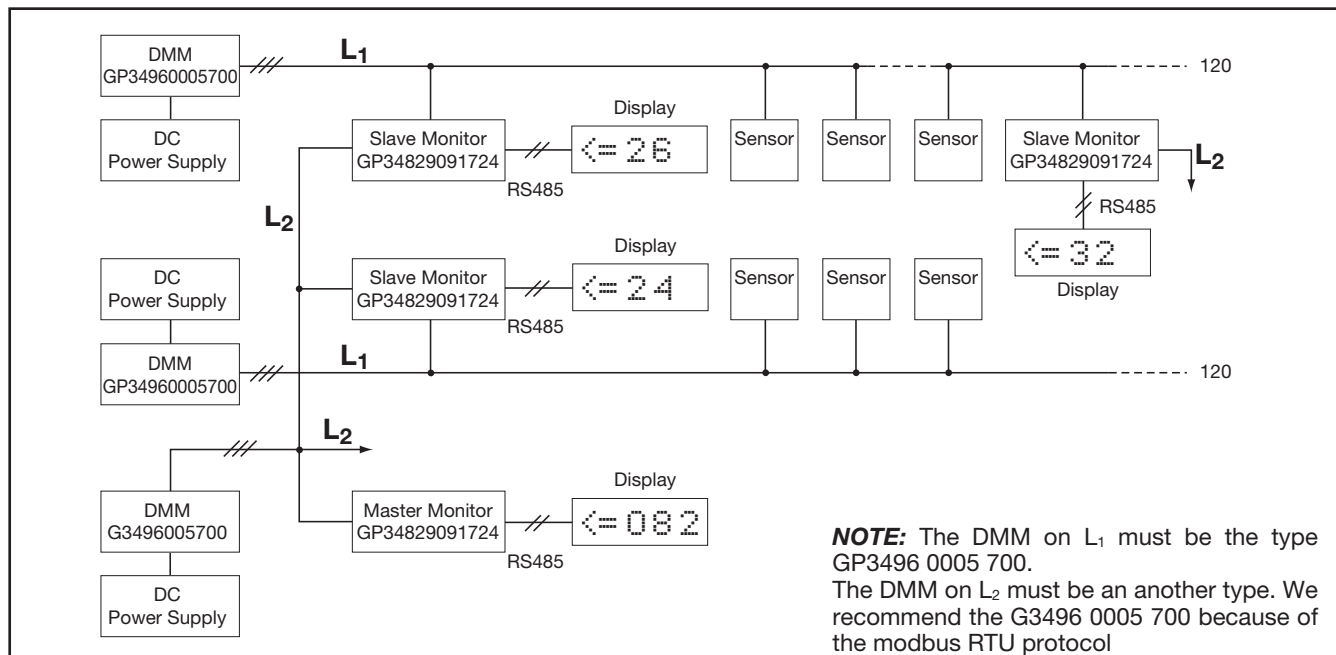

**NOTE:** The DMM on L<sub>1</sub> must be the type GP3496 0005 700. The DMM on L<sub>2</sub> must be an another type. We recommend the G3496 0005 700 because of the modbus RTU protocol

## Mode of Operation

The ceramic sensor emits an acoustic signal at a frequency of 40 kHz. The signal is reflected when it hits the floor and returned to the sensor. The reflected signal indicates whether the parking bay is available or occupied.

### Sensor addresses

• Status Dupline® address

The Dupline® bus address used by the sensor to transmit the status of the parking bay.

• Calibration Dupline® address

This address is used to trigger the sensor to perform a self calibration. Several sensors can be given the same calibration address, thereby making it possible to

calibrate multiple sensors at once by sending a single trigger signal on that address. The programming unit GP73800080 is used to send out the trigger signal.

### Modes

The sensor has two modes. Normal mode or Lane mode.

In **Normal mode**, the sensor is designed to be mounted in the ceiling directly above the car in the Carpark bay. The sensor detects the presence or no presence of a car and sends a signal on the Dupline® bus to the Carpark Monitor and Master module. Through the RS485 mod-bus interface of the Carpark

Master Module GP34960005 the PC/PLC can control the status of the two Dupline® bit-addresses (LED CH1, LED CH2) assigned to the sensor. Each of the four bit-combinations will result in a specific indication as shown above under "LED colour coding".

The sensors will not react to objects lower than 30 cm.

To avoid a weak signal, the sensor must be installed pointing directly at a hard surface, as for instance concrete. A soft or uneven surface will reduce the signal.

In **Lane mode**, the sensor is designed to be mounted in the ceiling above the lane.

The sensor is able to detect moving cars with a maximum speed of 20 km/hour. See fig. 2 on page 4.

When the sensor detects a moving car it sends a signal to the Carpark system that reduces the total amount of free places. The reduced amount is shown on the local display - but also on the display that shows the total amount of free places.

This is to prevent to many moving cars in a specific carpark area. The sensor does not show the actual status on the LEDs. The LEDs only work as feedback during calibration, startup and show the fail status.

The sensor is designed to work in an area which is:

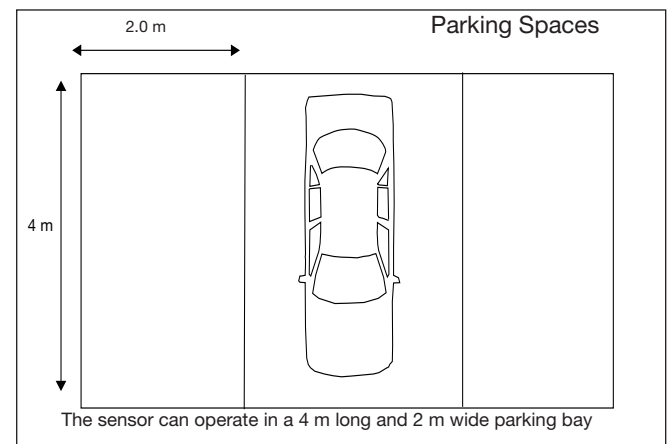
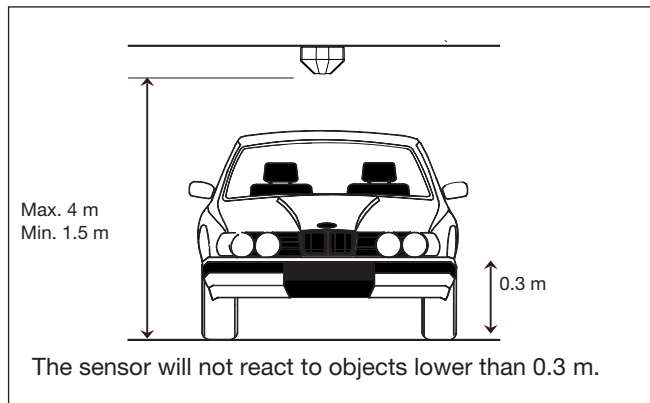

The sensor should be placed freely, e.g. in the following way:

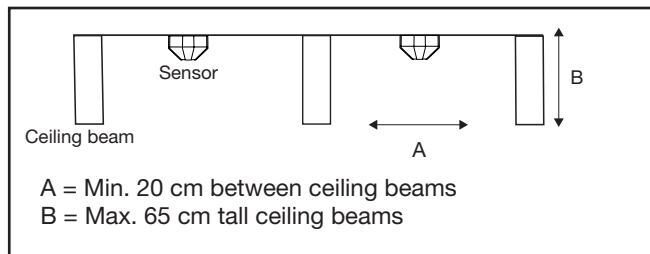

### Mounting the Sensor

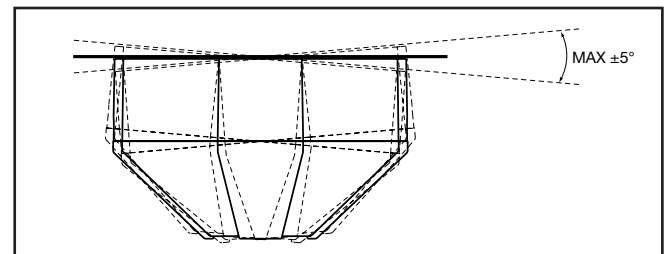

To receive the best signal, the sensor must be installed with an angle on the ceiling on maximum  $\pm 5^\circ$ .

## Calibration

The sensor is self-calibrating. It is important to perform the calibration when the parking bay is empty.

There are two ways of calibrating a sensor.

Manual calibration is a local calibration of the single sensor.

- Push the button on the outside of the sensor.

- The LED flashes green for 30 seconds with 1 Hz. (The electrician has time to get clear of the sensor before the calibration starts).
- The calibration starts when the LED flashes green for 6 seconds with 4 Hz.
- If the calibration is OK, the LED will respond with a constant green light.

### Error messages:

- If the calibration fails, the LED will respond with a constant flashing red light. If the LED flashes red, the sensor could be out of range or the sensor is not aligned correctly.
- Adjust the sensor into the sensing area and recalibrate the sensor.
- If Dupline® is not connected/defect the LED will flash red.

- If Dupline® is short circuit the LED will flash red.
- Sensor first time start up. The sensor LED will flash red because it needs calibration.

Automatic calibration with the Carpark Configurator GP7380 0080 is a global calibration of all connected sensors. The parking bay must be empty during the calibration process.

**Fig. 1 and Fig. 2**

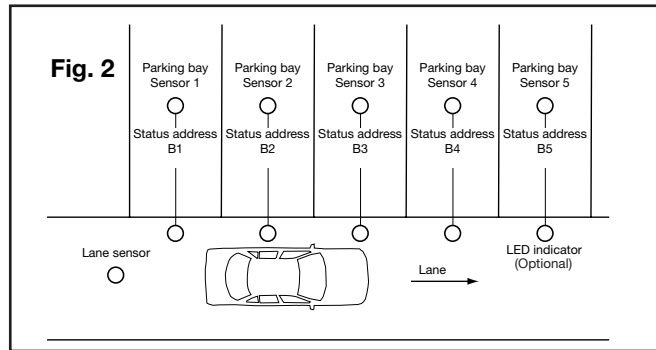
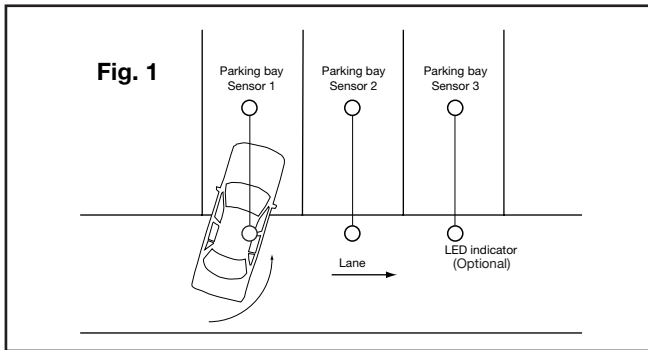

The sensors can be used as both parking bay (Normal mode) and lane sensors (Lane mode). See the manual on how to program the sensors.

## Environment

- Protection: IP 34
- Operating temperature: -40°C to 70°C
- Storage temperature: -40°C to 85°C
- Pollution Degree: 3 (IEC 60664)
- Dimensions: Ø118 x 76 mm
- Material: The case is made of polypropylene. The sensor lid is made of clear Polycarbonate.

## Dimensions

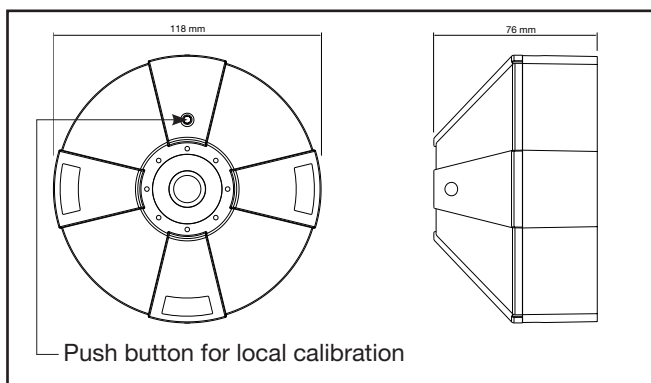

### Bottom part: mounted in ceiling

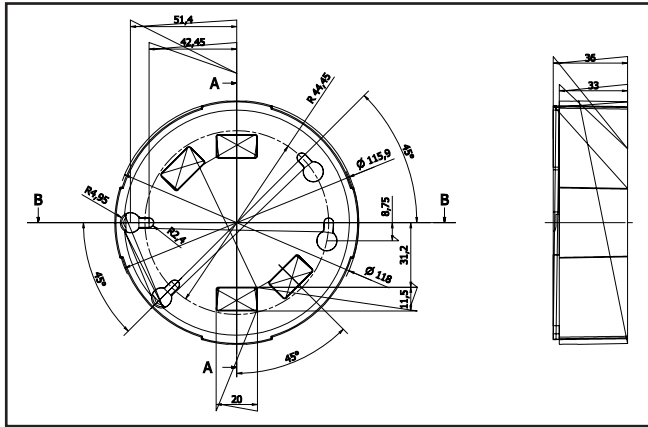

### Wiring Diagram

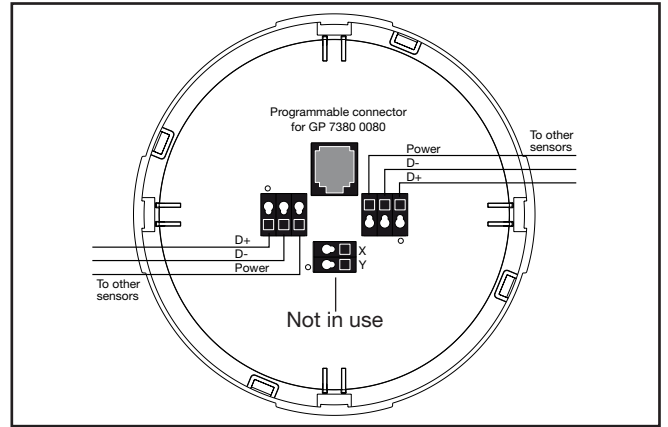

Note: The 2 x 3 pin connectors are internally connected on the PCB.

Note: X and Y is not in use for model number GP6220 330x-US.

**NOTE:** The wiring of the sensors must always be made with 1.5 mm<sup>2</sup> single core wire

### Connection diagram

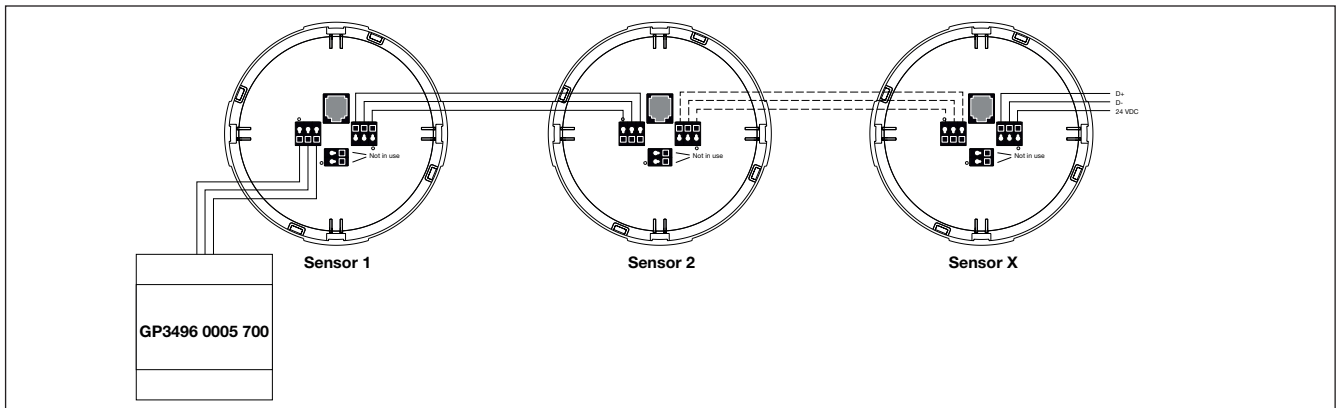

## X-ON Electronics

Largest Supplier of Electrical and Electronic Components

*Click to view similar products for [Proximity Sensors](#) category:*

*Click to view products by [Carlo Gavazzi](#) manufacturer:*

Other Similar products are found below :

[01.001.5653.1](#) [70.340.1028.0](#) [70.360.2428.0](#) [70.364.4828.0](#) [70.810.1053.0](#) [72.360.1628.0](#) [73.363.6428.0](#) [9221350022](#) [980659-1](#) [QT-12](#)  
[E2EX10D1NN](#) [E2E-X14MD1-G](#) [E2E-X2D1-G](#) [E2EX2ME2N](#) [E2E-X3D1-N](#) [10M](#) [E2E-X4MD1-G](#) [E2FMX1R5D12M](#) [E2K-F10MC1](#) [5M](#)  
[EI1204TBOSL-6](#) [EI5515NPAP](#) [BSA-08-25-08](#) [IC08ANC15PO-K](#) [IMM2582C](#) [25.161.3253.0](#) [25.332.0653.1](#) [25.352.0653.0](#) [25.352.0753.0](#)  
[25.523.3253.0](#) [9151710023](#) [922FS1.5C-A4P-Z774](#) [SC606ABV0S30](#) [SM952A126100LE](#) [A1220EUA-T](#) [F3S-A162-U](#) [CL18](#) [QT-08L](#)  
[34.110.0010.0](#) [TL-C2MF1-M3-E4](#) [IA08BLF15NOM5](#) [IA08BSF15NOM5](#) [IA12ASF04DOM1](#) [IMM32188C](#) [IS2](#) [IS31SE5000-UTLS2-TR](#)  
[34.110.0021.0](#) [34.110.0022.0](#) [CA150-120VACDC](#) [VM18VA3000Q](#) [XS508BSCBL2](#) [XS512BLNAM12](#)