

Wireless Entrapment Protection Device For Industrial Doors ESPE Type WSM / WSS ...

CARLO GAVAZZI

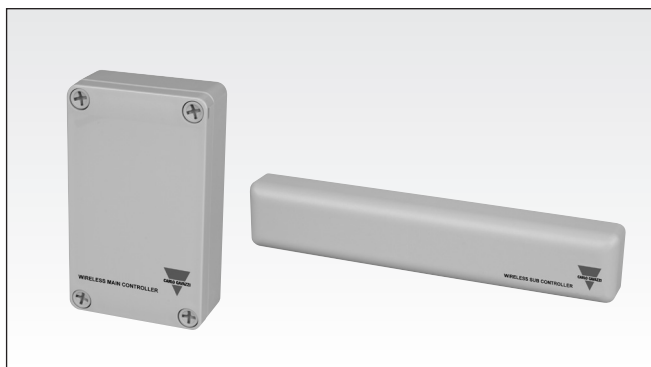

- Wireless Entrapment Protection Device for Industrial Doors
- Input for two ESPE (electro-sensitive protective equipment)
- Replaces cable between Door controller and ESPE
- Input for door-in-door sensor
- Output ESPE: 1 x SPST NC, 1 x SPST NO (8,2kΩ)
- Output low battery: 1 x SPST NC contact
- 2,4 GHz duplex communication
- Built-in antenna
- IP66 ratings



Product Description

Wireless Entrapment Protection Device (EPD) for Industrial Doors. The system is designed to replace the connection cable between the ESPE (electro-sensitive protective equipment) and the door controller. The sub controller has input for either N.C. ESPE, N.O. 8.2 kΩ ESPE or the Carlo Gavazzi low consumption photoelectric ESPE N.C. contact. The system is designed for high reliability

using 2.4 GHz duplex communication between the main controller and sub controller. The main controller can handle up to 4 sub modules i.e. one system can handle 8 ESPEs.

The sub controller is activated by a test signal from the main controller and stays active during the period of time set at the main controller up to 80 seconds.

Ordering Key

WSM 2 B A 2 D24

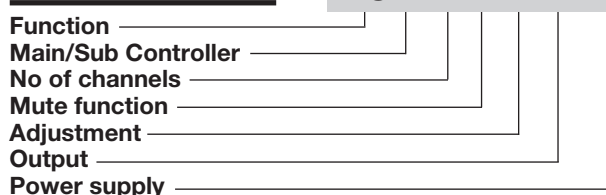

Type Selection

Housing W x H x D	Range Wireless	Type	Ordering no.
75 x 125 x 35 mm	10 m	Main Controller	WSM 2 B A 2 D24
45 x 214 x 22 mm	10 m	Sub Controller	WSS 2 B A 2 BAT

Housing W x H x D	Range S _n	Cable length	Type	Ordering no.
Ø11 x 24.5 mm	15 m	2 m	Emitter	PB 11 CNT 15 WE
Ø11 x 24.5 mm	15 m	12 m	Receiver	PB 11 CNT 15 WR

Specifications Main Controller (WSM)

Rated operational volt. (U_B)	12 to 24 VAC/DC (-10 +15%)	Indications Main Controller	Green LED
Ripple (U_{rpp})	≤ 10%	Power supply	2 x yellow LEDs
Supply current	< 50 mA	ESPE 1 or 2 active	Red LED
Communication Frequency	2.4 GHz Duplex	Low Battery	Toggle red & green LED
Number of channels	16 selectable via DIP switch	Channels not synchronized	
Sub Controller live time	10 – 80 sec. Selectable via DIP-switches	Test input (active high or active low)	Selectable via DIP switch
Relay ESPE NC ESPE NO 8.2 kΩ Low Battery	SPST SPST SPST 1 A / 30 VDC 0,5 A / 30 VAC >100.000 AC11 or DC11	Active high	12-24 V
Protection	Reverse polarity, transients	Active low	0 V
		Test impulse time	
		Minimum pulse width	> 100 mS
		Maximum pulse width	< 2 sec
		Operating frequency	25 Hz per sub controller
		Response time	
		OFF-ON (t _{ON})	≤ 120 ms
		ON-OFF (t _{OFF})	≤ 120 ms



Specifications Main Controller (WSM) (cont.)

Environmental		IC RSS210, RSS GEN, RSS-102 IC-ID: 7188C-WSM0001
Installation category	III (IEC 60664/60664A; 60947-1)	CE-marking EN12445, EN12453, EN12978 Radio Equipment and Telecommunications Terminal Equipment (R&TTE) Directive 1999/5/EC Low Voltage Directive 2006/95/EC Electromagnetic Compatibility Directive 2004/108/EC Machinery Directive 2006/42/EC, amended by Directive 98/79/EC For industrial doors only See EN13241-1
Pollution degree	3 (IEC 60664/60664A; 60947-1)	
Degree of protection	IP66	
Rated insulation voltage	50 VDC	
Temperature		
Operating Temperature	-25° to +55°C (-13° to +131°F)	
Storage Temperature	-40° to +70°C (-40° to +158°F)	
Size	75 x 35 x 125 mm	
Material		
Housing	Light Grey ABS	
Top	Light Grey ABS	
Weight	230 g	
Approvals	cULus UL508 FCC port 15 B,C FCC-ID: Y55WSM0001	

NOTE: Changes/modifications not approved by Carlo Gavazzi could void the user's authority to operate the equipment.

Specifications Sub Controller (WSS)

Rated operational volt. (U_B)	1 to 4 ER14505 3.6 VDC size AA Lithium batteries ≥ 2700 mAh	Environmental	
Supply current	< 40 mA	Installation category	III (IEC 60664/60664A; 60947-1)
Communication Frequency	2.4 GHz Duplex	Pollution degree	3 (IEC 60664/60664A; 60947-1)
Number of channels	16 selectable on DIP switch	Degree of protection	IP66
Sub Controller live time	10 – 80 Sec. Selectable on DIP-switches at the main controller	Rated insulation voltage	50 VDC
ESPE inputs		Temperature	
ESPE NC	Standard NC ESPE	Operating Temperature	-25° to +55°C (-13° to +131°F)
ESPE NO 8.2 kΩ	Standard NO, 8.2 kΩ	Storage Temperature	-40° to +70°C (-40° to +158°F)
Photoelectric ESPE	Carlo Gavazzi Low current ESPE PES for wireless applications	Size	22 x 45 x 214 mm
Door in door input	NC input from Limit Switch	Material	
Response time		Housing	Light Grey PC
OFF-ON (t _{ON})	≤ 120 mS	Bottom	Black PC
ON-OFF (t _{OFF})	≤ 120 mS	Weight	220 g
Wake time after sleep mode	≤ 400 mS	Approvals	cULus UL508 FCC port 15 B,C FCC-ID: Y55WSM0001 IC RSS210, RSS GEN, RSS-102 IC-ID: 7188C-WSM0001
Protection	Reverse polarity	CE-marking	EN12445, EN12453, EN12978 Radio Equipment and Telecommunications Terminal Equipment (R&TTE) Directive 1999/5/EC Low Voltage Directive 2006/95/EC Electromagnetic Compatibility Directive 2004/108/EC Machinery Directive 2006/42/EC, amended by Directive 98/79/EC For industrial doors only See EN13241-1
Indications Sub Controller			
ESPE 1	Yellow LED		
ESPE 2	Yellow LED shines in 20 sec. after a short activation on the pushbutton		
Test input	The submodule wakes up after the test input of the main controller		
Antenna	Built in		

NOTE: Changes/modifications not approved by Carlo Gavazzi could void the user's authority to operate the equipment.

Specifications Photoelectric Sensors ESPE (PB11)

Rated operational volt. (U_B)	From Sub Controller	Degree of protection	IP67
Rated operational dist. (S_n)	15 m	Housing size	Ø11 x 24.5 mm
Light source	LED 880 nm	Housing Material	PA6 Glass reinforced
Light Type	Infrared Modulated	UL-Approvals	UL508
Ambient light	>20,000 lux	CE-marking	EN12978

Operation Diagram

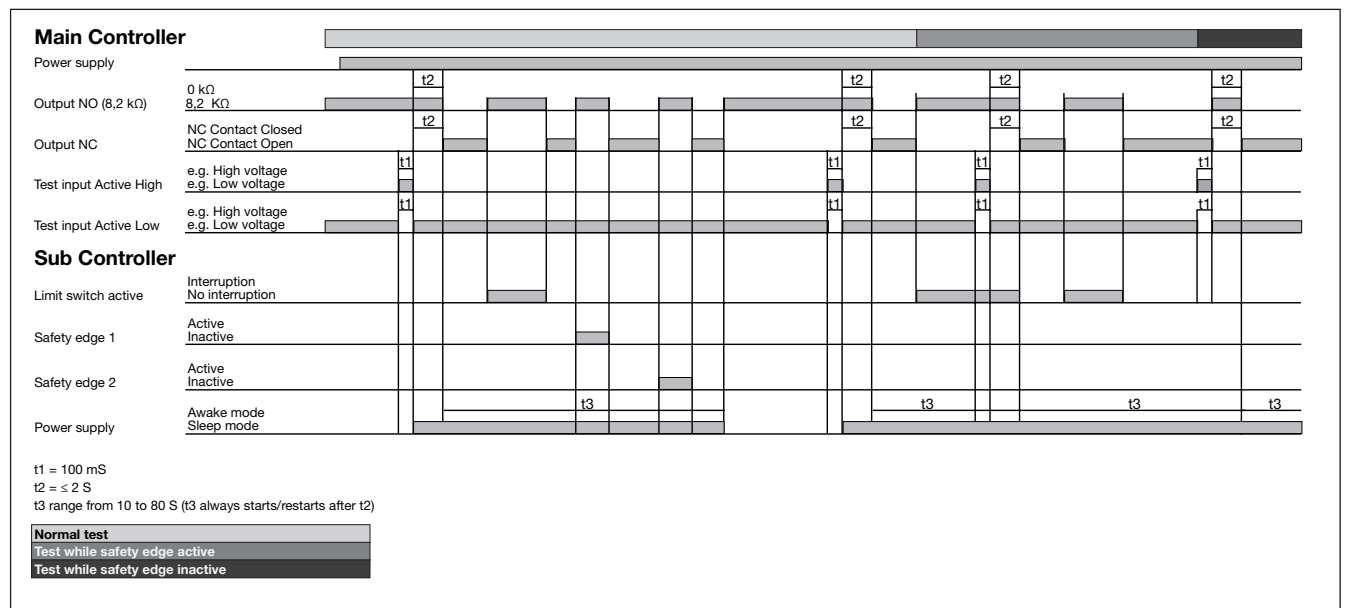

Wiring Diagrams

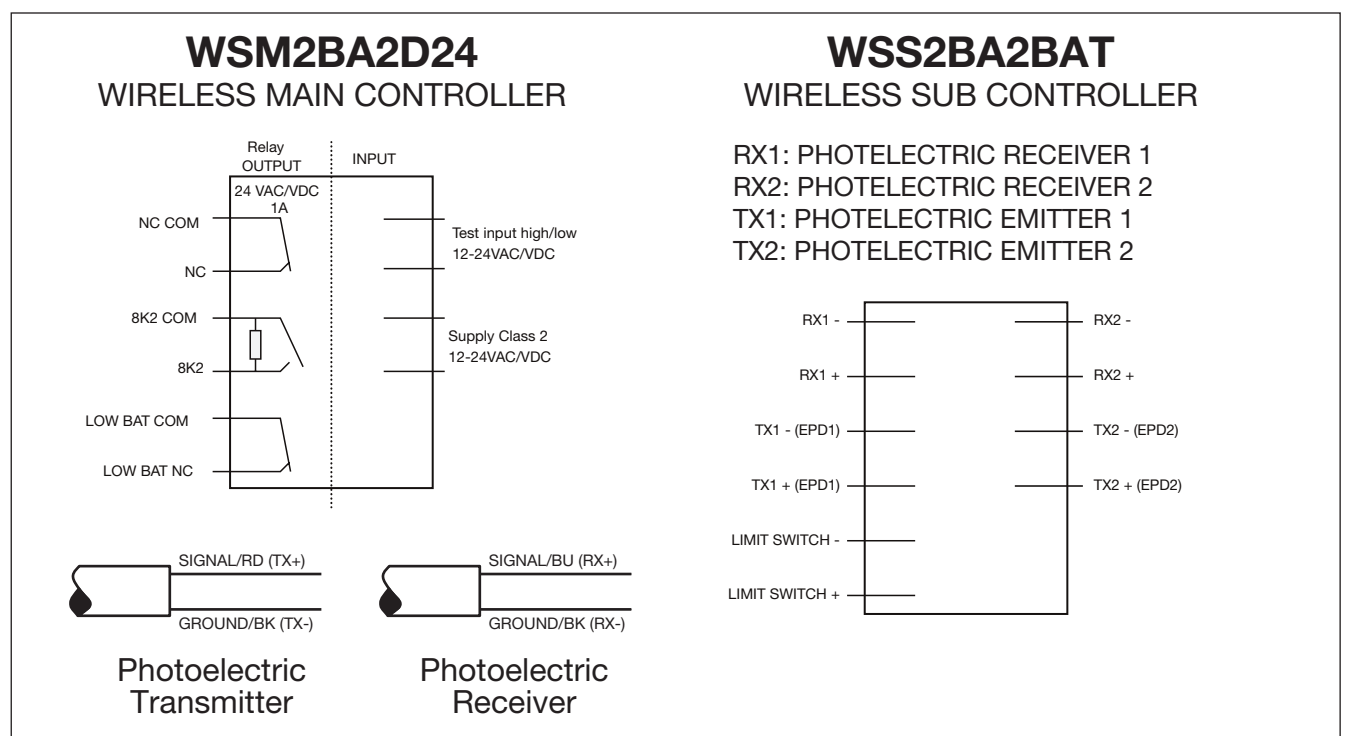



Detection Diagram

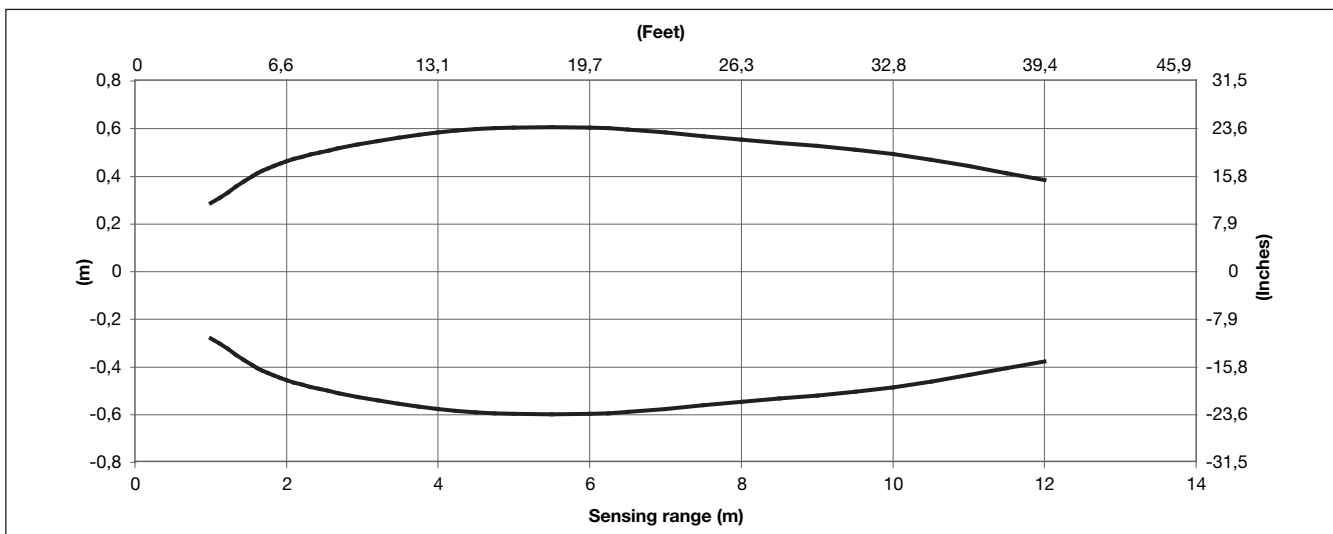

Excess Gain

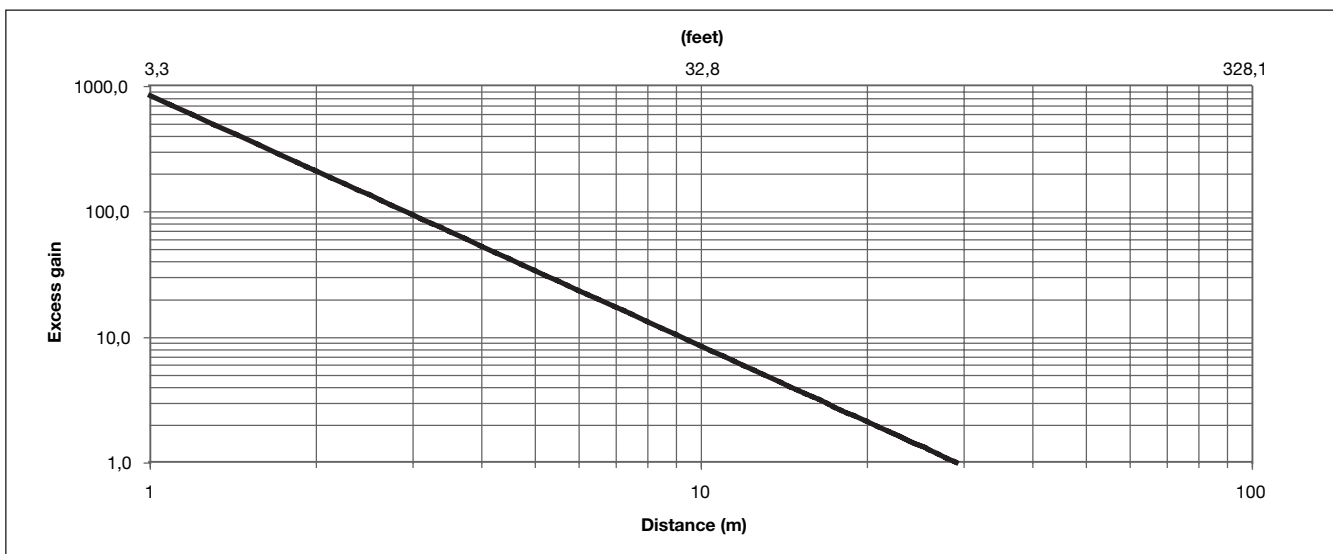

Battery Lifetime

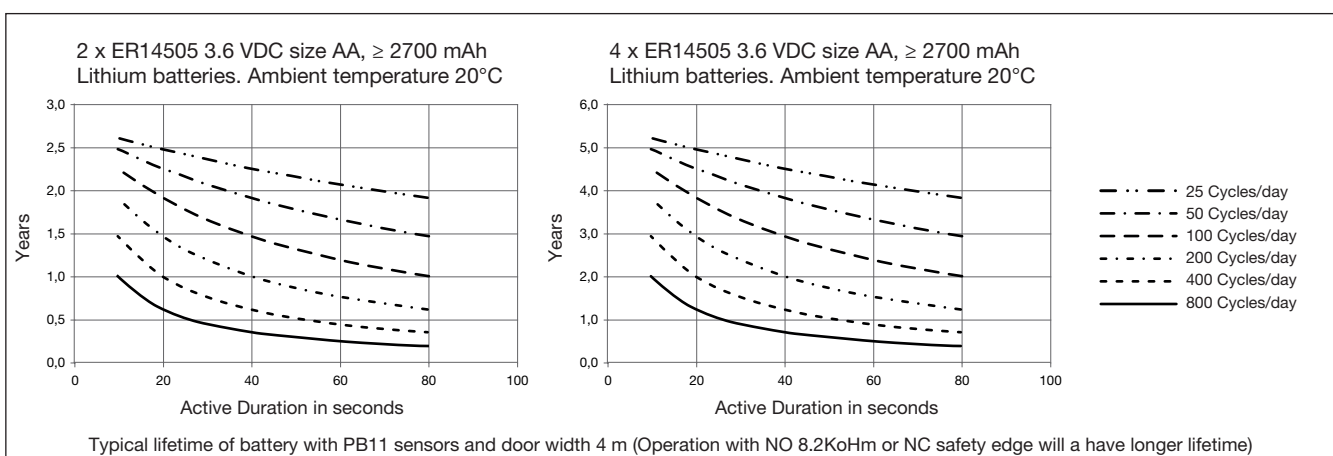

Dimensions

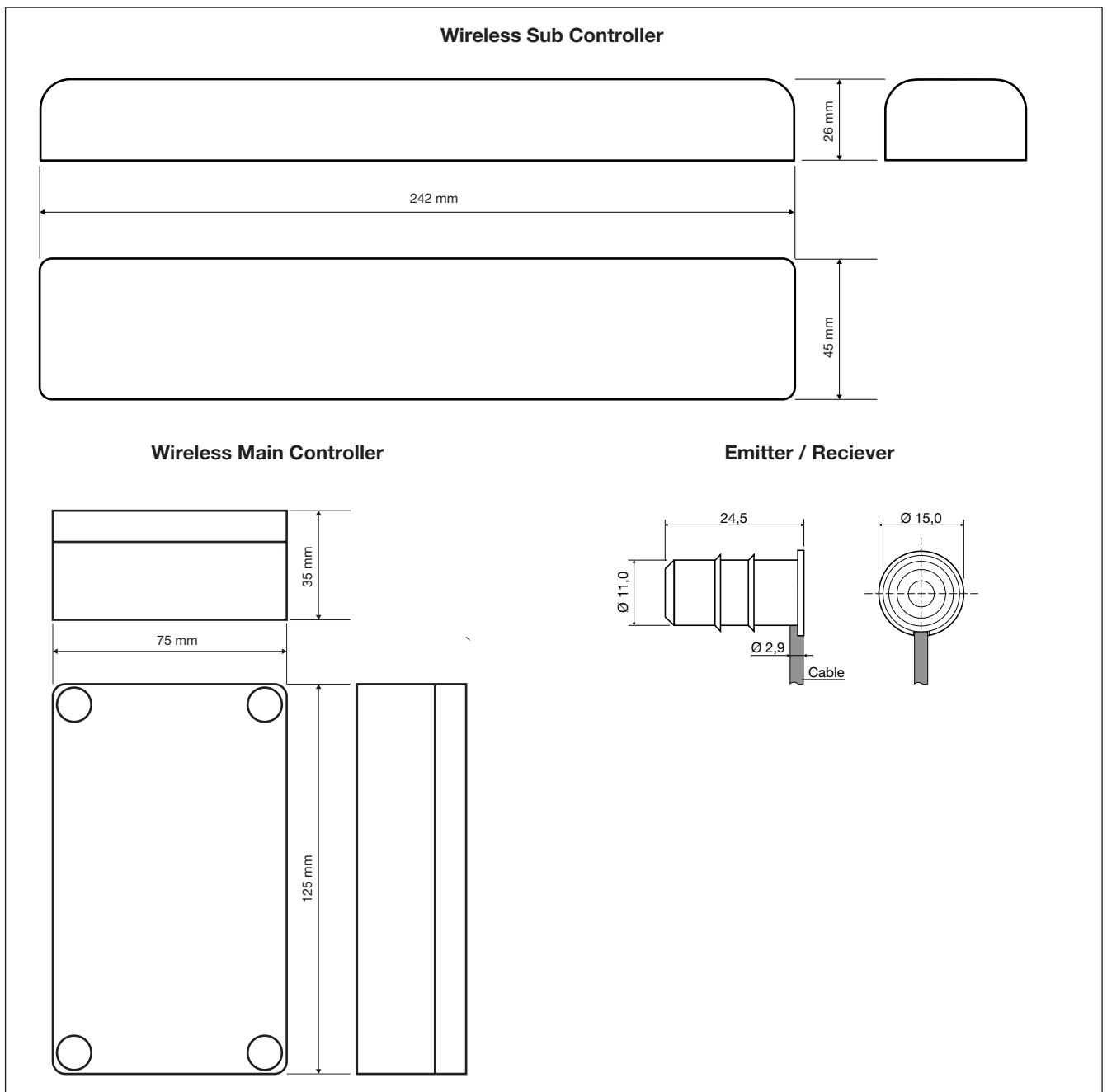

Delivery Contents Main Controller

- Wireless Main Controller: WSM2BA2D24
- Manual
- 4 x SCREW M4.5X45 MM BOSSARD BN615
- 4 x RAWLPLUG SX8 NYLON
- **Packaging:** Cardboard box

Delivery Contents Receiver

- Receiver: PB11CNT15WR
- **Packaging:** Plastic bag

Delivery Contents Sub Controller

- Wireless Sub Controller: WSS2BA2BAT
- Manual
- 2 x ER14505 3.6 VDC size AA \geq 2700 mAh Lithium batteries
- 4 x SCREW M4X10 MM BOSSARD BN1023
- **Packaging:** Cardboard box

Delivery Contents Emitter

- Emitter: PB11CNT15WE
- **Packaging:** Plastic bag

X-ON Electronics

Largest Supplier of Electrical and Electronic Components

Click to view similar products for [RF Modules](#) category:

Click to view products by [Carlo Gavazzi](#) manufacturer:

Other Similar products are found below :

[SIMSA868-PRO](#) [SIMSA915C-PRO](#) [SIMSA868C-PRO](#) [SIMSA433C-PRO](#) [SIMSA915-PRO](#) [AM-RX12A-433P](#) [SIMSA868C-N-PRO](#)
[SIMSA433C-N-PRO](#) [SIMSA915C-N-PRO](#) [2221706-1](#) [S2-107XB-Z2356-Z2352](#) [S2-10686-Z1L1D](#) [650201000G](#) [650200808G](#) [650201421G](#)
[AM-RRQ3-433P](#) [RC-SPIRIT2-433](#) [RC-SPIRIT2-868](#) [DL-RFM69HC-433M](#) [DL-RFM69HC-868M](#) [DL-RFM69HC-915M](#) [ECC961613EU](#)
[E01C-ML01SP2](#) [H330 A30-00](#) [RC-CC1310-868](#) [CTU-D2R](#) [CTU-D5N](#) [RFM110-433S1](#) [RFM119S-433S1](#) [RFM119W-433S1](#) [RFM219SW-](#)
[868S1](#) [RFM98PW-433S2](#) [CX-SMA174MMCX-219](#) [HM-T433](#) [HM-T868](#) [I2M-005](#) [650200738G](#) [650200819G](#) [650200847G](#) [650200901G](#)
[650200926G](#) [650201133G](#) [COTER-E4I](#) [COTER-ECI](#) [GSM-IPX/SMA](#) [MTD-EV3-N3-HDP](#) [RC2500HP-RC232](#) [RC-CC1310-434](#) [RCRX-868](#)
[RC-TX1-434](#)