

Timers

Asymmetrical Recycler

Types DCB01, PCB01

CARLO GAVAZZI



- Time range 0.1 s to 100h
- 4 knob selectable functions
 - Aa - Asymmetrical recycler ON first
 - Ab - Asymmetrical recycler OFF first
 - Sh - One shot time function
 - Dt - Two state delay on operate (2 relays versions only)
- Selection of time range by DIP switches
- Knob adjustable time setting Automatic start
- Output: 1 or 2 x SPDT relay
- For mounting on DIN rail in accordance with DIN/EN 50 022 or Plug-in
- 22.5 mm Euronorm or 36 mm plug-in module housing
- Combined AC and DC power supply voltage
- LED indication for relay status and power supply ON

Product Description

Combined function timer with asymmetrical recycler, one shot time and two state delay on operate functions. Individual selection of the time ranges from 0.1 s to 100 h.

For mounting on DIN-rail (DCB01) or Plug-in (PCB01).

Ordering key

DCB 01 C M24

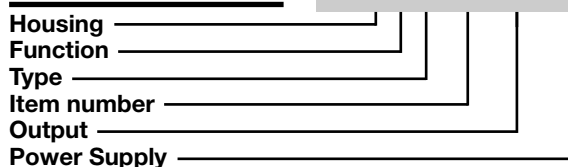

Type Selection

Mounting	Output	Housing	Supply: 24 VDC and 24 to 240 VAC	Supply: 24 to 240 VAC/DC
For DIN-rail	1 x SPDT 2 x SPDT	D-Housing	DCB 01 C M24	DCB 01 D M24
Plug-in	1 x SPDT 2 x SPDT	P-Housing	PCB 01 C M24	PCB 01 D M24

Time Specifications

Time ranges Selectable by DIP switches	0.1 to 1 s 1 to 10 s 6 to 60 s 60 to 600 s 0.1 to 1 h 1 to 10 h 10 to 100 h
Setting accuracy	≤ 5%
Repeatability	≤ 0.2%
Time variation Within rated power supply Within ambient temperature	(with respect to full scale value) ≤ 0.2% - whole range ≤ 500 ppm/°C
Reset Power supply interruption	≥ 200 ms

Output Specifications

Output	1 or 2 x SPDT relay
Rated insulation voltage	250 VAC (RMS)
Contact Ratings (AgSnO₂)	μ
Resistive Loads	AC 1 DC 12
Small inductive loads	AC 15 DC 13
AC 1	8 A @ 250 VAC
DC 12	5 A @ 24 VDC
AC 15	2.5 A @ 250 VAC
DC 13	2.5 A @ 24 VDC
Mechanical life	≥ 30 x 10 ⁶ operations
Electrical life	≥ 10 ⁵ operations (at 8 A, 250 V, cos φ = 1)
Operating frequency	< 7200 operations/h
Dielectric strength	
Dielectric voltage	2 kVAC (RMS)
Rated impulse withstand voltage	4 kV (1.2/50 μs)



Supply Specifications

Power Supply	Overvoltage cat. III (IEC 60664, IEC 60038)
Rated operational voltage trough terminals:	
(DCB01C) A1, A2: (PCB01C) 2, 10:	24 VDC ± 15 % and 24 to 240 VAC +10% -15% 45 to 65 Hz
(DCB01D) A1, A2: (PCB01D) 2, 10:	24 to 240 VAC/DC +10% -15%, 45 to 65 Hz
Voltage interruption	≤ 10 ms
Rated operational power	1.5 W

General Specifications

Power ON delay	≤ 100 ms
Power OFF delay	≤ 200 ms
Indication for	
Power supply ON	LED, green
Output relays ON	LED, yellow (flashing when timing)

General Specifications (cont.)

Environment	(EN 60529)
Degree of protection	IP 20
Pollution degree	3 (DCB01), 2 (PCB01) (IEC 60664)
Operating temperature	-20 to +60 °C, R:H: < 95%
Storage temperature	-30 to +80 °C, R:H: < 95%
Housing	
Dimensions	DCB01: 22.5 x 80 x 99.5 mm PCB01: 36 x 80 x 94 mm
Weight	Approx 100 g
Screw terminals	(DCB01)
Tightening torque	Max. 0.5 Nm according to IEC EN 60947
Approval	UL, CSA
CE Marking	Yes
EMC	Electromagnetic Compatibility
Immunity	According to EN 61000-6-2
Emission	According to EN 61000-6-3
Timer Specifications	According to EN 61812-1

Mode of Operation

Function Aa - Asymmetrical Recycler ON-time period first

The relay operates and the ON-time period (T1) begins as soon as the power supply is connected. After the ON-time period the relay releases for the OFF-time period (T2). This sequence continues until the power supply is interrupted for at least 200 ms.

Function Ab - Asymmetrical Recycler OFF-time period first

The OFF-time period (T1) begins as soon as the power supply is connected. After the OFF-time period the relay operates for the ON-time period (T2). This sequence continues until the power supply is interrupted for at least 200 ms.

Function Sh - One shot time function

The OFF-time period (T1) begins as soon as the power supply is connected. After the OFF-time period the relay operates for the ON-time period (T2). After the ON-time period the relay releases and does not operate until the power supply is interrupted for at least 200 ms and connected again.

Function Dt - Two state delay on operate (2 x SPDT versions)

The first time period (T1) begins as soon as the power supply is connected. At the end of the first time period the first relay operates and the second time period (T2) begins. At the end of the second time period the second relay operates. Both relays release when the power supply is disconnected.

Function/Range/Time Setting

Upper knob:

Setting of function:

Aa - asymmetrical recycler (ON first)

Ab - asymmetrical recycler (OFF first)

Sh - One shot time function

Dt - Two-state delay on operate (2 x SPDT versions)

Selection of time ranges

Adjust the T1 time range setting the DIP-switches 1 to 3 and the T2 time range setting the DIP-switches 4 to 6 as shown on the left.

To access the DIP-switches open the plastic cover using a screwdriver as shown below.

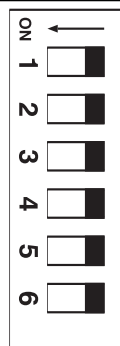
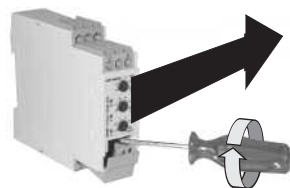

T1 time range

ON	ON	ON:	0.1 to 1 s
ON	ON	OFF:	1 to 10 s
ON	OFF	ON:	6 to 60 s
ON	OFF	OFF:	60 to 600 s
OFF	ON	ON:	0.1 to 1 h
OFF	ON	OFF:	1 to 10 h
OFF	OFF	ON:	10 to 100 h

T2 time range

ON	ON	ON:	0.1 to 1 s
ON	ON	OFF:	1 to 10 s
ON	OFF	ON:	6 to 60 s
ON	OFF	OFF:	60 to 600 s
OFF	ON	ON:	0.1 to 1 h
OFF	ON	OFF:	1 to 10 h
OFF	OFF	ON:	10 to 100 h

Centre knob:

Time T1 setting on relative scale: 1 to 10 with respect to the chosen range.

Lower knob:

Time T2 setting on relative scale: 1 to 10 with respect to the chosen range.

Operation Diagrams

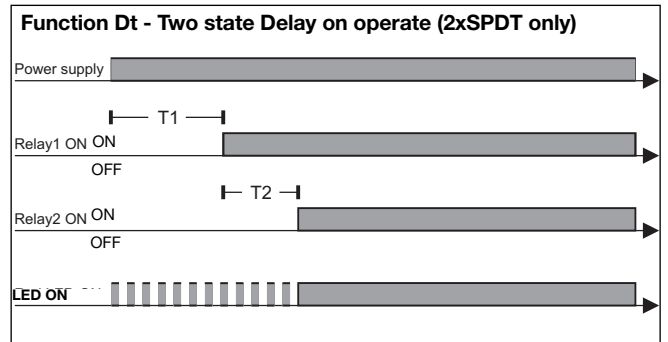
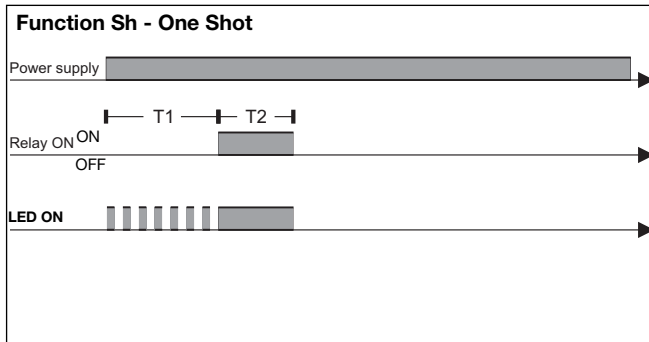
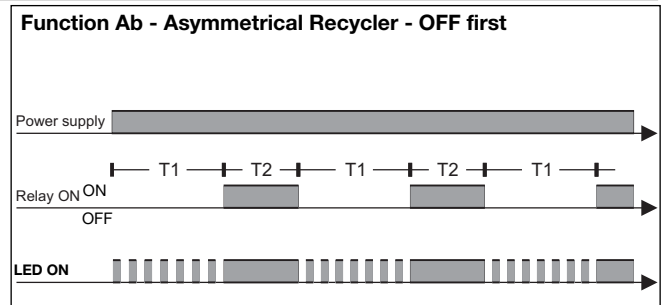
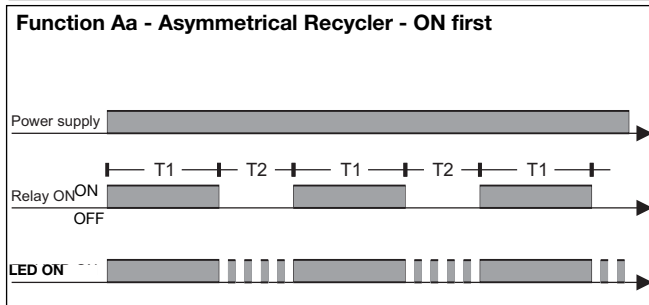

Wiring Diagrams

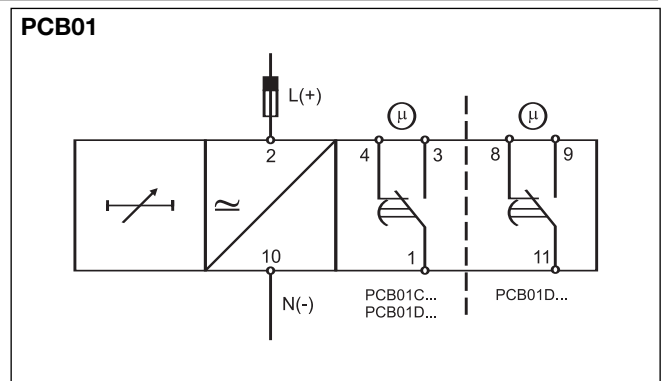
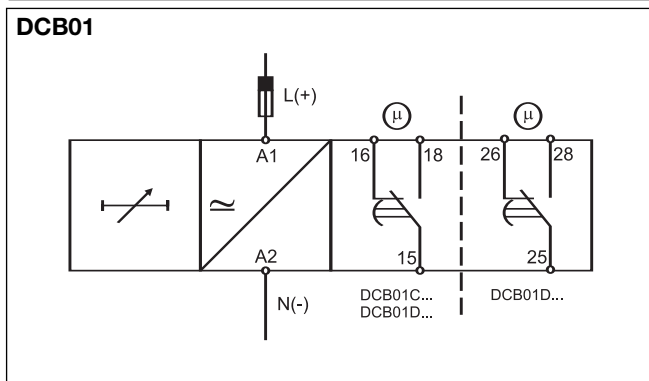

Dimensions

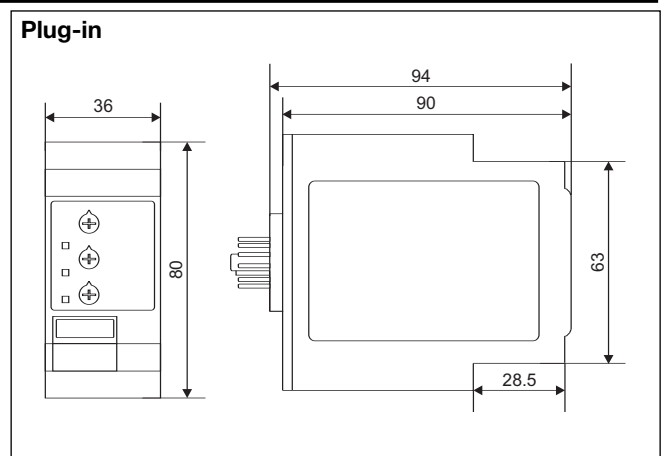
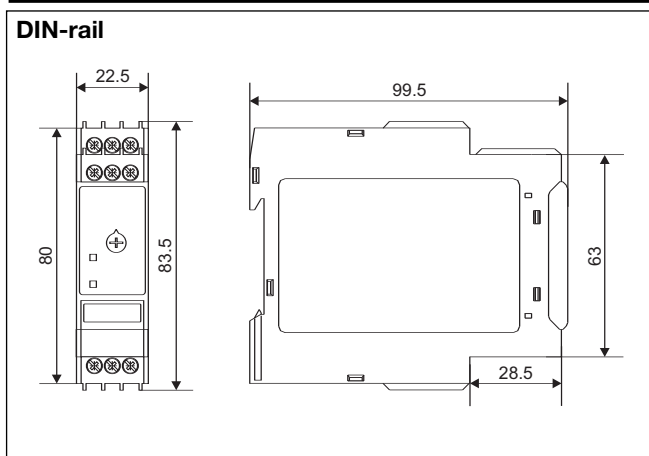

X-ON Electronics

Largest Supplier of Electrical and Electronic Components

Click to view similar products for [Time Delay & Timing Relays](#) category:

Click to view products by [Carlo Gavazzi](#) manufacturer:

Other Similar products are found below :

[5NO30](#) [614-11B-0A2](#) [614-11B-0A3](#) [614-11B-0A4](#) [614-11B-0A6](#) [614-11B-0A8](#) [614-11C-0A1](#) [614-11C-0A2](#) [614-11C-0A5](#) [614-11Q-0A3](#) [614-11Q-0A6](#) [614-11T-0A3](#) [614-11T-0A6](#) [614-11T-0A7](#) [614-12B-4A1](#) [614-12C-400](#) [614-12Q-400](#) [614-12T-600](#) [614-22T-4A1](#) [614-43B-400](#) [614-43C-100](#) [614-43F-200](#) [614-43Q-0A2](#) [614-43Q-100](#) [614-43Q-600](#) [614-43T-0A9](#) [614-43T-600](#) [614-43U-400](#) [614-43U-4A1](#) [614-43U-6A2](#) [615-21T-200](#) [655-11T-100](#) [655-11U-500](#) [655-12T-300](#) [655-22T-400](#) [655-22T-600](#) [CUA-41-30001](#) [CUA-41-30030](#) [CUA-41-70180](#) [CUA-41-71038](#) [CUA-42-30005](#) [CUA-42-30010](#) [CUA-42-30120](#) [CUA-42-70120](#) [CUA-99-72502](#) [CUC-41-30030](#) [CUF-42-30010](#) [CUH-41-31006](#) [7012AFX](#) [7012GD](#)