

Photoelectrics Diffuse-reflective Type PD30CND10...RT

CARLO GAVAZZI



- Miniature sensor range
- Range: 1 m
- Sensitivity adjustment by Teach-In programming
- Modulated, red light 660 nm
- Supply voltage: 10 to 30 VDC
- Output: 100 mA, NPN or PNP preset
- Make or break switching function programmable
- LED indication for output, stability and power ON
- Protection: reverse polarity, short circuit and transients
- Cable and plug versions
- Excellent EMC performance
- Remote teach features



Product Description

The PD30CND10 sensor family comes in a compact 10 x 30 x 20 mm reinforced PMMA/ABS housing. The sensors are useful in applications where high-accuracy detection as well as small size is required. Compact housing and high power LED for excellent performance-size ratio.

The Teach-In function for adjustment of the sensitivity makes the sensors highly flexible. The output type is preset (NPN or PNP), and the output switching function is NO or NC output. A remote teach feature allows the sensor to be set up from e.g. a PLC.

Ordering Key

PD30CND10PPM5RT

Type	_____
Housing style	_____
Housing size	_____
Housing material	_____
Housing length	_____
Detection principle	_____
Sensing distance	_____
Output type	_____
Output configuration	_____
Connection type	_____
Remote teach	_____

Type Selection

Housing W x H x D	Range S _n	Connection	Ordering no. NPN Make or break switching	Ordering no. PNP Make or break switching
10 x 30 x 20 mm	1 m	Cable	PD 30 CND 10 NPRT	PD 30 CND 10 PPRT
10 x 30 x 20 mm	1 m	Plug	PD 30 CND 10 NPM5RT	PD 30 CND 10 PPM5RT

Specifications EN 60947-5-2

Rated operating distance (S_n)	Up to 1 m, reference target Kodak test card R27, white, 90% reflective, 200 x 200 mm	Light source	GaAIAs, LED, 660 nm
Blind zone	20 mm	Light type	Red, modulated
Sensitivity	Adjustable by Teach-In	Sensing angle	± 2°
Temperature drift	≤ 0.1%/°C	Ambient light	10,000 lux
Hysteresis (H) (differential travel)	≤ 10%	Light spot	110 mm @ 1.5 m
Rated operational volt. (U_B)	10 to 30 VDC (ripple included)	Operating frequency	1000 Hz
Ripple (U_{rpp})	≤ 10%	Response time	
Output current Continuous (I _a) Short-time (I)	≤ 100 mA ≤ 100 mA (max. load capacity 100 nF)	OFF-ON (t _{ON})	≤ 0.5 ms
No load supply current (I_o)	≤ 30 mA @ 24 VDC	ON-OFF (t _{OFF})	≤ 0.5 ms
Minimum operational current (I_m)	0.5 mA	Power ON delay (t_v)	≤ 300 ms
OFF-state current (I_r)	≤ 100 μA	Output function	Preset Set up by button
Voltage drop (U_d)	≤ 2.4 VDC @ 100 mA	NPN and PNP NO/NC switching function	
Protection	Short-circuit, reverse polarity and transients	Remote teach function	
		Teach on	0 to 2.5 VDC (NPN) 5 to 30 VDC (PNP)
		Tamper proof	When activated more than 20 sec., the sensor goes into a tamper proof mode.
		Indication	
		Output ON	LED, yellow
		Signal stability ON and power ON	LED, green



Specifications (cont.) EN 60947-5-2

Environment		Rated insulation voltage	500 VAC (rms)
Installation category	III (IEC 60664/60664A; 60947-1)	Housing material	
Pollution degree	3 (IEC 60664/60664A; 60947-1)	Body material	ABS
Degree of protection	IP 67 (IEC 60529; 60947-1)	Front material	PMMA, red
Ambient temperature		Connection	
Operating	-25° to +55°C (-13° to +131°F)	Cable	PVC, black, 2 m 4 x 0.14 mm ² , Ø = 3.3 mm
Storage	-40° to +70°C (-40° to +158°F)	Plug	M8, 4-pin (CON. 54-series)
Vibration	10 to 55 Hz, 0.5 mm/7.5 g (IEC 60068-2-6)	Weight	With cable: 40 g With plug: 10 g
Shock	30 g / 11ms, 3 pos, 3 neg per axis (IEC 60068-2-6, 60068-2-32)	CE-marking	Yes
		Approvals	cULus (UL508)

Operation Diagram

tv = Power ON delay

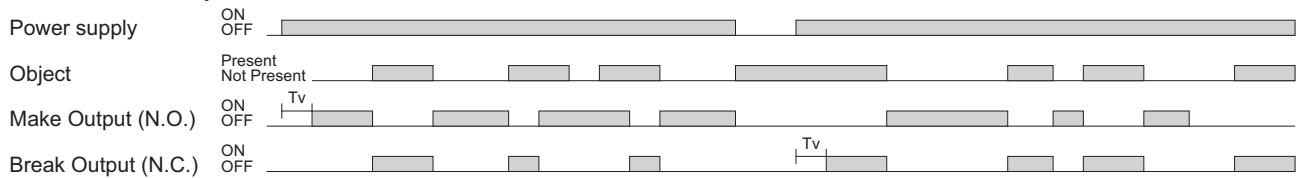

Wiring Diagrams

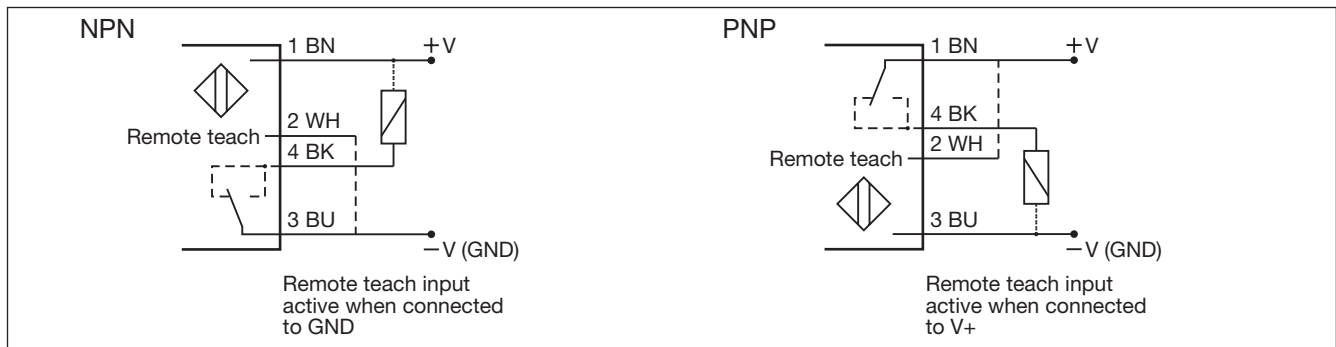

Detection Diagram

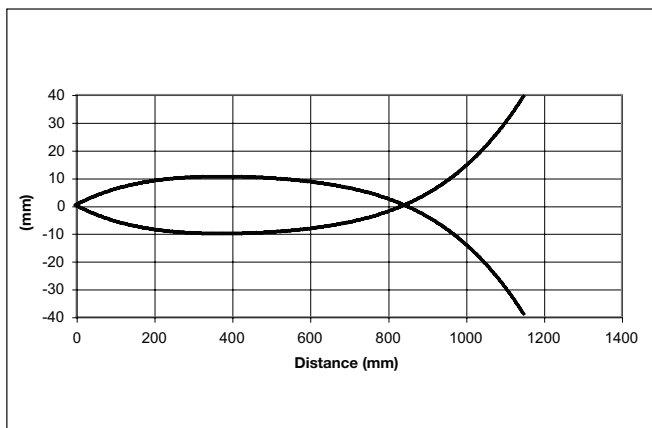

Excess Gain

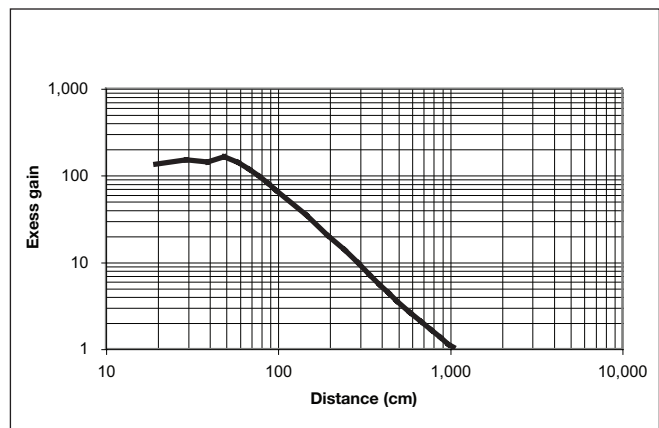

Signal Stability Indication

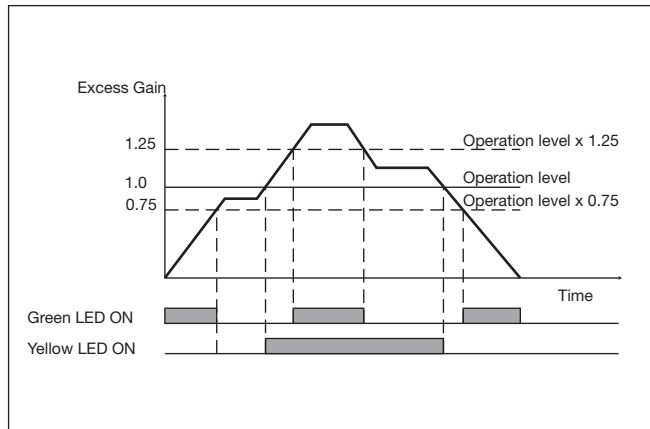

Accessories

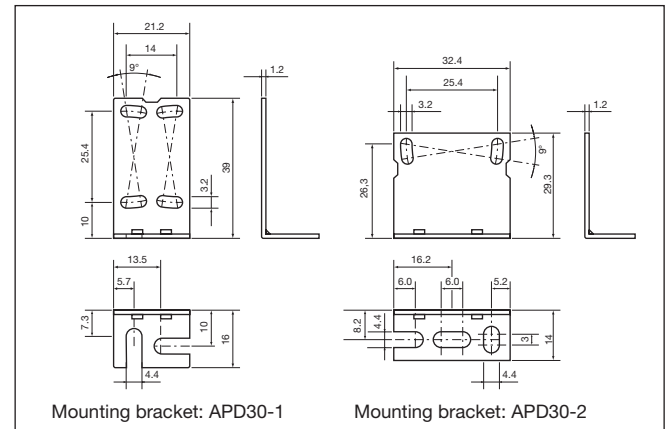

Dimensions

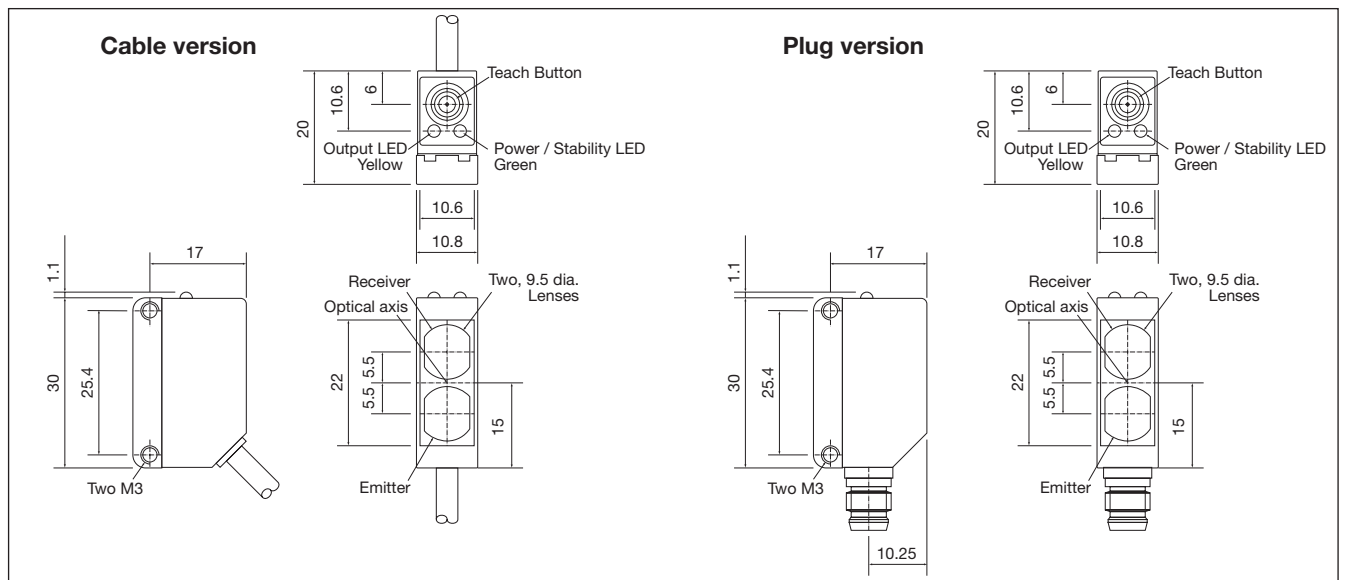

Installation Hints

<p>To avoid interference from inductive voltage / current peaks, separate the proximity switch cables from any other power cables. E.g. Engine, contactor or solenoid cables</p>	<p>Relief of the cable strain</p> <p>The cable should not be pulled</p>	<p>Protection of the sensing face</p> <p>A proximity switch should not serve as mechanical stop</p>	<p>Sensor mounted on a mobile carrier</p> <p>Any repetitive flexing of the cable should be avoided</p>
--	---	---	--

Delivery Contents

- Photoelectric switch: PD 30 CND 10 ...
- Installation instruction
- Mountingbracket APD30-MB1
- **Packaging:** Cardboard box

Accessories

- Mounting bracket APD30-MB2 to be purchased separately

Teach functions

Normal operation, optimized switching point

1. Line up the sensor at the background. Yellow LED is OFF and Green LED is ON.
2. Press the button for 3 seconds until both LEDs flashes simultaneously.
(The first switch point is stored)
3. Place the object in the detection zone.
4. Press the button once and the sensor is ready to operate (Green LED ON, Yellow LED ON)
(The second switch point is stored)

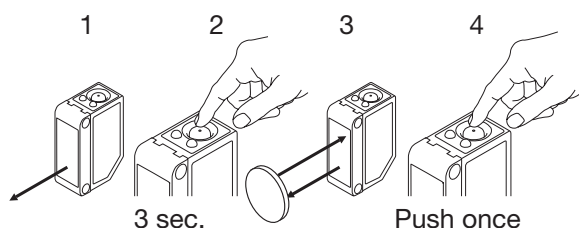

For dynamic set-up (running process)

1. Line up the sensor at the object. Green LED is ON, status on the yellow LED is not important.
2. Press the button for 3 second until both LEDs flashes simultaneously.
3. Press the button a second time for at least one second, both LED's flashes fast siultainiously and keep the button pressed for at least one process cycle, release the button and the sensor is ready to operate (The second switch point is stored)

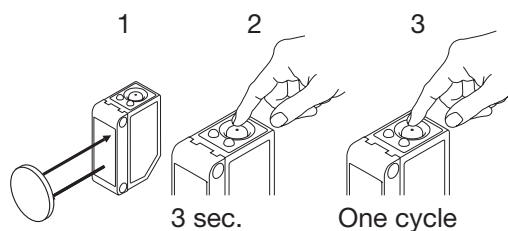

For maximum sensing distance (default setting)

1. Line up the sensor at the background. Yellow LED is OFF and Green LED is ON.
2. Press the button for 3 seconds until both LEDs flashes simultaneously.
(The first switch point is stored)
3. Press the button a second time and the sensor is ready to operate (Green LED ON, Yellow LED ON)
(The second switch point is stored)

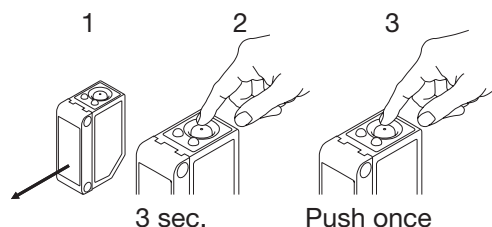

For make or break set-up (N.O. or N.C.)

1. Press the button for 10 seconds, until the green LEDs flashes.
2. While the green LED flashes, the output is inverted each time the button is pressed. Yellow LED indicates N.O. function selected.
If the button is not pressed within the next 10 seconds, the current output is stored.

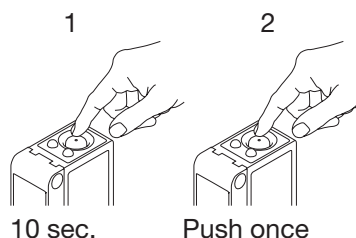

For minimum sensing distance

1. Line up the sensor at the object. Yellow LED is ON and Green LED is ON.
2. Press the button for 3 seconds until both LEDs flashes simultaneously.
(The first switch point is stored)
3. Press the button a second time and the sensor is ready to operate (Green LED ON, Yellow LED ON)
(The second switch point is stored)

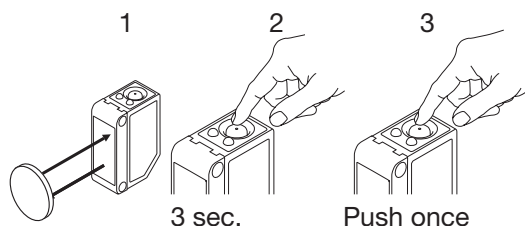

X-ON Electronics

Largest Supplier of Electrical and Electronic Components

Click to view similar products for [Photoelectric Sensors](#) category:

Click to view products by [Carlo Gavazzi](#) manufacturer:

Other Similar products are found below :

[022528-000](#) [10131270](#) [10131282](#) [10132112](#) [10132390](#) [10136503](#) [10137011](#) [10137012](#) [10137626](#) [10138309](#) [10138310](#) [10138745](#) [10139960](#)
[10139965](#) [10140588](#) [10140591](#) [10140593](#) [10140594](#) [10140708](#) [10140876](#) [10141536](#) [10141537](#) [10250TC2N](#) [1049062](#) [1161A-200](#)
[1202540067](#) [1265A-200](#) [1270A-300](#) [1273A-300](#) [13104A6513](#) [13104RQD07](#) [131520-000](#) [1450E-6514](#) [1451E-6547](#) [148582-000](#) [161](#)
[18.51.8.230.0040](#) [18.51.8.230.B300](#) [20848494](#) [298296-000](#) [301910-000](#) [395430-000](#) [3RG7120-3AA00](#) [3Z4S-LE SV-0614V](#) [3Z4S-LE SV-](#)
[0813V](#) [3Z4S-LE SV-10035V](#) [3Z4S-LE SV-1214H](#) [3Z4S-LE SV-1214V](#) [3Z4S-LE SV-3514H](#) [3Z4S-LE SV-3518V](#)