

Photoelectrics Diffuse-reflective Type PD30CND10...DU

CARLO GAVAZZI



- Miniature sensor range
- Range: 1 m
- Sensitivity adjustment by Teach-In programming
- Modulated, red light 660 nm
- Supply voltage: 10 to 30 VDC
- Output: 100 mA, NPN or PNP preset
- Make or break switching function programmable
- LED indication for output, stability and power ON
- Protection: reverse polarity, short circuit and transients
- Cable and plug versions
- Excellent EMC performance
- Dust alarm output



Product Description

The PD30CND10 sensor family comes in a compact 10 x 30 x 20 mm reinforced PMMA/ABS housing. The sensors are useful in applications where high accuracy detection as well as small size is required. Compact housing and high power LED for excellent performance-size ratio.

The Teach-In function for adjustment of the sensitivity makes the sensors highly flexible. The output type is preset (NPN or PNP), and the output switching function is one NO or NC output and one dust output NO or NC.

Ordering Key

PD30CND10PPM5DU

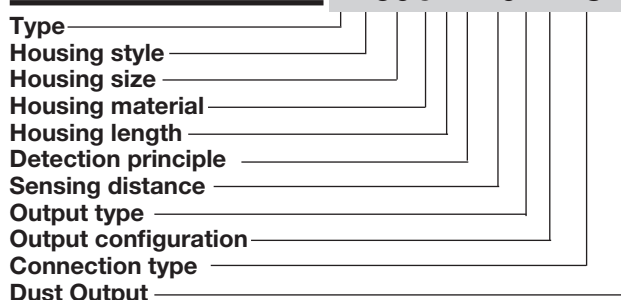

Type Selection

Housing W x H x D	Range S _n	Connection	Ordering no. NPN Make and break switching	Ordering no. PNP Make and break switching
10 x 30 x 20 mm	1 m	Cable	PD 30 CND 10 NPDU	PD 30 CND 10 PPDU
10 x 30 x 20 mm	1 m	Plug	PD 30 CND 10 NPM5DU	PD 30 CND 10 PPM5DU

Specifications EN 60947-5-2

Rated operating distance (S_n)	Up to 1 m, reference target Kodak test card R27, white, 90% reflective, 200 x 200 mm	Protection	Short-circuit, reverse polarity and transients
Blind zone	≤ 20 mm	Light source	GaAIAs, LED, 660 nm
Sensitivity	Adjustable by Teach-In	Light type	Red, modulated
Temperature drift	≤ 0.1%/°C	Sensing angle	± 2°
Hysteresis (H) (differential travel)	≤ 10%	Ambient light	10,000 lux
Rated operational volt. (U_B)	10 to 30 VDC (ripple included)	Light spot	110 mm @ 1.5 m
Ripple (U_{ripp})	≤ 10%	Operating frequency (f)	≤ 1000 Hz
Output current Continuous (I _a) Short-time (I)	≤ 100 mA ≤ 100 mA (max. load capacity 100 nF)	Response time OFF-ON (t _{ON}) ON-OFF (t _{OFF})	≤ 0.5 ms ≤ 0.5 ms
No load supply current (I_o)	≤ 30 mA @ 24 VDC	Power ON delay (t_v)	≤ 300 ms
Minimum operational current (I_m)	≤ 0.5 mA	Output function NPN and PNP Output configuration Programming options Output pin 4 black Output pin 2 white	Preset NO or NC NO or NC NO or NC (dust)
OFF-state current (I_r)	≤ 100 μA	Dust alarm output Delay on operate	20 ms
Voltage drop (U_d)	≤ 2.4 VDC @ 100 mA		



Specifications (cont.) EN 60947-5-2

Indication		Rated insulation voltage	≤ 500 VAC (rms)
Output ON	LED, yellow	Housing material	
Signal stability ON and Power ON	LED, green	Body	ABS
Environment		Frontglas	PMMA Red
Installation category	III (IEC 60664/60664A; 60947-1)	Connection	
Pollution degree	3 (IEC 60664/60664A; 60947-1)	Cable	PVC, black, 2 m 4 x 0.14 mm ² , Ø = 3.3 mm M8, 4-pin (CON. 54-series)
Degree of protection	IP 67 (IEC 60529; 60947-1)	Plug	
Ambient temperature		Weight	
Operating	-25° to +60°C (-13° to +140°F)	Cable version	≤ 40 g
Storage	-40° to +70°C (-40° to +158°F)	Plug version	≤ 10 g
Vibration	10 to 55 Hz, 0.5 mm/7.5 g (IEC 60068-2-6)	CE-marking	Yes
Shock	30 g / 11ms, 3 pos, 3 neg per axis (IEC 60068-2-6, 60068-2-32)	Approvals	cULus (UL508 + CSA)

Operation Diagram

Tv = Power ON delay

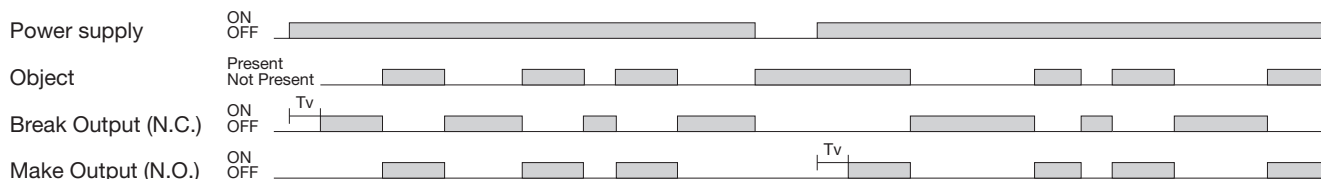

Wiring Diagrams

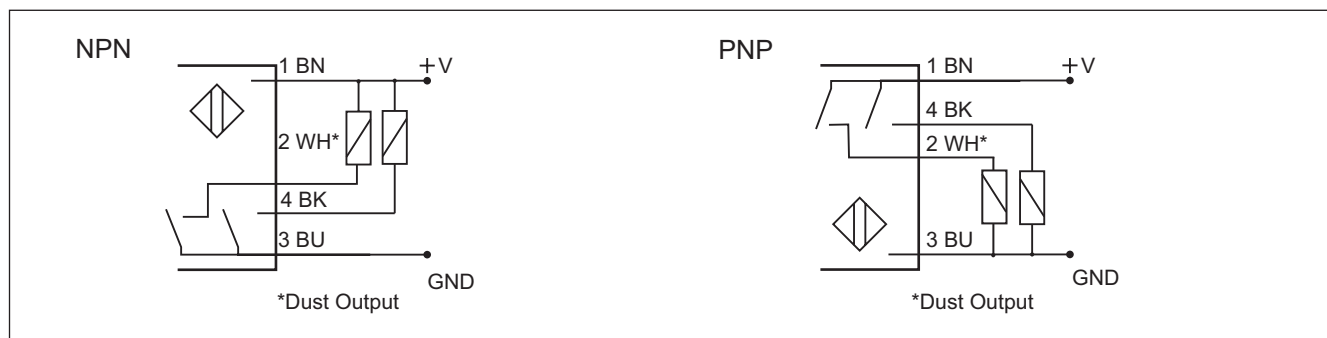

Detection Diagram

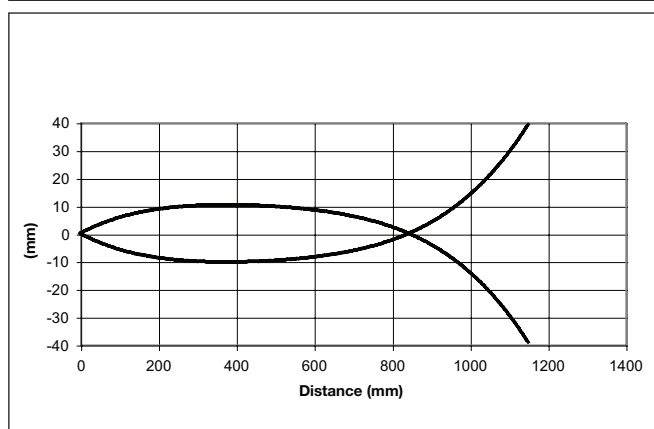

Excess Gain

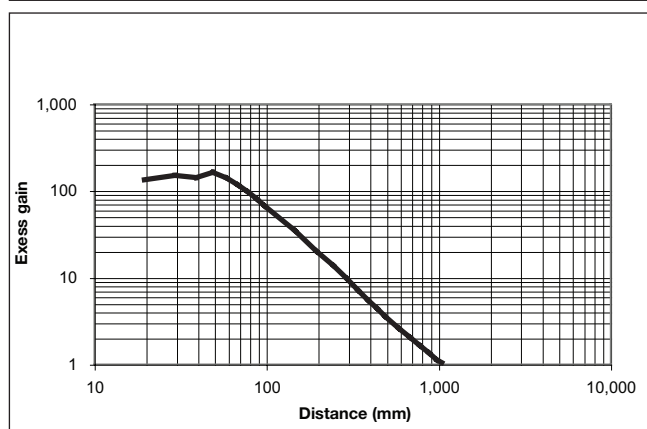

Signal Stability Indication

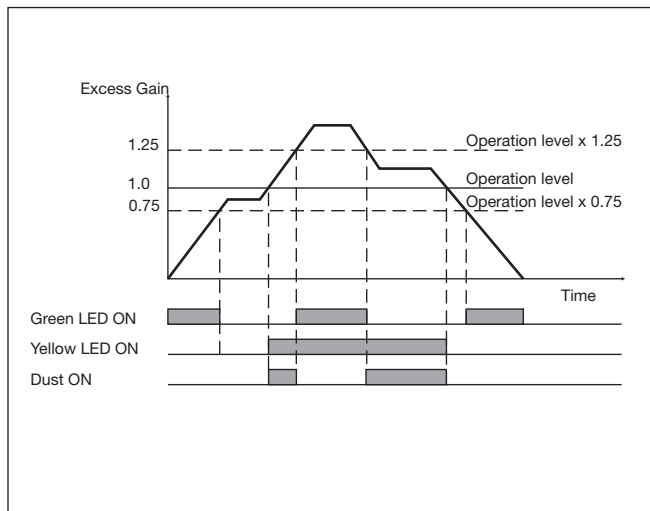

Accessories

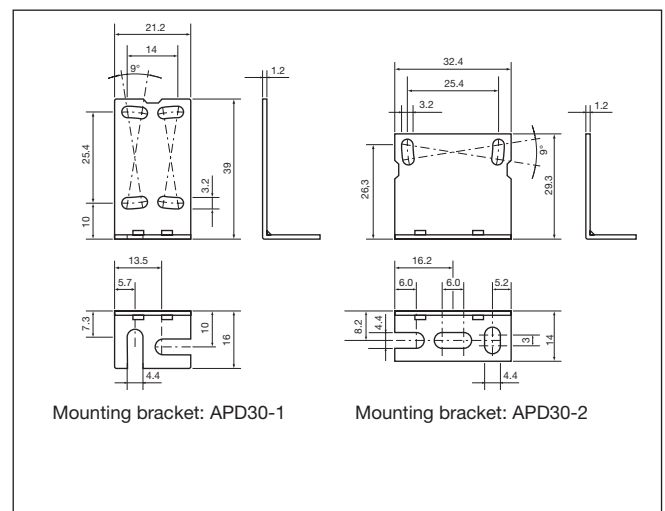

Dimensions

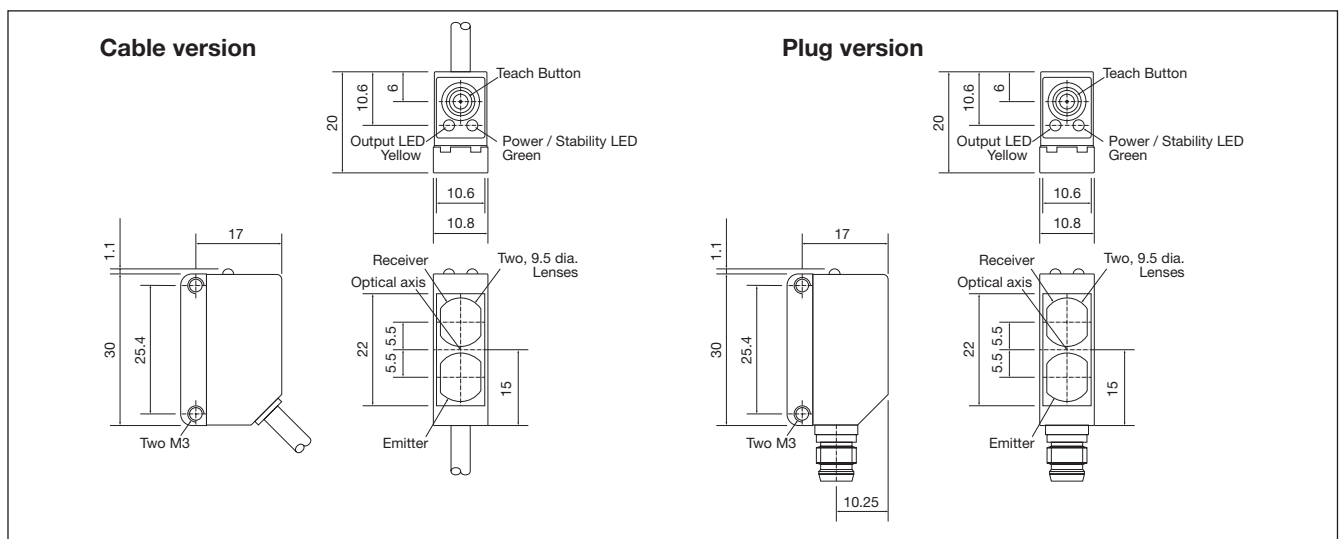

Installation Hints

<p>To avoid interference from inductive voltage / current peaks, separate the proximity switch cables from any other power cables. E.g. Engine, contactor or solenoid cables</p> <p>Incorrect: Cables bundled together. Correct: Cables separated by > 100 mm.</p>	<p>Relief of the cable strain</p> <p>Incorrect: Cable pulled. Correct: Cable looped.</p> <p>The cable should not be pulled</p>	<p>Protection of the sensing face</p> <p>Incorrect: Cable bent against sensing face. Correct: Cable bent away.</p> <p>A proximity switch should not serve as mechanical stop</p>	<p>Sensor mounted on a mobile carrier</p> <p>Correct: Sensor mounted on a carrier. Incorrect: Repeated flexing of the cable.</p> <p>Any repetitive flexing of the cable should be avoided</p>
---	--	--	---

Delivery Contents

- Photoelectric switch: PD 30 CND 10 ...
- Installation instruction
- Mounting bracket APD30-MB1
- **Packaging:** Cardboard box

Accessories

- Mounting bracket APD30-MB1 or APD30-MB2 to be purchased separately.

Teach functions

Normal operation, optimized switching point.

1. Line up the sensor at the background. Yellow LED is OFF and Green LED is ON.
2. Press the button for 3 seconds until both LEDs flashes simultaneously.
(The first switch point is stored)
3. Place the object in the detection zone.
4. Press the button once and the sensor is ready to operate (Green LED ON, Yellow LED ON)
(The second switch point is stored)

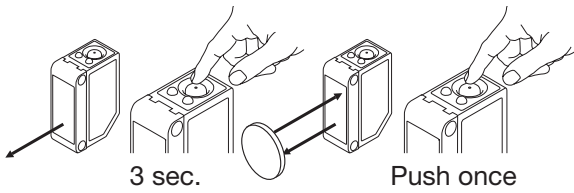

For dynamic set-up (running process)

1. Line up the sensor at the object. Green LED is ON, status on the yellow LED is not important.
2. Press the button for 3 second until both LEDs flashes simultaneously.
3. Press the button a second time for at least one second, both LED's flashes fast simultaneously and keep the button pressed for at least one process cycle, release the button and the sensor is ready to operate (The second switch point is stored)

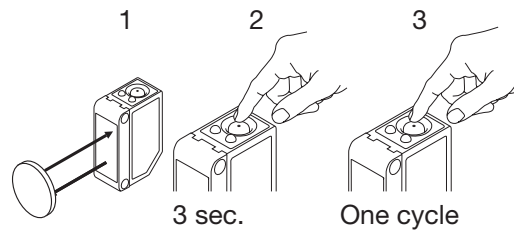

For maximum sensing distance (default setting)

1. Line up the sensor at the background. Yellow LED is OFF and Green LED is ON.
2. Press the button for 3 seconds until both LEDs flashes simultaneously.
(The first switch point is stored)
3. Press the button a second time and the sensor is ready to operate (Green LED ON, Yellow LED ON)
(The second switch point is stored)

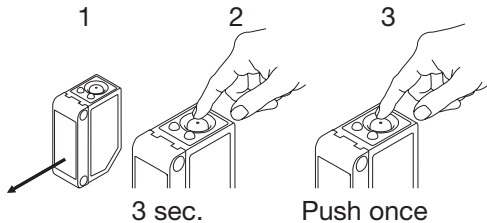

For make or break set-up (N.O. or N.C.)

1. Press the button for 10 seconds, until the green LEDs flashes.
2. While the green LED flashes, the output is inverted each time the button is pressed. Yellow LED indicates N.O. function selected.
If the button is not pressed within the next 10 seconds, the current output is stored.

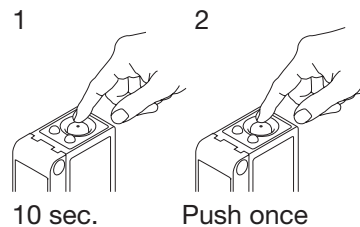

For minimum detection overhead.

1. Line up the sensor at the object. Yellow LED is ON and Green LED is ON.
2. Press the button for 3 seconds until both LEDs flashes simultaneously.
(The first switch point is stored)
3. Press the button a second time and the sensor is ready to operate (Green LED ON, Yellow LED ON)
(The second switch point is stored)

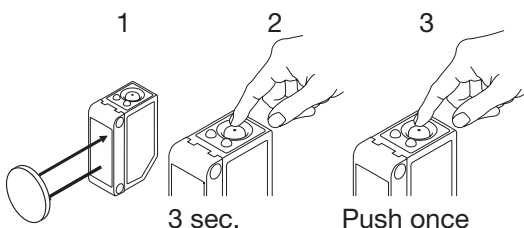

For dust output (N.O. or N.C.)

1. Press the button for 15 seconds, until the yellow LEDs flashes.
2. While the yellow LED flashes, the dust output is inverted each time the button is pressed. Green LED indicates N.O. function selected.
If the button is not pressed within the next 10 seconds, the current output is stored.

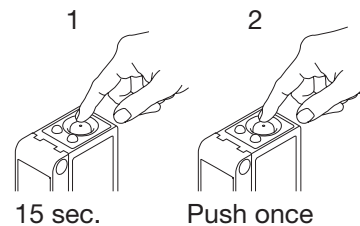

X-ON Electronics

Largest Supplier of Electrical and Electronic Components

Click to view similar products for [Photoelectric Sensors](#) category:

Click to view products by [Carlo Gavazzi](#) manufacturer:

Other Similar products are found below :

[7442AD2X5FRX](#) [EX-19B-LP](#) [7443AR0X5FRX](#) [7452AD4D4NNX](#) [F3WD052C5M](#) [7655AR-04-F-1-2-RX](#) [7694ADE04DS2X](#) [FE7C-FRC6S-M](#) [PM-R24-R](#) [Q45VR2FPQ](#) [13104RQD07](#) [E3JUXM4MN](#) [E3L2DC4](#) [E3S3LE21](#) [E3SCT11M1J03M](#) [E3SDS20E21](#) [E3VDS70C43S](#)
[E3XNM16](#) [BR23P](#) [HOA6563-001](#) [OJ-3307-30N8](#) [OS-311A-30](#) [P32013](#) [P34036](#) [P43004](#) [P56001](#) [P60001](#) [PB10CNT15PO](#) [S14132](#) [935286-000](#) [S52101](#) [S56258](#) [SH-21E](#) [FD-SN500](#) [FE7B-FDRB6-M](#) [SU-79](#) [T36342](#) [T40300](#) [T60001](#) [PD60CNX20BP](#) [FX2-A3R](#) [FX-302-HY](#) [FZS](#)
[PM-T64W](#) [PX-22](#) [PZ2-51P](#) [CX-491-P-J](#) [CYNUTX10](#) [UZH802](#) [UZH803](#)