

# Solid State Relays

## Low Voltage AC/DC Control: 5 to 24 V

### Types RM 23M, RM 40M, RM 48M, RM 60M



- Zero switching AC Solid State Relay
- Low voltage AC/DC control: 5 to 24 V
- Direct copper bonding (DCB) technology
- LED indication
- Built-in varistor
- Clip-on IP 20 protection cover
- Self-lifting terminals
- Housing free of moulding mass
- Operational ratings: Up to 100AACrms and 600VACrms
- Opto-isolation: > 4000VACrms

## Product Description

The industrial, 1-phase relay with antiparallel thyristor output is the most widely used SSR due to its multiple application possibilities. This relay has been designed to interface low voltage AC or DC control systems with high voltage resistive, inductive and capacitive loads. The zero switching relay switches ON when the sinusoidal curve

crosses zero and switches OFF when the current crosses zero. The built-in varistor secures transient protection for the heavy industrial applications, and the LED indicates the status of the control input. The clip-on cover is securing touch safety to IP 20. Protected output terminals can take cables up to 16 mm<sup>2</sup>.

## Ordering Key

**RM 1 A 23 M 25**

- Solid State Relay
- Number of poles
- Switching mode
- Rated operational voltage
- Control voltage
- Rated operational current

## Type Selection

Switching mode	Rated operational voltage	Control voltage	Rated operational current
A: Zero Switching	23: 230VACrms 40: 400VACrms 48: 480VACrms 60: 600VACrms	M: 5 to 24VDC/AC	25: 25AACrms 50: 50AACrms 75: 75AACrms 100: 100AACrms

## Selection Guide

Rated operational voltage	Blocking voltage	Control voltage	Rated operational current			
			25 AACrms	50 AACrms	75 AACrms	100 AACrms
230VACrms	650V <sub>p</sub>	5 to 24VDC/AC	RM1A23M25	RM1A23M50	RM1A23M75	RM1A23M100
400VACrms	850V <sub>p</sub>	5 to 24VDC/AC	RM1A40M25	RM1A40M50	RM1A40M75	RM1A40M100
480VACrms	1200V <sub>p</sub>	5 to 24VDC/AC	RM1A48M25	RM1A48M50	RM1A48M75	RM1A48M100
600VACrms	1400V <sub>p</sub>	5 to 24VDC/AC	RM1A60M25	RM1A60M50	RM1A60M75	RM1A60M100

## General Specifications

	RM1A23M	RM1A40M	RM1A48M	RM1A60M
Operational voltage range	24 to 265VACrms	42 to 440VACrms	42 to 530VACrms	42 to 660VACrms
Blocking voltage	≥ 650V <sub>p</sub>	≥ 850V <sub>p</sub>	≥ 1200V <sub>p</sub>	≥ 1400V <sub>p</sub>
Zero voltage turn-on	≤ 15V	≤ 15V	≤ 15V	≤ 15V
Operational frequency range	45 to 65Hz	45 to 65Hz	45 to 65Hz	45 to 65Hz
Power factor	> 0.5 @ 230VACrms	> 0.5 @ 400VACrms	> 0.5 @ 480VACrms	> 0.5 @ 600VACrms
Approvals	UL, CSA, EAC	UL, CSA, EAC	UL, CSA, EAC	UL, CSA, EAC
CE-marking	Yes	Yes	Yes	Yes *

\* Heatsink must be connected to ground.



## Input Specifications

<b>Absolute max. input voltage</b>	37VDC 28VAC
<b>Pick-up voltage</b>	4.0VDC 4.0VAC
<b>Drop out voltage</b>	2.0VDC 2.0VAC
<b>Input current</b> @ 5 VAC @ 24 VAC @ 5 VDC @ 24 VDC	≤ 10mA ≤ 18mA ≤ 9mA ≤ 12mA
<b>Response time pick-up</b>	≤ 1 cycle
<b>Response time drop-out</b>	≤ 2.5 cycles

## Isolation

<b>Rated isolation voltage</b> Input to output	≥ 4000VACrms
<b>Rated isolation voltage</b> Output to case	≥ 4000VACrms

## Housing Specifications

<b>Weight</b> 25 A, 50 A 75 A, 100 A	Approx. 60g Approx. 100g
<b>Housing material</b>	Noryl GFN 1, black
<b>Baseplate</b> 25 A, 50 A 75 A, 100 A	Aluminium Copper, nickel-plated
<b>Potting compound</b>	None
<b>Relay</b> Mounting screws Mounting torque	M5 1.5-2.0Nm
<b>Control terminal</b> Mounting screws Mounting torque	M3 x 9 0.5Nm
<b>Power terminal</b> Mounting screws Mounting torque	M5 x 9 2.4Nm

## Thermal Specifications

	RM1...M25	RM1...M50	RM1.60M50	RM1...M75	RM1...M100
<b>Operating temperature range</b>	-20° to 70°C	-20° to 70°C	-20° to 70°C	-20° to 70°C	-20° to 70°C
<b>Storage temperature range</b>	-40° to 100°C	-40° to 100°C	-40° to 100°C	-40° to 100°C	-40° to 100°C
<b>Junction temperature</b>	≤ 125°C	≤ 125°C	≤ 125°C	≤ 125°C	≤ 125°C
<b>R<sub>th</sub> junction to case</b>	≤ 0.80K/W	≤ 0.50K/W	≤ 0.72K/W	≤ 0.35K/W	≤ 0.30K/W
<b>R<sub>th</sub> junction to ambient</b>	≤ 20.0K/W	≤ 20.0K/W	≤ 20.0K/W	≤ 20.0K/W	≤ 20.0K/W

## Output Specifications

	RM1A..M25	RM1A..M50	RM1A..M75	RM1A..M100
<b>Rated operational current</b> AC51 @ Ta=25°C AC53a @ Ta=25°C	25Arms 5Arms	50Arms 15Arms	75Arms 20Arms	100Arms 30Arms
<b>Min. operational current</b>	150mA	250mA	400mA	500mA
<b>Rep. overload current t=1 s</b>	< 55AACrms	< 125AACrms	< 150AACrms	< 200AACrms
<b>Non-rep. surge current t=10ms</b>	325Ap	600Ap	1150Ap	1900Ap
<b>Off-state leakage current @ rated voltage and frequency</b>	< 3mArms	< 3mArms	< 3mArms	< 3mArms
<b>I<sup>2</sup>t for fusing t=10ms</b>	< 525A <sup>2</sup> s	< 1800A <sup>2</sup> s	< 6600A <sup>2</sup> s	< 18000A <sup>2</sup> s
<b>On-state voltage drop @ rated current</b>	1.6Vrms	1.6Vrms	1.6Vrms	1.6Vrms
<b>Critical dV/dt off-state min.</b>	500V/μs	500V/μs	500V/μs	500V/μs
<b>Zero crossing detection</b>	Yes	Yes	Yes	Yes



## Heatsink Dimensions (load current versus ambient temperature)

### RM1...M25

Load current [A]	Thermal resistance [K/W]						Power dissipation [W]	$T_A$
	20	30	40	50	60	70		
25.0	2.70	2.34	1.98	1.61	1.25	0.89	28	
22.5	3.10	2.69	2.28	1.86	1.45	1.04	24	
20.0	3.61	3.13	2.65	2.18	1.70	1.23	21	
17.5	4.26	3.70	3.14	2.59	2.03	1.47	18	
15.0	5.14	4.47	3.80	3.14	2.47	1.80	15	
12.5	6.38	5.56	4.73	3.91	3.09	2.27	12	
10.0	8.25	7.19	6.14	5.08	4.02	2.97	9	
7.5	11.4	9.94	8.49	7.04	5.59	4.14	7	
5.0	17.7	15.4	13.2	11.0	8.74	6.51	4	
2.5	-	-	-	-	18.2	13.6	2	

Ambient temp. [ $\infty$ C]

### RM1...M50

Load current [A]	Thermal resistance [K/W]						Power dissipation [W]	$T_A$
	20	30	40	50	60	70		
50.0	1.03	0.86	0.70	0.53	0.37	0.20	61	
45.0	1.27	1.09	0.90	0.71	0.52	0.33	53	
40.0	1.54	1.32	1.10	0.89	0.67	0.45	46	
35.0	1.85	1.59	1.34	1.08	0.82	0.57	39	
30.0	2.26	1.95	1.65	1.34	1.03	0.72	33	
25.0	2.85	2.47	2.08	1.70	1.32	0.96	26	
20.0	3.73	3.24	2.75	2.26	1.77	1.27	20	
15.0	5.22	4.54	3.86	3.19	2.51	1.83	15	
10.0	8.21	7.16	6.11	5.05	4.00	2.95	10	
5.0	17.2	15.0	12.9	10.7	8.51	6.33	5	

Ambient temp. [ $\infty$ C]

Junction to ambient thermal resistance, $R_{th\ j-a}$	< 20.0	K/W
Junction to case thermal resistance, $R_{th\ j-c}$	< 0.80	K/W
Case to heatsink thermal resistance, $R_{th\ c-s}$	< 0.20	K/W
Maximum allowable case temperature	100	deg.C
Maximum allowable junction temperature	125	deg.C

Junction to ambient thermal resistance, $R_{th\ j-a}$	< 20.0	K/W
Junction to case thermal resistance, $R_{th\ j-c}$	< 0.50	K/W
Case to heatsink thermal resistance, $R_{th\ c-s}$	< 0.20	K/W
Maximum allowable case temperature	100	deg.C
Maximum allowable junction temperature	125	deg.C

### RM1.60..50

Load current [A]	Thermal resistance [K/W]						Power dissipation [W]	$T_A$
	20	30	40	50	60	70		
50.0		0.81	0.63	0.44	0.26	0.08	5	
45.0	1.28	1.07	0.86	0.65	0.44	0.23	48	
40.0	1.64	1.40	1.15	0.91	0.67	0.42	41	
35.0	2.11	1.82	1.54	1.25	0.96	0.67	35	
30.0	2.60	2.25	1.90	1.55	1.20	0.85	29	
25.0	3.30	2.86	2.43	1.99	1.55	1.11	23	
20.0	4.36	3.79	3.22	2.65	2.08	1.51	18	
15.0	6.1	5.4	4.6	3.77	2.97	2.18	13	
10.0	9.76	8.52	7.3	6.0	4.8	3.54	8	
5.0	--	--	15.47	12.85	10.24	7.6	4	

Ambient temp. [ $\infty$ C]

### RM1...M75

Load current [A]	Thermal resistance [K/W]						Power dissipation [W]	$T_A$
	20	30	40	50	60	70		
75.0	0.91	0.78	0.65	0.52	0.39	0.26	77	
67.5	1.10	0.96	0.81	0.66	0.51	0.36	68	
60.0	1.34	1.17	1.00	0.83	0.66	0.49	59	
52.5	1.60	1.40	1.20	1.00	0.80	0.60	50	
45.0	1.93	1.68	1.44	1.20	0.96	0.72	42	
37.5	2.38	2.08	1.78	1.49	1.19	0.89	34	
30.0	3.06	2.68	2.30	1.91	1.53	1.15	26	
22.5	4.21	3.68	3.16	2.63	2.10	1.58	19	
15.0	6.51	5.70	4.88	4.07	3.26	2.44	12	
7.5	13.5	11.77	10.09	8.41	6.73	5.04	6	

Ambient temp. [ $\infty$ C]

Junction to ambient thermal resistance, $R_{th\ j-a}$	< 20.0	K/W
Junction to baseplate case thermal resistance, $R_{th\ j-c}$	< 0.72	K/W
Case to heatsink thermal resistance, $R_{th\ c-s}$	< 0.20	K/W
Maximum allowable heatsink temperature	100	deg.C
Maximum allowable junction temperature	125	deg.C

Junction to ambient thermal resistance, $R_{th\ j-a}$	< 20.0	K/W
Junction to case thermal resistance, $R_{th\ j-c}$	< 0.35	K/W
Case to heatsink thermal resistance, $R_{th\ c-s}$	< 0.10	K/W
Maximum allowable heatsink temperature	100	deg.C
Maximum allowable junction temperature	125	deg.C



## Heatsink Dimensions

(load current versus ambient temperature) cont.d

### RM1...M100

Load current [A]	Thermal resistance [K/W]						Power dissipation [W]
	20	30	40	50	60	70	
100.0	0.54	0.45	0.36	0.27	0.18	0.09	111
90.0	0.68	0.58	0.47	0.37	0.27	0.17	97
80.0	0.86	0.74	0.62	0.50	0.38	0.26	84
70.0	1.08	0.94	0.80	0.66	0.52	0.38	71
60.0	1.37	1.20	1.03	0.85	0.68	0.51	59
50.0	1.70	1.49	1.28	1.06	0.85	0.64	47
40.0	2.21	1.93	1.66	1.38	1.10	0.83	36
30.0	3.06	2.68	2.30	1.91	1.53	1.15	26
20.0	4.78	4.18	3.59	2.99	2.39	1.79	17
10.0	9.98	8.73	7.49	6.24	4.99	3.74	8

$T_A$   
 Ambient temp. [ $\infty$ C]

Junction to ambient thermal resistance, $R_{th\ j-a}$	< 20.0	K/W
Junction to case thermal resistance, $R_{th\ j-c}$	< 0.30	K/W
Case to heatsink thermal resistance, $R_{th\ c-s}$	< 0.10	K/W
Maximum allowable heatsink temperature	100	deg.C
Maximum allowable junction temperature	125	deg.C

## Functional Diagram

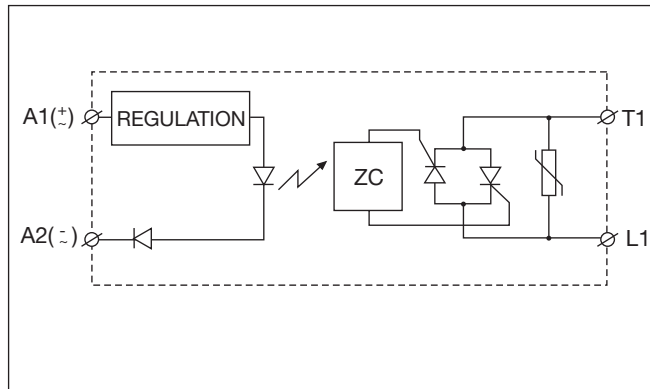

## Heatsink Selection

Carlo Gavazzi Heatsink (see Accessories)	Thermal resistance...	...for power dissipation
No heatsink required	---	N/A
RHS 300	5.00 K/W	> 0 W
RHS 100	3.00 K/W	> 25 W
RHS 45C	2.70 K/W	> 60 W
RHS 45B	2.00 K/W	> 60 W
RHS 90A	1.35 K/W	> 60 W
RHS 45C plus fan	1.25 K/W	> 0 W
RHS 45B plus fan	1.20 K/W	> 0 W
RHS 112A	1.10 K/W	> 100 W
RHS 301	0.80 K/W	> 70 W
RHS 90A plus fan	0.45 K/W	> 0 W
RHS 112A plus fan	0.40 K/W	> 0 W
RHS 301 plus fan	0.25 K/W	> 0 W
Consult your distribution	> 0.25 K/W	N/A
Infinite heatsink - No solution	---	N/A

## Dimensions

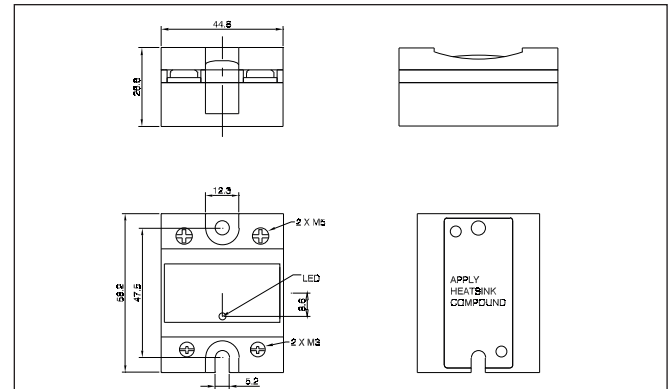

All dimensions in mm.



## Environmental Information

The declaration in this section is prepared in compliance with People's Republic of China Electronic Industry Standard SJ/T11364-2014: Marking for the Restricted Use of Hazardous Substances in Electronic and Electrical Products.

Part Name	Toxic or Harardous Substances and Elements					
	Lead (Pb)	Mercury (Hg)	Cadmium (Cd)	Hexavalent Chromium (Cr(VI))	Polybrominated biphenyls (PBB)	Polybrominated diphenyl ethers (PBDE)
Power Unit Assembly	x	○	○	○	○	○

O: Indicates that said hazardous substance contained in homogeneous materials for this part are below the limit requirement of GB/T 26572.

X: Indicates that said hazardous substance contained in one of the homogeneous materials used for this part is above the limit requirement of GB/T 26572.

## 环境特性

这份申明根据中华人民共和国电子工业标准 SJ/T11364-2014：标注在电子电气产品中限定使用的有害物质

零件名称	有毒或有害物质与元素					
	铅 (Pb)	汞 (Hg)	镉 (Cd)	六价铬 (Cr(VI))	多溴化联苯 (PBB)	多溴联苯醚 (PBDE)
功率单元	x	○	○	○	○	○

O:此零件所有材料中含有的该有害物低于GB/T 26572的限定。

X: 此零件某种材料中含有的该有害物高于GB/T 26572的限定。



## Faston terminals



- Faston tabs
- Tab dimension according to DIN 46342 part 1
- Pure tin-plated brass

### Ordering Key

#### Screw mounted Faston terminals

**RM1A48M25 F 4\***

RS, RM Solid State Relay  
Faston terminals

Tab orientation  
Input Tab width: 4.8mm  
Output Tab width: 6.3mm

#### Faston terminals in packs of 20

**RM48\*\* F4\***

RS, RM Solid State Relay  
Tab orientation

- \* 0: Flat (0°)
- 4: Angled (45°)

- \*\* 48: 4.8mm faston for input
- 63: 6.3mm faston for output

## Fork Terminals

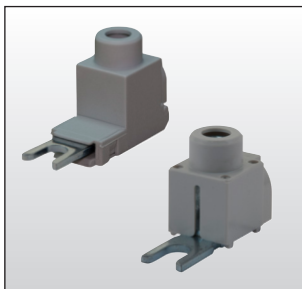

- Terminal adaptors for 35mm<sup>2</sup> cable
- Type RM635FK
- Pack size: 10 pieces

### Ordering Key

**RM635FK P**

RM terminal adaptor  
Touch protected (optional)

## Other Accessories

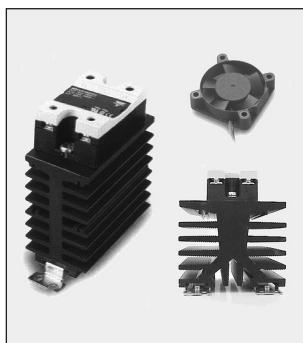

- Heatsinks and fans
- Type RHS....
- 0.25 to 5.00 k/W
- Single and dual relay types

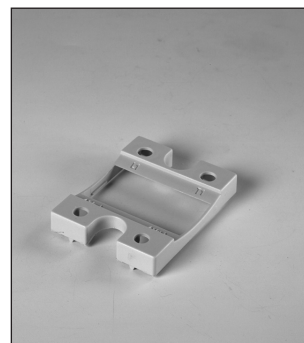

- Touch safety cover
- Type RMIP20
- IP20 protection degree
- Pack size: 20 pieces

All accessories can be ordered pre-assembled with Solid State Relays. Other accessories include DIN rail adaptors, fuses, varistors and spacers. For further information refer to Accessories datasheets.

## X-ON Electronics

Largest Supplier of Electrical and Electronic Components

*Click to view similar products for [Solid State Relays - Industrial Mount](#) category:*

*Click to view products by [Carlo Gavazzi](#) manufacturer:*

Other Similar products are found below :

[6225XXASRS-DC3](#) [D2440-C](#) [H10CA4890](#) [D4875C](#) [D53TP50DH-10](#) [1395831-1](#) [1616010-6](#) [BR312BY](#) [A-1326](#) [AQY210SXE01](#)  
[AQY221N2SYD01](#) [AQY414SXE01](#) [26532764](#) [H10CA4850](#) [H12CA4890VL](#) [RA2410-D06](#) [D1202F](#) [D53TP50-10](#) [W230E-1-12](#) [W230T-3-](#)  
[12](#) [W6125ASX-1](#) [W6225DSX-2](#) [W6240DSX-4](#) [W6240DTX-2](#) [1-1617030-3](#) [1-1617033-9](#) [1-1617033-7](#) [MS2-D2420](#) [MS2-D2430](#) [A-1440](#)  
[4-1617080-0](#) [RJ1P60V50E](#) [RN1F48I50](#) [70.362.1028.0](#) [7-1393030-8](#) [Z5.509.0828.0](#) [W230E-2-5](#) [G3RV-SR700-D](#) [AC110](#) [G3RV-SR500-AL](#)  
[AC100](#) [G3RV-SR500-D](#) [ACDC24](#) [G3RV-SR500-AL](#) [ACDC24](#) [G3RV-SR700-D](#) [ACDC24](#) [G3RV-SR700-AL](#) [ACDC24](#) [G3RV-SR500-D](#)  
[DC12](#) [G3RV-SR700-A](#) [ACDC24](#) [G3RV-SR500-A](#) [ACDC24](#) [2912138](#) [2912141](#) [SSRDAC10](#) [1613353](#)