

Switching Power Supply Type SPD 240W Compact DIN rail mounting

CARLO GAVAZZI



- Universal AC input full range
- Installation on DIN rail 7.5 or 15mm
- Short circuit protection
- Active PFC as standard
- High efficiency up to 93%
- Power ready output
- LED indicator for DC power ON
- LED indicator for DC low
- Parallel connection feature
- Compact dimensions
- UL, cUL listed and TUV/CE approved
- 150% peak load capability

Product Description

The Switching power supplies SPD series are specially designed to be used in all automation application where the installation is on a DIN rail and compact dimensions and performance are a must.

Ordering Key

SP D 24 240 1C X

Model _____
 Mounting (D = Din rail) _____
 Output voltage _____
 Output power _____
 Input type _____
 Optional features _____

Input type: 1C = single phase Compact version

Approvals



Optional features

Description	Code
Screw terminal	Nil
Plug-in connectors	B

Output Performance

MODEL NO.	INPUT VOLTAGE	OUTPUT POWER	OUTPUT VOLTAGE	OUTPUT CURRENT	EFF. (min.)	EFF. (typ.)
Single Output Models						
SPD 12 240 1C X	88~264 VAC	192 WATTS	+12 VDC	16A	89%	91%
SPD 24 240 1C X	88~264 VAC	240 WATTS	+ 24 VDC	10A	91%	93%

Output Data (All specifications are at nominal values, full load, 25°C unless otherwise noticed)

Line regulation	± 1%	Reverse voltage	12V Model 18VDC 24V Model 35VDC
Load regulation	±1%	Capacitor load	7000µF
Minimum load	0%	Temperature coefficient	±0.03°C
Turn on time		DC ON indicator threshold at start up (Green LED)	VDC
Vi nom, lo nom	1000ms (full resistive load) 150ms with 7000µF CAP	Vi nom, lo nom 12V Model 10 24V Model 17.6	Min. Max. 11.2 19.4
Transient recovery time	2ms	DC LOW indicator threshold at start up (Red LED)	VDC
Ripple and noise	100mVpp	Vi nom, lo nom 12V Model 10 24V Model 17.6	Min. Max. 11.2 19.4
Output voltage accuracy	0% ~ +1%	Parallel operation	0.1 lo min~0.9 lo max For parallel operation, turn the Switch S/P Single/Parallel to the position "P" in advance. Max 3 units and power out 90%
Hold up time Vi= 115VAC Vi= 230VAC	25ms 30ms		
Voltage fall time (I _o nom, Vi nom)	150ms		
Voltage rise time Vi nom, lo nom	150ms (full resistive load) 500ms with 7000µF CAP		
Voltage trim range	12V Model 11.4-14.5 VDC 24V Model 22.5-28.5 VDC		
Rated continuous loading	12V Model 16A@12VDC/13A@14.5VDC 24V Model 10A@24VDC/8.4A@28.5VDC		

Input Data (All specifications are at nominal values, full load, 25°C unless otherwise noticed)

Rated input voltage I_{nom}	100 - 240VAC	Power dissipation (V_i : 230VAC, I_o nom)	12V Model 24V Model	19W 18W
Voltage range		Frequency range	47- 63Hz	
AC IN	88 - 264VAC	Leakage current	Input-Output	<0.25mA
DC IN	120 - 375VDC		Input-FG	<3.5mA
Rated input current		P.F.C. (Active)	0.97@ V_i :230VAC, I_o nom	
V_i: 88VAC I_o nom	3.2A Max.			
V_i: 115VAC I_o nom	2.3A Typ.			
V_i: 230VAC I_o nom	1.15A Typ.			
Inrush current				
V_i= 115VAC	24A			
V_i= 230VAC	48A			

Controls and Protections (All specifications are at nominal values, full load, 25°C unless otherwise noticed)

Overload V_i nom (see typ current limited curve)	120% - 150%	Power RDY (for 24V model only)	Threshold voltage of contact closed (at start up) 17.6 - 19.4VDC	
Input fuse	T5A/250VAC internal ¹⁾	Electrical isolation	500VDC	
Output short circuit	Shut-down protection, after 7s auto-restart	Over temperature Detect on heat sink, shut down O/P voltage, recovers automatically after temperature goes down	100 - 110°C	
Over voltage protection (Auto recovery)	VDC	Rated over load protection V_i nom (see typ current limited curve)	120 - 150%	
12V Model	Min. 15	Max. 16.5		
24V Model	30	33		
Internal surge voltage protection IEC 61000-4-5	Varistor			

¹⁾ Fuse not replaceable by user

General Data (All specifications are at nominal values, full load, 25°C unless otherwise noticed)

Ambient temperature	-40°C to + 71°C	Pollution degree	2
Derating (+61°C to + 71°C)	2.5%/°C (see curve)	MTBF (Bellcore issue 6 @ 40°C, GB)	
Relative humidity	20 ~ 95%RH	12V Model	374000 Hours
Storage temperature	-40°C to +85°C	24V Model	384000 Hours
Protection degree	IP20	Case material	Metal
Cooling	Free air convection	Altitude	4850m
Insulation voltage		Dimensions LxWxD mm(inch)	
Input-Output	3000VAC/4242VD min	Screw terminal type	124.5(4.9)x64(2.52)x123.6(4.87)
Input-Fg	1500VAC/2121VD min	Detachable connector type	143.5(5.65)x64(2.52)x123.6(4.87)
Insulation resistance I/O	100MΩ min (@ 500VDC)	Weight	860g
Switching Frequency	90 Khz Typ	Packing	960g

Norms and Standards

Vibration resistance	meet IEC 60068-2-6 (Mounting by rail: Random wave, 10-500 Hz, 2G each long Z, Y, Z axes 10 min/cycle, 60min.)	CE	EN 61000-6-3, EN 55037 Class B, EN 61000-3-2, EN 61000-3-3, EN 61000-6-2, EN 55024, EN 61000-4-2 level 4, EN 61000-4-3 level 3 EN 61000-4-4 level 4 EN 61000-4-5 L-N level 3 EN 61000-4-6 level 3 EN 61000-4-8 level 4 EN 61000-4-11, ENV 50204 Level 2
Shock resistance	meet IEC 60068-2-27 (4G, 22ms, 3 Axis, 6 faces, 3 times for each face)		
UL/cUL	UL 508 Listed UL 60950-1 Recognized		
TUV	EN 60950-1 EN 21558-1 EN 6155-8-2-16		

Block Diagram

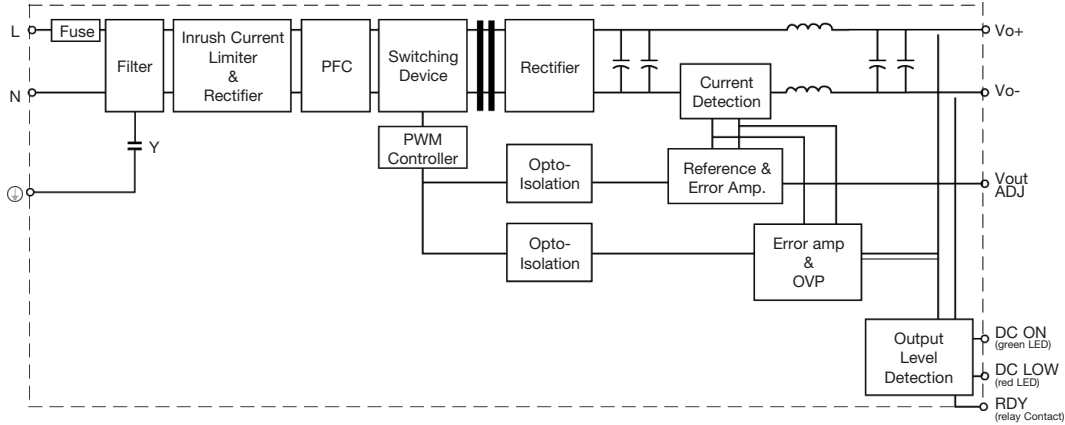

Pin Assignment and Front Controls

Pin No.	Designation	Description
1	RDY	A normal open relay contact for DC ON level control Never connect except 24V model
2		
3. 4	V+	Positive output terminal
5. 6	V-	Negative output terminal
7	⊕	Ground this terminal to minimize high-frequency emissions
8	N	Input terminals (neutral conductor, no polarity at DC input)
9	L	Input terminal (phase conductor, no polarity at DC input)
LED	DC ON	Operation indicator LED
LED	DC LO	DC LOW voltage indicator LED
Trimmer	Vout ADJ.	Trimmer-potentiometer for Vout adjustment
Switch	S/P	Single / Parallel select switch

Derating Curve

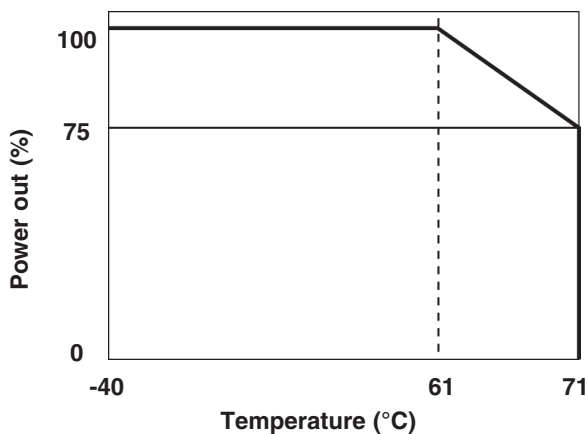

Typ. Efficiency curve

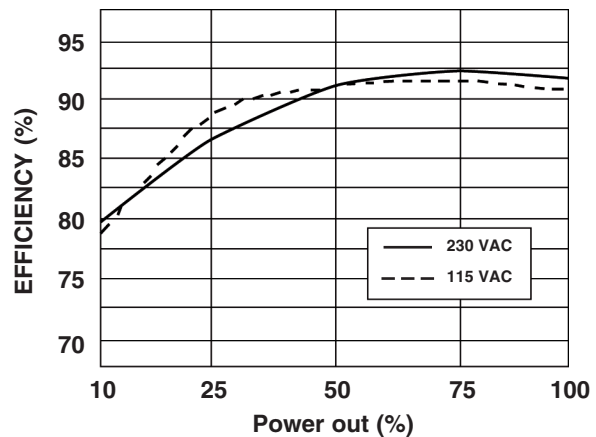

Typ. Current Limited Curve

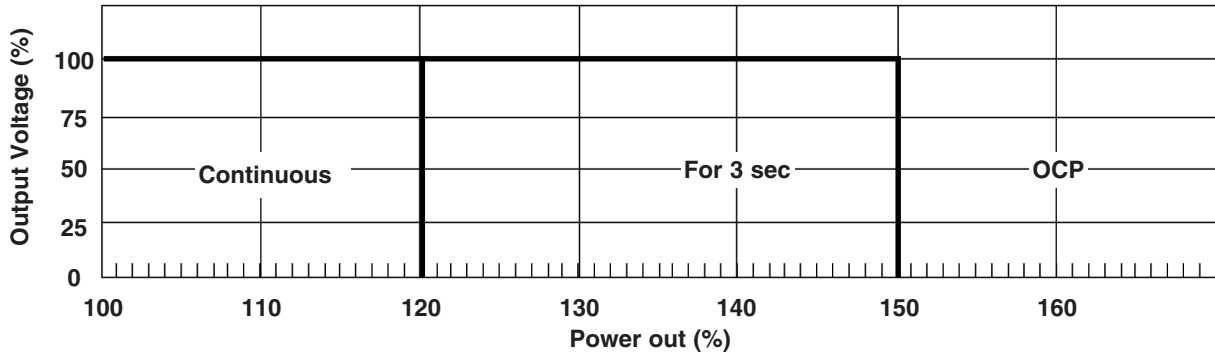

Peak Loading

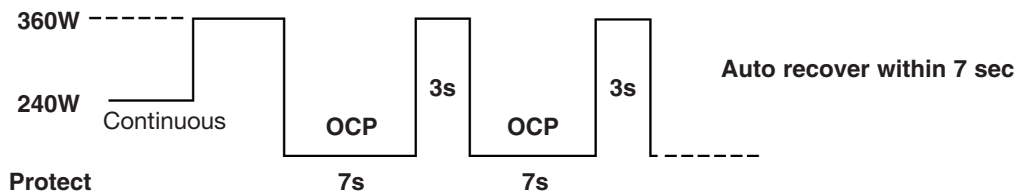

Mechanical Drawings mm (inches)

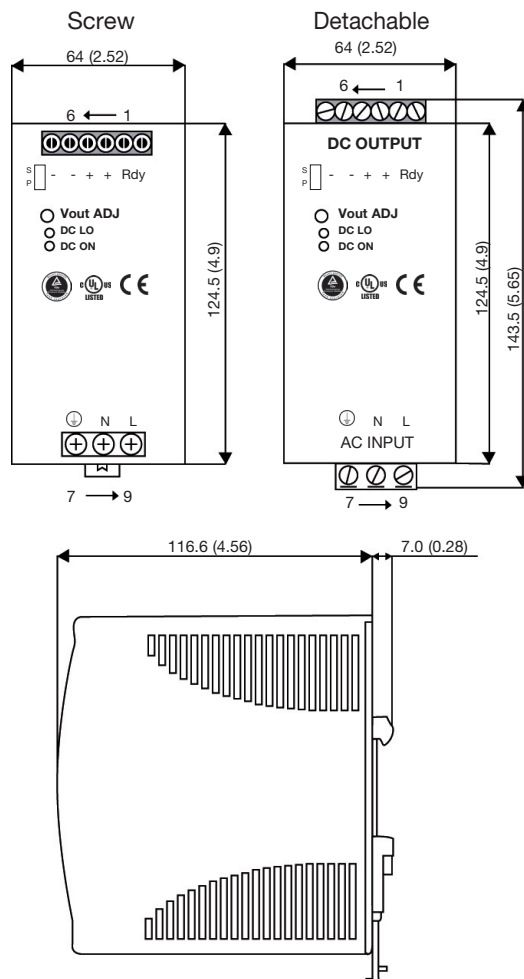

Installation

Ventilation and cooling

Normal convection.
 All sides 25mm free space for cooling is recommended

Connector size range Screw terminals:

- Input Terminals
- Output Terminals

Detachable connectors:

- Input Terminals
- Output Terminals

Screw terminals:
 AWG24-10 (0.2~4mm²) flexible / solid cable, max. torque at 1.16Nm (9 pound-inches).

Detachable connectors:
 AWG24-12 (0.2~2.5 mm²) flexible / solid cable, max. torque at 0.51 Nm (4.5 pound-inches). max. torque at 0.79 Nm (7 pound-inches). 4~5mm stripping at cable end recommends. Use copper conductors only, 60/75°C.

Parallel Connection

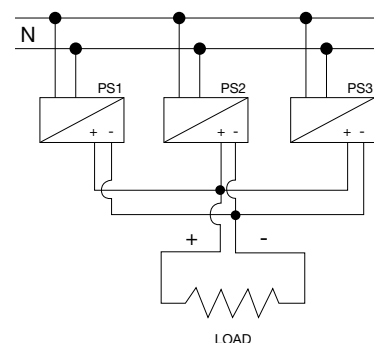

X-ON Electronics

Largest Supplier of Electrical and Electronic Components

Click to view similar products for [DIN Rail Power Supplies](#) category:

Click to view products by [Carlo Gavazzi](#) manufacturer:

Other Similar products are found below :

[PS-S6024](#) [DVP01PU-S](#) [DVP06AD-S](#) [DVP06XA-S](#) [DVDPNET-SL](#) [DVPDT01-S](#) [DVPPS01](#) [PS-6012](#) [PS9Z-5R1G](#) [PS-C24024](#)
[DVP08ST11N](#) [DVPACAB530](#) [DVPCOPM-SL](#) [DVPEN01-SL](#) [DVPPF01-S](#) [ADNB008-48-1PM-C](#) [ADNB017-24-1PM-C](#) [ADNB040-24-1PM-C](#) [ADNB050-12-1PM-C](#) [ADNB040-15-1PM-C](#) [ADNB034-12-1PM-C](#) [S8TS-06024-E1](#) [PS-UPS40](#) [PSC-6024](#) [PSD-A60W12](#) [96PS-A120WDIN](#) [PSD-A60W48](#) [PSD-A40W12](#) [PSD-A40W24](#) [SMP21-L20-DC24V-5A](#) [PSD-A40W48](#) [S8T-DCBU-02](#) [PS-S4024](#) [NTPS-24-1.3](#)
[PST-96024](#) [S82YVSC4P](#) [PS-S4005](#) [PS-10024](#) [PS-S10024](#) [PS-C12024](#) [PSP-480S24](#) [PS-C48024](#) [PSC-2024](#) [PSC-4012](#) [PSC-4015](#) [PSC-4048](#)
[PSC-9615](#) [PSC-15124](#) [PSC-15148](#) [PSC-24148](#)