

# Energy Management Control solution for solar PV applications Type Eos-Array Lite

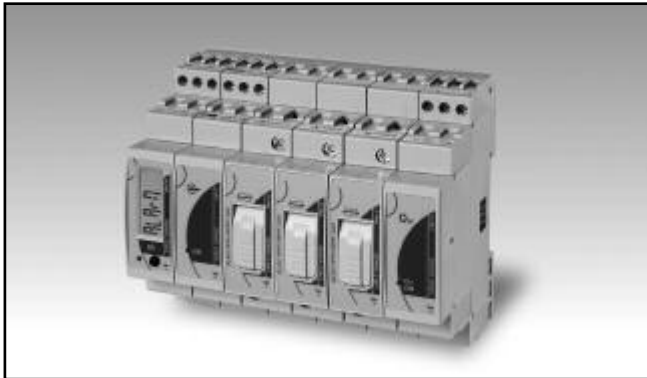

- Modular local control system for PV plants
- Up to 17 DIN modules configuration equivalent to 280mm width
- Eos-ArrayLSoft freeware software for easy product configuration
- Eos-Array can be formed by maximum 17 units
- Eos-Array can manage in addition to VMU-ML master unit up to:
  - max 1 VMU-P unit;
  - max 15 VMU-S0 units;
  - max 1 VMU-O units.
  - max 1 VMU-1

## VMU-ML, master unit



- Master communication capability
- RS485 communication port (Modbus)
- Local communication bus management up to 15 mixed VMU-S0, VMU-P and VMU-O units
- Single virtual or real alarm set-point connectable to any available variable
- Display readout: 6 DGTs
- 12 to 28 VDC power supply
- Dimensions: 1-DIN module
- Protection degree (front): IP40

## Product Description

Eos-Array Lite is a combination of modules which performs mainly a current and voltage control of a photovoltaic plant. The core unit is VMU-ML which performs the local bus management of VMU-S0, VMU-P both measuring units and VMU-O output unit. VMU-ML assigns the proper local unit address

automatically (up to 15 units) and gathers all the local measurements coming from VMU-S0 and VMU-P measuring units. VMU-ML can provide by means of VMU-O modules one relay output so to manage up to 1 real alarm. Housing for DIN-rail mounting, IP40 (front) protection degree.

## How to order

**VMU-M L A S1 XX X**

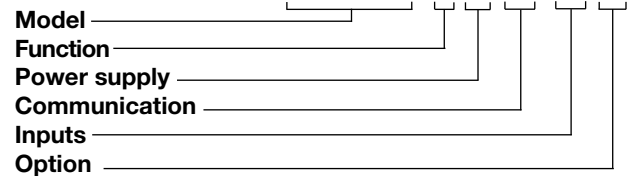

## Type Selection

Function	Power supply	Communication	Inputs
L: Lite (*)	A: From 12 to 28VDC (*)	S1: RS485 Modbus (*)	XX: none (*)
Option	(*) as standard.		
X: none			

## VMU-S0, string measuring unit



- Direct DC voltage measurement up to 1000V
- Direct DC current measurement up to 16A or up to 30A without fuse
- Instantaneous variables data format: 4 DGTs
- Instantaneous variables: V, A.
- Accuracy:  $\pm 0.5$  RDG (current/voltage)
- Auxiliary power supply from VMU-ML unit
- String alarm management by means of VMU-ML unit
- Integrated 10.3x38mm fuse holder for string protection
- Fuse blow detection by means of VMU-ML unit only
- Dimensions: 1-DIN module
- Protection degree (front): IP40

### Product Description

Variables measuring unit with built-in protection fuse-holder (the fuse is not provided), particularly indicated for DC current, voltage, metering in PV solar applications. The current inputs/outputs and also the voltage inputs are made so to simplify the string common connections. Direct

connection up to 16A or 30A. Moreover the unit is provided with an auxiliary serial communication bus. Alarms, fuse blow detection, and serial communication are managed by means of VMU-ML module. Housing for DIN-rail mounting, IP40 (front) protection degree.

### How to order **VMU-S0 AV10 X S FX**

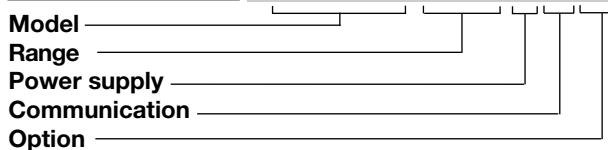

### Type Selection

Range	Power supply	Communication	Option
<b>AV10:</b> 1000V DC, 16A (Direct connection) (*)	<b>X:</b> from 12 to 28VDC, self-power supply from VMU-ML unit	<b>S:</b> auxiliary communication bus, compatible only to VMU-ML module (*)	<b>XX:</b> none (no fuse holder) <b>FX:</b> with fuse holder (*)
<b>AV30:</b> 1000V DC, 30A (Direct connection) (**) In this case the "Option" is "XX".			

(\*) as standard.  
 (\*\*) on request.

## VMU-1, isolation enhancement unit

---

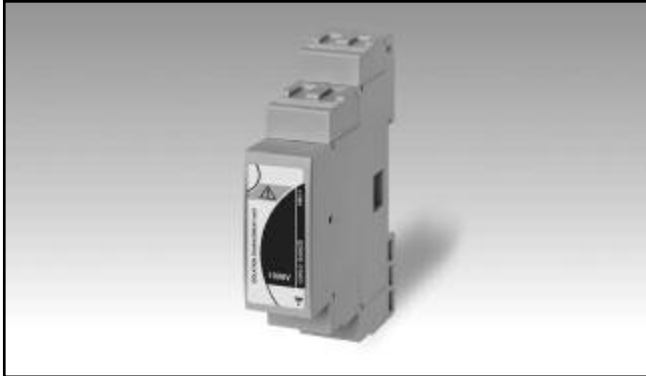

- Isolation enhancement of voltage measuring inputs to earth of VMU-S0: from 800VDC (without VMU-1) to 1000VDC max.
- Dimensions: 1-DIN module
- Protection degree (front): IP40

### Product Description

Isolation enhancement unit suitable to be used in combination with VMU modules. VMU-1 allows to enhance the isolation of the voltage measuring input to earth from 800VDC to 1000VDC.

The module is to be mounted between the first VMU-S0 and all the other VMU modules. Housing for DIN-rail mounting, IP40 (front) protection degree.

### How to order

**VMU-1 1000**

Standard model

### Type Selection

---

#### Standard model

**Isolation voltage 1000V:** isolation enhancement on VMU-S0 voltage measuring input to earth from 800VDC (without module) to 1000VDC.  
 Note: only one VMU-1 is needed per Eos-Array.

## VMU-P, environment variables unit



- **Measurements:** PV module temperature or air temperature, sun irradiation
- **One temperature input:** Pt100 or Pt1000 type
- **One 120mV or 20mA DC input with scaling capability for irradiation measurement**
- **Auxiliary communication bus to VMU-ML unit**
- **Auxiliary power supply from VMU-ML unit**
- **Dimensions:** 1-DIN module
- **Protection degree (front):** IP40

### Product Description

Environment variables measurement unit particularly indicated for PV module temperature or air temperature and sun irradiation, metering in PV solar applications. Moreover the unit is

provided with a specific serial communication bus, which is managed by means of the additional VMU-ML module. Housing for DIN-rail mounting, IP40 (front) protection degree.

### How to order **VMU-P 1TI X S X**



### Type Selection

Range	Power supply	Communication	Option
<b>1TI:</b> One "Pt" temperature type probe, mV sun irradiation input (*)	<b>X:</b> from 12 to 28VDC, self-power supply from VMU-ML unit	<b>S:</b> auxiliary communication bus, compatible only to VMU-ML module (*)	<b>X:</b> none
<b>1TC:</b> One "Pt" temperature type probe, mA sun irradiation input (*)			

(\*) as standard.

## VMU-O, relay outputs unit

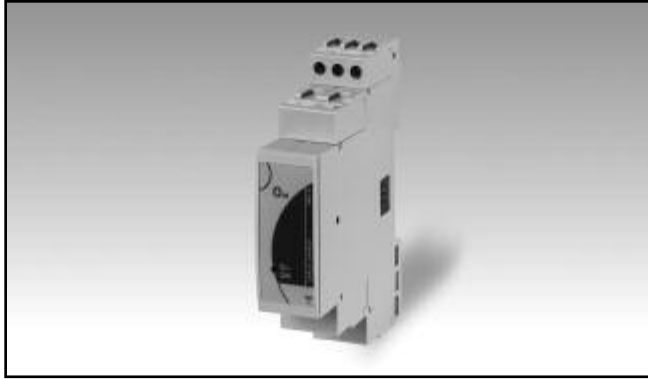

- One relay output managed by the VMU-ML module
- Auxiliary power supply from VMU-ML unit
- Dimensions: 1-DIN module
- Protection degree (front): IP40

### VMU-O Product Description

Relay output unit suitable to be used in combination with VMU-ML module. VMU-O allows to add one relay output to a VMU-ML based

system so to manage local alarms. Housing for DIN-rail mounting, IP40 (front) protection degree.

### How to order

**VMU-O X XX R1 X**

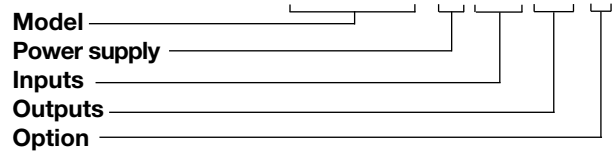

### Type Selection

Power supply	Inputs	Outputs	Option
<b>X:</b> from 12 to 28VDC, self-power supply from VMU-ML unit (*)	<b>XX:</b> none	<b>R1:</b> one relay output (*)	<b>X:</b> none

(\*) as standard.



## VMU-ML Display and LED specifications

<b>Display</b>	1 line (max: 6-DGT)	Green blinking light: the communication on the RS485 bus is working. Red: alarm detected (any). In case of alarm/communication condition the LED alternates its colour from red (alarm) to green. The blinking time is approx. 1 second.
Type Information read-out	LCD, h 7mm 4-DGT	
<b>LED</b>		
Type Status and colour	Dual colour Green steady light: the module is power supplied and there is no communication on the RS485 bus.	

## VMU-P LED specifications

<b>LED</b>		White: the unit is enabled by VMU-ML module for data reading and displaying.
Type Status and colour	Multicolor Green: the power supply is ON.	

## VMU-O LED specifications

<b>LED</b>		activated. Cycling from one colour to any other one: the unit shows the status of the module according to the colour list above. The cycling time is approx. 1 second.
Type Status and colour	Multicolor Green: the power supply is ON. White: the unit is enabled by VMU-ML module for data reading and displaying. Blue: digital output is	

## VMU-ML input specifications

<b>Key-pad</b>	1 push-button for variable scrolling and for some parameters programming.	Full programming can be carried out only using Eos-ArrayLSoft.
----------------	---	--

## VMU-S0 input specifications

<b>Rated inputs</b>		Start up current	0.05A
Current type	1 (shunt)	Start up voltage	10V
Current range	AV10 range: 16A DC @ 40°C, 15A @ 50°C, 14A @ 55°C, 12A @ 60°C, 10A @ 65°C AV30 range: 30A DC @ 55°C, 25A DC @ 60°C, 20A DC @ 65°C	AV30 range code	
		Current	$\pm(0.5\%RDG+2 \text{ DGT})$ from 0.2A to 30A
		Voltage	$\pm(0.5\%RDG+2 \text{ DGT})$ from 20V to 1000V
Voltage	AV10 range: 1000V DC AV30 range: 1000V DC	Start up current	0.2A
		Start up voltage	10V
		<b>Temperature drift</b>	$\leq 200\text{ppm}/^\circ\text{C}$
<b>Accuracy</b>	(@25°C $\pm 5^\circ\text{C}$ , R.H. $\leq 60\%$ )	<b>Measurement sampling time</b>	2 sec.
AV10 range code		<b>Variables format</b>	
Current	$\pm(0.5\%RDG+2 \text{ DGT})$ from 0.05A to 16A	Instantaneous variables	4-DGT (A), 5-DGT (V)
Voltage	$\pm(0.5\%RDG+2 \text{ DGT})$ from 20V to 1000V	Resolution	0.1V; 0.01A.

## VMU-S0 input specifications (cont.)

<b>Max. and Min. data format</b> <b>Input impedance</b> AV10 range code Voltage Current  AV30 range code Voltage Current	See "Variables format"  > 2.5MΩ < 0.006Ω(+ fuse impedance) @ 0.5 Nm (screw terminal torque). The maximum dissipation power has not to exceed 2W.  > 2.5M < 0.003Ω @ 0.5 Nm (screw terminal torque)	<b>Current Overloads</b> Continuous  For 1s  <b>Protection</b> Fuse holder Fuse type Fuse size Fuse current	AV10 range: 16A AV30 range: 30A AV10 range: 100A max AV30 range: 150A max  Integrated into the module gPV 10x38mm (IEC60269-1-6) Fuse NOT provided. Note: the fuse rated current has to be $\geq 1.4$ Isc at 45°C ambient temperature. See fuse manufacturer specifications for further details including de-rating caused by higher ambient temperature.
<b>Voltage Overloads</b> Continuous For 500ms To earth	1100V 1600V 800V (extended to 1000V in case of combined use of VMU-1.1000V unit)		

## VMU-P input specifications

<b>Temperature drift</b> <b>Variables format</b> Instantaneous variables  Resolution	$\leq 200\text{ppm}/^{\circ}\text{C}$  4 DGT (Temperature, solar irradiation) 0.1°C/0.1°F; 1W/m <sup>2</sup> , 1W/ft <sup>2</sup> ;	Decimal point position Impedance Overload Continuous  For 1s Insulation	Fixed. > 30KΩ  10VDC (measurement available up to 1V on both display and communication bus) 20VDC See the table "Insulation between inputs and communication bus"
<b>Max. and Min. data format</b> <b>Temperature probe input</b> Number of inputs Temperature probe Number of wires Wire compensation Accuracy (@25°C ±5°C, R.H. ≤60%) (Display + RS485)  Temperature drift Engineering unit Insulation	See "Variables format"  1 Pt100 or Pt1000 Up to 3-wire connection Up to 10Ω.  See table "Temperature input characteristics" ±150ppm /°C Selectable °C or °F See the table "Insulation between inputs and communication bus"	Irradiation sensor inputs (range code: 1TC) Number of inputs Range Accuracy (Display + RS485) (@25°C ±5°C, R.H. ≤60%)  Temperature drift Scaling factor Operating mode	1 0 to 20mA DC  ±(0.2%RDG+1DGT) 0% to 25% FS; ±(0.1%RDG+1DGT) 25% to 120% FS. ±150ppm /°C
<b>Irradiation sensor inputs (range code: 1TI)</b> Number of inputs Range Accuracy (Display + RS485) (@25°C ±5°C, R.H. ≤60%)  Temperature drift Scaling factor Operating mode	1 0 to 120mVDC  ±(0.2%RDG+1DGT) 0% to 25% FS; ±(0.1%RDG+1DGT) 25% to 120% FS. ±150ppm /°C  Dual scale: - Input: programmable range from 0 to 150.0 (mVDC) - Display: programmable range from 0 to 9999 (kW/m <sup>2</sup> , kW/ft <sup>2</sup> )	Temperature drift Impedance Overload Continuous  For 1s Insulation	Dual scale: - Input: programmable range from 0 to 25.0 (mADC) - Display: programmable range from 0 to 9999 (kW/m <sup>2</sup> , kW/ft <sup>2</sup> ) Fixed. $\leq 23\Omega$  50mADC (measurement available up to 25mA on both display and communication bus) 150mADC See the table "Insulation between inputs and communication bus"

## VMU-P Temperature input characteristics

Probe	Range	Accuracy (@25°C ±5°C, R.H. ≤60%)	Min Indication	Max Indication
Pt100	-50°C to +200.0°C	±(0.5%RDG +5DGT)	-50.0	+200.0
Pt100	-58°F to +392°F	±(0.5%RDG +5DGT)	-58.0	+392.0
Pt1000	-50°C to +200.0°C	±(0.5%RDG +5DGT)	-50.0	+200.0
Pt1000	-58°F to +392°F	±(0.5%RDG +5DGT)	-58.0	+392.0

## VMU-ML Output specifications

<b>RS485</b>	Slave function	<b>Auxiliary communication bus</b>	<p>This is the communication bus to the VMU-S0, VMU-P and VMU-O units where VMU-ML performs the master function in this network. VMU-ML unit can gather the following information from the bus:</p> <ul style="list-style-type: none"> <li>- All variables available on the bus;</li> <li>- Antitheft status;</li> <li>- PV reverse voltage and current polarity;</li> <li>- PV module status.</li> </ul> <p>The local address in the VMU-S0, VMU-P and VMU-O units is automatically assigned by VMU-ML master unit based on their positions. It can manage up to 15 different addresses (units). See the table "Insulation between inputs and outputs"</p>
Type	Multidrop, bidirectional (static and dynamic variables)		
Connections	2-wire. Max. distance 1000m		
Addresses	247, selectable by means of the front push-button		
Protocol	MODBUS/JBUS (RTU)		
Data (bidirectional)			
Dynamic (reading only)	All variables, see "List of the variables that can be..."		
Static (writing only)	All the configuration parameters.		
Data format	1 start bit, 8 data bit, no parity, 1 stop bit		
Baud-rate	Selectable: 9600, 19200, 38400, 115200 bits/s Parity: none		
Driver input capability	1/5 unit load. Maximum 160 transceivers on the same bus.		
Special functions	None	Insulation	
Insulation	See the table "Insulation between inputs and outputs"		

## VMU-O Output specifications

<b>Maximum number of modules managed by every single VMU-ML module</b>	Up to 1	Type	Relay, SPST type AC 1-5A @ 250VAC AC 15-1A @ 250VAC Available by means of VMU-O module only See the table "Insulation between inputs and outputs"
<b>Digital output</b>			
Number of outputs	1	Insulation	
Purpose	Alarm notification as a String alarm and other alarms (see "List of the variables that can be connected to...")		



## Main Function

<p><b>Displaying</b> VMU-ML module</p> <p>When a VMU-S0 module is selected</p> <p>When a VMU-P module is selected</p> <p>When a VMU-O module is selected</p>	<p>1 parameter per page “Alarm and diagnostics messages”</p> <p>All the information related to the status of the string being selected by means of the front key (see the table “List of the variables that can be...”).</p> <p>All the information related to the status of the environment probes being selected by means of the front key (see the table “List of the variables that can be...”).</p> <p>All the information related to the status of the output being selected by means of the front key (see the table “List of the variables that can be...”).</p>		<p>there are at least two string controls (VMU-S0 units). The highest value of the measured string current among those available is used as a reference value. The alarm set-point is a value that can be set by the user as a percentage of the reference value below which there is the alarm condition.</p> <p>- Median control: the measurement of the string power is performed by the local VMU-S0 module individually. Within the VMU-ML system all values coming at the same instant from every VMU-S0 module are used to calculate the “median” value which becomes the reference value to which the dynamic window set-point (in percentage set by the user) is linked. The abnormal condition is detected when the measured instantaneous string current is out of the set window alarm. The alarm activates, with reference to the failed string, either a relay output (only in case of “VMU-O” connection) or/and a message which is transmitted by means of the RS485 communication port to an acquisition system.</p> <p>The alarm is set as the string power control, the value is programmable in percentage (of the measured string value) from 0.1 to 199.9.</p> <p>The alarms can be connected also to the string voltage.</p>
<p><b>Password</b></p> <p>1<sup>st</sup> level</p> <p>2<sup>nd</sup> level</p>	<p>Numeric code of max. 4 digits; 2 protection levels of the programming data: Password “0”, no protection; Password from 1 to 9999, all data are protected</p>		
<p><b>Alarms</b></p> <p>Number of alarms</p> <p>Alarm types Alarm modes</p> <p>Set-point adjustment</p> <p>Hysteresis On-time delay Output status</p> <p>Min. response time</p>	<p>One, independent for every single available variable (see the table “List of the variables that can be...”)</p> <p>Virtual alarm or real alarm Up alarm, down alarm (see the table “List of the variables that can be connected to ...”)</p> <p>From 0 to 100% of the display scale From 0 to full scale 0 to 3600s</p> <p>Selectable; normally de-energized or normally energized ≤ 700ms, set-point on-time delay: “0 s”</p>	<p>String window alarm</p> <p>Other variable alarms</p>	
<p><b>String control</b></p> <p>Function enabling Function selection</p> <p>Function description</p>	<p>Activation: NO/YES Match max. control or median control Match max. control: this function is helpful only if</p>	<p><b>Fuse blow detection</b> (only AV10 range code)</p> <p><b>Wrong PV module connection</b></p>	<p>Warning message transmission through the local port to the VMU-ML unit.</p> <p>Warning message transmission through the local port to the VMUML unit.</p>



## Insulation between inputs and outputs

Module		Any	VMU-ML		VMU-P		VMU-O	VMU-SO		
	Type of input/output	Local bus	DC Power supply	RS485	Temperature: Ch1	Solar irradiation	Relay outputs: Ch1	String input (V-)	String input (A+)	String output (A+)
Any	Local bus	-	0kV	0kV	0kV	0kV	4kV	4kV	4kV	4kV
VMU-ML	DC Power supply	0kV	-	0kV	0kV	0kV	4kV	4kV	4kV	4kV
	RS485	0kV	0kV	-	0kV	0kV	4kV	4kV	4kV	4kV
VMU-P	Temperature: Ch1	0kV	0kV	0kV	-	0kV	4kV	4kV	4kV	4kV
	Solar irradiation	0kV	0kV	0kV	0kV	-	4kV	4kV	4kV	4kV
VMU-O	Relay outputs: Ch1	4kV	4kV	4kV	4kV	4kV	-	4kV	4kV	4kV
VMU-SO	String input (V-)	4kV	4kV	4kV	4kV	4kV	4kV	-	4kV	>5MΩ
	String input (A+)	4kV	4kV	4kV	4kV	4kV	4kV	4kV	-	4kV
	String output (A+)	4kV	4kV	4kV	4kV	4kV	4kV	>5MΩ	4kV	-

0kV	Inputs / outputs are not insulated. Use insulated probes and free of voltage contacts inputs.
4kVrms	EN61010-1, IEC60664-1 - Over-voltage category III, Pollution degree 2, double insulation on systems with max. 300Vrms to ground
4kVrms	IEC60664-1 - Using protection device with clamping voltage $\leq 4kV$ (surge suppressor) the system insulation can be considered as reinforced for string output voltage up to 1000V (800V to earth). IEC60664-1, IEC61730-2 application class B: impulse withstand voltage 1,2/50µsec: 6000V.
4kV	Only if the fuse is not present. Remove the fuse only when the disconnecting breaker is switched off. The fuse is only for over-current protection (it has not to be considered as a disconnecting device).

## General specifications

<b>Operating temperature</b>	See table "String current vs. operating temperature".	Immunity to conducted disturbances	EN61000-4-6: 10V from 150KHz to 80MHz; EN61000-4-5: 500V on power supply; 4kV on string inputs.
<b>Storage temperature</b>	-30 to +70°C (-22°F to 158°F) (R.H. < 90% non-condensing @ 40°C)	Surge	
<b>Over voltage category</b>	Cat. III (IEC 60664, EN60664) For inputs from string: equivalent to Cat. I, reinforced insulation.	<b>EMC (Emission)</b> Radio frequency suppression	According to EN61000-6-3 According to CISPR 22
<b>Insulation (for 1 minute)</b>	See table "Insulation between inputs and outputs"	<b>Standard compliance</b> Safety	IEC60664, IEC61010-1 EN60664, EN61010-1
<b>Dielectric strength</b>	4000 VAC RMS for 1 minute	<b>Approvals</b>	CE, cULus Listed
<b>Noise rejection</b> CMRR	>65 dB, 45 to 65 Hz	<b>Housing</b> Dimensions (WxHxD) Material	17.5 x 90 x 67 mm Noryl, self-extinguishing: UL 94 V-0
<b>EMC (Immunity)</b> Electrostatic discharges	According to EN61000-6-2 EN61000-4-2: 8kV air discharge, 4kV contact;	<b>Mounting</b>	DIN-rail
Immunity to irradiated electromagnetic fields	EN61000-4-3: 10V/m from 80 to 3000MHz;	<b>Protection degree</b> Front Screw terminals	IP40 IP20
Immunity to Burst	EN61000-4-4: 4kV on power supply lines, 2kV on single lines;		

## Connections

<b>VMU-ML</b> Connections Cable cross-section area	Screw-type 1.5 mm <sup>2</sup> max, Min./Max. screws tightening torque: 0.4 Nm / 0.8 Nm	1.5 mm <sup>2</sup>	3 screw terminals: not power input, only for negative voltage signal measurement
Screw terminal purposes 1.5 mm <sup>2</sup>	3 screw terminals used for RS485 communication 2 screw terminals used for power supply	<b>VMU-S0 AV30</b> Connections Cable cross-section area Current (+)	Screw-type Min. 2.5 mm <sup>2</sup> , max 10 mm <sup>2</sup> in case of flexible wire, Max. 16 mm <sup>2</sup> in case of rigid wire. Min./Max. Hole dimension: 7.2x5.1mm, screws tightening torque: 0.5 Nm / 1.1 Nm Max 1.5 mm <sup>2</sup> , Min./Max. screws tightening torque: 0.4 Nm / 0.8 Nm
<b>VMU-S0 AV10</b> Connections Cable cross-section area Current (+)	Screw-type Min. 2.5 mm <sup>2</sup> , max 6 mm <sup>2</sup> in case of flexible wire, Max. 10 mm <sup>2</sup> in case of rigid wire. Min./Max. screws tightening torque: 0.5 Nm / 1.1 Nm	Voltage (-)	1+1 screw terminals: 1 positive for string input and 1 positive for string output (to the Inverter)
Voltage (-)	Max 1.5 mm <sup>2</sup> , Min./Max. screws tightening torque: 0.4 Nm / 0.8 Nm	Screw terminal purposes 16 mm <sup>2</sup>	3 screw terminals: not power input, only for negative voltage signal measurement
Screw terminal purposes 10 mm <sup>2</sup>	1+1 screw terminals: 1 (+) for string input and 1 (+) for string output (to the Inverter)	1.5 mm <sup>2</sup>	
		<b>VMU-P</b> Connections Cable cross-section area	Screw-type 1.5 mm <sup>2</sup> max. Min./Max. screws tightening torque:



## Connections (cont.)

Screw terminal purposes 1.5 mm <sup>2</sup>	0.4 Nm / 0.8 Nm  3 screw terminals used for temperature probe 2 screw terminals used for solar irradiation sensor	Screw terminal purposes 1.5 mm <sup>2</sup>	2 screw terminals: for relay output (SPST type)
<b>VMU-O</b> Connections Cable cross-section area	Screw-type Max 1.5 mm <sup>2</sup> Min./Max. screws tightening torque: 0.4 Nm / 0.8 Nm	<b>Weight</b> (all model)	Approx. 100 g (packing included)

## Power supply specifications

VMU-ML Power supply Power consumption	12 to 28 VDC ≤1W	VMU-S0-P-O Power supply  Power consumption	Self-power supplied through the communication bus ≤0.7W
---	---------------------	---	--

## Sizing of Carlo Gavazzi DC power supply

VMU-S0 units	VMU-O units	VMU-P units	Consumption	Start-up current	Power supply part number
From 1 to 3	None	None	PS <sub>w</sub> : 2.5W <sub>typ</sub>	1.5A for 1s	SPD 24 18 1B or SPM3 24 1
From 1 to 3	Up to 1	Up to 1	PS <sub>w</sub> : 5W <sub>typ</sub>	1.5A for 1s	SPD 24 18 1B or SPM3 24 1
From 4 to 10	From 2 to 4	Up to 1	PS <sub>w</sub> : 11W <sub>typ</sub>	1.5A for 1s	SPD 24 30 1B or SPM3 24 1
From 11 to 14	Up to 1	Up to 1	PS <sub>w</sub> : 10W <sub>typ</sub>	1.5A for 1s	SPD 24 30 1B or SPM3 24 1
Max. 14	Max. 7	Max. 1			

**Note:** the consumption above includes already one VMU-U unit. For different combinations not mentioned above the consumption calculation is the following:  $PS_w < 1W + n_{VMU-S0} * 0.5W + n_{VMU-O} * 0.7W + n_{VMU-P} * 1.8W$ . where "n" is number of power supplied units.

## Variables format

No.	Module	Variable	Data format	Notes
1	VMU-S0	V	0.0 to 1250.0	
2	VMU-S0	A	0.0 to 50.0	
3	VMU-P	Temperature	-60 to 400.0	Temperature (°C/°F). The range is extended to cover both °C and °F indications
4	VMU-P	Solar irradiation (IRR)	0.0 to 9.999	Irradiation kW/m2 (kW/feet2) (e.g. in: 0 to 1kW/m2 (1kW/feet2), out: 0 to 100mV)

## Alarm and diagnostics messages

No.	Message	Notes
1	Conn.CY (AV10 only)	Fuse blow detection.
2	StrinG	String failure warning: the "String control" function has detected a failure.
3	Conn.PY	Reverse string current or voltage
4	SYSteM	Power-up self-test error
5	buS	Auxiliary bus communication error
6	ALArM	Variables alarm (any)

## String current vs. operating temperature

VMU-S AV10 Input current	VMU-O Max. contact current	Other modules	Operating temperature	
10A DC max.	2.5A	VMU-ML, VMU-P	-25 to + 65°C	-13°F to 149°F
12A DC max.	3.0A	VMU-ML, VMU-P	-25 to + 60°C	-13°F to 140°F
14A DC max.	3.5A	VMU-ML, VMU-P	-25 to + 55°C	-13°F to 131°F
15A DC max.	4.0A	VMU-ML, VMU-P	-25 to + 50°C	-13°F to 122°F
16A DC max.	5.0A	VMU-ML, VMU-P	-25 to + 40°C	-13°F to 104°F
VMU-S AV30 Input current				
20A DC max.	2.5A	VMU-ML, VMU-P	-25 to + 65°C	-13°F to 149°F
25A DC max.	3.0A	VMU-ML, VMU-P	-25 to + 60°C	-13°F to 140°F
30A DC max.	3.5A	VMU-ML, VMU-P	-25 to + 55°C	-13°F to 131°F

R.H. < 90% non condensing @ 40°C (104°F)

## List of the variables that can be displayed and connected to ...

- RS485 communication port
- Real and virtual alarms and events

No	Variable	Event-logging	Data-logging	Alarm output	Module (from)	Notes
1	Error: 1	Yes	No	Yes (a)	VMU-ML	Local bus communication problems
2	Error: 2	Yes	No	Yes (a)	VMU-ML	Changed system modules configuration
3	Error: 3	Yes	No	Yes (a)	VMU-ML	Incoherent programming parameters
4	Error: 4	Yes	No	Yes (a)	VMU-ML	More than one VMU-P unit connected to the bus
5	Status: 1	Yes	No	No	VMU-ML	Local programming access
6	Status: 2	Yes	No	No	VMU-ML	Power ON/OFF
7	V	Yes	Yes	Yes	VMU-S0	Available from every string
8	A	Yes	Yes	Yes	VMU-S0	Available from every string
9	Status: 1	Yes	No	Yes	VMU-S0	Incoherent programming parameters
10	Status: 2	Yes	No	Yes	VMU-S0	Fuse blow detection
11	Status: 3	Yes	No	Yes	VMU-S0	Reverse string current or voltage
12	Status: 4	Yes	No	Yes	VMU-S0	High temperature inside VMU-S0 unit
13	String control	Yes	Yes	Yes	VMU-S0	
14	°C (°F) input	Yes	Yes	Yes	VMU-P	PV module temperature
15	kWp/m <sup>2</sup> (kWp/ft <sup>2</sup> )	Yes	Yes	Yes	VMU-P	Solar irradiation
16	Error: 1	Yes	No	Yes	VMU-P	Incoherent programming parameters
17	Error: 2	Yes	No	Yes (c)	VMU-P	Short circuit on probe input
18	Error: 3	Yes	No	Yes (c)	VMU-P	Open circuit on probe input
19	Status: input 1	Yes	No	No	VMU-O	ON /OFF status detection
20	Error: 1	Yes	No	Yes	VMU-O	Incoherent programming parameters

**Note about "Alarm output":** YES (a), YES (b) and YES (c) are according to the relevant letter "OR" logic alarms.

## VMU-ML connections

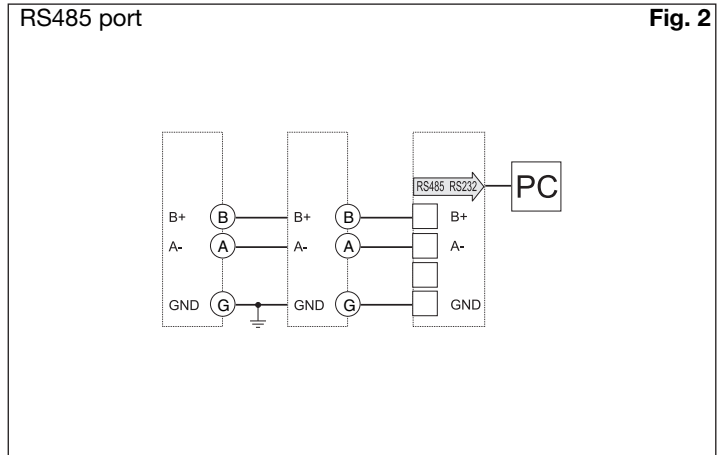
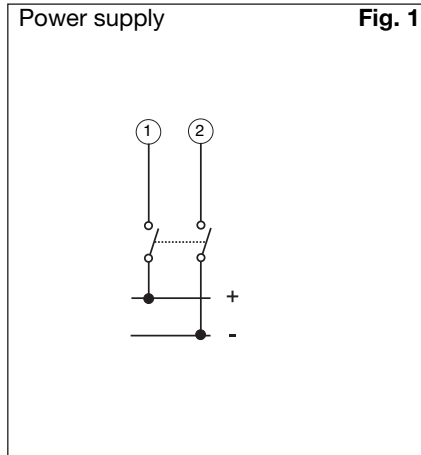
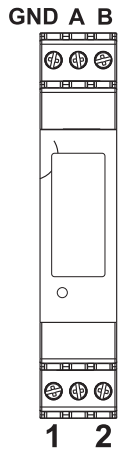

## VMU-S0 (AV10 and AV30) connections

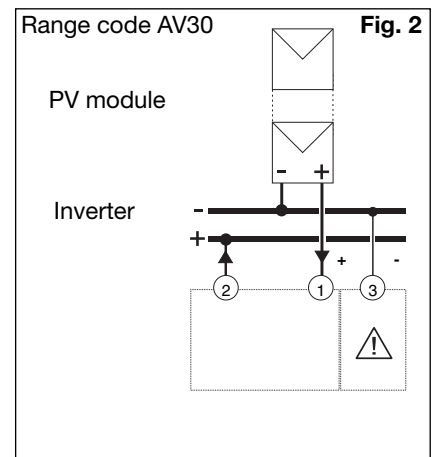
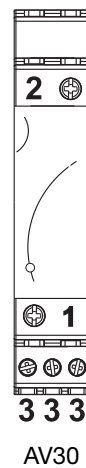
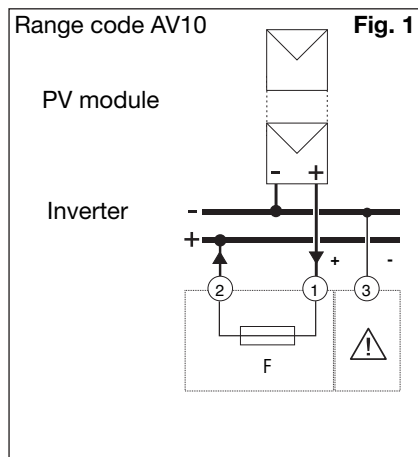
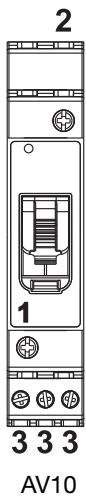

F= 10.3x38mm (IEC269-2-1) 1.25 Isc DC

 = Not power input, only for voltage signal measurement.

## VMU-P (1TI) connections

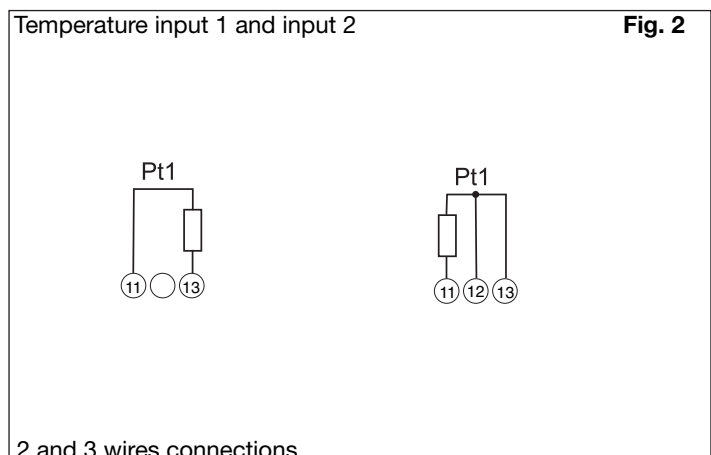
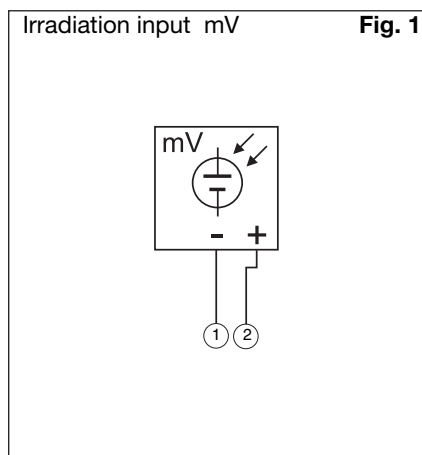
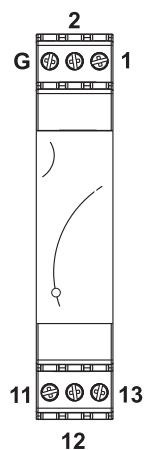

## VMU-P (ITC) connections

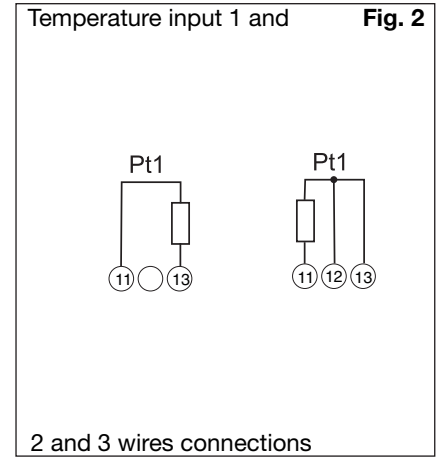
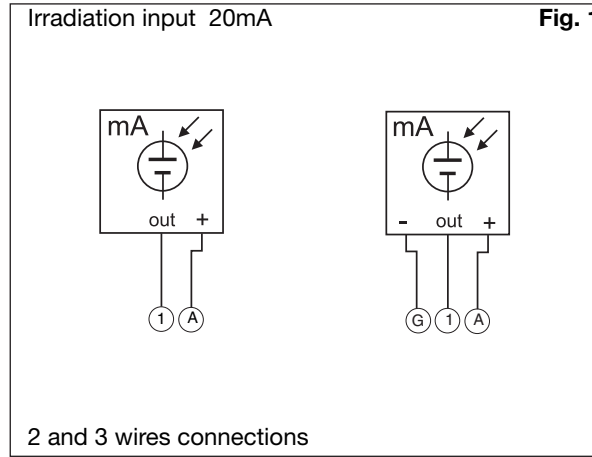
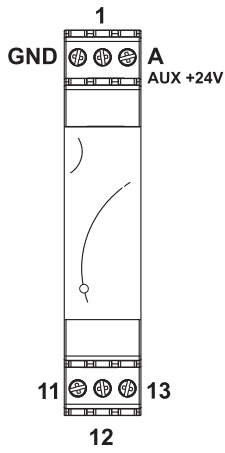

## VMU-O connections

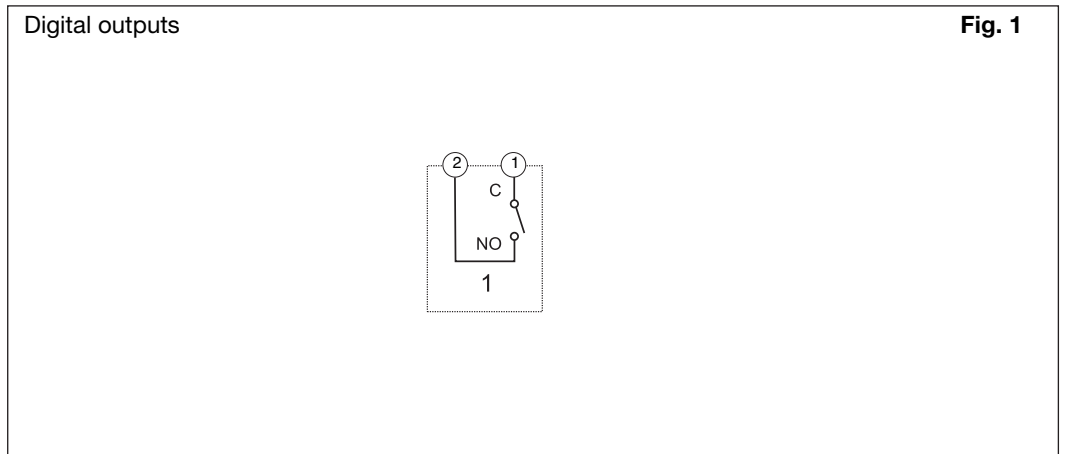
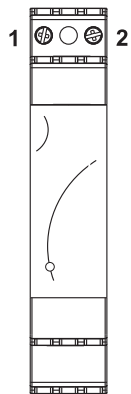

## VMU-1 mounting and positioning

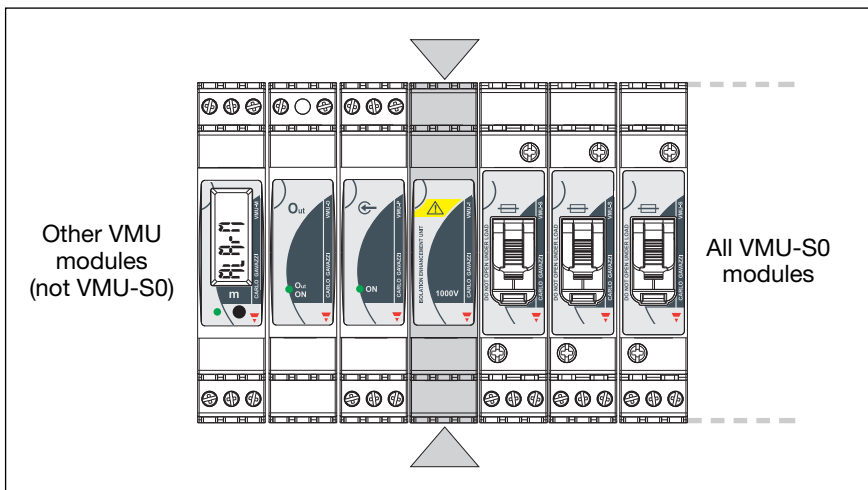

The VMU-1 has to be mounted between the group of VMU-S0 and all the other modules as shown in the example picture on the left.

Every Eos-Array Lite has to be equipped only with one VMU-1.

## VMU-ML Front panel description

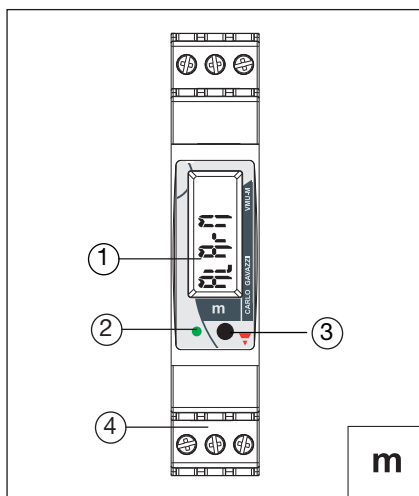

1. **Display.**  
LCD-type with alphanumeric indications to:
  - display some configuration parameters;
  - display some measured variables.
2. **LED.**  
Green steady light: the module is power supplied and there is no communication on the RS485 bus. Green blinking light: the communication on the RS485 bus is working. Red: alarm detected (any). In case of alarm/communication condition the LED alternates its colour from red (alarm) to green. The blinking time is approx. 1 second.
3. **Push button.**  
To program the configuration parameters and to scroll the variables. One key function: short time pushbutton click: variable scroll or parameter increasing. Long time pushbutton click: programming procedure entering, parameter selection confirmation.
4. **Screw terminals.**  
For power supply, bus and digital inputs/output connections

## VMU-S0 Front panel description (AV10 range code: 16A)

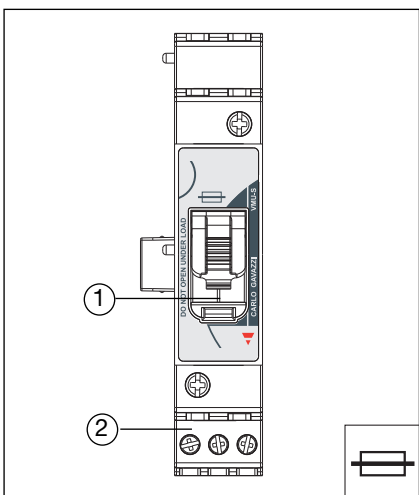

1. **Fuse holder cover**  
For fuse holding and protection.
2. **Screw terminals**  
For string connections

## VMU-S0 Front panel description (AV30 range code: 30A)

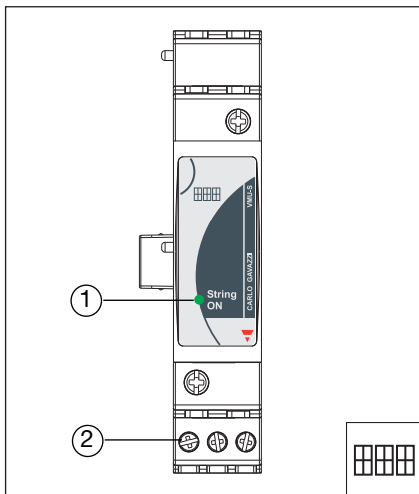

1. **LED**  
Green: the power supply is ON, there is a string current up to 1A;  
Yellow: there is a string current from 1.1 to 6A;  
Light orange: there is a string current from 6.1 to 12A;  
Orange: there is a string current from 12.1 to 16A;  
Dark orange: there is a string current from 16.1 to 20A;  
Red: there is a string current higher than 20A;  
White: the unit is enabled by VMU-M module for data reading and displaying. Cycling from blue to any other colour listed above (from yellow to red): string alarm  
Cycling from blue to violet: inverted string polarity.  
Cycling from white to any other colour: the unit is enabled by VMU-M module for data reading and displaying and shows the status of the module according to the colour list above.
2. **Screw terminals**  
For string connections



## VMU-P Front panel description

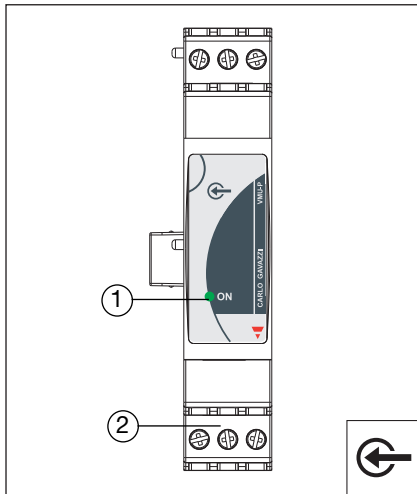

### 1. LED

ON steady light: the module is power supplied.

Green: the power supply is ON.

White: the unit is enabled by VMU-ML module for data reading and displaying

### 2. Screw terminals

For measuring input connections

## VMU-O Front panel description

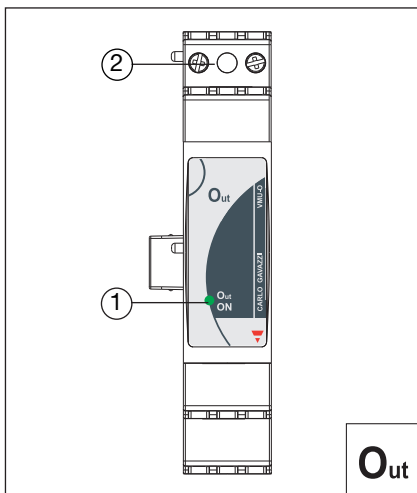

### 1. LED

Green: the power supply is ON

White: the unit is enabled by VMU-ML module for data reading and displaying.

Red: one or both digital inputs are activated

Blue: one or both digital outputs are activated

Cycling from one colour to any other one: the unit shows the status of the module according to the colour list above.

The cycling time is approx. 1 second.

### 2. Screw terminals

For digital inputs and outputs connections

### VMU-ML Dimensions and panel cut-out (mm)

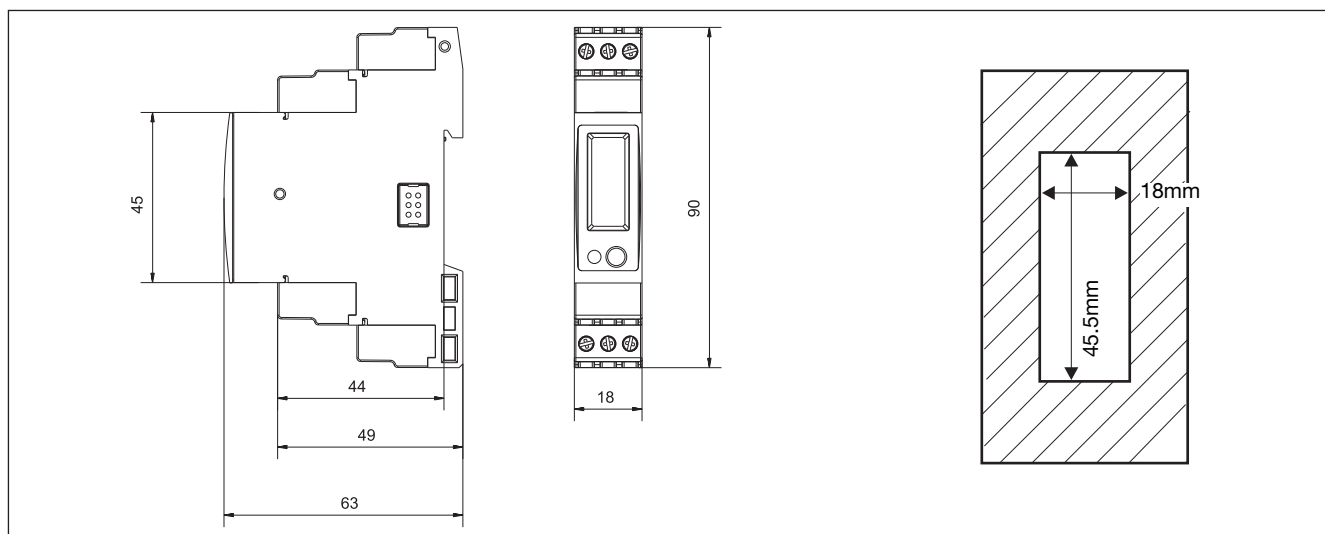

### VMU-S0 (AV10) Dimensions and panel cut-out (mm)

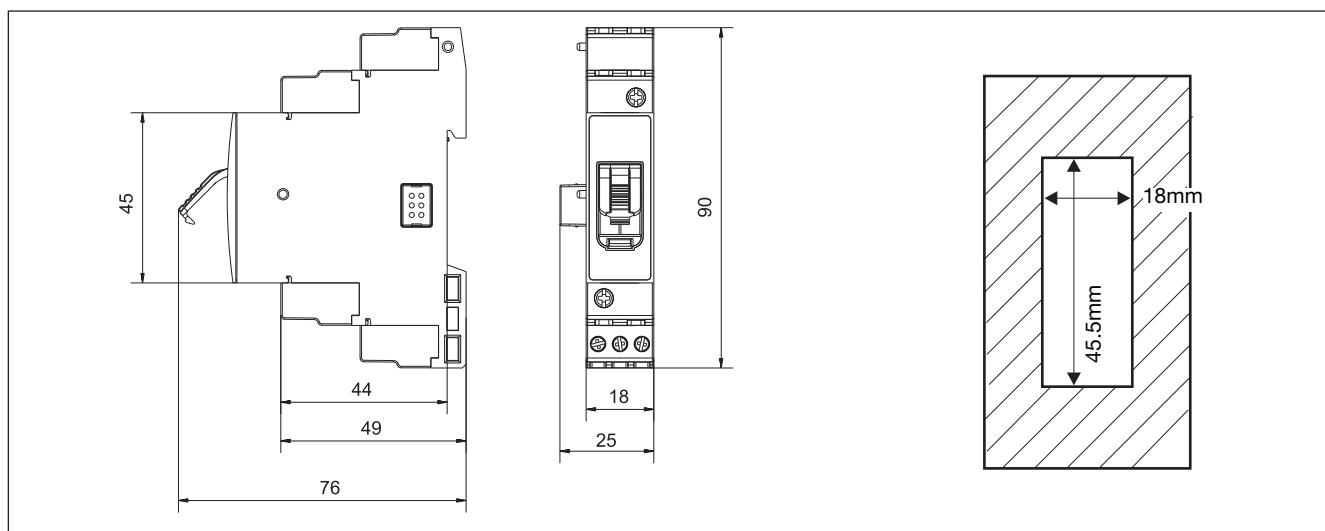

### VMU-S0 (AV30) Dimensions and panel cut-out (mm)

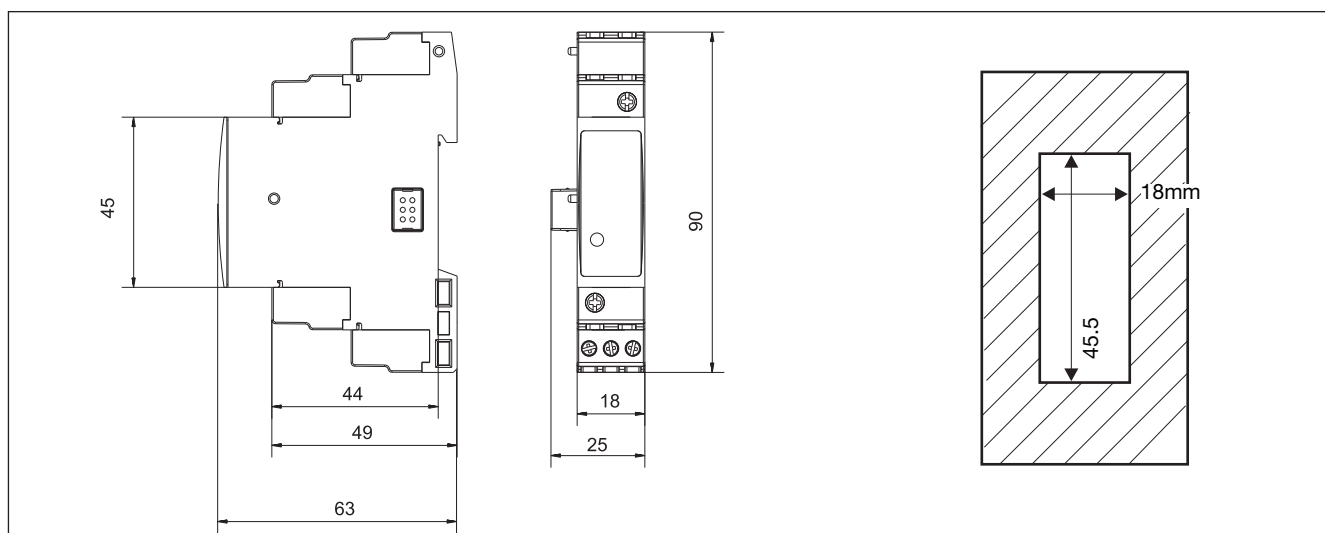

### VMU-1 Dimensions and panel cut-out (mm)

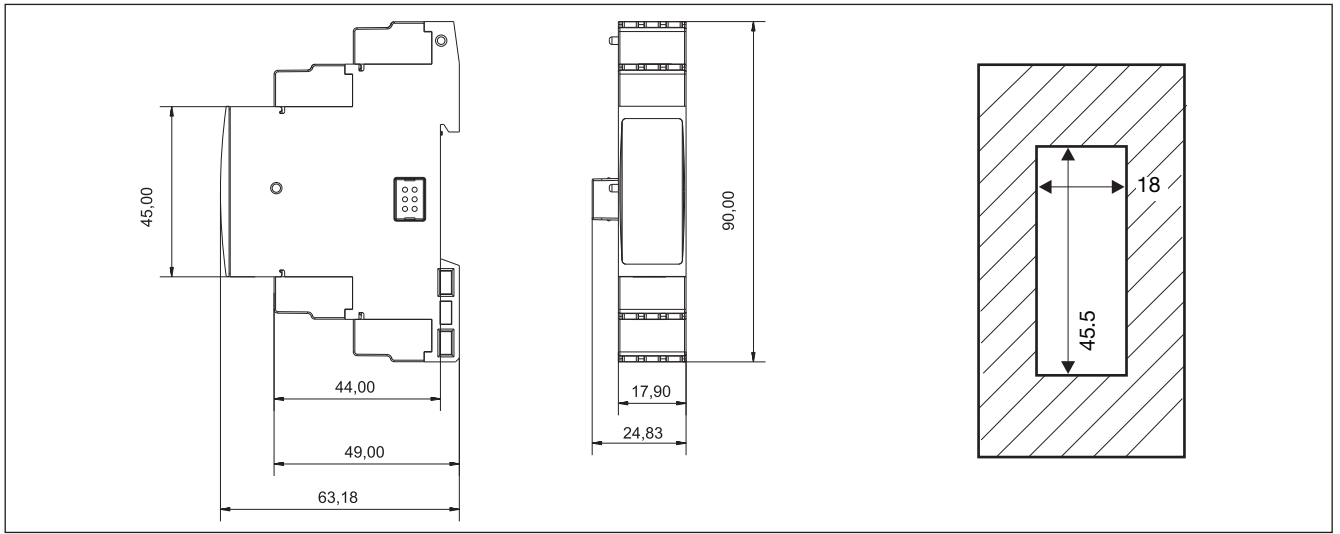

### VMU-P Dimensions and panel cut-out (mm)

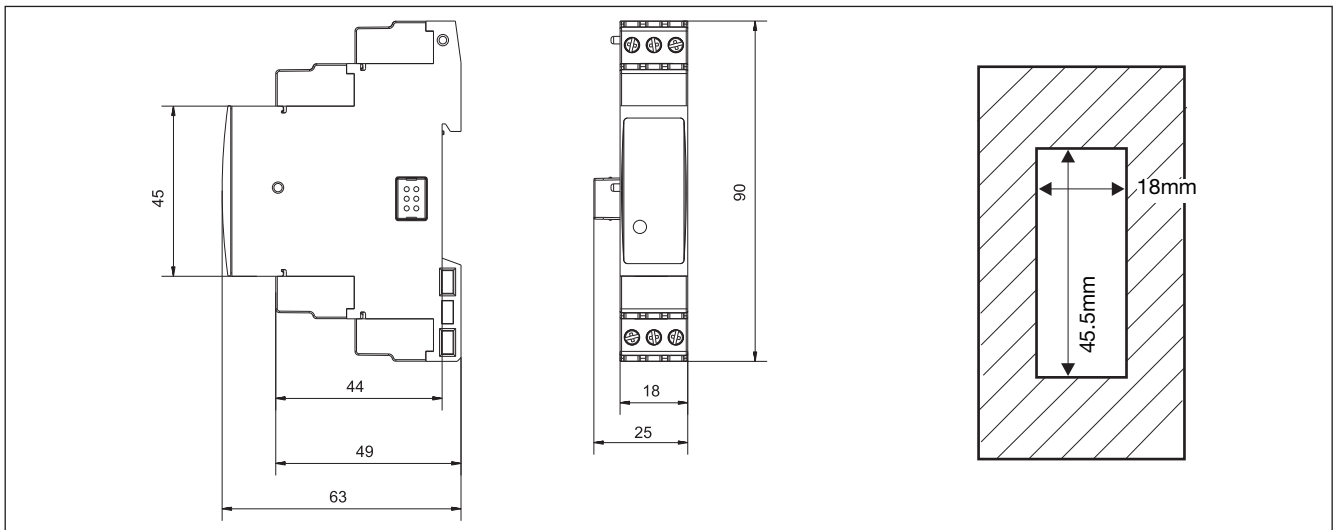

### VMU-O Dimensions and panel cut-out (mm)

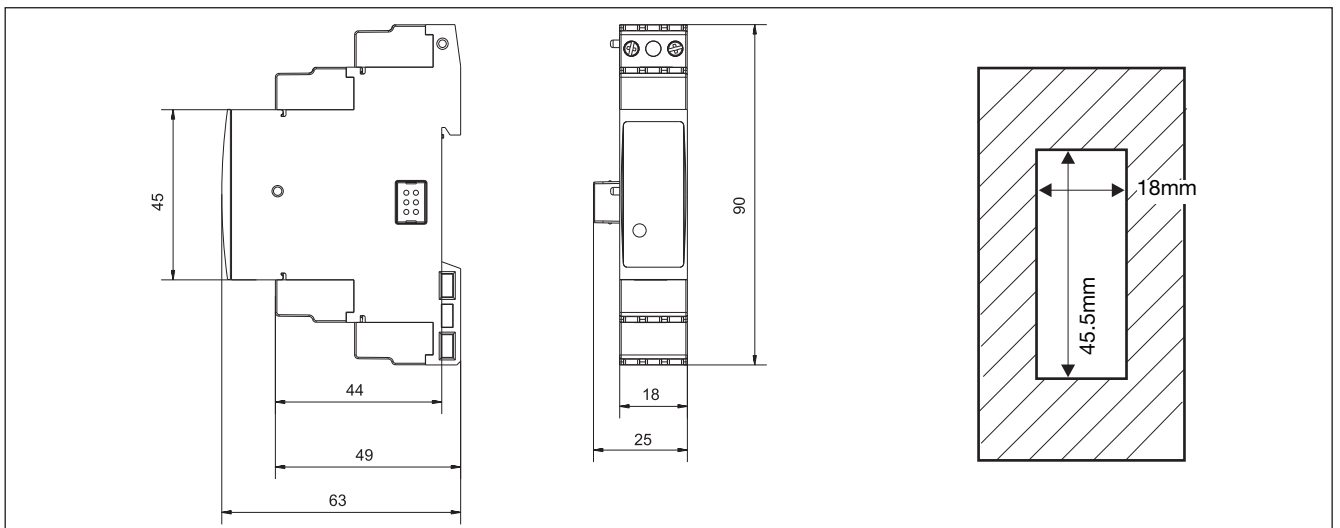



## Mean time to failure (MTTF)

Model	MTTF/MTBF - Years	Test conditions	Standard
VMU-ML	24.2	gf, 50° C	MIL-HDBK-217F
VMU-S0	35.4	gf, 50° C	MIL-HDBK-217F
VMU-P	65.4	gf, 50° C	MIL-HDBK-217F
VMU-O	31.7	gf, 50° C	MIL-HDBK-217F

gf: ground, fixed.

## Eos-ArrayLSoft parameter programming and variable reading software

### Eos-ArrayLSoft

Multi-language software (Italian, English, French, German, Spanish) for variable reading and parameters programming. The program runs under Windows XP/Vista

One / three different applications can be selected:

- Solar: a management of a limited network where Eos-ArrayLSoft manages basically one VMU-ML unit with relevant VMU-S0, VMU-P and VMU-O modules and maybe an energy meter connected to the VMU-ML digital input;
- Solar extended: a management of a complex network where Eos-ArrayLSoft manages many VMU-ML modules and relevant sub networks (VMU-S0, VMU-P and VMU-O units) and maybe an energy meter (EM21-72D, EM24-DIN, EM26-96) connected to the same RS485 bus.

### Configuration mode

There are two configuration levels:

- the RS485 communication network which can include either one or more VMU-ML units;
- the auxiliary network with all the parameters relevant to the following modules: VMU-ML, VMU-S0, VMU-P, VMU-O.

The following matrix are available:

- String 1: V-A
- String 2: V-A
- String n: V-A
- Main: temperature, irradiation and AC energy.
- Plant alarms and errors alarm
- Relay output status.

### Application

### Data displaying

## X-ON Electronics

Largest Supplier of Electrical and Electronic Components

*Click to view similar products for [Industrial Temperature Sensors](#) category:*

*Click to view products by [Carlo Gavazzi](#) manufacturer:*

Other Similar products are found below :

[590-32AC34-103-WRI](#) [590-59CN02-103](#) [A1004SG22P0](#) [HEL-736-U-2-36](#) [G9864ST22F0](#) [HEL-717-U-0-24-00](#) [R-8203](#) [519-39AW09-245](#)  
[519-39CH01-295](#) [521-43BC01-202](#) [535-34AE08-303](#) [512-32AQ01-503](#) [521-33AG04-303](#) [521-53BR01-503](#) [E52P6DY4M](#) [535-34AE09-222](#)  
[590-32AC34-103](#) [590-32AD05-103](#) [3MS1 00211280](#) [E52-P6DY 2M](#) [A1004SX22P0](#) [E52-P20C-N D=8](#) [E52-THE5A 100-200 2M](#) [T200-C32-](#)  
[M14-C](#) [HRTS-5760-B-T-0-18](#) [IOT-9CLT](#) [IOT-9CLT-2](#) [IOT-9CLT-8](#) [LTPCTGA20MBSIBX01](#) [LTPCTFA30MBSITX01](#)  
[LTPCTFA20MBSIDX01](#) [LTPCTAA20MDSIEX01](#) [BB-HS-104T2505402](#) [NCP81255MNTXG](#) [HEL-707-T-1-24-00](#) [HEL-716-U-0-24-00](#) [A-](#)  
[2142](#) [USW2247](#) [R-11614-1](#) [RP103ST22P2](#) [R-10331-3F6](#) [E52-P20AY-D32 4M](#) [89750186](#) [79696038](#) [79696039](#) [A1004AS20T1](#) [JS7352](#) [JI-](#)  
[F103WN-L301](#) [JI-F103WN-L252](#) [JI-103C1R2-L102](#)