

Energy Management Smart Modular Power Analyzer Type WM30 96

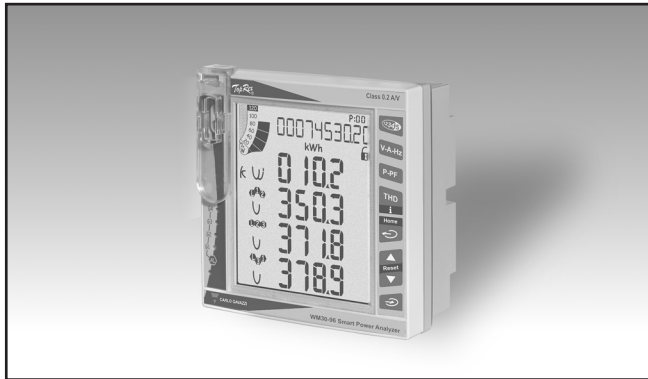

- Communication protocol: MODBUS-RTU
- MODBUS TCP/IP Ethernet port (on request)
- BACnet-IP over Ethernet port (on request)
- BACnet MS/TP over RS485, BTL approved (on request)
- Profibus DP V0 port, PROFIBUS Nutzerorganisation e.V. approved (on request)
- Up to 2 digital outputs (pulse, alarm, remote control) (on request)
- Up to 4 freely configurable virtual alarms
- Up to 2 analogue outputs (+20mA, +10VDC) (on request)

- Class 0.5S (kWh) according to EN62053-22
- Class 2 (kvarh) according to EN62053-23
- Accuracy $\pm 0.2\%$ RDG (current/voltage)
- Instantaneous variables readout: 4x4 DGT
- Energies readout: 9+1 DGT
- System variables: VLL, VLN, A, VA, W, var, PF, Hz, Phase-sequence-asymmetry-loss.
- Single phase variables: VLL, VLN, AL, An (calculated), VA, W, var, PF
- Both system and single phase variables with average and max calculation
- Harmonic analysis (FFT) up to the 32nd harmonic (current and voltage)
- Energy measurements (imported/exported): total and partial kWh and kvarh
- Energy measurements according to ANSI C12.20 CA 0.5, ANSI C12.1
- Run hours counter (8+2 DGT)
- Real time clock function
- Application adaptable display and programming procedure (Easyprog function)
- Universal power supply: 24-48 VDC/AC, 100-240 VDC/AC
- Front dimensions: 96x96 mm
- Front protection degree: IP65, NEMA4X, NEMA12
- One RS232 and RS485 port (on request)

Product Description

Three-phase smart power analyzer with built-in advanced configuration system and LCD data displaying. Particularly recommended for measurement of the main electrical variables. WM30 is based on a modular housing for panel mounting with IP65 (front) protection degree. Moreover, the analyzer can be provided with digital outputs that can be

either for pulse proportional to active and reactive energy being measured or/and for alarm outputs. The instrument can be equipped with the following modules: RS485/RS232, Ethernet, BACnet-IP, BACnet MS/TP or Profibus DP V0 communication ports, pulse and alarm outputs. Parameters programming and data reading can be easily performed by means of UCS (Universal Configuration Software).

How to order **WM30-96 AV5 3 H R2 A2 S1 XX**

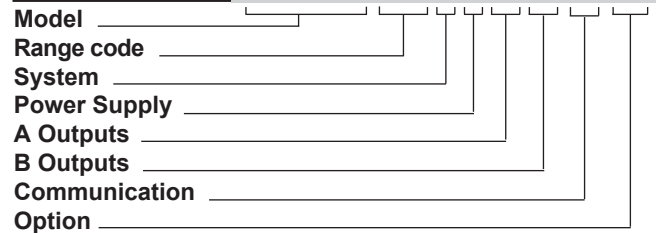

Type Selection

Range codes	System	Power supply	A Outputs
AV4: 3x220(380)...3x400(690)V 1(2)A V _{LN} : 220 to 400 V _{LN} V _{LL} : 380 to 690 V _{LL}	3: balanced and unbalanced load: 3-phase, 4-wire; 3-phase, 3-wire; 2-phase, 3-wire; 1-phase, 2-wire	H: 100-240 +/-10% (90 to 255) VDC/AC (50/60 Hz) L: 24-48 +/-15% (20 to 55) VDC/AC (50/60 Hz)	XX: none O2: Dual channel static output R2: Dual channel relay output
AV5: 3x220(380)...3x400(690)V 5(6)A V _{LN} : 220 to 400 V _{LN} V _{LL} : 380 to 690 V _{LL}			
AV6: 3x57.7(100)...3x133(230)V 5(6)A V _{LN} : 57.7 to 133 V _{LN} V _{LL} : 100 to 230 V _{LL}			
AV7: 3x57.7(100)...3x133(230)V 1(2)A V _{LN} : 57.7 to 133 V _{LN} V _{LL} : 100 to 230 V _{LL}			
	Options	Communication	B Outputs
	XX: none	XX: none S1: RS485/RS232 port E2: Ethernet / Internet port B1: BACnet (IP) over Ethernet B3: BACnet (MS/TP) over RS485 P1: Profibus DP/V0 port	XX: none A2: Dual channel 20mA DC output V2: Dual channel 10V DC output

Position of modules and combination

Ref	Description	Main features	Part number	Pos. A	Pos. B	Pos. C
1	WM30 base provided with display, power supply, measuring inputs	• Inputs/system: AV5.3 • Power supply: H	WM30 AV5 3 H			
2		• Inputs/system: AV6.3 • Power supply: H	WM30 AV6 3 H			
3		• Inputs/system: AV4.3 • Power supply: H	WM30 AV4 3 H			
4		• Inputs/system: AV7.3 • Power supply: H	WM30 AV7 3 H			
		• Inputs/system: AV5.3 • Power supply: L	WM30 AV5 3 L			
		• Inputs/system: AV6.3 • Power supply: L	WM30 AV6 3 L			
		• Inputs/system: AV4.3 • Power supply: L	WM30 AV4 3 L			
		• Inputs/system: AV7.3 • Power supply: L	WM30 AV7 3 L			
5	Dual relay output (SPDT)	• 2-channel • Alarm or/and pulse output	M O R2	X		
6	Dual static output (AC/DC Opto-Mos)	• 2-channel • Alarm or/and pulse output	M O O2	X		
7	Dual analogue output (+20mADC)	• 2-channel	M O A2		X	
8	Dual analogue output (+10VDC)	• 2-channel	M O V2		X	
9	RS485 / RS232 port module	• Max. 115.2 Kbps	M C 485 232			X
10	Ethernet port module	• RJ45 10/100 BaseT	M C ETH			X
11	BACnet-IP port module	• Based on Ethernet bus	M C BAC IP			X
12	BACnet-MS/TP port module	• Over RS485	M C BAC MS			X
13	Profibus module	• Profibus DP V0 • Over RS485	M C P B			X

NOTE:

The position of the modules shall respect the sequence A-B-C. Possible arrangements are M, M-A, M-B, M-C, M-A-B, M-A-C, M-B-C and M-A-B-C where "M" is the basic module (WM30-96).

It is possible to use the WM30-96 without any additional module as a simple indicator.

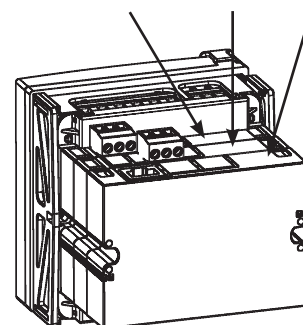

Input specifications

Rated inputs	System type: 1, 2 or 3-phase	Start up current AV5, AV6 Start up current AV4, AV7	5mA 1mA
Input type	Galvanic insulation by means of built-in CT's	Energy additional errors	According to EN62053-22, ANSI C12.20,
Current range (by CT)	AV5 and AV6: 5(6)A AV4 and AV7: 1(2)A	Influence quantities	According to EN62053-23, ANSI C12.1
Voltage (by direct connection or VT/PT)	AV4, AV5: 3x220(380)...3x400(690)V AV6, AV7: 3x57.7(100)...3x133(230)V	Total Harmonic Distortion (THD)	±1% FS (FS: 100%) AV4: Imin: 5mARMS; Imax: 3A; Umin: 30VRMS; Umax: 679Vp AV5: Imin: 5mARMS; Imax: 15Ap; Umin: 30VRMS; Umax: 679Vp AV6: Imin: 5mARMS; Imax: 15Ap; Umin: 30VRMS; Umax: 204Vp AV7: Imin: 5mARMS; Imax: 3A; Umin: 30VRMS; Umax: 204Vp
Accuracy (Display + RS485) (@23°C ±2°C,	0.01In=0.05A (AV5, AV6 - kWh, PF=1) 0.01In=0.01A (AV4, AV7 - kWh, PF=1) 0.05In=0.25A (AV5, AV6 - kWh, PF=1) 0.05In=0.05A (AV4, AV7 - kWh, PF=1)	Temperature drift	≤200ppm/°C
AV4 model	In: see below, Un: see below In: 1A, Imax: 2A; Un: 220 to 400VLN (380 to 690VLL)	Sampling rate	3200 samples/s @ 50Hz, 3840 samples/s @ 60Hz
AV5 model	In: 5A, Imax: 6A; Un: 220 to 400VLN (380 to 690VLL)	Measurements	See "List of the variables that can be connected to:" TRMS measurements of distorted wave forms.
AV6 model	In: 5A, Imax: 6A; Un: 57.7 to 133VLN (100 to 230VLL)	Method	By means of CT's
AV7 model	In: 1A, Imax: 2A; Un: 57.7 to 133VLN (100 to 230VLL)	Coupling type	
Current AV4, AV5, AV6, AV7 models	From 0.01In to 0.05In: ±(0.5% RDG +2DGT) From 0.05In to Imax: ±(0.2% RDG +2DGT)	Crest factor	AV5, AV6: ≤3 (15A max. peak) AV4, AV7: ≤3 (3A max. peak)
Phase-neutral voltage	In the range Un: ±(0,2% RDG +1DGT)	Current Overloads	Continuous (AV5 and AV6) Continuous (AV4 and AV7) For 500ms (AV5 and AV6) For 500ms (AV4 and AV7)
Phase-phase voltage	In the range Un: ±(0.5% RDG +1DGT)	Voltage Overloads	Continuous For 500ms
Voltage tolerance	Un -20%, Un +15%	Input impedance	400VL-L (AV4 and AV5) 208VL-L (AV6 and AV7) 5(6)A (AV5 and AV6) 1(2)A (AV4 and AV7)
Frequency	From 40 to 65 Hz ±(0.02% RDG + 1 DGT), From 65 to 340 Hz ±(0.05% RDG + 1 DGT). From 340 to 440 Hz ±(0.1% RDG + 1 DGT)	Frequency	40 to 440 Hz
Active and Apparent power	From 0.01In to 0.05In, PF 1: ±(1%RDG+1DGT) From 0.05In to Imax PF 0.5L, PF1, PF0.8C: ±(0.5%RDG+1DGT)		
Power Factor	±[0.001+0.5% (1.000 - "PF RDG")]		
Reactive power	From 0.02In to 0.05In, senφ 1: ±(1.5%RDG+1DGT) From 0.05In to Imax, senφ 1: ±(1%RDG+1DGT) From 0.05In to 0.1In, senφ 0.5L/C: ±(1.5%RDG+1DGT) From 0.1In to Imax, senφ 0.5L/C: ±(1%RDG+1DGT)		
Active energy	Class 0.5S according to EN62053-22, ANSI C12.20		
Reactive energy	Class 2 according to EN62053-23, ANSI C12.1.		

Output specifications

Relay outputs (M O R2)			
Physical outputs	2 (max. 1 module per instrument)	Pulse type	Programmable from 0.001 to 10.00 kWh/kvarh per pulse. The above listed variables can be connected to any output.
Purpose	For either alarm output or pulse output	Pulse duration	30 ms (ON), ≥ 30 ms (OFF), according to EN62053-31
Type	Relay, SPDT type	Remote controlled outputs	The activation of the outputs is managed through the serial communication port
Configuration	AC 1-5A @ 250VAC; AC 15-1.5A @ 250VAC	Insulation	See "Insulation between inputs and outputs" table
Function	By means of the front keypad or UCS software		
Function	The outputs can work as alarm outputs but also as pulse outputs, remote controlled outputs, or in any other combination.	20mA analogue outputs (M O A2)	
Alarms	Up alarm and down alarm linked to the virtual alarms, other details see Virtual alarms	Number of outputs	2 per module (max. 1 module per instrument)
Min. response time	≤ 200 ms, filters excluded. Set-point on-time delay: "0 s".	Accuracy (@ 25°C $\pm 5^\circ$ C, R.H. $\leq 60\%$)	$\pm 0.2\%$ FS
Pulse		Range	0 to 20mA
Signal retransmission	Total: +kWh, -kWh, +kvarh, -kvarh. Partial: +kWh, -kWh, +kvarh, -kvarh.	Configuration	By means of the front keypad or UCS software
Pulse type	Programmable from 0.001 to 10.00 kWh/kvarh per pulse. The above listed variables can be connected to any output.	Signal retransmission	The signal output can be connected to any instantaneous variable available in the table "List of the variables that can be connected to".
Pulse duration	30 ms (ON), ≥ 30 ms (OFF), according to EN62053-31	Scaling factor	Programmable within the whole range of retransmission.
Remote controlled outputs	The activation of the outputs is managed through the serial communication port	Response time	≤ 400 ms typical (filter excluded)
Insulation	See "Insulation between inputs and outputs" table	Ripple	$\leq 1\%$ (according to IEC 60688-1, EN 60688-1)
		Total temperature drift	≤ 500 ppm/ $^\circ$ C
		Load	$\leq 600\Omega$
		Insulation	See "Insulation between inputs and outputs" table
Static outputs (M O O2)		10VDC analogue outputs (M O V2)	
Physical outputs	Opto-Mos type	Number of outputs	2 (max. 1 module per instrument)
Purpose	2 (max. 1 module per instrument)	Accuracy (@ 25°C $\pm 5^\circ$ C, R.H. $\leq 60\%$)	$\pm 0.2\%$ FS
Signal	For either pulse output or alarm output	Range	0 to 10 VDC
Configuration	V_{ON} : 2.5VAC/DC/max.100mA V_{OFF} : 42VDC max.	Configuration	By means of the front keypad or UCS software
Function	By means of the front keypad or UCS software	Signal retransmission	The signal output can be connected to any instantaneous variable available in the table "List of the variables that can be connected to".
Function	The outputs can work as alarm outputs but also as pulse outputs, remote controlled outputs, or in any other combination.	Scaling factor	Programmable within the whole range of retransmission;
Alarms	Up alarm and down alarm linked to the virtual alarms, other details see Virtual alarms	Response time	≤ 400 ms typical (filter excluded)
Min. response time	≤ 200 ms, filters excluded. Set-point on-time delay: "0 s".	Ripple	$\leq 1\%$ (according to IEC 60688, EN 60688)
Pulse		Total temperature drift	≤ 350 ppm/ $^\circ$ C
Signal retransmission	Total: +kWh, -kWh, +kvarh, -kvarh. Partial: +kWh, -kWh, +kvarh, -kvarh.	Load	$\geq 10k\Omega$
		Insulation	See "Insulation between inputs and outputs" table



Output specifications (cont.)

<p>RS485 (on request) Type</p> <p>Connections</p> <p>Addresses</p> <p>Protocol Data (bidirectional) Dynamic (reading only)</p> <p>Static (reading and writing only)</p> <p>Data format</p> <p>Baud-rate</p> <p>Driver input capability</p> <p>Note</p> <p>Insulation</p>	<p>Multidrop, bidirectional (static and dynamic variables) 2-wire Max. distance 1000m, termination directly on the module 247, selectable by means of the front key-pad MODBUS/JBUS (RTU)</p> <p>System and phase variables: see table "List of variables..." All the configuration parameters. 1 start bit, 8 data bit, no/ even/odd parity, 1 stop bit Selectable: 9.6k, 19.2k, 38.4k, 115.2k bit/s 1/5 unit load. Maximum 160 transceivers on the same bus. With the rotary switch (on the back of the basic unit) in lock position the modification of the programming parameters and the reset command by means of the serial communication is not allowed anymore. In this case just the data reading is allowed. See "Insulation between inputs and outputs" table</p>	<p>Ethernet/Internet port (on request) Protocols IP configuration</p> <p>Port Client connections Connections</p> <p>Data (bidirectional) Dynamic (reading only)</p> <p>Static (reading and writing only)</p> <p>Note</p> <p>Insulation</p>	<p>Modbus TCP/IP Static IP / Netmask / Default gateway Selectable (default 502) Max 5 simultaneously RJ45 10/100 BaseTX Max. distance 100m</p> <p>System and phase variables: see table "List of variables..."</p> <p>All the configuration parameters. With the rotary switch (on the back of the basic unit) in lock position the modification of the programming parameters and the reset command by means of the serial communication is not allowed anymore. In this case just the data reading is allowed. See "Insulation between inputs and outputs" table</p>
<p>RS232 port (on request) Type</p> <p>Connections Protocol Data (bidirectional) Dynamic (reading only)</p> <p>Static (reading and writing only)</p> <p>Data format</p> <p>Baud-rate</p> <p>Note</p> <p>Insulation</p>	<p>Bidirectional (static and dynamic variables) 3 wires. Max. distance 15m MODBUS RTU /JBUS</p> <p>System and phase variables: see table "List of variables..." All the configuration parameters 1 start bit, 8 data bit, no/ even/odd parity, 1 stop bit Selectable: 9.6k, 19.2k, 38.4k, 115.2k bit/s With the rotary switch (on the back of the basic unit) in lock position the modification of the programming parameters and the reset command by means of the serial communication is not allowed anymore. In this case just the data reading is allowed. See "Insulation between inputs and outputs" table</p>	<p>BACnet-IP (on request) Protocols</p> <p>BACnet-IP IP configuration</p> <p>Port Device object instance</p> <p>Supported services</p> <p>Supported objects</p> <p>IP configuration</p> <p>Modbus TCP/IP</p> <p>Client connections Connections</p>	<p>BACnet-IP (for measurement reading purpose and to write object description) and Modbus TCP/IP (for measurement reading purpose and for programming parameter purpose)</p> <p>Static IP / Netmask / Default gateway Fixed: BAC0h 0 to 9999 selectable by key-pad 0 to 2^22-2 = 4.194.302, selectable by programming software or by BACnet. "I have", "I am", "Who has", "Who is", "Read (multiple) Property" Type 2 (analogue value, including COV property), Type 5 (binary-value for up to 4 virtual alarm re-transmission) Type 8 (device) Static IP / Netmask / Default gateway See "Ethernet/Internet port" above Modbus only: max 5 simultaneously RJ45 10/100 BaseTX Max. distance 100m</p>



Output specifications (cont.)

<p>Data Dynamic (reading only)</p> <p>Static (reading and writing only)</p> <p>Note</p> <p>Insulation</p>	<p>System and phase variables (BACnet-IP and Modbus): see table "List of variables"</p> <p>All the configuration parameters (Modbus only) With the rotary switch (on the back of the basic unit) in lock position the modification of the programming parameters and the reset command by means of the serial communication is not allowed anymore. In this case just the data reading is allowed. See "Insulation between inputs and outputs" table</p>	<p>Ethernet port Protocol</p> <p>IP configuration</p> <p>Modbus Port Client connections</p> <p>Connections</p> <p>Data Dynamic (reading only)</p> <p>Static (reading and writing only)</p> <p>Note</p> <p>Insulation</p> <p>Approval</p>	<p>Modbus TCP/IP (for programming parameter purpose) Static IP / Netmask / Default gateway Selectable (default 502) Modbus only: max 5 simultaneously RJ45 10/100 BaseTX Max. distance 100m</p> <p>System and phase variables: see table "List of variables..."</p> <p>All the configuration parameters (Modbus only). With the rotary switch (on the back of the basic unit) in lock position the modification of the programming parameters and the reset command by means of the serial communication is not allowed anymore. In this case just the data reading is allowed. See "Insulation between inputs and outputs" table</p> <p>BTL</p>
<p>BACnet MS/TP (on request) Available ports RS485 port Type</p> <p>Connections</p> <p>Device object instance</p> <p>Protocol</p> <p>Supported services</p> <p>Supported objects</p> <p>Data (mono-directional) Dynamic</p> <p>Static</p> <p>Data format</p> <p>Baud-rate</p> <p>Driver input capability</p> <p>MAC addresses</p>	<p>2: RS485 and Ethernet</p> <p>Multidrop, mono-directional (dynamic variables) 2-wire Max. distance 1000m, termination directly on the module</p> <p>0 to 9999 selectable by key-pad 0 to 2²²⁻² = 4.194.302, selectable by programming software or by BACnet.</p> <p>BACnet MS/TP (for measurement reading purpose and to write object description)</p> <p>"I have", "I am", "Who has", "Who is", "Read (multiple) Property"</p> <p>Type 2 (analogue value, including COV property), Type 5 (binary-value for up to 4 virtual alarm re-transmission) Type 8 (device)</p> <p>System and phase variables: see table "List of variables..." Not available</p> <p>1 start bit, 8 data bit, no parity, 1 stop bit Selectable: 9.6k, 19.2k, 38.4k or 76.8k kbit/s 1/5 unit load. Maximum 160 transceivers on the same bus. Selectable: 0 to 127</p>	<p>Profibus (MCPB) Available ports USB Purpose</p> <p>Connector Protocol Data format</p> <p>Baudrate</p> <p>Address Profibus Purpose</p> <p>Modules Selectable:</p> <p>Data format (profiles)</p> <p>Connector</p>	<p>2: USB and Profibus DP V0</p> <p>Programmable parameters setting USB micro B Modbus RTU 1 start bit, 8 data bit, no parity, 1 stop bit autorange depending on the master (max 115200 bps) 1</p> <p>Data reading (12 programmable profiles realtime selectable); remote output control; remote tariff control; output up to 4 bytes, input up to 62 words totalizers : FLOAT or INT32; electrical variables: FLOAT or INT16; status variables : UINT16 RS485 DB9</p>



Output specifications (cont.)

Protocol Baudrate	Profibus DP V0 slave 9.6 k to 12 Mbps (9.6, 19.2, 45.45, 93.75, 187.5, or 500 kbps; 1.5, 3, 6, or 12 Mbps)	Insulation	See "Insulation between inputs and outputs" table PROFIBUS Nutzerorganisation e.V.
Address Note	2-125 (default 126) With the rotary switch (on the back of the basic unit) in lock position the modification of the programming parameters and the reset command by means of the serial communication is not allowed. In this case just the data reading is allowed.	Approval	

Energy meters

Meters			
Total	4 (8+2, 9+1, 10 digit)		Min. -9,999,999,999 kWh/kvarh
Partial	4 (8+2, 9+1, 10 digit)		Max. 9,999,999,999 kWh/kvarh.
Pulse output	Connectable to total and/or partial meters		
Energy meter recording	Storage of total and partial energy meters. Energy meter storage format (EEPROM)	Type	
		Total energy meters	+kWh, +kvarh, -kWh, -kvarh
		Partial energy meters	+kWh, +kvarh, -kWh, -kvarh

Harmonic distortion analysis

Analysis principle	FFT		The same for the other phases: L2, L3.
Harmonic measurement		System	
Current	Up to the 32nd harmonic	The harmonic distortion can be measured in 3-wire or 4-wire systems. Tw: 0.02 sec@50Hz without filter	
Voltage	Up to the 32nd harmonic		
Type of harmonics	THD (VL1 and VL1-N) The same for the other phases: L2, L3. THD (AL1)		

Display, LED's and commands

Display refresh time	≤ 250 ms	Energy consumption kWh pulsating	Red LED (only kWh) 0.001 kWh/kvarh by pulse if the Ct ratio by VT ratio is ≤7 0.01 kWh/kvarh by pulse if the Ct ratio by VT ratio is ≥7.1 ≤70.0 0.1 kWh/kvarh by pulse if the Ct ratio by VT ratio is ≥70.1 ≤700.0 1 kWh/kvarh by pulse if the Ct ratio by VT ratio is ≥700.1 ≤7000 10 kWh/kvarh by pulse if the Ct ratio by VT ratio is ≥7001 ≤70.00k 100 kWh/kvarh by pulse if the Ct ratio by VT ratio is >70.01k Max frequency: 16Hz, according to EN 62052-11
Display	4 lines, 4-DGT, 1 lines, 10-DGT		
Type	LCD, single colour backlight	Back position LEDs On the base On the communication modules	Green as power-on Two LEDs: one for TX (green) and one for RX (amber).
Digit dimensions	4-DGT: h 9.5mm; 10-DGT: h 6.0mm		
Instantaneous variables read-out Energies variables read-out	4-DGT Imported Total/Partial: 8+2DGT, 9+1DGT or 10DGT; Exported Total/Partial: 8+2DGT, 9+1DGT or 10DGT (with "-" sign).		
Run Hours counter	8+2 DGT (99.999.999 hours and 59 minutes max)		
Overload status	EEEE indication when the value being measured is exceeding the "Continuous inputs overload" (maximum measurement capacity)	Key-pad	For variable selection, programming of the instrument working parameters, "dmd", "max", total energy and partial energy Reset
Max. and Min. indication	Max. instantaneous variables: 9999; energies: 9 999 999 999. Min. instantaneous variables: 0.000; energies 0.00		
Front position LEDs Virtual alarms	4 red LED available in case of virtual alarm (AL1-AL2-AL3-AL4). Note: the real alarm is just the activation of the proper static or relay output if the proper module is available.		

Main functions

Password	Numeric code of max. 4 digits; 2 protection levels of the programming data:	System 3-Ph.2 balanced load	3-phase (2-wire), one current and 1-phase (L1) to neutral voltage measurement.
1st level	Password "0", no protection;	System 2-Ph	2-phase (3-wire)
2nd level	Password from 1 to 9999, all data are protected	System 1-Ph	1-phase (2-wire)
System selection		Transformer ratio	
System 3-Ph.n unbalanced load	3-phase (4-wire)	VT (PT)	1.0 to 999.9 / 1000 to 9999.
System 3-Ph. unbalanced load	3-phase (3-wire), three currents and 3-phase to phase voltage measurements, or in case of Aaron connection two currents (with special wiring on screw terminals) and 3-phase to phase voltage measurements.	CT	1.0 to 999.9 / 1000 to 9999 (up to 10kA in case of CT with 1A secondary current and up to 50kA in case of CT with 5A secondary current).
System 3-Ph.1 balanced load	3-phase (3-wire), one current and 3-phase to phase voltage measurements 3-phase (4-wire), one current and 3-phase to neutral voltage measurements.	Maximum CT ratio x VT ratio	9999 x 9999
		Filter	
		Operating range	Selectable from 0 to 100% of the input display scale
		Filtering coefficient	Selectable from 1 to 32
		Filter action	Measurements, analogue signal retransmission, serial communication (fundamental variables: V, A, W and their derived ones).

Main functions (cont.)

Displaying Number of variables	Up to 5 variables per page. See "Front view". 7 different set of variables available (see "Display pages") according to the application being selected. One page is freely programmable as combination of variables.	- all the max and dmd values. - total energies: kWh, kvarh; - partial energies: kWh, kvarh
Backlight	The backlight time is programmable from 0 (always on) to 255 minutes	
Virtual alarms Working condition	In case of basic unit or with the addition of M O R2 or M O O2 digital output modules. Up to 4	
No. of alarms	Up alarm and down alarm.	
Working mode	The alarms can be connected to any instantaneous variable available in the table "List of the variables that can be connected to".	
Controlled variables	From 0 to 100% of the display scale	
Set-point adjustment	From 0 to 100% of the display scale	
Hysteresis	0 to 255s	
On-time delay	≤ 200ms, filters excluded.	
Min. response time	Set-point on-time delay: "0 s".	
Reset	By means of the front keypad. It is possible to reset the following data:	
		Harmonic analysis Up to the 32 nd harmonics on current and voltage
		Clock Functions Time format Date format Battery life
		Universal clock and calendar. Hour: minutes: seconds with selectable 24 hours or 12H AM/PM format. Day-month-year with selectable DD-MM-YY or MM-DD-YY format. 10 years
		Easy programming function The displayed energy is always "imported" with the only exception of "C", "D", "E" and "G" types (see "display pages" table). For those latter selections the energies can be either "imported" or "exported" depending on the current direction.

General specifications

Operating temperature	-25°C to +55°C (-13°F to 131°F) (R.H. from 0 to 90% non-condensing @ 40°C) according to EN62053-21, EN62053-23	Standard compliance Safety	IEC60664, IEC61010-1 EN60664, EN61010-1 EN62052-11.
Storage temperature	-30°C to +70°C (-22°F to 158°F) (R.H. < 90% non-condensing @ 40°C) according to EN62053-21, EN62053-23	Metrology Pulse output	EN62053-22, EN62053-23. IEC62053-31
Installation category	Cat. III (IEC60664, EN60664)	Approvals	Eligible System performance Meter for Go Solar California, CE, cULus "Listed"
Insulation (for 1 minute)	See "Insulation between inputs and outputs" table	Connections Cable cross-section area	Screw-type max. 2.5 mm ² . min./max. screws tightening torque: 0.4 Nm / 0.8 Nm. Suggested screws tightening torque: 0.5 Nm
Dielectric strength	4kVAC RMS for 1 minute		
Noise rejection CMRR	100 dB, 48 to 62 Hz		
EMC Immunity and emissions	According to EN62052-11		

General specifications (cont.)

Housing DIN Dimensions (WxHxD)	Module holder: 96x96x50mm. "A" and "B" type modules: 89.5x63x16mm. "C" type module: 89.5x63x20mm. With 3 modules (A+B+C): 81.7 mm	Mounting	Panel mounting
		Protection degree Front Screw terminals	IP65, NEMA4x, NEMA12 IP20
Max. depth behind the panel	Polycarbonate/ABS/Nylon PA66, self-extinguishing: UL 94 V-0	Weight	Approx. 420 g (packing included)
Material			

Insulation between inputs and outputs

	Power Supply (H o L)	Mesuring inputs	Relay output (MOR2)	Static ouput (MOO2)	Serial port	Ethernet port	Analogue outputs
Power Supply (H o L)	-	4kV	4kV	4kV	4kV	4kV	4kV
Mesuring inputs	4kV	-	4kV	4kV	4kV	4kV	4kV
Relay output (MOR2)	4kV	4kV	2kV	-	4kV	4kV	4kV
Static ouput (MOO2)	4kV	4kV	-	2kV	4kV	4kV	4kV
Serial port	4kV	4kV	4kV	4kV	-	-	4kV
Ethernet port	4kV	4kV	4kV	4kV	-	-	4kV
Analogue outputs	4kV	4kV	4kV	4kV	4kV	4kV	4kV ⁽¹⁾

(1): respect another module 4kV, in the same module 0kV.

-: combination not allowed.

NOTE: all the models have, mandatory, to be connected to external current transformers because the isolation among the current inputs is just functional (100VAC).

List of the variables that can be connected to:

- Communication port (all listed variables)
- Analogue outputs (all variables with the only exclusion of “energies” and “run hour counter”)
- Pulse outputs (only “energies”)
- Alarm outputs (“energies”, “hour counter” and “max” excluded)

No	Variable	1-ph. sys (1P)	2-ph. sys (2P)	3-ph. 3-wire balanced sys (3P.1)	3-ph. 2-wire balanced sys (3P.2)	3-ph. 3-wire unbal. sys (3P)	3-ph. 4-wire unbal. sys (3P.n)	Notes
1	VL-N sys	O	X	X	X	#	X	sys= system= Σ
2	VL1	X	X	X	X	#	X	
3	VL2	O	X	H	H	#	X	(H)=VL1
4	VL3	O	O	H	H	#	X	(H)=VL1
5	VL-L sys	O	#	X	X	X	X	sys= system= Σ
6	VL1-2	#	X	X	P	X	X	(P)=VL1*1.73
7	VL2-3	#	O	X	P	X	X	(P)=VL1*1.73
8	VL3-1	#	O	X	P	X	X	(P)=VL1*1.73
9	Asys	O	X	O	O	X	X	
10	An	#	X	O	O	O	X	
11	AL1	X	X	X	X	X	X	
12	AL2	O	X	K	R	X	X	(R)=AL1
13	AL3	O	O	K	R	X	X	(R)=AL1
14	VA sys	X	X	X	X	X	X	sys= system= Σ
15	VA L1	X	X	X	X	O	X	
16	VA L2	O	X	U	U	O	X	(U)=VAL1
17	VA L3	O	O	U	U	O	X	(U)=VAL1
18	var sys	X	X	X	X	X	X	sys= system= Σ
19	var L1	X	X	X	X	O	X	
20	var L2	O	X	V	V	O	X	(V)=VARL1
21	var L3	O	O	V	V	O	X	(V)=VARL1
22	W sys	X	X	X	X	X	X	sys= system= Σ
23	WL1	X	X	X	X	O	X	
24	WL2	O	X	S	S	O	X	(S)=WL1
25	WL3	O	O	S	S	O	X	(S)=WL1
26	PF sys	X	X	X	X	X	X	sys= system= Σ
27	PF L1	X	X	X	X	O	X	
28	PF L2	O	X	T	T	O	X	(T)=PFL1
29	PF L3	O	O	T	T	O	X	(T)=PFL1
30	Hz	X	X	X	X	X	X	
31	Phase seq.	O	X	X	X	X	X	
32	Asy VLL	O	O	X	O	X	X	Asymmetry
33	Asy VLN	O	X	O	O	O	X	Asymmetry
34	Run Hours	X	X	X	X	X	X	
35	kWh (+)	X	X	X	X	X	X	Total
36	kvarh (+)	X	X	X	X	X	X	Total (1)
37	kWh (+)	X	X	X	X	X	X	Partial
38	kvarh (+)	X	X	X	X	X	X	Partial (1)
39	kWh (-)	X	X	X	X	X	X	Total
40	kvarh (-)	X	X	X	X	X	X	Total (1)
41	kWh (-)	X	X	X	X	X	X	Partial
42	kvarh (-)	X	X	X	X	X	X	Partial (1)
43	A L1 THD	X	X	X	X	X	X	
44	A L2 THD	O	X	F	F	X	X	(F)=AL1THD (F)=AL1THD
45	A L3 THD	O	O	F	F	X	X	
46	V L1 THD	X	X	X	X	O	X	(G)=VL1THD
47	V L2 THD	O	X	X	G	O	X	(G)=VL1THD
48	V L3 THD	O	O	X	G	O	X	
49	V L1-2 THD	X	X	X	#	X	X	
50	V L2-3 THD	O	X	X	#	X	X	
51	V L3-1 THD	O	O	X	#	X	X	

(X) = available; (O) = not available (variable not available); (#) Not available (the relevant page is not displayed)

(1): On 4 quadrants (ind/cap)



Power supply specifications

Auxiliary power supply

H: 100-240 +/-10% (90 to 255) VDC/AC (50/60 Hz);
L: 24-48 +/-15% (20 to 55) VDC/AC (50/60 Hz)

Power consumption

AC: 20 VA;
DC: 10 W

List of selectable applications

	Description	Notes
A	Cost allocation	Imported energy metering (Easy connection)
B	Cost control	Imported and partial energy metering (Easy connection)
C	Complex cost allocation	Imported/exported energy (total and partial)
D	Solar	Imported and exported energy metering with some basic power analyzer function
E	Complex cost and power analysis	Imported/exported energy (total and partial) and power analysis
F	Cost and power quality analysis	Imported energy and power quality analysis (Easy connection)
G	Advanced energy and power analysis for power generation	Complete energy metering and power quality analysis

Display pages

Var Type	No	Line 1 Variable Type	Line 2 Variable Type	Line 3 Variable Type	Line 4 Variable Type	Line 5 Variable Type	Note	Applications						
								A	B	C	D	E	F	G
	0	Home page	Programmable					x	x	x	x	x	x	x
a	1	Total kWh (+)	b, c, d	b, c, d	b, c, d	b, c, d		x	x	x	x	x	x	
a	2	Total kvarh (+)	b, c, d	b, c, d	b, c, d	b, c, d		x	x	x	x	x	x	
a	3	Total kWh (-)	b, c, d	b, c, d	b, c, d	b, c, d				x	x	x	x	
a	4	Total kvarh (-)	b, c, d	b, c, d	b, c, d	b, c, d				x	x	x	x	
a	5	kWh (+) partial	b, c, d	b, c, d	b, c, d	b, c, d			x	x		x	x	
a	6	kvarh (+) part.	b, c, d	b, c, d	b, c, d	b, c, d			x	x		x	x	
a	7	kWh (-) partial	b, c, d	b, c, d	b, c, d	b, c, d				x		x	x	
a	8	kvarh (-) part.	b, c, d	b, c, d	b, c, d	b, c, d				x		x	x	
a	9	Run Hours (99999999.99)	b, c, d	b, c, d	b, c, d	b, c, d				x	x	x	x	
b	10	a/Phase seq.	VLN Σ	VL1	VL2	VL3	(1) (2)				x	x	x	
b	11	a/Phase seq.	VLN Σ	VL1-2	VL2-3	VL3-1	(1) (2)				x	x	x	
b	12	a/Phase seq.	An	AL1	AL2	AL3	(1) (2)				x	x	x	
b	13	a/Phase seq.	Hz	"ASY"	VLL sys (% asy)	VLL sys (% asy)	(1) (2)				x	x	x	
b	14	a/Phase seq.	A Σ	AL1	AL2	AL3	(1) (2)				x	x	x	
c	15	a/Phase seq.	W Σ	WL1	WL2	WL3	(1) (2)				x	x	x	
c	16	a/Phase seq.	var Σ	var L1	var L2	var L3	(1) (2)					x	x	
c	17	a/Phase seq.	PF Σ	PF L1	PF L2	PF L3	(1) (2)					x	x	
c	18	a/Phase seq.	VA Σ	VA L1	VA L2	VA L3	(1) (2)					x	x	
d	19	a/Phase seq.		THD V1	THD V2	THD V3	(1) (2)						x	
d	20	a/Phase seq.		THD V12	THD V23	THD V31	(1) (2)						x	
d	21	a/Phase seq.		THD A1	THD A2	THD A3	(1) (2)						x	

Note: the table refers to system 3P.n.

(1) Also maximum value storage (no EEPROM storage).

(2) Also average (dmd) value (no EEPROM storage).

Additional available information on the display

No	Line 1	Line 2	Line 3	Line 4	Line 5	Note	Applications						
							A	B	C	D	E	F	G
1	Lot n. (text) xxxx	Yr. (text) xx	SYS (text)	x (1/2/3)	1...60 (min) "dmd"		x	x	x	x	x	x	x
2	Conn. xxx.x (3ph.n/3ph/3ph./ 3ph.2/1ph/2ph)	CT.rA (text)	1.0 ... 99.99k	PT.rA (text)	1.0...9999		x	x	x	x	x	x	x
3	LED PULSE (text) kWh	xxxx kWh per pulse					x	x	x	x	x	x	x
4	PULSE out1 (text) kWh/kvarh	xxxx kWh/kvarh per pulse	+/- tot/PAr				x	x	x	x	x	x	x
5	PULSE out2 (text) kWh/kvarh	xxxx kWh/kvarh per pulse	+/- tot/PAr				x	x	x	x	x	x	x
6	Remote out	out1 (text)	on/oFF	Out2 (text)	on/oFF		x	x	x	x	x	x	x
7	Alarm 1 nE/nd	None / out 1 / out 2	Set 1	Set 2	(measurement)					x	x	x	x
8	Alarm 2 nE/nd	None / out 1 / out 2	Set 1	Set 2	(measurement)					x	x	x	x
9	Alarm 3 nE/nd	None / out 1 / out 2	Set 1	Set 2	(measurement)					x	x	x	x
10	Alarm 4 nE/nd	None / out 1 / out 2	Set 1	Set 2	(measurement)					x	x	x	x
11	Analogue 1	Hi:E	0.0 ... 9999	Hi.A	0.0 ... 100.0%					x	x	x	x
12	Analogue 2	Hi:E	0.0 ... 9999	Hi.A	0.0 ... 100.0%					x	x	x	x
13	COM port	None / out 1 / out 2	xxx (address)	bdr (text)	9.6/19.2/ 38.4/115.2		x	x	x	x	x	x	x
14	IP address	XXX	XXX	XXX	XXX		x	x	x	x	x	x	x

Back protection rotary switch

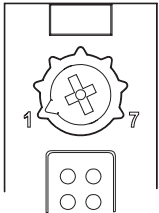
	Function	Rotary switch position	Description
	Unlok	1	All programming parameters are freely modifiable by means of the front key-pad and by means of the communication port.
	Lock	7	The key-pad, as far as programming is concerned and the data through the serial communication cannot be changed (no writing into meter allowed). Data reading is allowed.



Accuracy (According to EN62053-22 and EN62053-23)

kWh, accuracy (RDG) depending on the current

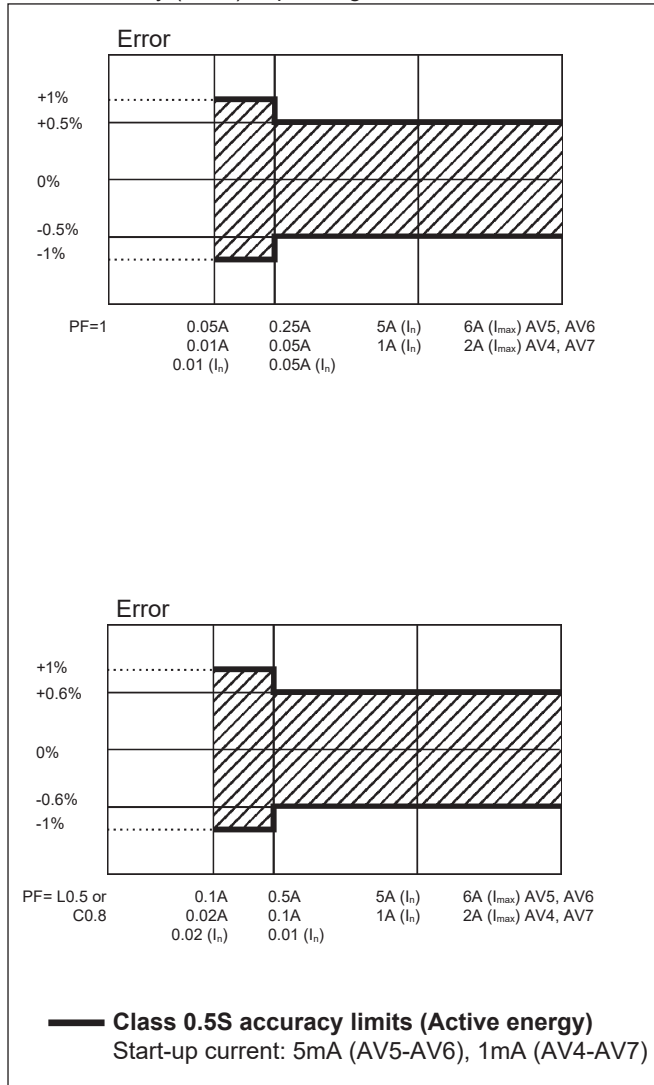

kvarh, accuracy (RDG) depending on the current

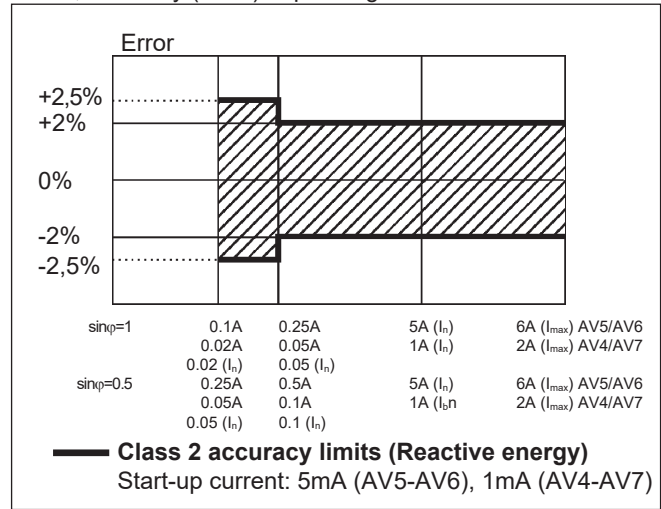

UCS parameter progr. and var. reading software

UCS Software

Multi-language software (Italian, English, French, German, Danish, Czech, Chinese, Spanish) for variable reading, and parameters programming (both online and offline). The program runs under Windows 7 and following versions.

Working mode

Four different working modes can be selected:
 - management of local RS232 (MODBUS);
 - management of local optical port (MODBUS)
 - management of a local RS485 network (MODBUS);
 - managed via TCP port

Used calculation formulas

Phase variables

Instantaneous effective voltage

$$V_{IN} = \sqrt{\frac{1}{n} \cdot \sum_1^n (V_{IN})_i^2}$$

Instantaneous active power

$$W_1 = \frac{1}{n} \cdot \sum_1^n (V_{IN})_i \cdot (A_1)_i$$

Instantaneous power factor

$$\cos\varphi_1 = \frac{W_1}{VA_1}$$

Instantaneous effective current

$$A_1 = \sqrt{\frac{1}{n} \cdot \sum_1^n (A_1)_i^2}$$

Instantaneous apparent power

$$VA_1 = V_{IN} \cdot A_1$$

Instantaneous reactive power

$$\text{var}_1 = \sqrt{(VA_1)^2 - (W_1)^2}$$

System variables

Equivalent three-phase voltage

$$V_{\Sigma} = \frac{V_1 + V_2 + V_3}{3} \cdot \sqrt{3}$$

Voltage asymmetry

$$ASY_{LL} = \frac{(V_{LL\max} - V_{LL\min})}{V_{LL\Sigma}}$$

$$ASY_{LN} = \frac{(V_{LN\max} - V_{LN\min})}{V_{LN\Sigma}}$$

Three-phase reactive power

$$\text{var}_{\Sigma} = (\text{var}_1 + \text{var}_2 + \text{var}_3)$$

Three-phase active power

$$W_{\Sigma} = W_1 + W_2 + W_3$$

Three-phase apparent power

$$VA_{\Sigma} = \sqrt{W_{\Sigma}^2 + \text{var}_{\Sigma}^2}$$

Total harmonic distortion

$$THD_N = 100 \cdot \frac{\sqrt{\sum_{n=2}^N |X_n|^2}}{|X_1|}$$

Three-phase power factor

$$\cos\varphi_{\Sigma} = \frac{W_{\Sigma}}{VA_{\Sigma}} \quad (\text{TPF})$$

Energy metering

$$k \text{ var hi} = \int_{t_1}^{t_2} Qi(t) dt \cong \Delta t \sum_{n1}^{n2} Qnj$$

$$kWhi = \int_{t_1}^{t_2} Pi(t) dt \cong \Delta t \sum_{n1}^{n2} Pnj$$

Where:

i= considered phase (L1, L2 or L3)
P= active power; **Q**= reactive power;
t₁, **t₂**= starting and ending time points of consumption recording; **n**= time unit Δt ; Δt = time interval between two successive power consumptions;
n₁, **n₂**= starting and ending discrete time points of consumption recording

Wiring diagrams

System type selection: 3-Ph.2

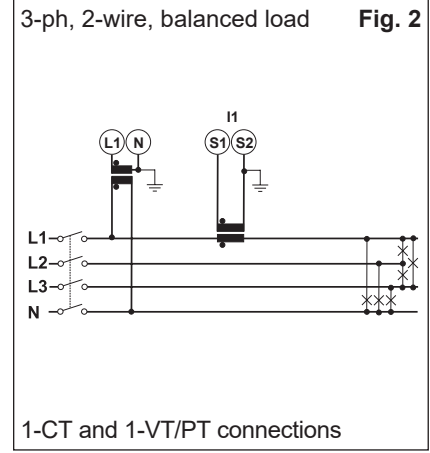
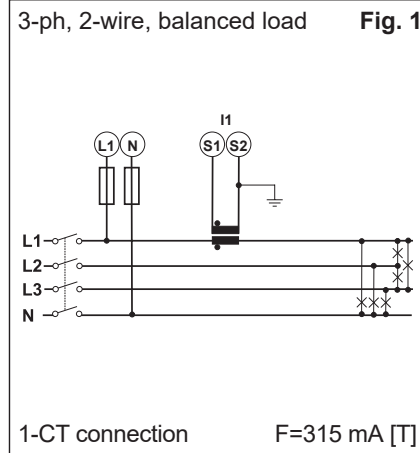
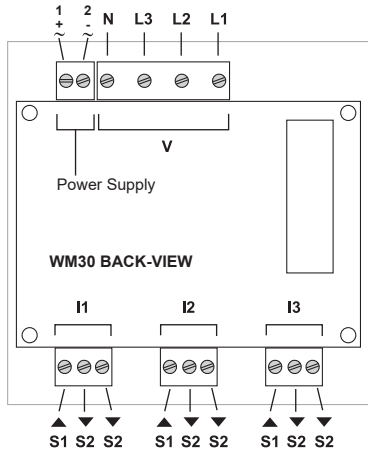

System type selection: 3-Ph.n

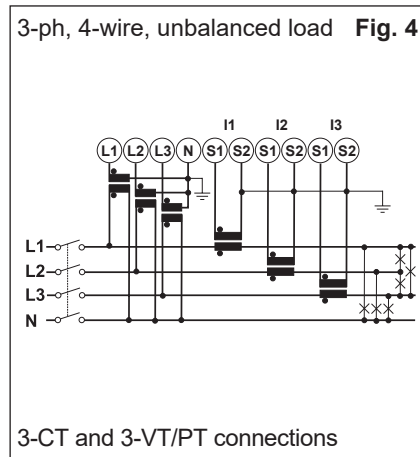
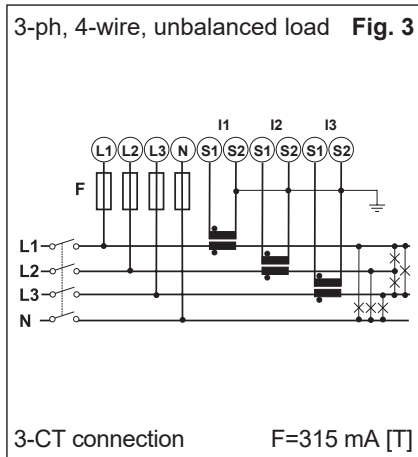

System type selection: 3-Ph

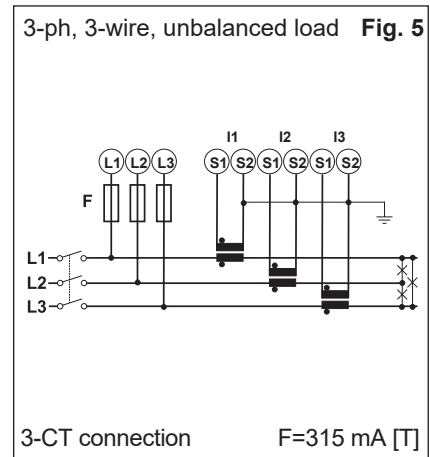

System type selection: 3-Ph (cont.)

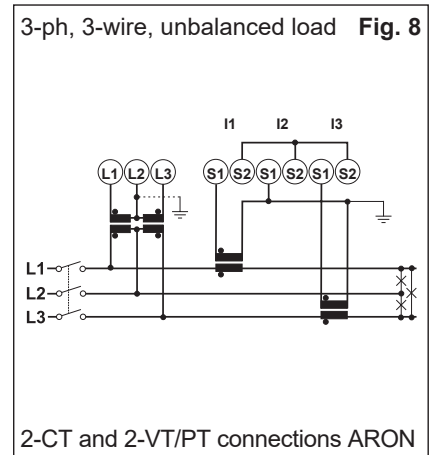
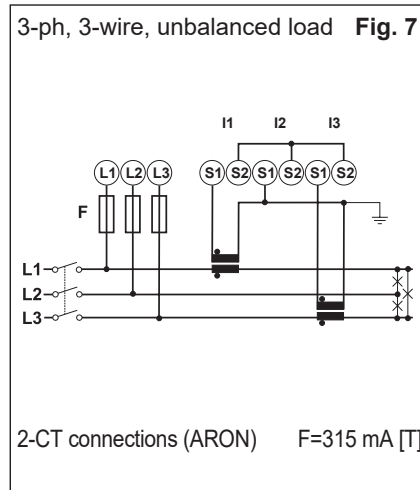
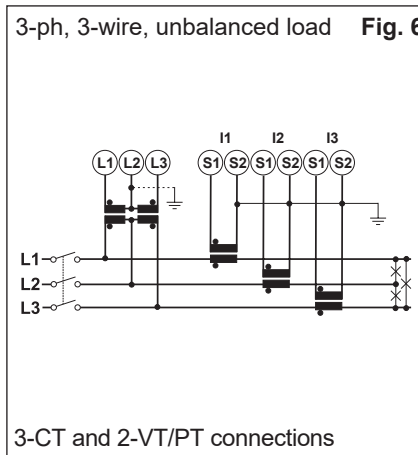

Wiring diagrams

System type selection: 3-Ph.1

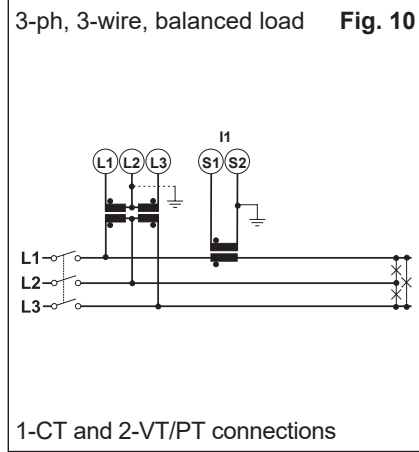
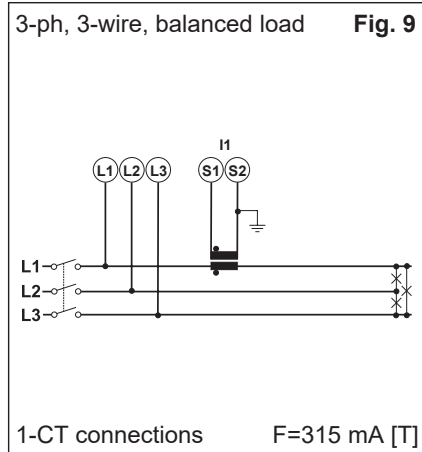

System type selection: 2-Ph

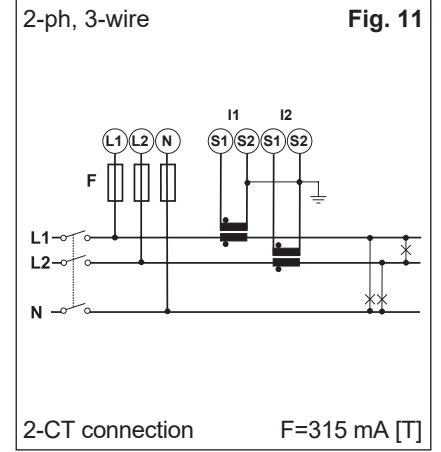

System type selection: 2-Ph (cont.)

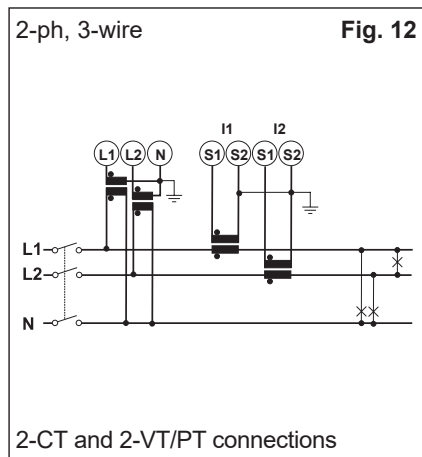

System type selection: 1-Ph

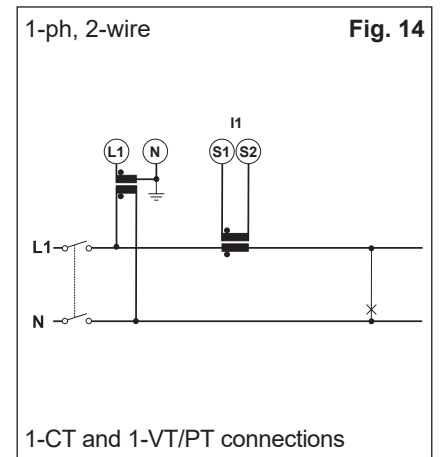
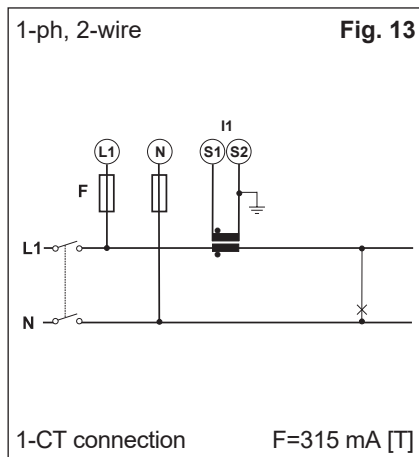

Power Supply

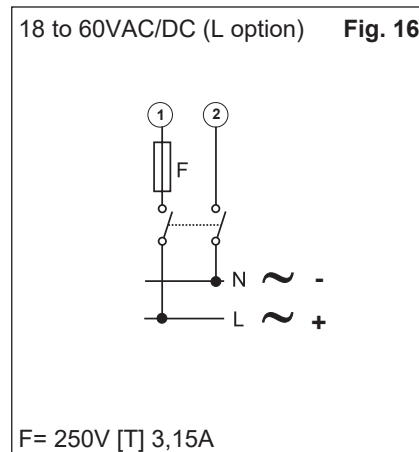
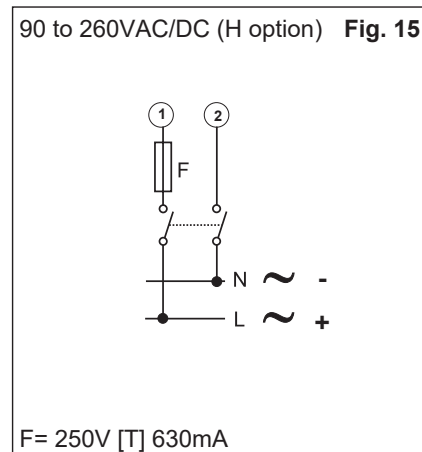

Static, relay and analogue outputs wiring diagrams

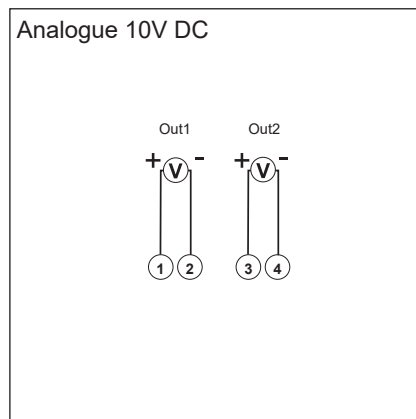
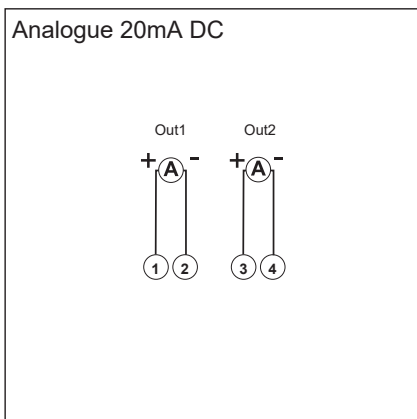
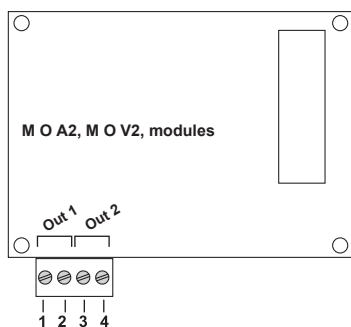
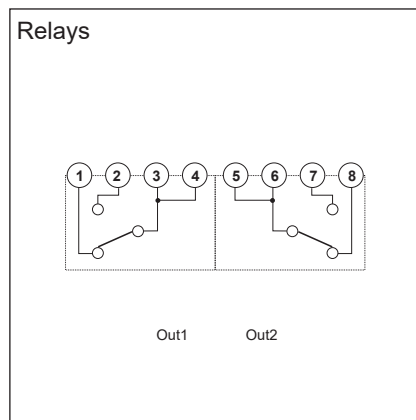
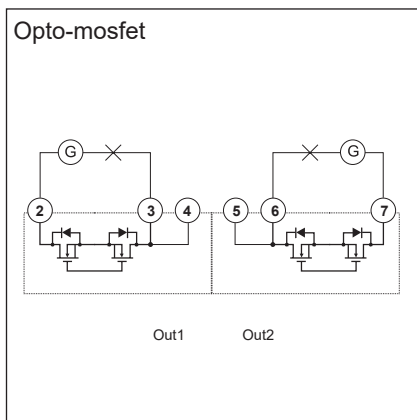
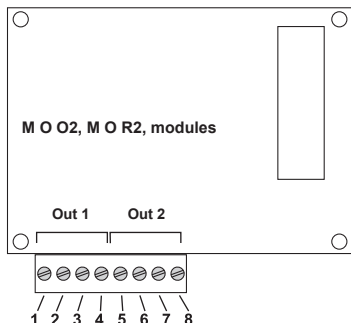

RS485 and RS232 wiring diagrams

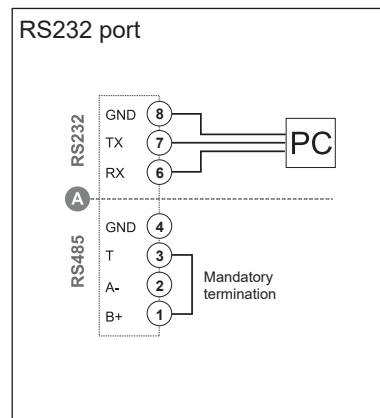
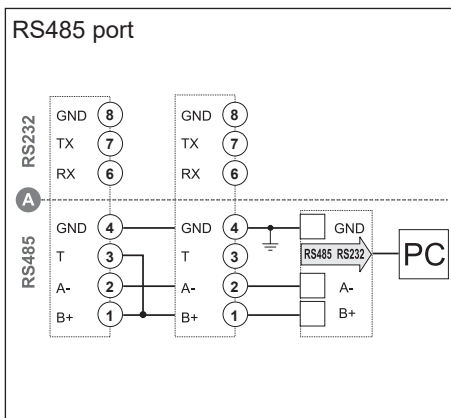
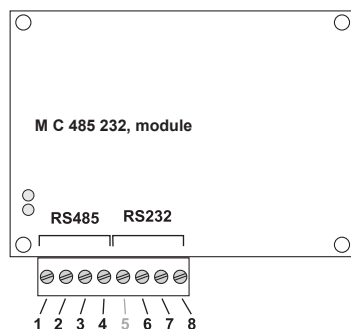

NOTE. RS485: additional devices provided with RS485 are connected in parallel. The termination of the serial output is carried out only on the last instrument of the network, by means of a jumper between (B+) and (T). The communication RS232 and RS485 ports **can't be** connected and used simultaneously.

RS485 wiring diagram of Bacnet module

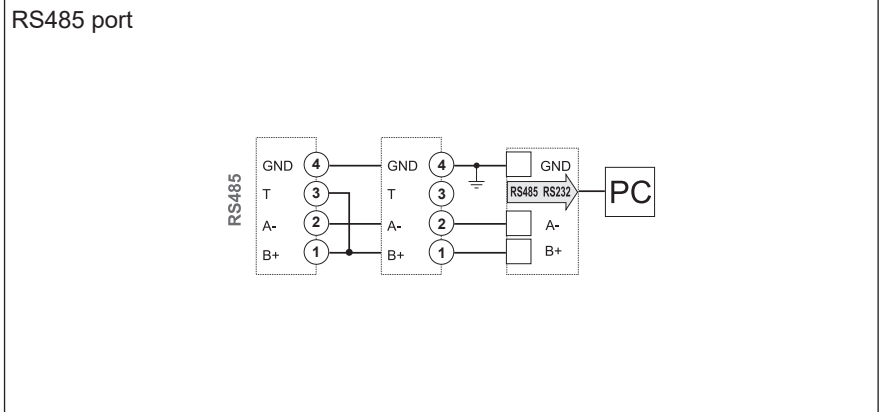
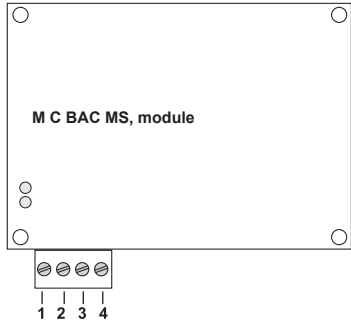

NOTE. RS485: additional devices provided with RS485 are connected in parallel. The termination of the serial output is carried out only on the last instrument of the network, by means of a jumper between (B+) and (T).

Ethernet and BACnet-IP connections

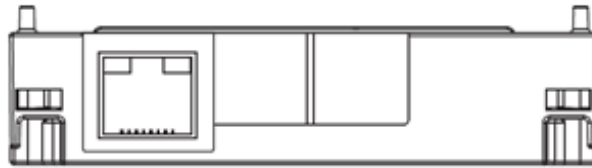

Connection to Ethernet or BACnet modules using the RJ45 connector.

Profibus module connections

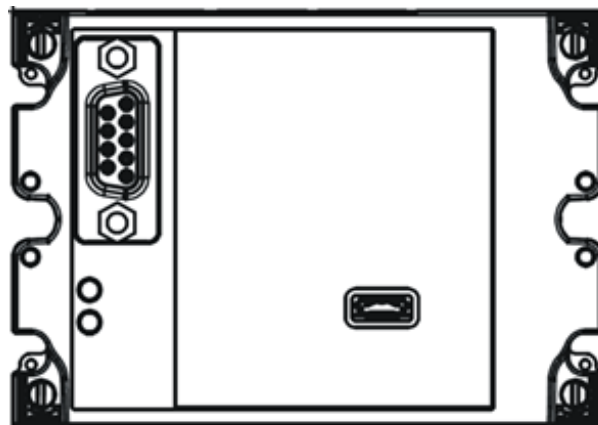

Connection to the Profibus module using USB micro type B (Modbus RTU) and RS485 DB9 (Profibus DP-V0).

Front panel description

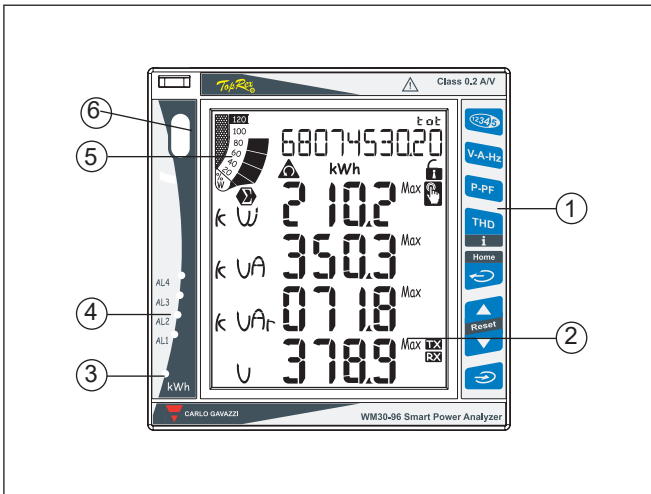

1. **Key-pad**
To program the configuration parameters and scroll the variables on the display.
2. **Display**
LCD-type with alphanumeric indications to:
 - display configuration parameters;
 - display all the measured variables.
3. **kWh LED**
Red LED blinking proportional to the energy being measured
4. **Alarm LED's**
Red LED's light-on when virtual alarms are activated.
5. **Main bar-graph**
To display the power consumption versus the installed power.
6. **Optical communication port**
To program the working parameters and to read the measurements.

Dimensions and Panel cut-out

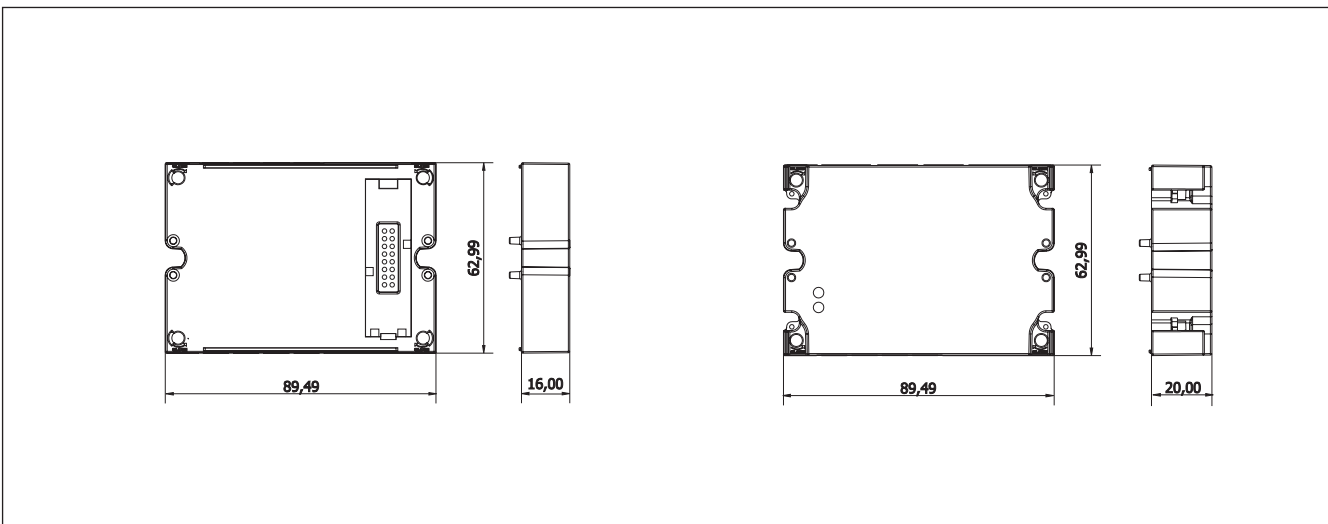
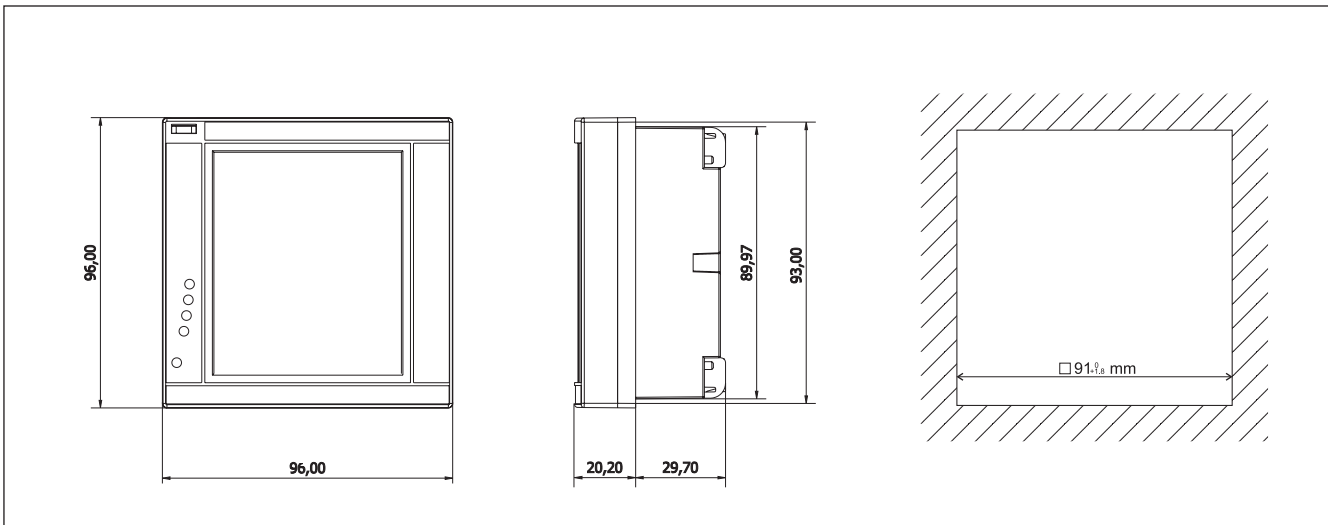

X-ON Electronics

Largest Supplier of Electrical and Electronic Components

Click to view similar products for [Power Analysers](#) category:

Click to view products by [Carlo Gavazzi](#) manufacturer:

Other Similar products are found below :

[AQ1018](#) [AQ1038](#) [AR1039](#) [AD1016H](#) [AD1040](#) [MOA2](#) [MOO2](#) [MOR2](#) [EM2172DAV63XOSX](#) [AQ1042](#) [AD1047](#) [58250-1854](#)
[WM20AV53H](#) [AD2000](#) [AQ2030](#) [AR1060](#) [EM24DINAV93XISX](#) [EM2696AV53HR2S1XX](#) [EM50DINMA53HRSMC](#) [MC485232](#) [MCETH](#)
[MFI6R4](#) [WM1496AV53CX](#) [WM1496AV63CX](#) [WM1496AV63DS](#) [WM30AV53H](#) [WM30AV63H](#) [WM30AV63L](#) [WM40AV53H](#)
[WM50AV53HBC](#) [CS-BB3-04](#) [58250-1852](#) [58250-1853](#) [TOL-18585](#) [WM1596AV53XOSPFB](#) [WM1596AV53XOSX](#)
[WM1596AV53XOXPFB](#) [WM1596AV53XOXX](#) [EM24DINAV53DISX](#) [EM28072DMV53X2SX](#) [EM28072DMV63X2SX](#)
[EM50DINAV53HRSX](#) [EM50DINRG53HRSX](#) [EM50DINMV53HRSX](#) [WM1496AV53HDG](#) [WM14-96AV63CS](#) [58430-1286](#)