

# 承 认 书

## SPECIFICATION FOR APPROVAL

|                          |              |
|--------------------------|--------------|
| 客户名称<br>CUSTOMER         |              |
| 品名<br>DESCRIPTION        | PHB型压接式条形连接器 |
| 料号<br>CUSERTOMER PART NO | A2005        |
| 日期<br>DATE               |              |

客户确认 (APPROVED SIGNATURES)

| 核准 (APPROVAL)  | 工程 (ENGINEERING) | 品管 (QC) |
|--|------------------|---------|
|  |                  |         |
| 承认结果： <input type="checkbox"/> 承认 <input type="checkbox"/> 不承认 <input type="checkbox"/> 重新送样 |                  |         |

| 核准 (APPROVAL) | 确认 (CHECK) | 制作 (PREPARE) |
|---------------|------------|--------------|
|               |            |              |

.....

# 目 录

---

|               |       |
|---------------|-------|
| 1. 封面         | 1     |
| 2. 目录         | 2     |
| 3. 命名和图纸      | 3-17  |
| 4. 规格书        | 18-21 |
| 5. 样件检验/实验报告  | 22-25 |
| 6. 认证         | 26-29 |
| 7. 连接器RoHS报告  | 30-36 |
| 8. 连接器REACH报告 | 37-52 |
| 9. 连接器卤素报告    | 53-64 |
| 10. 贴片RoHS报告  | 65-72 |
| 11. 端子RoHS报告  | 73-77 |
| 12. 端子REACH报告 | 78-86 |
| 12. MSDS      | 87-94 |

---

# PHB料号命名规则

## PHB Part No. Naming Rules

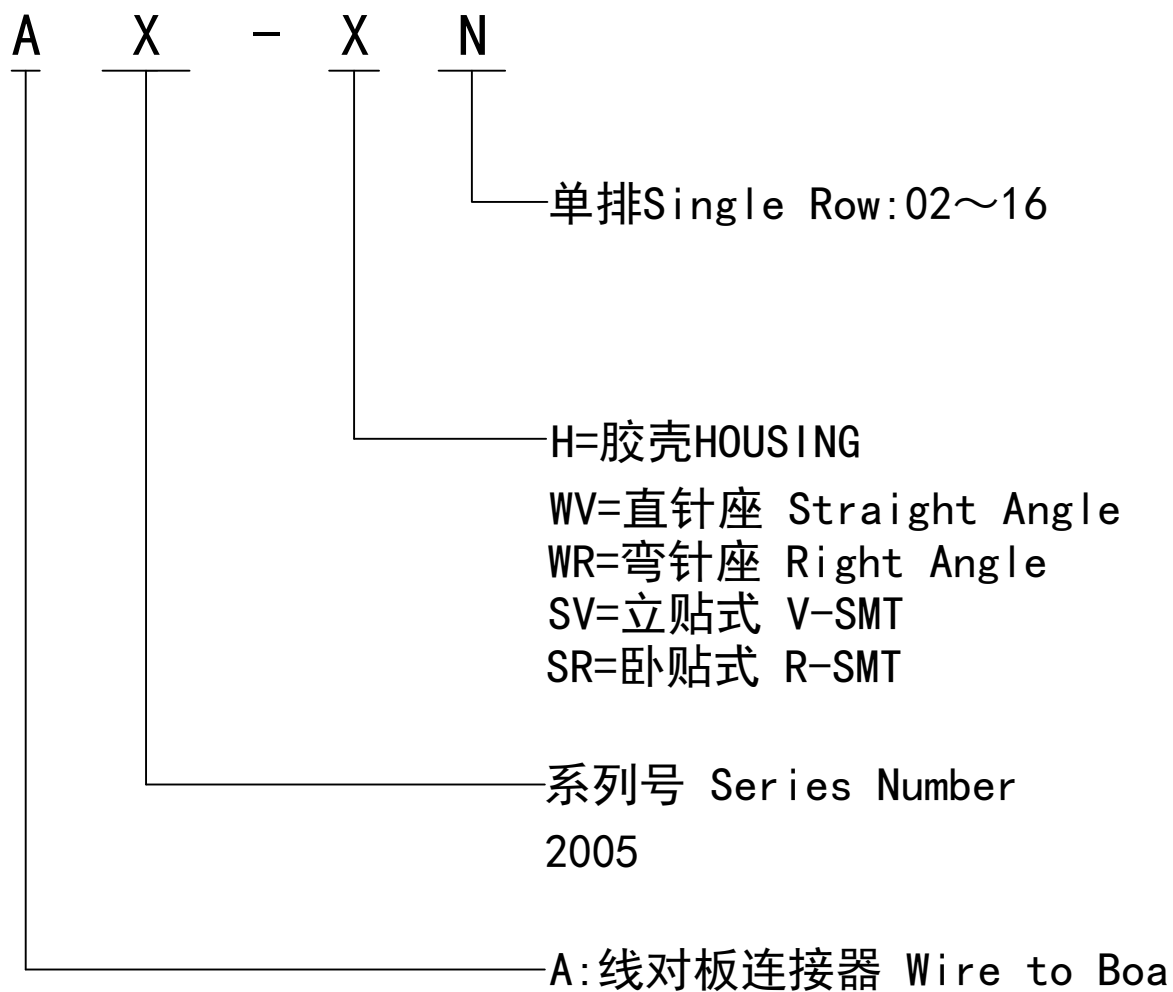

# PHB连接器承认图面

## 安装尺寸 Mounting Measurement

### 立式 Straight Angle (V-Type)

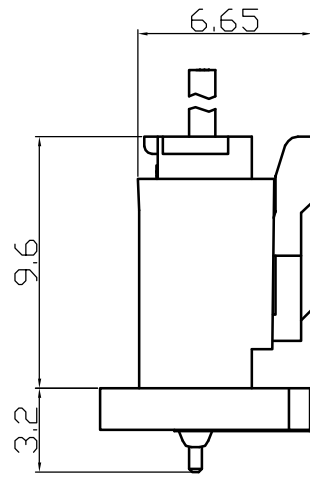

### 卧式 Right Angle (R-Type)

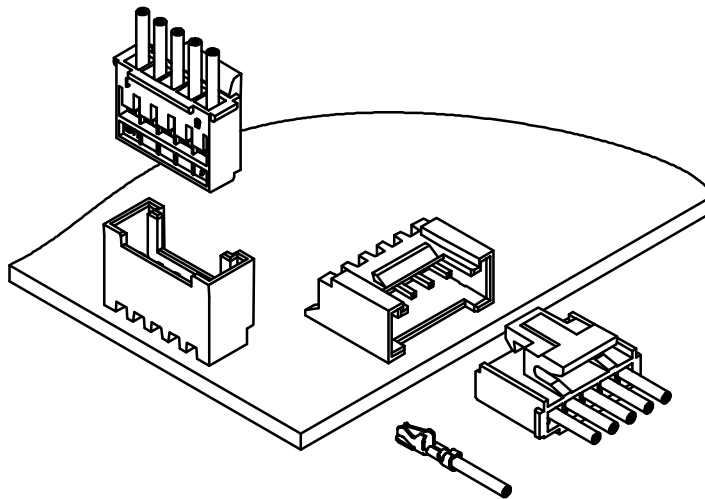
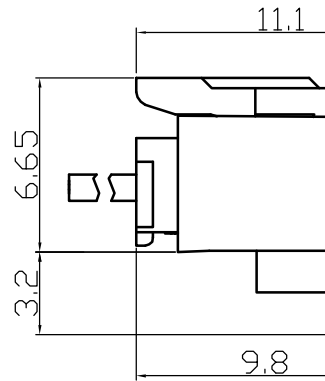

| 序号 图号             |       |        |      |
|-------------------|-------|--------|------|
| 未注公差              |       |        |      |
| X.° ±3° X.X° ±0.1 |       |        |      |
| >0-3              | >3-18 | >18-50 | >50- |
| ±0.12             | ±0.15 | ±0.3   | ±0.  |
| 制作                | 审核    | 批准     |      |

旧底图总号

底图总号

签字

日期

# PHB连接器承认图面

## 安装尺寸 Mounting Measurement

### 立式 Straight Angle(V-Type)

### 卧式 Right Angle(R-Type)

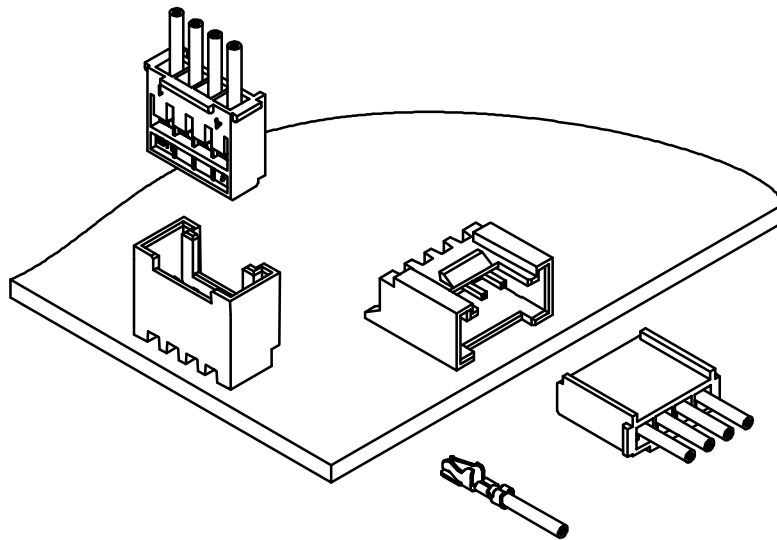
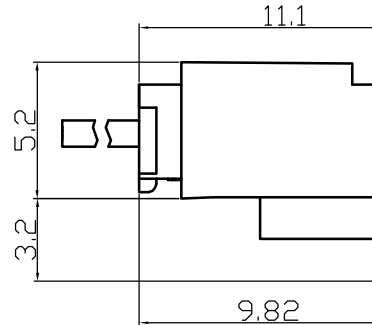
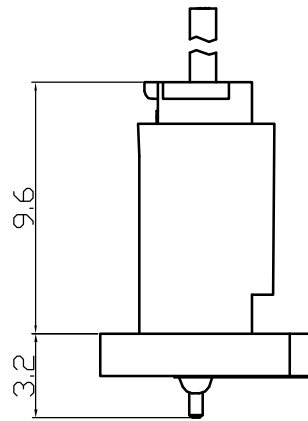

| 序号 图号             |       |        |      |
|-------------------|-------|--------|------|
| 未注公差              |       |        |      |
| X.° ±3° X.X° ±0.1 |       |        |      |
| >0-3              | >3-18 | >18-50 | >50- |
| ±0.12             | ±0.15 | ±0.3   | ±0.  |
| 制作                | 审核    | 批准     |      |

旧底图总号

底图总号

签字

日期

PHB连接器承认图面

安装尺寸 Mounting Measurement

立式 Straight Angle(V-Type)

卧式 Right Angle

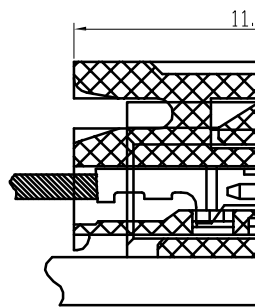
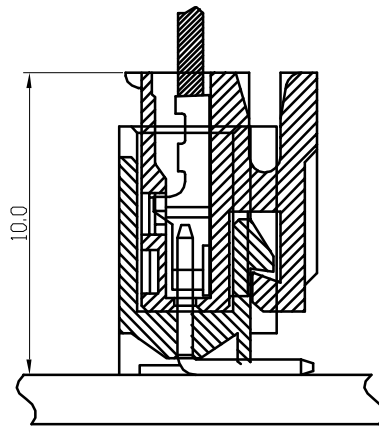

旧底图总号

底图总号

签字

日期

|         |       |            |         |    |  |  |  |
|---------|-------|------------|---------|----|--|--|--|
| 序号      |       |            |         | 图号 |  |  |  |
| 未注公差    |       |            |         |    |  |  |  |
| X.° ±3° |       | X.X° ±0.1° |         |    |  |  |  |
| >0-3    | >3-18 | >18-50     | >50-100 |    |  |  |  |
| ±0.12   | ±0.15 | ±0.3       | ±0.5    |    |  |  |  |
| 制作      | 审核    | 批准         |         |    |  |  |  |

# PHB连接器承认图面

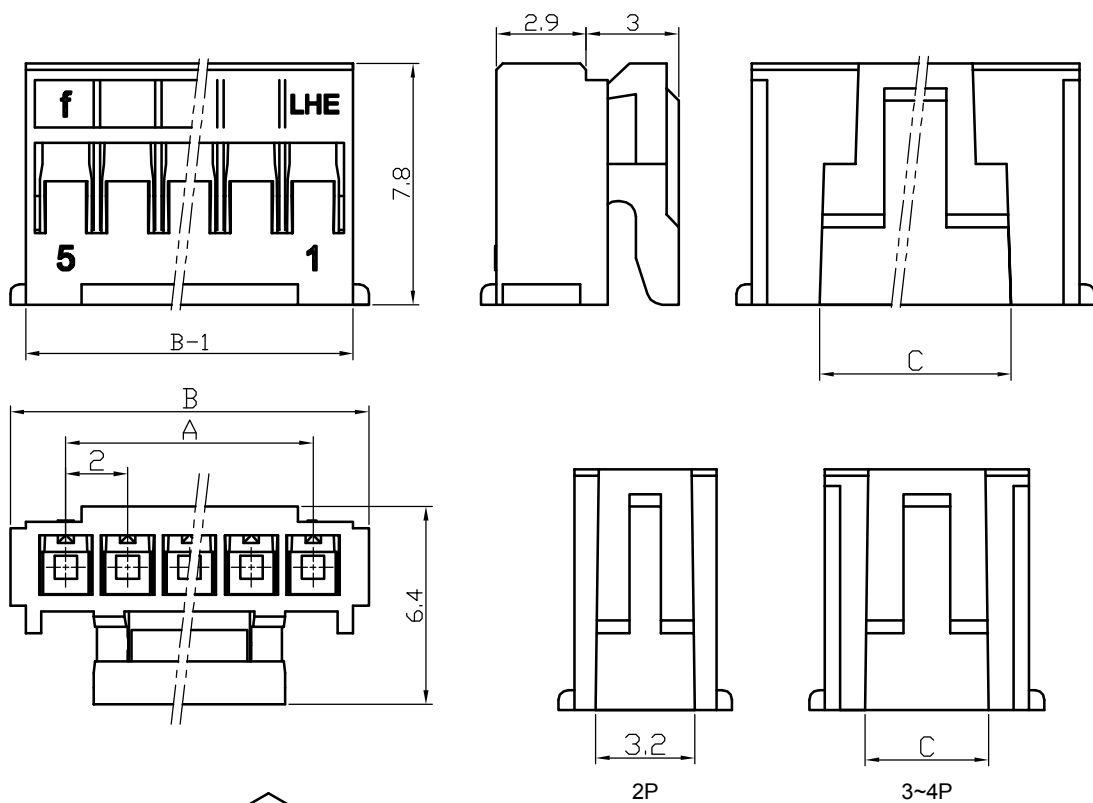

| Poles |     |
|-------|-----|
| 2     | A2C |
| 3     | A2C |
| 4     | A2C |
| 5     | A2C |
| 6     | A2C |
| 7     | A2C |
| 8     | A2C |
| 9     | A2C |
| 10    | A2C |
| 11    | A2C |
| 12    | A2C |
| 13    | A2C |
| 14    | A2C |
| 15    | A2C |
| 16    | A2C |

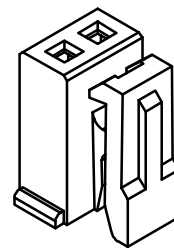
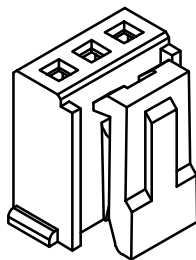
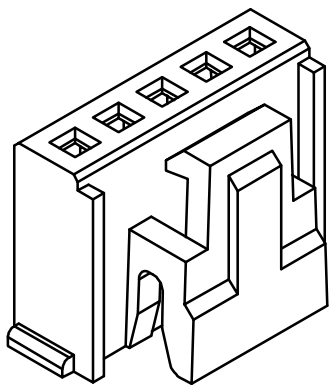

|                   |       |        |         |
|-------------------|-------|--------|---------|
| 1                 |       |        |         |
| 序号                | 图号    |        |         |
| 未注公差              |       |        |         |
| X.° ±3° X.X° ±0.5 |       |        |         |
| >0-3              | >3-18 | >18-50 | >50-120 |
| ±0.12             | ±0.15 | ±0.3   | ±0.5    |
| 制作                | 审核    | 批准     |         |

|       |  |
|-------|--|
| 旧底图总号 |  |
| 底图总号  |  |
| 签字    |  |
| 日期    |  |

# PHB连接器承认图面

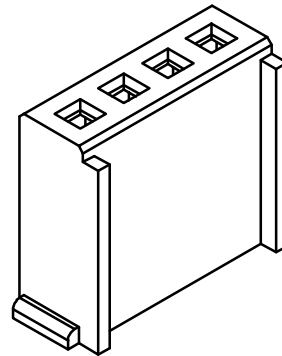
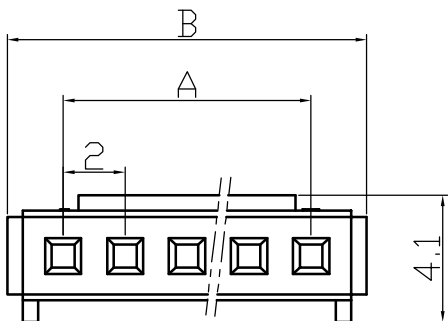
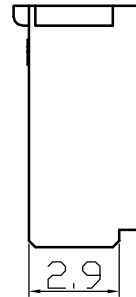
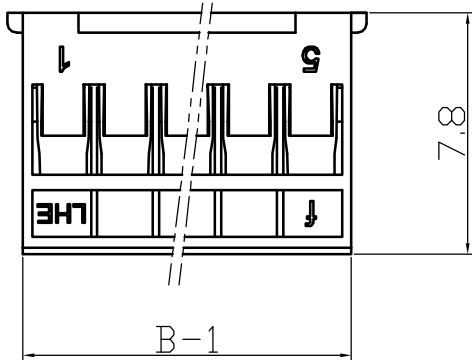

| Poles |
|-------|
| 2     |
| 3     |
| 4     |
| 5     |
| 6     |
| 7     |
| 8     |
| 9     |
| 10    |
| 11    |
| 12    |
| 13    |
| 14    |
| 15    |
| 16    |

| 1                 |       |        |        |
|-------------------|-------|--------|--------|
| 序号                | 图号    |        |        |
| 未注公差              |       |        |        |
| X.° ±3° X.X° ±0.5 |       |        |        |
| >0-3              | >3-18 | >18-50 | >50-12 |
| ±0.12             | ±0.15 | ±0.3   | ±0.5   |
| 制作                | 审核    | 批准     |        |
|                   |       |        |        |

|       |
|-------|
| 旧底图总号 |
| 底图总号  |
| 签字    |
| 日期    |



# PHB-T端子承认图面

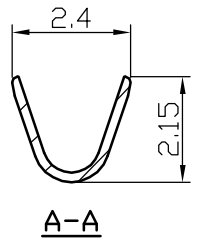
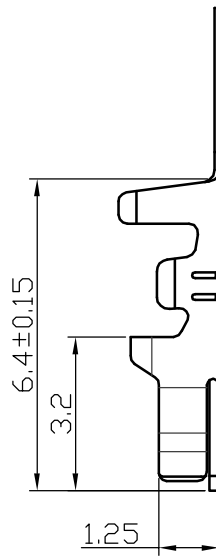
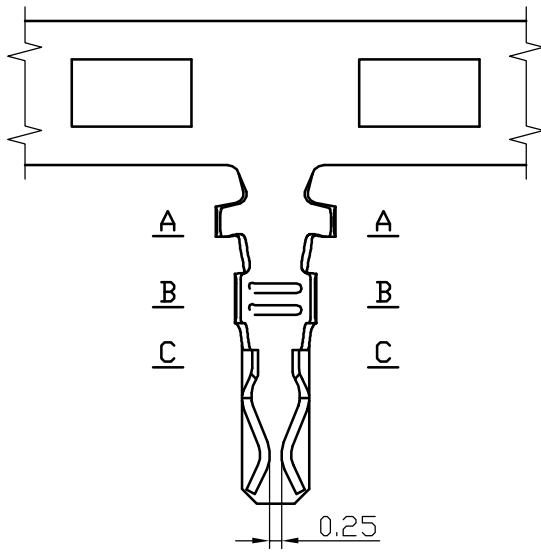

## 主要技术参数

### Main Specifications

线数 (poles): 2 to 16P  
 额定电流 (Current rating): 3.0A AC, DC  
 额定电压 (Voltage rating): 250V AC, DC  
 温度范围 (Temperature range): -25°C to +85°C  
 接触电阻 (Contact resistance):  $\leq 30\text{m}\Omega$   
 绝缘电阻 (Insulation resistance):  $\geq 1000\text{M}\Omega$   
 耐电压 (Withstand voltage): 1000V AC/minute  
 适用线规 (Applicable wire): AWG #30 to #22  
 适用基板厚度 (Applicable PC board thickness): 0.8 to 1.6mm

旧底图总号

底图总号

签字

日期

|                    |         |        |         |
|--------------------|---------|--------|---------|
| 1                  | A2003-T |        |         |
| 序号                 | 料号      |        |         |
| 未注公差               |         |        |         |
| X.° ±3° X.X° ±0.5° |         |        |         |
| >0-3               | >3-18   | >18-50 | >50-100 |
| ±0.12              | ±0.15   | ±0.3   | ±0.5    |
| 制作                 | 审核      | 批准     |         |

# PHB连接器承认图面

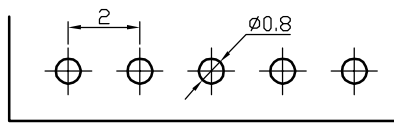
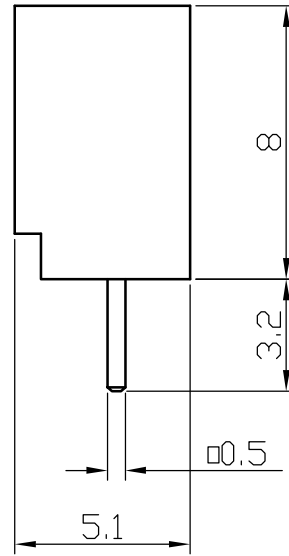
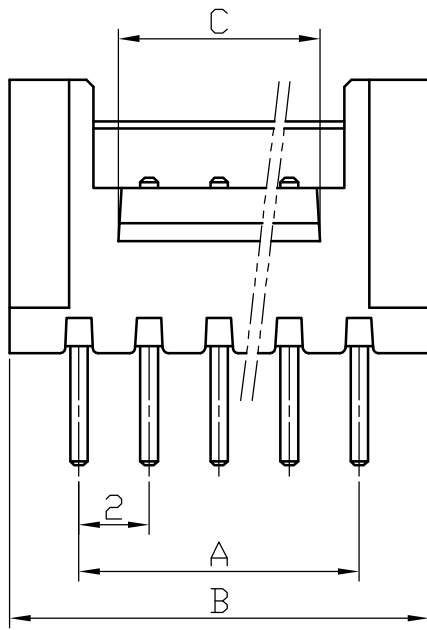

P. C. B LAYOUT

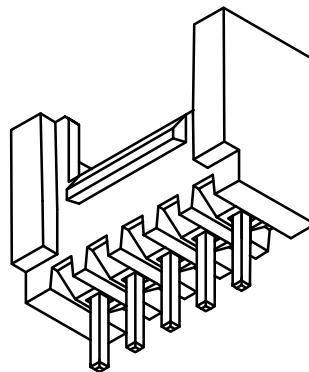

| Poles |        |
|-------|--------|
| 2     | A2005- |
| 3     | A2005- |
| 4     | A2005- |
| 5     | A2005- |
| 6     | A2005- |
| 7     | A2005- |
| 8     | A2005- |
| 9     | A2005- |
| 10    | A2005- |
| 11    | A2005- |
| 12    | A2005- |
| 13    | A2005- |
| 14    | A2005- |
| 15    | A2005- |
| 16    | A2005- |

|                   |       |        |
|-------------------|-------|--------|
| 2                 |       |        |
| 1                 |       |        |
| 序号                | 图号    |        |
| 未注公差              |       |        |
| X.° ±3° X.X° ±0.5 |       |        |
| >0-3              | >3-18 | >18-50 |
| ±0.12             | ±0.15 | ±0.3   |
| ±0.5              |       |        |
| 制作                | 审核    | 批准     |

旧底图总号  
底图总号  
签字  
日期

# PHB连接器承认图面

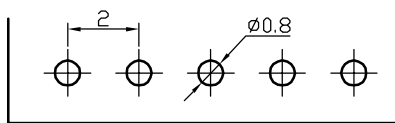
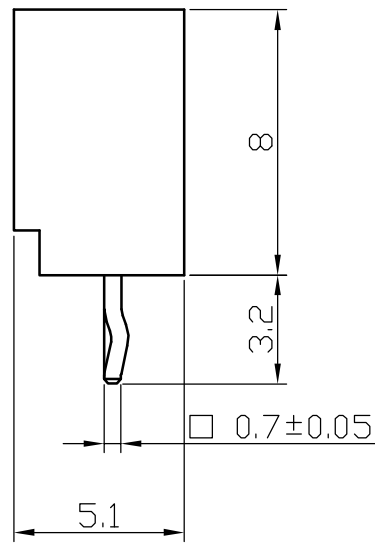
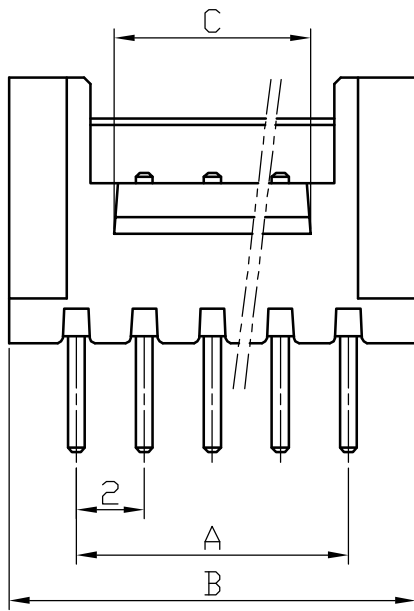

P. C. B LAYOUT

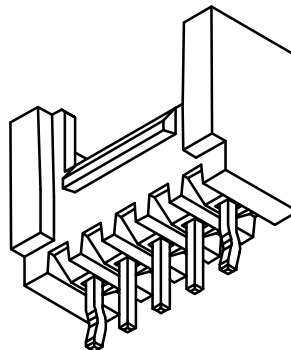

| Poles |        |
|-------|--------|
| 2     | A2005- |
| 3     | A2005- |
| 4     | A2005- |
| 5     | A2005- |
| 6     | A2005- |
| 7     | A2005- |
| 8     | A2005- |
| 9     | A2005- |
| 10    | A2005- |
| 11    | A2005- |
| 12    | A2005- |
| 13    | A2005- |
| 14    | A2005- |
| 15    | A2005- |
| 16    | A2005- |

| 2                 |       |        |        |
|-------------------|-------|--------|--------|
| 1                 |       |        |        |
| 序号                | 图号    |        |        |
| 未注公差              |       |        |        |
| X.° ±3° X.X° ±0.5 |       |        |        |
| >0-3              | >3-18 | >18-50 | >50-12 |
| ±0.12             | ±0.15 | ±0.3   | ±0.5   |
| 制作                | 审核    | 批准     |        |

旧底图总号  
底图总号  
签字  
日期

# PHB连接器承认图面

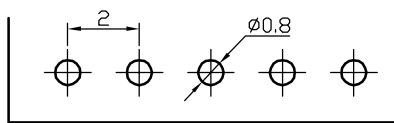
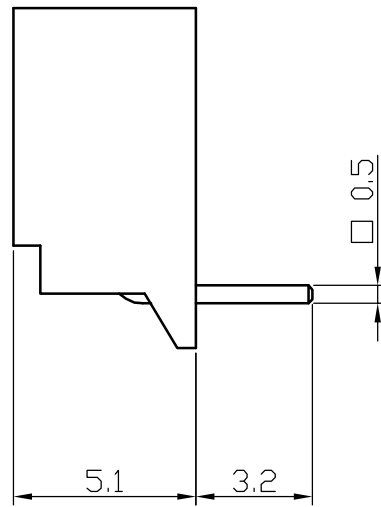
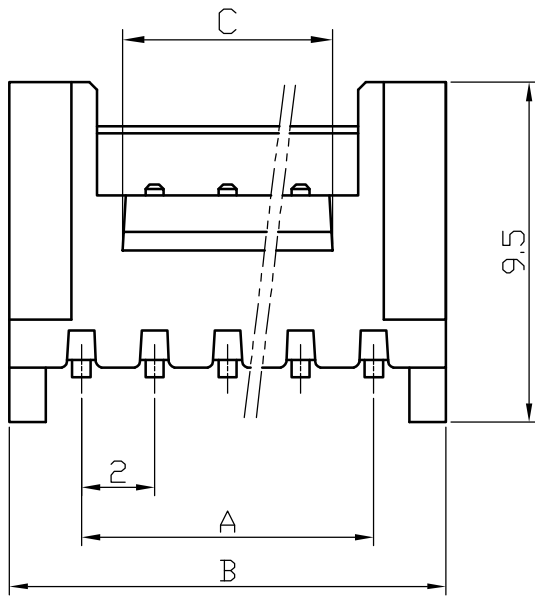

P. C. B LAYOUT

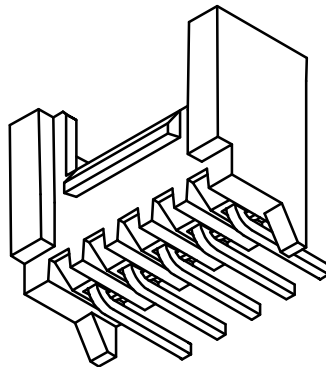

| Poles |        |
|-------|--------|
| 2     | A2005- |
| 3     | A2005- |
| 4     | A2005- |
| 5     | A2005- |
| 6     | A2005- |
| 7     | A2005- |
| 8     | A2005- |
| 9     | A2005- |
| 10    | A2005- |
| 11    | A2005- |
| 12    | A2005- |
| 13    | A2005- |
| 14    | A2005- |
| 15    | A2005- |
| 16    | A2005- |

| 2                 |       |        |         |
|-------------------|-------|--------|---------|
| 1                 |       |        |         |
| 序号                | 图号    |        |         |
| 未注公差              |       |        |         |
| X.° ±3° X.X° ±0.5 |       |        |         |
| >0-3              | >3-18 | >18-50 | >50-120 |
| ±0.12             | ±0.15 | ±0.3   | ±0.5    |
| 制作                | 审核    | 批准     |         |

旧底图总号  
底图总号  
签字  
日期

# PHB连接器承认图面

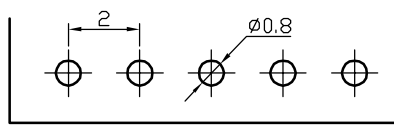
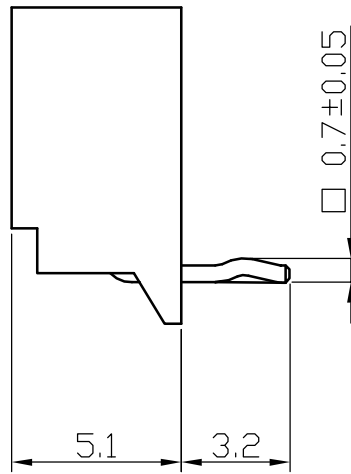
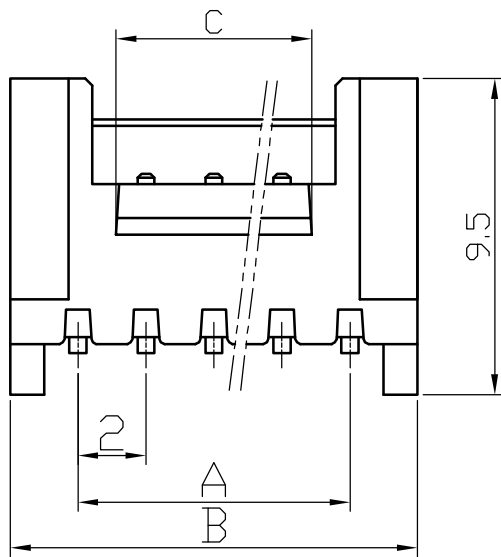

P. C. B LAYOUT

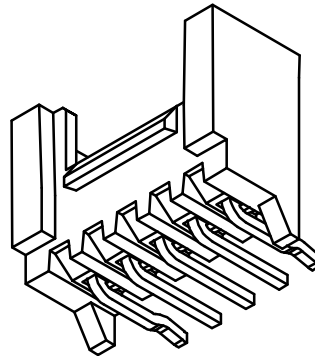

| Poles |         |
|-------|---------|
| 2     | A2005-1 |
| 3     | A2005-1 |
| 4     | A2005-1 |
| 5     | A2005-1 |
| 6     | A2005-1 |
| 7     | A2005-1 |
| 8     | A2005-1 |
| 9     | A2005-1 |
| 10    | A2005-1 |
| 11    | A2005-1 |
| 12    | A2005-1 |
| 13    | A2005-1 |
| 14    | A2005-1 |
| 15    | A2005-1 |
| 16    | A2005-1 |

| 2  |            |           |           |
|--|------------|-----------|-----------|
| 1  |            |           |           |
| 序号   | 图号         |           |           |
| 未注公差   |            |           |           |
| $X.^{\circ} \pm 3^{\circ}$ $X.X^{\circ} \pm 0.5$ |            |           |           |
| $>0-3$   | $>3-18$    | $>18-50$  | $>50-120$ |
| $\pm 0.12$                                       | $\pm 0.15$ | $\pm 0.3$ | $\pm 0.5$ |
| 制作   | 审核         | 批准        |           |

旧底图总号  
底图总号  
签字  
日期

# PHB连接器承认图面

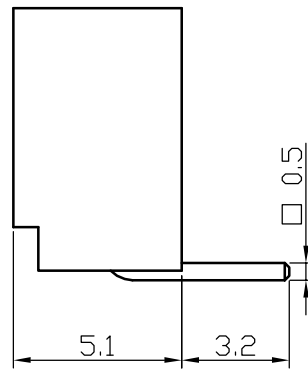
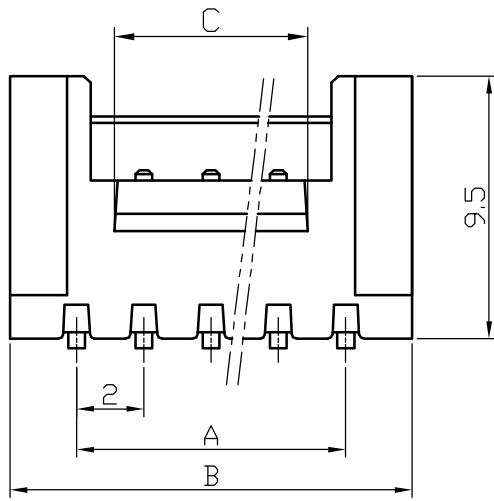

| Poles |    |
|-------|----|
| 2     | A2 |
| 3     | A2 |
| 4     | A2 |
| 5     | A2 |
| 6     | A2 |
| 7     | A2 |
| 8     | A2 |
| 9     | A2 |
| 10    | A2 |
| 11    | A2 |
| 12    | A2 |
| 13    | A2 |
| 14    | A2 |
| 15    | A2 |
| 16    | A2 |

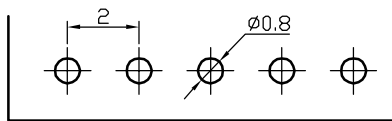

P. C. B LAYOUT

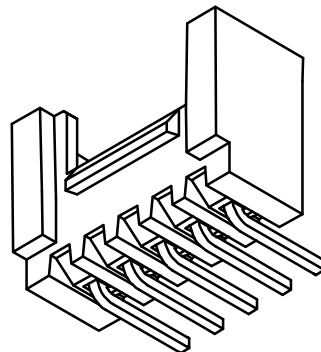

| 2                 |       |        |         |
|-------------------|-------|--------|---------|
| 1                 |       |        |         |
| 序号                | 图号    |        |         |
| 未注公差              |       |        |         |
| X.° ±3° X.X° ±0.5 |       |        |         |
| >0-3              | >3-18 | >18-50 | >50-120 |
| ±0.12             | ±0.15 | ±0.3   | ±0.5    |
| 制作                | 审核    | 批准     |         |
|                   |       |        |         |

|       |
|-------|
| 旧底图总号 |
| 底图总号  |
| 签字    |
| 日期    |

# PHB连接器承认图面

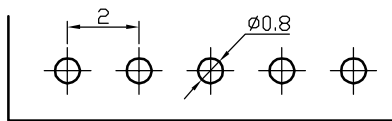
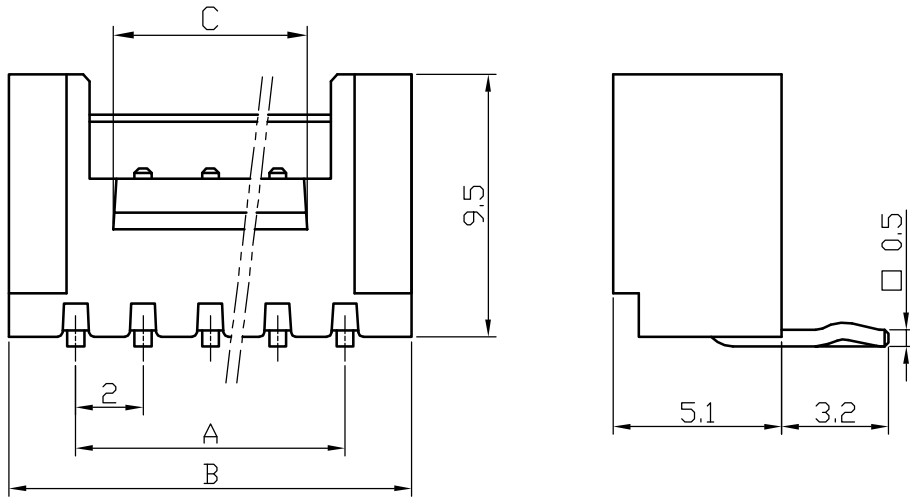

P. C. B LAYOUT

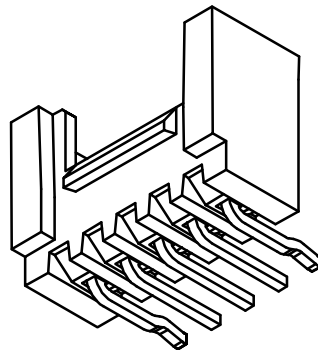

| Poles |      |
|-------|------|
| 2     | A200 |
| 3     | A200 |
| 4     | A200 |
| 5     | A200 |
| 6     | A200 |
| 7     | A200 |
| 8     | A200 |
| 9     | A200 |
| 10    | A200 |
| 11    | A200 |
| 12    | A200 |
| 13    | A200 |
| 14    | A200 |
| 15    | A200 |
| 16    | A200 |

| 2                 |       |        |        |
|-------------------|-------|--------|--------|
| 1                 |       |        |        |
| 序号                | 图号    |        |        |
| 未注公差              |       |        |        |
| X.° ±3° X.X° ±0.5 |       |        |        |
| >0-3              | >3-18 | >18-50 | >50-12 |
| ±0.12             | ±0.15 | ±0.3   | ±0.5   |
| 制作                | 审核    | 批准     |        |
|                   |       |        |        |

旧底图总号

底图总号

签字

日期

# PHB型连接器承认图面

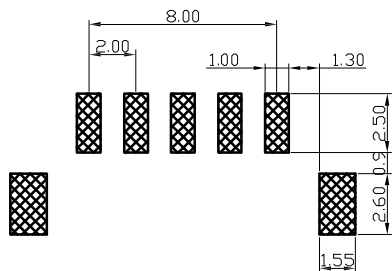
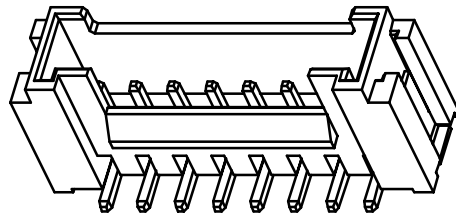
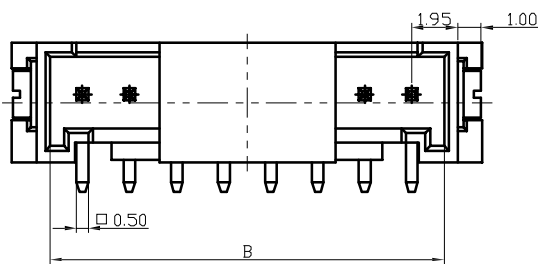
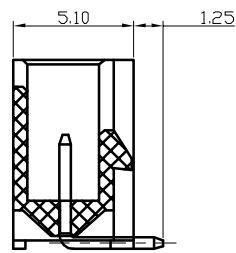
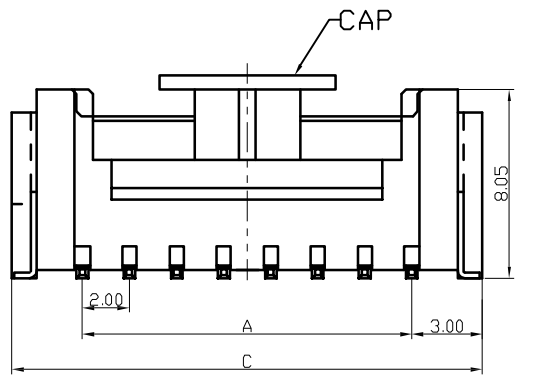

P. C. B LAYOUT

|         |           |
|---------|-----------|
| 3       | 基座        |
| 2       | 焊片        |
| 1       | 针脚        |
| 序号      | 名         |
| 未注公差    |           |
| X.° ±3° | X. X° ±0. |
| >0~3    | >3~18     |
| >18~50  | >50~      |
| ±0.15   | ±0.2      |
| ±0.3    | ±0.       |
| 制作      | 审核        |
|         | 批准        |

旧底图总号

底图总号

签字

日期

M

L

K

J

H

G

◆

F

E

D

C

B

A

15

14

13

12

11

10

9

◆

8

7

6



# PHB型连接器承认图面

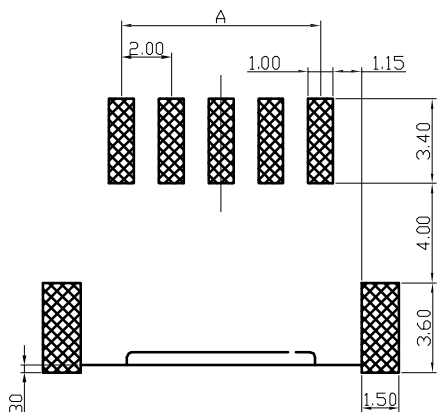
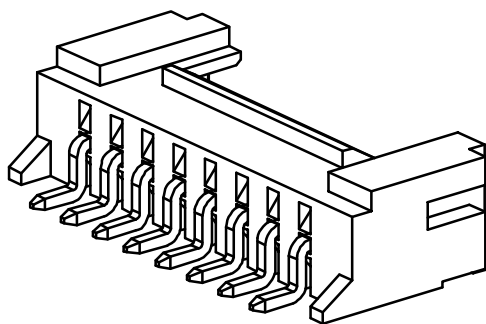
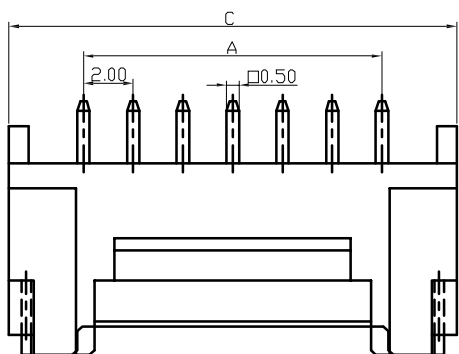
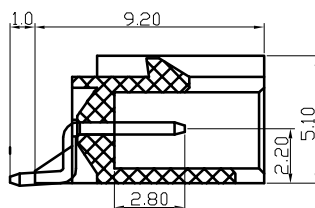
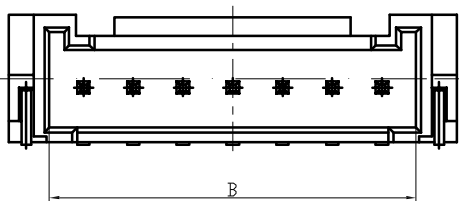

P. C. B LAYOUT

旧底图总号

底图总号

签字

日期

|         |           |        |      |
|---------|-----------|--------|------|
| 3       | 基座        |        |      |
| 2       | 焊片        |        |      |
| 1       | 针脚        |        |      |
| 序号      | 名         |        |      |
| 未注公差    |           |        |      |
| X.° ±3° | X. X° ±0. |        |      |
| >0~3    | >3~18     | >18~50 | >50~ |
| ±0.15   | ±0.2      | ±0.3   | ±0.  |
| 制作      | 审核        | 批准     |      |

# PHB型连接器

## 产品规格书

PRODUCT SPECIFICATION

版本号

Version Number:     A    

产品编码

Part Number:     A2005    

### 规格 Specifications

- ◆1、极数 Poles: 2 to 16P
- ◆2、额定电流 Current rating: 3.0A AC, DC
- ◆3、额定电压 Voltage rating: 250V AC, DC
- ◆4、温度范围 Temperature range: -25°C to +85°C
- ◆5、接触电阻 Contact resistance:  $\leq 30\text{m}\Omega$
- ◆6、绝缘电阻 Insulation resistance:  $\geq 1000\text{M}\Omega$
- ◆7、耐电压 Withstand voltage: 1000V AC/minute
- ◆8、适用线规 Applicable wire: AWG #30 to #22
- ◆9、适用基板厚度 Applicable PC board thickness: 0.8mm to 1.6mm

| 产品性能测试 Performance test |                               |  |  |
|-------------------------|-------------------------------|--|--|
|                         | 项目 Item                       | 测试条件 Test Condition  | 规格要求 Requirement   |
| 1                       | 外观<br>Appearance              | 目测 Visual by eye<br>视力 Light: >1.0<br>照明 Lamp: 200~300Lx<br>目测距离 Space: 0.3~0.5m   | 1. 塑料件表面应无明显疤痕、凹陷、开裂及影响使用的变形。<br>Plastic part: smooth and flat surface without discolor, broken, crack distortion defects is acceptable.<br>2. 金属件表面无锈蚀、氧化、无明显的机械损伤等缺陷。<br>Metal part: tight and even surface without rust, oxide, fog and obvious physical damage defects is acceptable.<br>3. 导线表面清洁、无破损等缺陷, 印字及标志清晰。<br>Wire: clearing surface without discolor, broken defects, indistinct words and mark is acceptable. |
| 2                       | 接触电阻<br>Contact Resistance    | 插合连接器, 用小功率电路进行测试。<br>Mate connectors, measure by dry circuit.   | 40mΩ MAX   |
| 3                       | 绝缘电阻<br>Insulation Resistance | 在相邻接触件之间或地线之间, 用500V DC电压进行测试。<br>Apply 500V DC between adjacent terminal or ground.   | 1000MΩ MIN   |
| 4                       | 耐电压<br>Dielectric Strength    | 相邻接触件之间或地线之间施加50Hz 800V AC(有效值), 漏电流1mA的电压作用, 时间1min。<br>Mate connectors, apply 1000V AC for 1 minute between adjacent terminal or ground. | 无击穿和飞弧现象<br>No Breakdown   |

# PHB型连接器

## 产品规格书

PRODUCT SPECIFICATION

版本号

Version Number:     A    

产品编码

Part Number:     A2005    

| 产品性能测试 Performance test |   |   |   |  |
|-------------------------|---|---|---|--|
|                         | 项目 Item   | 测试条件 Test Condition   | 规格要求 Requirement  |  |
| 5                       | 压着部位抗张强度<br>Crimping Pull<br>Out Force          | 在试验装置夹头中固定测试样品, 在连接的轴线方向施加张力; 速度不大于25mm/min。<br>Fix the crimped terminal, apply axial pull out force on the wire at the speed rate of not more 25mm/min.    | AWG #22<br>AWG #24<br>AWG #26<br>AWG #28<br>AWG #30           | 30N MIN<br>20N MIN<br>15N MIN<br>10N MIN<br>8N MIN |
| 6                       | 壳体/端子固定力<br>Terminal/Housing<br>Retention Force | 固定连接器或测力计, 在连接器轴线方向施加规定的拉力; 速度不大于25mm/min。<br>Apply axial pull out force at the speed rate of not more 25mm/min on the pin assembled in the housing.        | 10N MIN   |  |
| 7                       | 针的固定力<br>Pin Retention<br>Force                 | 固定连接器或测力计, 在连接器轴线方向对针施加规定的推力; 速度不大于25mm/min。<br>Apply axial push out force at the speed rate of not more 25mm/minute on the terminal assembled in the base. | 10N MIN   |  |
| 8                       | 可焊性<br>Solderability                            | 把测试样品需要焊接的部位浸入焊锡炉中 (锡炉温度245°C±5°C) 2±0.5秒钟。<br>Soldering time: 2±0.5 second<br>Solder Temperature: 245°C±5°C  | 上锡率≥90%<br>90% of immersed area must show no voids, pin holes |  |
| 9                       | 耐焊接热<br>Resistance to<br>Soldering Heat         | 把测试样品需要焊接的部位浸入焊锡炉中 (锡炉温度260°C±5°C); 4~6秒钟后在正常的条件下恢复1小时。<br>Soldering time: 4~6 second<br>Solder Temperature: 260°C±5°C                                      | 外观<br>Appearance  | 无损伤<br>No Damage                                   |
| 10                      | 耐高温<br>Heat Resistance                          | 连接器配合后, 于85°C±2°C的空气中放置96小时, 然后再回到室温中放置1~2h小时测定<br>Mated connectors are exposed to a temperature of 85°C±2°C for 96 hours.                                  | 外观<br>Appearance<br>接触电阻<br>LLCR                              | 无损伤<br>No Damage<br>40mΩ Max                       |
| 11                      | 耐低温<br>Cold Resistance                          | 连接器配合后, 于-25°C±2°C的空气中放置96小时, 然后再回到室温中放置1~2h小时测定<br>Mated connectors are exposed to a temperature of -25°C±2°C for 96 hours.                                | 外观<br>Appearance<br>接触电阻<br>LLCR                              | 无损伤<br>No Damage<br>40mΩ Max                       |
| 12                      | 温度上升<br>Temperature Rise                        | 插入连接器, 通以最大允许电流。<br>Carrying rated current load.  | 温度最大上升<br>Temperature<br>Rise                                 | 60°C MAX   |

# PHB型连接器

## 产品规格书

PRODUCT SPECIFICATION

版本号

Version Number:     A    

产品编码

Part Number:     A2005    

| 产品性能测试 Performance test |   |   |                               |                      |
|-------------------------|---|---|-------------------------------|----------------------|
|                         | 项目 Item                                   | 测试条件 Test Condition   | 规格要求 Requirement              |                      |
| 13                      | 恒定湿热<br>Humidity                          | 温度: $40 \pm 2^{\circ}\text{C}$<br>相对湿度: 90%~95%<br>搁置时间: 96小时, 取出恢复2h后检查<br>Temperature: $40 \pm 2^{\circ}\text{C}$<br>Relative Humidity: 90%~95%<br>Duration: 96 hours   | 外观<br>Appearance              | 无损伤<br>No Damage     |
|                         |   |   | 耐电压<br>Dielectric Strength    | 1000V, AC<br>/minute |
|                         |   |   | 绝缘电阻<br>Insulation Resistance | 1000M $\Omega$ MIN   |
|                         |   |   | 接触电阻 LLCR                     | 40m $\Omega$ MAX     |
| 14                      | 温度循环<br>Temperature cycle                 | 把测试样品放入高低温试验箱中, 按下列步骤调试温度:<br>a) 在 $-25^{\circ}\text{C} \pm 2^{\circ}\text{C}$ 的恒温条件下放置0.5小时;<br>b) 在 $85^{\circ}\text{C} \pm 2^{\circ}\text{C}$ 的恒温条件下放置0.5小时;<br>从a)到b)为一个循环周期, 共进行5个循环。<br>恢复1h后检查。状态转换时间不多于1小时。<br>Mated connectors are exposed to 5 cycles of:<br>a) $-25^{\circ}\text{C} \pm 2^{\circ}\text{C}$ 0.5hour<br>b) $+85^{\circ}\text{C} \pm 2^{\circ}\text{C}$ 0.5hour | 外观<br>Appearance              | 无损伤<br>No Damage     |
|                         |   |   | 耐电压<br>Dielectric Strength    | 1000V, AC<br>/minute |
|                         |   |   | 绝缘电阻<br>Insulation Resistance | 1000M $\Omega$ MIN   |
|                         |   |   | 接触电阻 LLCR                     | 40m $\Omega$ MAX     |
| 15                      | 机械振动<br>Vibration                         | 插合连接器, 串联在一直流电源上, 电流100mA; 并模拟正常工作状态, 振频为10~55Hz、振幅1.5mm; 55~500Hz、加速度 $50\text{m/s}^2$ , 每一轴线扫频循环次数10次、2小时。<br>Frequency: 10~55Hz<br>Amplitude: $\pm 1.5\text{mm}$<br>Frequency: $> 55 \sim 500\text{Hz}$<br>Acceleration: $50\text{m/s}^2$<br>Duration: 2 hours in each X,Y,Z axes  | 外观<br>Appearance              | 无损伤<br>No Damage     |
|                         |   |   | 接触电阻<br>Contact Resistance    | 40m $\Omega$ MAX     |
|                         |   |   | 中断<br>Intermittence           | 1 $\mu$ sec MAX      |
| 16                      | 机械寿命<br>Repeated insertion/<br>withdrawal | 以每分钟插拔10次的速率, 插拔50次。<br>When mated up to 50 cycles repeatedly by the rate of 10 cycles per minute.  | 外观<br>Appearance              | 无损伤<br>No Damage     |
|                         |   |   | 耐电压<br>Dielectric Strength    | 1000V, AC<br>/minute |
|                         |   |   | 绝缘电阻<br>Insulation            | 100M $\Omega$ MIN    |
|                         |   |   | 接触电阻<br>Contact Resistance    | 40m $\Omega$ MAX     |

# PHB型连接器

## 产品规格书

PRODUCT SPECIFICATION

版本号

Version Number:     A    

产品编码

Part Number:     A2005    

| 产品性能测试 Performance test |   |  |  |
|-------------------------|---|--|--|
|                         | 项目 Item   | 测试条件<br>Test Condition   | 规格要求 Requirement   |
| 17                      | 盐雾<br>Salt Spray                                | 把先冲后镀* 的测试样品从试验箱顶悬挂下来，采用浓度为5%±1(质量百分比)的氯化钠溶液，连续雾化16小时，试验后用流动的蒸馏水轻轻洗去表面沉积物。在常温常驻湿条件下恢复1~2小时。<br>16 hour exposure to a saltspray from the 5%±1 solution. | 外观无损伤(五金件应无露出底金属的严重锈蚀；使用预镀的型材，其落料面允许有不影响其性能的轻微腐蚀。)。<br>Appearance: No Damage (No erosion with material exposed. And with plating material, slight erosion on the cutting surface acceptable) |
| 18                      | 插入力与拔出力<br>Insertion and<br>Withdrawal<br>Force | 单pin相配的接触件以1mm/s~5mm/s的速度沿接插器轴线方向插入和拔出。<br>Insertion and withdraw connectors at the speed rate of 1mm/s~5mm/s.   | 插入力(最大值)<br>Insertion (Max)  |
|                         |   |  | 拔出力(最小值)<br>Withdrawal (Min)   |
|                         |   |  | 7.5N   |
|                         |   |  | 1.0N   |

\* 先冲后镀为定制端子。常规端子为先镀后冲，无法通过盐雾试验。

制订 \_\_\_\_\_ 日期 \_\_\_\_\_  
Edit: \_\_\_\_\_ Date: \_\_\_\_\_

审核 \_\_\_\_\_ 日期 \_\_\_\_\_  
Check: \_\_\_\_\_ Date: \_\_\_\_\_

批准 \_\_\_\_\_ 日期 \_\_\_\_\_  
Approval: \_\_\_\_\_ Date: \_\_\_\_\_

## 检测报告

|  |                                     |      |     |      |      |        |     |      |     |      |   |
|--|-------------------------------------|------|-----|------|------|--------|-----|------|-----|------|---|
| 产品名称   | PHB-Y与PHB-YT                        |      |     |      | 测试组数 | 1组（每组5 |     |      |     |      |   |
| 测试方法   | 将连接器固定在测力计上，再对着连接器轴线方向施加推           |      |     |      |      |        |     |      |     |      |   |
| 测试标准   | 胶壳的端子的插入力 $\leq 8N$ 、拔出力 $\geq 10N$ |      |     |      |      |        |     |      |     |      |   |
| 测试数据   | 1                                   |      | 2   |      | 3    |        | 4   |      | 5   |      | 最 |
| 第一组  | 插入力                                 | 3.0  | 插入力 | 3.0  | 插入力  | 2.5    | 插入力 | 3.0  | 插入力 | 3.5  |   |
|  | 拔出力                                 | 27.0 | 拔出力 | 27.5 | 拔出力  | 28.0   | 拔出力 | 27.5 | 拔出力 | 26.0 | 2 |
| 备注：数据会随湿度变化，不宜长时间放在过于潮湿的环境。拔出时线先拔出，则将线木<br>视为拔出力。单位N |                                     |      |     |      |      |        |     |      |     |      |   |
| 综合判定   | 合格                                  |      |     |      |      | 测试员    | 吴智原 |      |     |      |   |



## 检测报告

|  |                           |      |       |      |       |        |       |      |       |      |   |
|--|---------------------------|------|-------|------|-------|--------|-------|------|-------|------|---|
| 产品名称   | PHB-2Y与PHB-2A             |      |       |      | 测试组数  | 1组（每组5 |       |      |       |      |   |
| 测试方法   | 将连接器固定在测力计上，再对着连接器轴线方向施加推 |      |       |      |       |        |       |      |       |      |   |
| 测试标准   | 胶壳拔出力 $\geq 10N$          |      |       |      |       |        |       |      |       |      |   |
| 测试数据   | 1                         |      | 2     |      | 3     |        | 4     |      | 5     |      | 最 |
| 第一组  | 第1次                       | 28.5 | 第1次   | 25.5 | 第1次   | 20.0   | 第1次   | 27.5 | 第1次   | 26.5 | 2 |
|  | 第500次                     | 14.0 | 第500次 | 12.5 | 第500次 | 17.5   | 第500次 | 19.0 | 第500次 | 19.5 | 1 |
| 备注：数据会随湿度变化，不宜长时间放在过于潮湿的环境。拔出时线先拔出，则将线木<br>视为拔出力。单位N |                           |      |       |      |       |        |       |      |       |      |   |
| 综合判定   | 合格                        |      |       |      |       | 测试员    | 吴智原   |      |       |      |   |

# 试 验 报 告

试验项目:针焰实验

试验日期: 2016/11/17

|         |  |  |                 |
|---------|--|--|-----------------|
| 产品或零件名称 | PA66 94V0 样条   | 生产单位   | 注塑              |
| 样品数量    | 各 3PCS   | 检验标准   | GB/T5169.5-2008 |
| 检验设备    | 针焰试验箱  | 进货批号   | /               |
| 标准要求    | 指 标  | a. 试验样品无火焰和灼热，并且规定的铺底层或包装绢纸没有起燃<br>b. 在移开针焰后，试验样品和周围的零部件的火焰或灼热在 30s 之内熄灭，即 $t_b < 30s$ ，而且周围的零部件没有完全烧毁，以及规定的铺底层或包装绢纸没有起燃 |                 |
|         | 试 验 条 件  | 施加试验火焰持续时间为 12s。火焰高度 12mm ± 1mm。   |                 |
| 试验结果    | <div style="display: flex; justify-content: space-around;">   </div> <p>产品施焰时间 12s, 续燃时间 2.6s。无滴落物。</p> |  |                 |
| 判定      | 符合要求   |  |                 |
|         | 实验员: 唐安英   |  | 审核员: 熊英         |

表单编号: QR/LHE-PZ-019

版本: B/0



# 盐雾试验报告

|                  |                       |                     |                |          |     |
|------------------|-----------------------|---------------------|----------------|----------|-----|
| 试验日期：2016年10月16日 |                       | 试验号码：201610168009   |                |          |     |
| 试验方法：NSS         |                       | 试验标准：GB/T10125-1997 |                |          |     |
| 客户名称：            |                       |                     |                |          |     |
| 试 样              | 品 名                   | 金属端子                | 镀层厚度           | Cu:1~2.5 | μm  |
|                  | 材 质                   | CuZn                |                | Sn:3~5   | 3μm |
|                  | 试验前外观                 | 银白色                 | 数 量            | 30 枚     |     |
| 试 验<br><br>条 件   | 试验时间：16日 16时 至 17日 8时 |                     |                |          |     |
|                  | 喷雾时间：16小时             |                     | 保温时间：0小时       |          |     |
|                  | 试验室温度：37±1℃           |                     | 压力桶温度：45±1℃    |          |     |
|                  | 试验室相对湿度：65%~75%       |                     | 大气压：101~102kpa |          |     |
|                  | NACL 浓度：5%±0.5%       |                     | PH 值：7.0（中性）   |          |     |
| 试 验<br><br>描 述   | 试验后外观                 | 合格                  |                |          |     |
|                  | 去除腐蚀<br>产物后外观         | 正常                  |                |          |     |
| 试 验<br><br>结 果   | 合格                    |                     |                |          |     |
| 备 注              |                       |                     |                |          |     |



## ECBT2.E364711

## Connectors for Use in Data, Signal, Control and Power Applications - Component

[Page Bottom](#)

## Connectors for Use in Data, Signal, Control and Power Applications - Component

[See General Information for Connectors for Use in Data, Signal, Control and Power Applications - Component](#)

ZHEJIANG LIANHE ELECTRONIC CO LTD  
 HOUYU VILLAGE SHIFAN TOWN  
 YUEQING, ZHEJIANG 325608 CHINA

E364711

Connector, Model(s) Series 1.25, 1254, 1255, followed by -2 thru -25, followed by Y(T), A or AW

Series 5264, followed by -2 thru -16, followed by Y(T), A or AWD

Series PH, PHB, XHB, JC25, SCN, followed by -2 thru -20, followed by Y(T), A, AW or AWD

Series SM, followed by -2 thru -18, followed by Y(T) or A(T)

Series VH, 3.96, followed by -2 thru -16, followed by Y(T), A, AW or AWG

Series XH, followed by -2 thru -20, followed by Y(T), A, AW, AWGD, AWD or AWGDJ

Marking: Company name or trademark **CAX**, model designation and the Recognized Component Mark,  on the device or carton.

[Last Updated](#) on 2013-10-10

[Questions?](#)[Print this page](#)[Terms of Use](#)[Page Top](#)

◆ 2016 UL LLC

The appearance of a company's name or product in this database does not in itself assure that products so identified have been manufactured under UL's Follow-Up Service. Only those products bearing the UL Mark should be considered to be Certified and covered under UL's Follow-Up Service. Always look for the Mark on the product.

UL permits the reproduction of the material contained in the Online Certification Directory subject to the following conditions: 1. The Guide Information, Assemblies, Constructions, Designs, Systems, and/or Certifications (files) must be presented in their entirety and in a non-misleading manner, without any manipulation of the data (or drawings). 2. The statement "Reprinted from the Online Certifications Directory with permission from UL" must appear adjacent to the extracted material. In addition, the reprinted material must include a copyright notice in the following format: "© 2016 UL LLC".

Verification No.: CLZJ1411264692



## VERIFICATION OF LVD COMPLIANCE

**Applicant:** Zhejiang Lianhe Electrical Co., Ltd.  
Houyu village, Shifan town, Yueqing city, Zhejiang province, China.

**Manufacturer:** Same as applicant

**Product Description:** Connector Terminal

**Model No:** A1001, A1002, A1003, A1251, A1252, A1253, A1254, A1255, A1256, A1257, A1501, A1502, A1503, A2001, A2002, A2003, A2004, A2005, A2006, A2007, A2501, A2502, A2503, A2504, A2505, A2506, A2507, A2541, A2542, A2543, A2544, A2545, A3961, A3962, A3963, A3564, A5081, A5082, B1501, B1502, B2001, B2002, B2501, B2502, C01581, C01582, C1251, C2001, C2002, C2501, C2502, C2505, C2506, C3001, C3002, C3003, C3004, C3005, C3006, C3501, C3502, C3701, C3702, C4001, C4002, C4141, C4142, C4201, C4202, C4203, C4204, C4601, C4602, C4501, C4502, C4503, C4504, C5001, C5002, C5031, C5032, C6201, C6202, C6351, C6352, C6701, C6702, D2801, D2802, D2803, D4801, D4802, D4803, D4804, D6301, D6302, D6303

Sufficient samples of the product have been tested and found to be in conformity with

**Test Standard:** EN 60320-1:2001/A1:2007  
EN 60529:1991/A1:2000

As shown in the  
**Test Report Number(s):** TLZJ1411264692  
**Date of issue:** November 27, 2014

### Conclusion

This Verification of LVD Compliance has been granted to the applicant based on the results of tests, performed by laboratory of Global Testing Services Co., Ltd on sample of the above-mentioned product in accordance with the provisions of the relevant specific standards and the Low Voltage Directive 2014/35/EU. The CE marking as shown below can be affixed, under the responsibility of the manufacturer, after completion of an EC Declaration of Conformity and compliance with all relevant EC Directives. The affixing of the CE marking presumes in addition that conditions the conditions in annexes III and IV of the Directive are fulfilled.

Approved by: Hermann Weiser

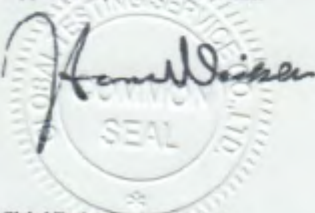

For and on behalf of  
Global Testing Services Co., Ltd



Global Testing Services Co., Ltd  
E-mail: info@gts-lab.com <http://www.gts-lab.com>  
Room 1501-1502, No. 520 Yishan Rd., Xuhui District, Shanghai, 200235 China

Copyright of this certificate is owned by Global Testing Services Co., Ltd and may not be reproduced other than in full and with the prior approval of the General Manager.

以下测试之样品是由申请者所提供及确认:连接器

SGS工作编号: NP16-001905 - NB

主要成分: 尼龙66

锡铜

料号: A2501

型号: XH

客户参考信息: 见附件

样品接收日期: 2016年05月16日

测试周期: 2016年05月16日 - 2016年05月20日

测试要求: 根据客户要求测试

测试方法: 请参见下一页

测试结果: 请参见下一页

结论: 基于所送样品的指定部位进行的测试, 镉、铅、汞、六价铬、多溴联苯(PBBs)、多溴二苯醚(PBDEs)、邻苯二甲酸酯(如邻苯二甲酸二丁酯(DBP)、邻苯二甲酸丁苯酯(BBP)、邻苯二甲酸二(2-乙基己基)酯(DEHP)和邻苯二甲酸二异丁酯(DIBP))的测试结果符合欧盟RoHS指令2011/65/EU附录II的修正指令(EU) 2015/863的限值要求。

通标标准技术服务有限公司宁波分公司  
授权签名

Iris Xiao 肖玲艳  
批准签署人

本报告是编号为NGBEC1602080903报告的中文版本



Unless otherwise agreed in writing, this document is issued by the Company subject to its General Conditions of Service printed overleaf, available on request or accessible at <http://www.sgs.com/en/Terms-and-Conditions.aspx> and, for electronic format documents, subject to Terms and Conditions for Electronic Documents at <http://www.sgs.com/en/Terms-and-Conditions/Terms-e-Documents.aspx>. Attention is drawn to the limitation of liability, indemnification and jurisdiction issues defined therein. Any holder of this document is advised that information contained hereon reflects the Company's findings at the time of its intervention only and within the limits of Client's instructions, if any. The Company's sole responsibility is to its Client and this document does not exonerate parties to a transaction from exercising all their rights and obligations under the transaction documents. This document cannot be reproduced except in full, without prior written approval of the Company. Any unauthorized alteration, forgery or falsification of the content or appearance of this document is unlawful and offenders may be prosecuted to the fullest extent of the law. Unless otherwise stated the results shown in this test report refer only to the sample(s) tested.

Attention: To check the authenticity of testing / inspection report & certificate, please contact us at telephone: (86-755) 8307 1443, or email: [CN.Doccheck@sgs.com](mailto:CN.Doccheck@sgs.com)

14/F West of Building 4, Lingyin Industry Park, No.1177 Lingyin Road, Ningbo National Hi-Tech Zone, Ningbo, Zhejiang, China 315040 t E&E (86-574)89070249 t ML (86-574)89070242 www.sgs.com.cn  
中国·浙江·宁波市国家高新区凌云路1177号凌云产业园4号楼西1-5层 邮编: 315040 t HL (86-574)89070271 t TY (86-574)89070211 e [sgs.china@sgs.com](mailto:sgs.china@sgs.com)

# 测试报告

No. NGBEC1602080904

日期: 2016年05月25日

第2页,共7页

测试结果:

## 测试样品描述:

| 样品编号 | SGS样品ID          | 描述   |
|------|------------------|------|
| SN1  | NGB16-020809.002 | 白色塑料 |

备注:

- (1) 1 mg/kg = 0.0001%
- (2) MDL = 方法检测限
- (3) ND = 未检出 (< MDL)
- (4) "-" = 未规定

## RoHS 指令2011/65/EU附录II的修正指令(EU) 2015/863

- 测试方法:
- (1) 参考IEC 62321-5:2013, 用ICP-OES测定镉的含量
  - (2) 参考IEC 62321-5:2013, 用ICP-OES测定铅的含量
  - (3) 参考IEC 62321-4:2013, 用ICP-OES测定汞的含量
  - (4) 参考IEC 62321:2008, 用紫外-可见分光光度计比色法测定六价铬的含量
  - (5) 参考IEC 62321-6:2015, 用GC-MS测定PBBs(多溴联苯)和PBDEs(多溴二苯醚)的含量
  - (6) 参考IEC 62321-8:2013 (111/321/CD), 用GC-MS测定邻苯二甲酸酯的含量

| 测试项目           | 限值   | 单位    | MDL | 002 |
|----------------|------|-------|-----|-----|
| 镉(Cd)          | 100  | mg/kg | 2   | ND  |
| 铅(Pb)          | 1000 | mg/kg | 2   | ND  |
| 汞(Hg)          | 1000 | mg/kg | 2   | ND  |
| 六价铬(CrVI)      | 1000 | mg/kg | 2   | ND  |
| 多溴联苯(PBBs)之和   | 1000 | mg/kg | -   | ND  |
| 一溴联苯           | -    | mg/kg | 5   | ND  |
| 二溴联苯           | -    | mg/kg | 5   | ND  |
| 三溴联苯           | -    | mg/kg | 5   | ND  |
| 四溴联苯           | -    | mg/kg | 5   | ND  |
| 五溴联苯           | -    | mg/kg | 5   | ND  |
| 六溴联苯           | -    | mg/kg | 5   | ND  |
| 七溴联苯           | -    | mg/kg | 5   | ND  |
| 八溴联苯           | -    | mg/kg | 5   | ND  |
| 九溴联苯           | -    | mg/kg | 5   | ND  |
| 十溴联苯           | -    | mg/kg | 5   | ND  |
| 多溴二苯醚之和(PBDEs) | 1000 | mg/kg | -   | ND  |
| 一溴二苯醚          | -    | mg/kg | 5   | ND  |
| 二溴二苯醚          | -    | mg/kg | 5   | ND  |



Unless otherwise agreed in writing, this document is issued by the Company subject to its General Conditions of Service printed overleaf, available on request or accessible at <http://www.sgs.com/en/Terms-and-Conditions.aspx> and, for electronic format documents, subject to Terms and Conditions for Electronic Documents at <http://www.sgs.com/en/Terms-and-Conditions/Terms-e-Documents.aspx>. Attention is drawn to the limitation of liability, indemnification and jurisdiction issues defined therein. Any holder of this document is advised that information contained hereon reflects the Company's findings at the time of its intervention only and within the limits of Client's instructions, if any. The Company's sole responsibility is to its Client and this document does not exonerate parties to a transaction from exercising all their rights and obligations under the transaction documents. This document cannot be reproduced except in full, without prior written approval of the Company. Any unauthorized alteration, forgery or falsification of the content or appearance of this document is unlawful and offenders may be prosecuted to the fullest extent of the law. Unless otherwise stated the results shown in this test report refer only to the sample(s) tested.

Attention: To check the authenticity of testing / inspection report & certificate, please contact us at telephone: (86-755) 8307 1443, or email: [CN.Doccheck@sgs.com](mailto:CN.Doccheck@sgs.com)

SGS-1602 Standards Technical Services Co., Ltd. 14/F West of Building 4, Lingyin Industry Park, No.1177 Lingyin Road, Ningbo National Hi-Tech Zone, Ningbo, Zhejiang, China 315040 1 E&E (86-574)89070249 1 ML (86-574)89070242 www.sgsgroup.com.cn  
 中国·浙江·宁波市国家高新区凌云路1177号凌云产业园4号楼西1-5层 邮编: 315040 1 HL (86-574)89070271 1 TY (86-574)89070211 e sgs.china@sgs.com

# 测试报告

No. NGBEC1602080904

日期: 2016年05月25日

第3页,共7页

| 测试项目                  | 限值   | 单位    | MDL | 002 |
|-----------------------|------|-------|-----|-----|
| 三溴二苯醚                 | -    | mg/kg | 5   | ND  |
| 四溴二苯醚                 | -    | mg/kg | 5   | ND  |
| 五溴二苯醚                 | -    | mg/kg | 5   | ND  |
| 六溴二苯醚                 | -    | mg/kg | 5   | ND  |
| 七溴二苯醚                 | -    | mg/kg | 5   | ND  |
| 八溴二苯醚                 | -    | mg/kg | 5   | ND  |
| 九溴二苯醚                 | -    | mg/kg | 5   | ND  |
| 十溴二苯醚                 | -    | mg/kg | 5   | ND  |
| 邻苯二甲酸二丁酯 (DBP)        | 1000 | mg/kg | 50  | ND  |
| 邻苯二甲酸丁苄酯(BBP)         | 1000 | mg/kg | 50  | ND  |
| 邻苯二甲酸二(2-乙基己基)酯(DEHP) | 1000 | mg/kg | 50  | ND  |
| 邻苯二甲酸二异丁酯(DIBP)       | 1000 | mg/kg | 50  | ND  |

备注:

(1) 最大允许极限值引用自RoHS指令(EU) 2015/863。



Unless otherwise agreed in writing, this document is issued by the Company subject to its General Conditions of Service printed overleaf, available on request or accessible at <http://www.sgs.com/en/Terms-and-Conditions.aspx> and, for electronic format documents, subject to Terms and Conditions for Electronic Documents at <http://www.sgs.com/en/Terms-and-Conditions/Terms-e-Documents.aspx>. Attention is drawn to the limitation of liability, indemnification and jurisdiction issues defined therein. Any holder of this document is advised that information contained hereon reflects the Company's findings at the time of its intervention only and within the limits of Client's instructions, if any. The Company's sole responsibility is to its Client and this document does not exonerate parties to a transaction from exercising all their rights and obligations under the transaction documents. This document cannot be reproduced except in full, without prior written approval of the Company. Any unauthorized alteration, forgery or falsification of the content or appearance of this document is unlawful and offenders may be prosecuted to the fullest extent of the law. Unless otherwise stated the results shown in this test report refer only to the sample(s) tested.

Attention: To check the authenticity of testing /inspection report & certificate, please contact us at telephone: (86-755) 8307 1443, or email: [CN.Doccheck@sgs.com](mailto:CN.Doccheck@sgs.com)

SGS-CTC Standards Technical Services Co., Ltd 14/F West of Building 4, Lingyin Industry Park, No.1177 Lingyin Road, Ningbo National Hi-Tech Zone, Ningbo, Zhejiang, China 315040 T E&E (86-574)89070249 T ML (86-574)89070242 www.sgsgroup.com.cn  
 中国·浙江·宁波市国家高新区凌云路1177号凌云产业园4号楼西1-5层 邮编: 315040 T HL (86-574)89070271 T TY (86-574)89070211 e [sgs.china@sgs.com](mailto:sgs.china@sgs.com)

附件:

1.0 1.25 DF14 GH ZH PH PA PHSD DF11 C1251 51146 FI-S  
PHD YHD200 SMW SMH200 SMH200-H 20039WR 杜邦  
2.0 XH/TJC3 XA HA XHB EH SZN SAN SCN SCND JC15 JC20  
JC25 5264 250 LGC CH2.5 EI/小EP S11 HR 线扣 YH025 35155  
5102 5240 SMH250 SMP250 SMW250 25048HS 25045HP  
SM TJC8/杜邦2.54 TJC8A/杜邦带锁 TJC8B TJC8H 5051/2510 543  
美尚美 CH10 25415 43645 43020 43025 5500  
5600 VH VHRR/YH396 VHR 35156 2139/3.96 90331 5195 5196  
39612 FL 5557 5559 5566 5569 42474 42475 SL RV42 CL014/OTP  
EL YL 小型EL QH NV 50300 50301 8981/大四P 5058/5.08 5197  
5198 5025 L6.2 VL VLP/VLR 3191 5199 TJC2 TJC2A TJC2B STV5  
YHL500 YWL500 TJC4 TJC1 SMF Cy-X201/35108 35150 35151 35224  
35180 35965 1806 110 2.8 42021 42022 42002 6.3 250 35955 SA  
SCS 35189 35196 DF11 MX3.0  
1.58 51005 51006 BH3.5 BH4.0 EL 63080 187 250 51004 TJC15  
DF13 D4081 D4082 D6301 D6302 F1001-T11 SIN-T11 774-2P 774-3P  
774-5P 2060-401 2060-402 2060-403 773-102 773-104 773-106 773-108  
778 294 TU-JTK型叉型预绝缘端头 (SV) TU叉型裸端头 (SNB)  
TO-JTK型圆形预绝缘端头 (RV) 公预绝缘接头 (MDD) 母预绝缘接头 (FDD)  
TG-JT管型预绝缘端头 电缆防水接头 接线端子 软护套 IDC CONNECTOR AUTO  
CONNECTOR DJ7021-1.5-11 DJ7021-1.5-21 DT04  
DT06 UY/K1 UY2/K2 UR/K3 UR2 UB/K4 UB2A UG/K5 U1R/K8 U1B K9  
HJKT10 UDW2 314



Unless otherwise agreed in writing, this document is issued by the Company subject to its General Conditions of Service printed overleaf, available on request or accessible at <http://www.sgs.com/en/Terms-and-Conditions.aspx> and, for electronic format documents, subject to Terms and Conditions for Electronic Documents at <http://www.sgs.com/en/Terms-and-Conditions/Terms-e-Documents.aspx>. Attention is drawn to the limitation of liability, indemnification and jurisdiction issues defined therein. Any holder of this document is advised that information contained hereon reflects the Company's findings at the time of its intervention only and within the limits of Client's instructions, if any. The Company's sole responsibility is to its Client and this document does not exonerate parties to a transaction from exercising all their rights and obligations under the transaction documents. This document cannot be reproduced except in full, without prior written approval of the Company. Any unauthorized alteration, forgery or falsification of the content or appearance of this document is unlawful and offenders may be prosecuted to the fullest extent of the law. Unless otherwise stated the results shown in this test report refer only to the sample(s) tested.

Attention: To check the authenticity of testing /inspection report & certificate, please contact us at telephone: (86-755) 8307 1443, or email: [CN.Doccheck@sgs.com](mailto:CN.Doccheck@sgs.com)

SGS-CTC Standards Technical Services Co., Ltd 14/F West of Building 4, Lingyin Industry Park, No.1177 Lingyin Road, Ningbo National Hi-Tech Zone, Ningbo, Zhejiang, China 315040 T E&E (86-574)89070249 T ML (86-574)89070242 www.sgs.com.cn  
中国·浙江·宁波市国家高新区凌云路1177号凌云产业园4号楼西1-5层 邮编: 315040 T HL (86-574)89070271 T TY (86-574)89070211 e sgs.china@sgs.com

附件

RoHS 测试流程图

1) 样品按照下述流程被完全消解（六价铬和多溴联苯/多溴二苯醚测试除外）。

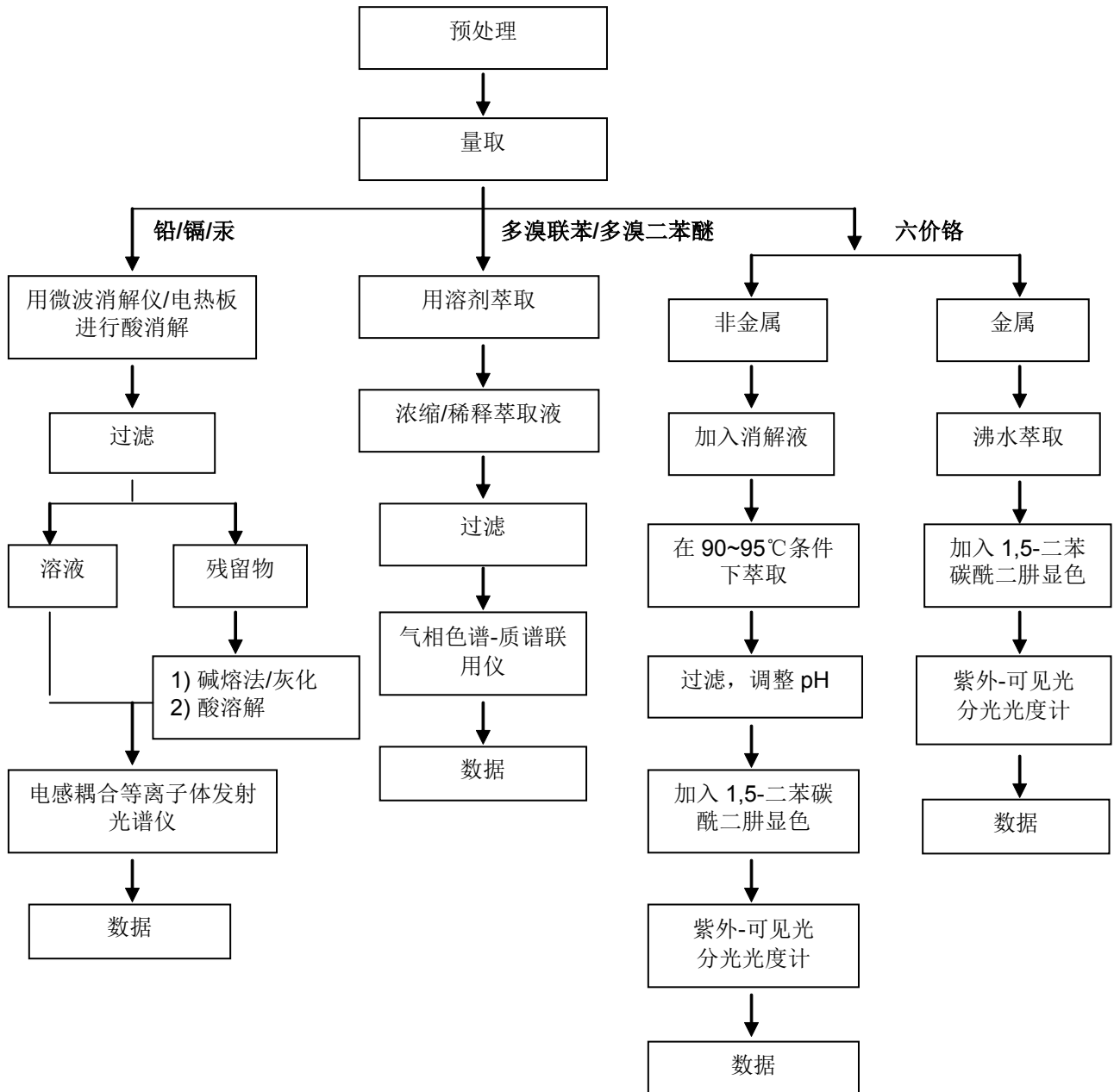

Unless otherwise agreed in writing, this document is issued by the Company subject to its General Conditions of Service printed overleaf, available on request or accessible at <http://www.sgs.com/en/Terms-and-Conditions.aspx> and, for electronic format documents, subject to Terms and Conditions for Electronic Documents at <http://www.sgs.com/en/Terms-and-Conditions/Terms-e-Documents.aspx>. Attention is drawn to the limitation of liability, indemnification and jurisdiction issues defined therein. Any holder of this document is advised that information contained hereon reflects the Company's findings at the time of its intervention only and within the limits of Client's instructions, if any. The Company's sole responsibility is to its Client and this document does not exonerate parties to a transaction from exercising all their rights and obligations under the transaction documents. This document cannot be reproduced except in full, without prior written approval of the Company. Any unauthorized alteration, forgery or falsification of the content or appearance of this document is unlawful and offenders may be prosecuted to the fullest extent of the law. Unless otherwise stated the results shown in this test report refer only to the sample(s) tested.

Attention: To check the authenticity of testing / inspection report & certificate, please contact us at telephone: (86-755) 8307 1443, or email: [CN.Doccheck@sgs.com](mailto:CN.Doccheck@sgs.com)

SGS-1602 Standards Technical Services Co., Ltd. 1-6/F West of Building 4, Lingyin Industry Park, No.1177 Lingyin Road, Ningbo National Hi-Tech Zone, Ningbo, Zhejiang, China 315040 T E&E (86-574)89070249 T ML (86-574)89070242 www.sgsgroup.com.cn  
 中国·浙江·宁波市国家高新区凌云路1177号凌云产业园4号楼西1-5层 邮编: 315040 T HL (86-574)89070271 T TY (86-574)89070211 e sgs.china@sgs.com



## 邻苯测试流程图

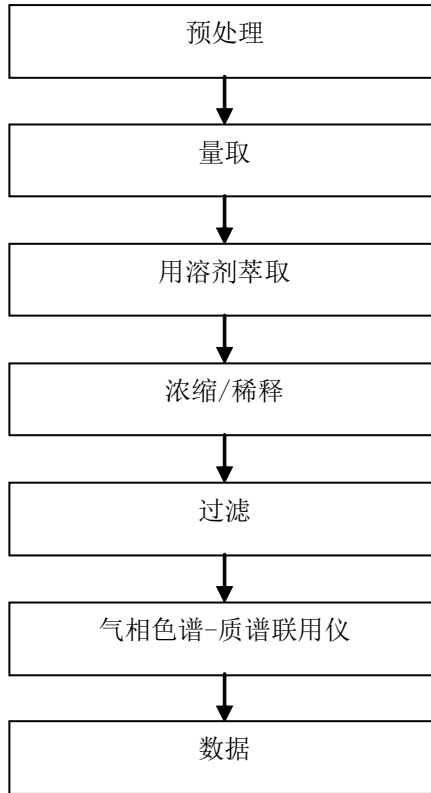

Unless otherwise agreed in writing, this document is issued by the Company subject to its General Conditions of Service printed overleaf, available on request or accessible at <http://www.sgs.com/en/Terms-and-Conditions.aspx> and, for electronic format documents, subject to Terms and Conditions for Electronic Documents at <http://www.sgs.com/en/Terms-and-Conditions/Terms-e-Documents.aspx>. Attention is drawn to the limitation of liability, indemnification and jurisdiction issues defined therein. Any holder of this document is advised that information contained hereon reflects the Company's findings at the time of its intervention only and within the limits of Client's instructions, if any. The Company's sole responsibility is to its Client and this document does not exonerate parties to a transaction from exercising all their rights and obligations under the transaction documents. This document cannot be reproduced except in full, without prior written approval of the Company. Any unauthorized alteration, forgery or falsification of the content or appearance of this document is unlawful and offenders may be prosecuted to the fullest extent of the law. Unless otherwise stated the results shown in this test report refer only to the sample(s) tested.

Attention: To check the authenticity of testing /inspection report & certificate, please contact us at telephone: (86-755) 8307 1443, or email: [CN.Doccheck@sgs.com](mailto:CN.Doccheck@sgs.com)

样品照片:

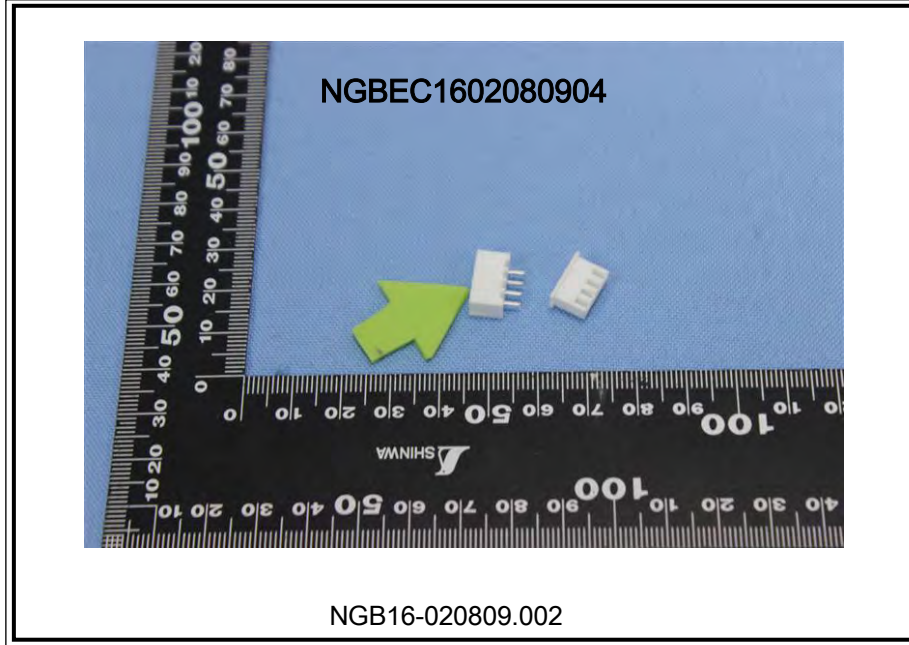

此照片仅限于随SGS正本报告使用

\*\*\* 报告完 \*\*\*



Unless otherwise agreed in writing, this document is issued by the Company subject to its General Conditions of Service printed overleaf, available on request or accessible at <http://www.sgs.com/en/Terms-and-Conditions.aspx> and, for electronic format documents, subject to Terms and Conditions for Electronic Documents at <http://www.sgs.com/en/Terms-and-Conditions/Terms-e-Documents.aspx>. Attention is drawn to the limitation of liability, indemnification and jurisdiction issues defined therein. Any holder of this document is advised that information contained hereon reflects the Company's findings at the time of its intervention only and within the limits of Client's instructions, if any. The Company's sole responsibility is to its Client and this document does not exonerate parties to a transaction from exercising all their rights and obligations under the transaction documents. This document cannot be reproduced except in full, without prior written approval of the Company. Any unauthorized alteration, forgery or falsification of the content or appearance of this document is unlawful and offenders may be prosecuted to the fullest extent of the law. Unless otherwise stated the results shown in this test report refer only to the sample(s) tested.

Attention: To check the authenticity of testing / inspection report & certificate, please contact us at telephone: (86-755) 8307 1443, or email: [CN.Doccheck@sgs.com](mailto:CN.Doccheck@sgs.com)

SGS Standards Technical Services Co., Ltd  
Ningbo Branch

14/F West of Building 4, Lingyin Industry Park, No.1177 Lingyin Road, Ningbo National Hi-Tech Zone, Ningbo, Zhejiang, China 315040  
中国·浙江·宁波市国家高新区凌云路1177号凌云产业园4号楼西1-5层

T E&E (86-574)89070249 T ML (86-574)89070242 www.sgsgroup.com.cn  
I HL (86-574)89070271 I TY (86-574)89070211 e sgs.china@sgs.com

**测试报告  
(SVHC)**

No. NGBEC1602081004

日期: 2016年05月24日 第1页,共16页

以下测试之样品是由申请者所提供及确认: 连接器

SGS工作编号: NP16-001905 - NB

主要成分: 尼龙66

铜,锡

料号: A2501

型号: XH

客户参考信息: 见附件

样品接收日期: 2016年05月16日

测试周期: 2016年05月16日 - 2016年05月20日

测试要求: 根据客户要求,

(i) 对于样品002, 基于欧洲化学品管理署截止2015年12月17日公布的供授权审议的高关注物质候选清单(根据欧盟第1907/2006号REACH法规), 对168种高关注物质(SVHC)进行筛分测试。

(ii) 对于样品003, 基于欧洲化学品管理署截止2015年12月17日公布的供授权审议的高关注物质候选清单(根据欧盟第1907/2006号REACH法规), 对55种无机高关注物质(SVHC)进行筛分测试。

测试结果: 请参见下一页

总结:

|   |    |
|---|----|
| 根据具体的测试范围和分析技术, 委托样品中测试的高关注物质浓度都 $\leq$ 0.1%。 | 通过 |
|---|----|

通标标准技术服务有限公司宁波分公司  
授权签名



Iris Xiao 肖玲艳  
批准签署人

本报告是编号为NGBEC1602081003报告的中文版本



Unless otherwise agreed in writing, this document is issued by the Company subject to its General Conditions of Service printed overleaf, available on request or accessible at <http://www.sgs.com/en/Terms-and-Conditions.aspx> and, for electronic format documents, subject to Terms and Conditions for Electronic Documents at <http://www.sgs.com/en/Terms-and-Conditions/Terms-e-Documents.aspx>. Attention is drawn to the limitation of liability, indemnification and jurisdiction issues defined therein. Any holder of this document is advised that information contained hereon reflects the Company's findings at the time of its intervention only and within the limits of Client's instructions, if any. The Company's sole responsibility is to its Client and this document does not exonerate parties to a transaction from exercising all their rights and obligations under the transaction documents. This document cannot be reproduced except in full, without prior written approval of the Company. Any unauthorized alteration, forgery or falsification of the content or appearance of this document is unlawful and offenders may be prosecuted to the fullest extent of the law. Unless otherwise stated the results shown in this test report refer only to the sample(s) tested.

Attention: To check the authenticity of testing /inspection report & certificate, please contact us at telephone: (86-755) 8307 1443, or email: [CN.Doccheck@sgs.com](mailto:CN.Doccheck@sgs.com)

SGS-1602 Standards Technical Services Co., Ltd. 14/F West of Building 4, Lingyin Industry Park, No.1177 Lingyin Road, Ningbo National Hi-Tech Zone, Ningbo, Zhejiang, China 315040 T E&E (86-574)89070249 T ML (86-574)89070242 www.sgs.com.cn  
中国·浙江·宁波市国家高新区凌云路1177号凌云产业园4号楼西1-5层 邮编: 315040 T HL (86-574)89070271 T TY (86-574)89070211 e [sgs.china@sgs.com](mailto:sgs.china@sgs.com)

## 测试报告 (SVHC)

No. NGBEC1602081004

日期: 2016年05月24日 第2页,共16页

备注:

- (1) 本报告所涉及的关于特定高关注物质的化学分析是根据欧洲化学品管理署发布的下列文件, 利用现有的分析技术完成的。

<http://echa.europa.eu/web/guest/candidate-list-table>

这些文件清单由欧洲化学品管理署评估, 将来可能会有变化。

- (2) 关于物品:

根据欧盟第1907/2006 (EC) 号法规, 如果满足以下两个条件, 如果物质符合第57条中的标准并根据第59条第一款被确定, 物品的任何欧洲制造商或进口商应根据第7条第4款向欧盟化学品管理署进行通报: (a) 候选清单中的物质在物品中的总含量超过1吨/年/生产商或进口商; (b) 候选清单中的物质在物品中的总含量以质量分数计超过0.1% 的浓度。

欧盟第1907/2006 (EC) 号法规第33条规定, 含有满足第57条中的标准并根据第59条第一款被确定且质量分数大于0.1%的物质的物品的所有供应商应向物品接受者提供其可获取的充足信息, 以使物品使用安全, 这些信息至少包括含有的候选清单中物质的名称。

SGS采用ECHA对物品中SVHC的解释, 除非另有说明。详细的解释请见下列网址:

[http://webstage.contribute.sgs.net/corpreach/documents/SGS-CTS\\_SVHC-paper-EN-11.pdf](http://webstage.contribute.sgs.net/corpreach/documents/SGS-CTS_SVHC-paper-EN-11.pdf)

- (3) 关于材料:

报告中的测试结果是基于测试样品。如样品是均一材质, 当其构成成品时, 此结果不能代表成品中的SVHC浓度。如样品为均一材质等比例合测, 这些材质也可能来自不同的物品。

如果样品是一种物质或混合物, 并且直接出口到欧盟, 客户有责任遵守欧盟第1907/2006号REACH法规第31条供应链信息传递的义务和附件十四中的授权高关注物质授权的责任。

- (4) 关于物质和配制品:

如果样品中高关注物质的浓度超过0.1% (w/w) 和/或欧盟第1272/2008号CLP法规和欧盟委员会条例第790/2009号中设定的特殊浓度限值, 建议客户根据欧盟第1907/2006号REACH法规对有关高关注物质准备安全数据表(SDS)以符合供应链传递信息的义务, 如:

- 根据欧盟第1272/2008号CLP法规被列为有害物质。

- 根据危险混合物指令1999/45/EC或欧盟第1272/2008号CLP法规被列为危险混合物, 而其浓度大于或等于危险混合物指令1999/45/EC第3条(3)中规定的限制数值或欧盟第1272/2008号CLP法规附件六第3部分列出的较低值;或

- 根据危险混合物指令1999/45/EC并未列为危险混合物, 但包含:

(a) 对人类健康或环境有害的物质, 而在固体或液体混合物 (即非气体混合物) 中其浓度 $\geq 1\%$  (w/w) 或在气体混合物中占体积 $\geq 0.2\%$ , 或

(b) PBT或vPvB物质, 在固体或液体混合物 (即非气体混合物) 中浓度 $\geq 0.1\%$  (w/w), 或

(c) 授权审议的高关注物质候选清单上的物质 (除上述以外的原因) 在非气体混合物中的浓度 $\geq 0.1\%$  (w/w), 或



Unless otherwise agreed in writing, this document is issued by the Company subject to its General Conditions of Service printed overleaf, available on request or accessible at <http://www.sgs.com/en/Terms-and-Conditions.aspx> and, for electronic format documents, subject to Terms and Conditions for Electronic Documents at <http://www.sgs.com/en/Terms-and-Conditions/Terms-e-Documents.aspx>. Attention is drawn to the limitation of liability, indemnification and jurisdiction issues defined therein. Any holder of this document is advised that information contained hereon reflects the Company's findings at the time of its intervention only and within the limits of Client's instructions, if any. The Company's sole responsibility is to its Client and this document does not exonerate parties to a transaction from exercising all their rights and obligations under the transaction documents. This document cannot be reproduced except in full, without prior written approval of the Company. Any unauthorized alteration, forgery or falsification of the content or appearance of this document is unlawful and offenders may be prosecuted to the fullest extent of the law. Unless otherwise stated the results shown in this test report refer only to the sample(s) tested.

Attention: To check the authenticity of testing / inspection report & certificate, please contact us at telephone: (86-755) 8307 1443, or email: [CN.Doccheck@sgs.com](mailto:CN.Doccheck@sgs.com)

SGS-CTC Standards Technical Services Co., Ltd  
Ningbo Branch

14/F West of Building 4, Lingyin Industry Park, No.1177 Lingyin Road, Ningbo National Hi-Tech Zone, Ningbo, Zhejiang, China 315040 TEL: (86-574)89070249 TML: (86-574)89070242 www.sgs.com.cn  
中国·浙江·宁波市国家高新区凌云路1177号凌云产业园4号楼西1-5层 邮编: 315040 IHL: (86-574)89070271 ITY: (86-574)89070211 e: [sgs.china@sgs.com](mailto:sgs.china@sgs.com)

# 测试报告 (SVHC)

No. NGBEC1602081004

日期: 2016年05月24日 第3页,共16页

(d) 设有欧洲范围内工作场所接触限值的物质。

(5) 如果样品中SVHC的测试结果超过报告限, 建议客户进一步定量分析检测含有SVHC的组分并且得到SVHC物质的准确浓度。

## 测试样品:

### 测试样品描述:

| 样品编号 | SGS样品ID          | 描述   | 测试SVHC数目 |
|------|------------------|------|----------|
| SN1  | NGB16-020810.002 | 白色塑料 | 168      |
| SN2  | NGB16-020810.003 | 银色金属 | 55       |

## 测试方法:

SGS内部方法-NBCHEM-TOP-138, NBCHEM-TOP-124, 采用 ICP-OES、UV-VIS、GC-MS、HPLC-DAD/MS 和比色法分析。



Unless otherwise agreed in writing, this document is issued by the Company subject to its General Conditions of Service printed overleaf, available on request or accessible at <http://www.sgs.com/en/Terms-and-Conditions.aspx> and, for electronic format documents, subject to Terms and Conditions for Electronic Documents at <http://www.sgs.com/en/Terms-and-Conditions/Terms-e-Documents.aspx>. Attention is drawn to the limitation of liability, indemnification and jurisdiction issues defined therein. Any holder of this document is advised that information contained hereon reflects the Company's findings at the time of its intervention only and within the limits of Client's instructions, if any. The Company's sole responsibility is to its Client and this document does not exonerate parties to a transaction from exercising all their rights and obligations under the transaction documents. This document cannot be reproduced except in full, without prior written approval of the Company. Any unauthorized alteration, forgery or falsification of the content or appearance of this document is unlawful and offenders may be prosecuted to the fullest extent of the law. Unless otherwise stated the results shown in this test report refer only to the sample(s) tested.

Attention: To check the authenticity of testing / inspection report & certificate, please contact us at telephone: (86-755) 8307 1443, or email: [CN.Doccheck@sgs.com](mailto:CN.Doccheck@sgs.com)

SGS-CTC Standards Technical Services Co., Ltd 14/F West of Building 4, Lingyin Industry Park, No.1177 Lingyin Road, Ningbo National Hi-Tech Zone, Ningbo, Zhejiang, China 315040 T E&E (86-574)89070249 T ML (86-574)89070242 www.sgs.com.cn  
 中国·浙江·宁波市国家高新区凌云路1177号凌云产业园4号楼西1-5层 邮编: 315040 T HL (86-574)89070271 T TY (86-574)89070211 e sgs.china@sgs.com

# 测试报告 (SVHC)

No. NGBEC1602081004

日期: 2016年05月24日 第4页,共16页

## 测试结果: (SVHC候选清单中的高关注物质)

| 批次 | 物质名称            | CAS No. | 002<br>浓度 (%) | RL (%) |
|----|-----------------|---------|---------------|--------|
| -  | 所有测试的候选清单中的SVHC | -       | ND            | -      |

## 测试结果: (SVHC候选清单中的高关注物质)

| 批次 | 物质名称            | CAS No. | 003<br>浓度 (%) | RL (%) |
|----|-----------------|---------|---------------|--------|
| -  | 所有测试的候选清单中的SVHC | -       | ND            | -      |

### 注释:

- (1) 上表仅显示检出的SVHC, 低于RL的SVHC没有列出。所有测试的SVHC请参见附录
- (2) RL = 报告极限值, 所有RL是基于均一材质的测试。  
ND = 未检出 (< RL), ND针对SVHC物质。
- (3)  $\Delta$ 六溴环十二烷(HBCDD) 的非对映异构体 $\alpha$ -HBCDD、 $\beta$ -HBCDD、 $\gamma$ -HBCDD的CAS NO分别为 134237-50-6, 134237-51-7, 134237-52-8。  
☆甲基六氢邻苯二甲酸酐, 4-甲基六氢邻苯二甲酸酐, 1-甲基六氢邻苯二甲酸酐, 3-甲基六氢邻苯二甲酸酐的CAS No: 25550-51-0, 19438-60-9, 48122-14-1, 57110-29-9; 及其EC No: 247-094-1, 243-072-0, 256-356-4, 260-566-1。
- (4) \* 测试结果是由选定的元素或标记物的结果并基于最坏的情况计算得出。详细信息请参见SGS REACH 网站: [www.reach.sgs.com/substance-of-very-high-concern-analysis-information-page.htm](http://www.reach.sgs.com/substance-of-very-high-concern-analysis-information-page.htm)  
硼化合物的结果由ICP-OES测试的总硼(液体, 粉末, 膏体类样品)和水提取(其他样品)的硼元素结果换算得出。  
RL = 0.005% 是针对元素(例如钴、砷、铅、铬(VI)、铝、镉、硼、锶、锌、铈、钛、钡和镉), 除了钼的RL= 0.0005%, 硼的RL= 0.0025%(仅对四氟硼酸铅)。
- (5) § 只有当物质包含米氏酮(CAS No.: 90-94-8)或米氏碱(CAS No.: 101-61-1)的浓度 $\geq 0.1\%(w/w)$ 的情况下, 该物质才被提议定为SVHC。



Unless otherwise agreed in writing, this document is issued by the Company subject to its General Conditions of Service printed overleaf, available on request or accessible at <http://www.sgs.com/en/Terms-and-Conditions.aspx> and, for electronic format documents, subject to Terms and Conditions for Electronic Documents at <http://www.sgs.com/en/Terms-and-Conditions/Terms-e-Documents.aspx>. Attention is drawn to the limitation of liability, indemnification and jurisdiction issues defined therein. Any holder of this document is advised that information contained hereon reflects the Company's findings at the time of its intervention only and within the limits of Client's instructions, if any. The Company's sole responsibility is to its Client and this document does not exonerate parties to a transaction from exercising all their rights and obligations under the transaction documents. This document cannot be reproduced except in full, without prior written approval of the Company. Any unauthorized alteration, forgery or falsification of the content or appearance of this document is unlawful and offenders may be prosecuted to the fullest extent of the law. Unless otherwise stated the results shown in this test report refer only to the sample(s) tested.

Attention: To check the authenticity of testing / inspection report & certificate, please contact us at telephone: (86-755) 8307 1443, or email: [CN.Doccheck@sgs.com](mailto:CN.Doccheck@sgs.com)

14/F West of Building 4, Lingyin Industry Park, No.1177 Lingyin Road, Ningbo National Hi-Tech Zone, Ningbo, Zhejiang, China 315040 T E&E (86-574)89070249 T ML (86-574)89070242 www.sgsgroup.com.cn  
中国·浙江·宁波市国家高新区凌云路1177号凌云产业园4号楼西1-5层 邮编: 315040 T HL (86-574)89070271 T TY (86-574)89070211 e [sgs.china@sgs.com](mailto:sgs.china@sgs.com)

# 测试报告 (SVHC)

No. NGBEC1602081004

日期: 2016年05月24日 第5页,共16页

附录

所有测试的SVHC:

| 批次 | 序号 | 物质名称   | CAS No.                  | RL (%) | 样品ID    |
|----|----|--|--------------------------|--------|---------|
| I  | 1  | 4,4'-二氨基二苯甲烷(MDA)  | 101-77-9                 | 0.050  | 002     |
| I  | 2  | 2,4,6-三硝基-5-叔丁基间二甲苯(二甲苯麝香)   | 81-15-2                  | 0.050  | 002     |
| I  | 3  | C10-13 氯代烃(短链氯化石蜡)   | 85535-84-8               | 0.050  | 002     |
| I  | 4  | 蒽  | 120-12-7                 | 0.050  | 002     |
| I  | 5  | 邻苯二甲酸丁苄酯(BBP)  | 85-68-7                  | 0.050  | 002     |
| I  | 6  | 邻苯二甲酸二(2-乙基己基)酯(DEHP)  | 117-81-7                 | 0.050  | 002     |
| I  | 7  | 氧化双三丁基锡(TBTO)  | 56-35-9                  | 0.050  | 002     |
| I  | 8  | 二氯化钴*  | 7646-79-9                | 0.005  | 002,003 |
| I  | 9  | 五氧化二砷*   | 1303-28-2                | 0.005  | 002,003 |
| I  | 10 | 三氧化二砷*   | 1327-53-3                | 0.005  | 002,003 |
| I  | 11 | 邻苯二甲酸二丁酯(DBP)  | 84-74-2                  | 0.050  | 002     |
| I  | 12 | 六溴环十二烷(HBCDD) 及其非对映异构体( $\alpha$ -HBCDD, $\beta$ -HBCDD, $\gamma$ -HBCDD) $\Delta$ | 25637-99-4,<br>3194-55-6 | 0.050  | 002     |
| I  | 13 | 砷酸氢铅*  | 7784-40-9                | 0.005  | 002,003 |
| I  | 14 | 重铬酸钠*  | 7789-12-0,<br>10588-01-9 | 0.005  | 002,003 |
| I  | 15 | 三乙基磷酸酯*  | 15606-95-8               | 0.005  | 002     |
| II | 16 | 2,4-二硝基甲苯  | 121-14-2                 | 0.050  | 002     |
| II | 17 | 丙烯酰胺   | 79-06-1                  | 0.050  | 002     |
| II | 18 | 蒽油*  | 90640-80-5               | 0.050  | 002     |
| II | 19 | 蒽油, 蒽糊*  | 90640-81-6               | 0.050  | 002     |
| II | 20 | 蒽油, 蒽糊, 蒽馏分*   | 91995-15-2               | 0.050  | 002     |



Unless otherwise agreed in writing, this document is issued by the Company subject to its General Conditions of Service printed overleaf, available on request or accessible at <http://www.sgs.com/en/Terms-and-Conditions.aspx> and, for electronic format documents, subject to Terms and Conditions for Electronic Documents at <http://www.sgs.com/en/Terms-and-Conditions/Terms-e-Documents.aspx>. Attention is drawn to the limitation of liability, indemnification and jurisdiction issues defined therein. Any holder of this document is advised that information contained hereon reflects the Company's findings at the time of its intervention only and within the limits of Client's instructions, if any. The Company's sole responsibility is to its Client and this document does not exonerate parties to a transaction from exercising all their rights and obligations under the transaction documents. This document cannot be reproduced except in full, without prior written approval of the Company. Any unauthorized alteration, forgery or falsification of the content or appearance of this document is unlawful and offenders may be prosecuted to the fullest extent of the law. Unless otherwise stated the results shown in this test report refer only to the sample(s) tested.

Attention: To check the authenticity of testing / inspection report & certificate, please contact us at telephone: (86-755) 8307 1443, or email: [CN.Doccheck@sgs.com](mailto:CN.Doccheck@sgs.com)

SGS-20 Standards Technical Services Co., Ltd  
Ningbo Branch

14/F West of Building 4, Lingyin Industry Park, No.1177 Lingyin Road, Ningbo National Hi-Tech Zone, Ningbo, Zhejiang, China 315040 1 E&E (86-574)89070249 1 ML (86-574)89070242 www.sgsgroup.com.cn  
中国·浙江·宁波市国家高新区凌云路1177号凌云产业园4号楼西1-5层 邮编: 315040 1 HL (86-574)89070271 1 TY (86-574)89070211 e [sgs.china@sgs.com](mailto:sgs.china@sgs.com)

测试报告  
(SVHC)

No. NGBEC1602081004

日期: 2016年05月24日 第6页,共16页

附录

所有测试的SVHC:

| 批次  | 序号 | 物质名称                      | CAS No.                                | RL (%) | 样品ID    |
|-----|----|---------------------------|--|--------|---------|
| II  | 21 | 葱油, 葱糊, 轻油*               | 91995-17-4                             | 0.050  | 002     |
| II  | 22 | 葱油, 含葱量少*                 | 90640-82-7                             | 0.050  | 002     |
| II  | 23 | 邻苯二甲酸二异丁酯                 | 84-69-5                                | 0.050  | 002     |
| II  | 24 | 铬酸铅*                      | 7758-97-6                              | 0.005  | 002,003 |
| II  | 25 | 钼铬红(C.I.颜料红104)*          | 12656-85-8                             | 0.005  | 002,003 |
| II  | 26 | 铅铬黄(C.I.颜料黄34)*           | 1344-37-2                              | 0.005  | 002,003 |
| II  | 27 | 沥青, 煤焦油, 高温*              | 65996-93-2                             | 0.050  | 002     |
| II  | 28 | 磷酸三(2-氯乙基)酯               | 115-96-8                               | 0.050  | 002     |
| III | 29 | 重铬酸铵*                     | 7789-09-5                              | 0.005  | 002,003 |
| III | 30 | 硼酸*                       | 10043-35-3,<br>11113-50-1              | 0.005  | 002,003 |
| III | 31 | 无水四硼酸钠*                   | 1303-96-4,<br>1330-43-4,<br>12179-04-3 | 0.005  | 002,003 |
| III | 32 | 铬酸钾*                      | 7789-00-6                              | 0.005  | 002,003 |
| III | 33 | 重铬酸钾*                     | 7778-50-9                              | 0.005  | 002,003 |
| III | 34 | 铬酸钠*                      | 7775-11-3                              | 0.005  | 002,003 |
| III | 35 | 水合硼酸钠*                    | 12267-73-1                             | 0.005  | 002,003 |
| III | 36 | 三氯乙烯                      | 79-01-6                                | 0.050  | 002     |
| IV  | 37 | 乙二醇乙醚                     | 110-80-5                               | 0.050  | 002     |
| IV  | 38 | 乙二醇单甲醚                    | 109-86-4                               | 0.050  | 002     |
| IV  | 39 | 铬酸,<br>铬酸及重铬酸低聚物,<br>重铬酸* | 7738-94-5<br>-<br>13530-68-2           | 0.005  | 002,003 |



Unless otherwise agreed in writing, this document is issued by the Company subject to its General Conditions of Service printed overleaf, available on request or accessible at <http://www.sgs.com/en/Terms-and-Conditions.aspx> and, for electronic format documents, subject to Terms and Conditions for Electronic Documents at <http://www.sgs.com/en/Terms-and-Conditions/Terms-e-Documents.aspx>. Attention is drawn to the limitation of liability, indemnification and jurisdiction issues defined therein. Any holder of this document is advised that information contained hereon reflects the Company's findings at the time of its intervention only and within the limits of Client's instructions, if any. The Company's sole responsibility is to its Client and this document does not exonerate parties to a transaction from exercising all their rights and obligations under the transaction documents. This document cannot be reproduced except in full, without prior written approval of the Company. Any unauthorized alteration, forgery or falsification of the content or appearance of this document is unlawful and offenders may be prosecuted to the fullest extent of the law. Unless otherwise stated the results shown in this test report refer only to the sample(s) tested.

Attention: To check the authenticity of testing / inspection report & certificate, please contact us at telephone: (86-755) 8307 1443, or email: [CN.Doccheck@sgs.com](mailto:CN.Doccheck@sgs.com)

SGS Standards Technical Services Co., Ltd  
Ningbo Branch

14/F West of Building 4, Lingyin Industry Park, No.1177 Lingyin Road, Ningbo National Hi-Tech Zone, Ningbo, Zhejiang, China 315040 T E&E (86-574)89070249 T ML (86-574)89070242 www.sgsgroup.com.cn  
中国·浙江·宁波市国家高新区凌云路1177号凌云产业园4号楼西1-5层 邮编: 315040 T HL (86-574)89070271 T TY (86-574)89070211 e sgs.china@sgs.com



# 测试报告 (SVHC)

No. NGBEC1602081004

日期: 2016年05月24日 第7页,共16页

附录

所有测试的SVHC:

| 批次 | 序号 | 物质名称                        | CAS No.                     | RL (%) | 样品ID    |
|----|----|-----------------------------|-----------------------------|--------|---------|
| IV | 40 | 三氧化铬*                       | 1333-82-0                   | 0.005  | 002,003 |
| IV | 41 | 碳酸钴*                        | 513-79-1                    | 0.005  | 002,003 |
| IV | 42 | 乙酸钴*                        | 71-48-7                     | 0.005  | 002     |
| IV | 43 | 硝酸钴*                        | 10141-05-6                  | 0.005  | 002,003 |
| IV | 44 | 硫酸钴*                        | 10124-43-3                  | 0.005  | 002,003 |
| V  | 45 | 1,2,3-三氯丙烷                  | 96-18-4                     | 0.050  | 002     |
| V  | 46 | 1,2-苯二酸-二(C6-8支链)烷基酯(富C7)   | 71888-89-6                  | 0.050  | 002     |
| V  | 47 | 1,2-苯二酸-二(C7-11支链与直链)烷基(醇)酯 | 68515-42-4                  | 0.050  | 002     |
| V  | 48 | 1-甲基-2-吡咯烷酮                 | 872-50-4                    | 0.050  | 002     |
| V  | 49 | 乙二醇乙醚醋酸酯                    | 111-15-9                    | 0.050  | 002     |
| V  | 50 | 联氨                          | 7803-57-8,<br>302-01-2      | 0.050  | 002     |
| V  | 51 | 铬酸锶*                        | 7789-06-2                   | 0.005  | 002,003 |
| VI | 52 | 1,2-二氯乙烷                    | 107-06-2                    | 0.050  | 002     |
| VI | 53 | 4,4'-二氨基-3,3'-二氯二苯甲烷        | 101-14-4                    | 0.050  | 002     |
| VI | 54 | 2-甲氧基苯胺                     | 90-04-0                     | 0.050  | 002     |
| VI | 55 | 对特辛基苯酚                      | 140-66-9                    | 0.050  | 002     |
| VI | 56 | 硅酸铝耐火陶瓷纤维*                  | 650-017-00-8<br>(Index no.) | 0.005  | 002,003 |
| VI | 57 | 砷酸*                         | 7778-39-4                   | 0.005  | 002,003 |
| VI | 58 | 二乙二醇二甲醚                     | 111-96-6                    | 0.050  | 002     |
| VI | 59 | 邻苯二甲酸二甲氧基乙酯                 | 117-82-8                    | 0.050  | 002     |



Unless otherwise agreed in writing, this document is issued by the Company subject to its General Conditions of Service printed overleaf, available on request or accessible at <http://www.sgs.com/en/Terms-and-Conditions.aspx> and, for electronic format documents, subject to Terms and Conditions for Electronic Documents at <http://www.sgs.com/en/Terms-and-Conditions/Terms-e-Documents.aspx>. Attention is drawn to the limitation of liability, indemnification and jurisdiction issues defined therein. Any holder of this document is advised that information contained hereon reflects the Company's findings at the time of its intervention only and within the limits of Client's instructions, if any. The Company's sole responsibility is to its Client and this document does not exonerate parties to a transaction from exercising all their rights and obligations under the transaction documents. This document cannot be reproduced except in full, without prior written approval of the Company. Any unauthorized alteration, forgery or falsification of the content or appearance of this document is unlawful and offenders may be prosecuted to the fullest extent of the law. Unless otherwise stated the results shown in this test report refer only to the sample(s) tested.

Attention: To check the authenticity of testing / inspection report & certificate, please contact us at telephone: (86-755) 8307 1443, or email: [CN.Doccheck@sgs.com](mailto:CN.Doccheck@sgs.com)

SGS-20 Standards Technical Services Co., Ltd  
Ningbo Branch

14/F West of Building 4, Lingyin Industry Park, No.1177 Lingyin Road, Ningbo National Hi-Tech Zone, Ningbo, Zhejiang, China 315040  
中国·浙江·宁波市国家高新区凌云路1177号凌云产业园4号楼西1-5层

1 E&E (86-574)89070249 1 ML (86-574)89070242 www.sgsgroup.com.cn  
邮编: 315040 1 HL (86-574)89070271 1 TY (86-574)89070211 e sgs.china@sgs.com

# 测试报告 (SVHC)

No. NGBEC1602081004

日期: 2016年05月24日 第8页,共16页

附录

所有测试的SVHC:

| 批次  | 序号 | 物质名称                      | CAS No.                     | RL (%) | 样品ID    |
|-----|----|---------------------------|-----------------------------|--------|---------|
| VI  | 60 | 砷酸钙*                      | 7778-44-1                   | 0.005  | 002,003 |
| VI  | 61 | 铬酸铬*                      | 24613-89-6                  | 0.005  | 002,003 |
| VI  | 62 | 甲醛与苯胺的低聚物                 | 25214-70-4                  | 0.050  | 002     |
| VI  | 63 | 叠氮化铅*                     | 13424-46-9                  | 0.005  | 002,003 |
| VI  | 64 | 苦味酸铅*                     | 6477-64-1                   | 0.005  | 002     |
| VI  | 65 | 史蒂芬酸铅*                    | 15245-44-0                  | 0.005  | 002     |
| VI  | 66 | N,N-二甲基乙酰胺                | 127-19-5                    | 0.050  | 002     |
| VI  | 67 | 氢氧化铬酸锌*                   | 49663-84-5                  | 0.005  | 002,003 |
| VI  | 68 | 酚酞                        | 77-09-8                     | 0.050  | 002     |
| VI  | 69 | 氢氧化铬酸锌钾*                  | 11103-86-9                  | 0.005  | 002,003 |
| VI  | 70 | 砷酸铅*                      | 3687-31-8                   | 0.005  | 002,003 |
| VI  | 71 | 氧化锆硅酸铝耐火陶瓷纤维*             | 650-017-00-8<br>(Index no.) | 0.005  | 002,003 |
| VII | 72 | C.I.碱性蓝26§                | 2580-56-5                   | 0.050  | 002     |
| VII | 73 | C.I.碱性紫3§                 | 548-62-9                    | 0.050  | 002     |
| VII | 74 | 三乙二醇二甲醚(TEGDME)           | 112-49-2                    | 0.050  | 002     |
| VII | 75 | 乙二醇二甲醚(EGDME)             | 110-71-4                    | 0.050  | 002     |
| VII | 76 | 4,4'-二(二甲氨基)二苯甲酮(米氏酮)     | 90-94-8                     | 0.050  | 002     |
| VII | 77 | 4,4'-二(二甲氨基)-4''-甲氨基三苯甲醇§ | 561-41-1                    | 0.050  | 002     |
| VII | 78 | 三氧化二硼*                    | 1303-86-2                   | 0.005  | 002,003 |
| VII | 79 | 甲酰胺                       | 75-12-7                     | 0.050  | 002     |



Unless otherwise agreed in writing, this document is issued by the Company subject to its General Conditions of Service printed overleaf, available on request or accessible at <http://www.sgs.com/en/Terms-and-Conditions.aspx> and, for electronic format documents, subject to Terms and Conditions for Electronic Documents at <http://www.sgs.com/en/Terms-and-Conditions/Terms-e-Documents.aspx>. Attention is drawn to the limitation of liability, indemnification and jurisdiction issues defined therein. Any holder of this document is advised that information contained hereon reflects the Company's findings at the time of its intervention only and within the limits of Client's instructions, if any. The Company's sole responsibility is to its Client and this document does not exonerate parties to a transaction from exercising all their rights and obligations under the transaction documents. This document cannot be reproduced except in full, without prior written approval of the Company. Any unauthorized alteration, forgery or falsification of the content or appearance of this document is unlawful and offenders may be prosecuted to the fullest extent of the law. Unless otherwise stated the results shown in this test report refer only to the sample(s) tested.

Attention: To check the authenticity of testing / inspection report & certificate, please contact us at telephone: (86-755) 8307 1443, or email: [CN.Doccheck@sgs.com](mailto:CN.Doccheck@sgs.com)

SGS-20 Standards Technical Services Co., Ltd  
Ningbo Branch

14/F West of Building 4, Lingyin Industry Park, No.1177 Lingyin Road, Ningbo National Hi-Tech Zone, Ningbo, Zhejiang, China 315040 T E&E (86-574)89070249 T ML (86-574)89070242 www.sgsgroup.com.cn  
中国·浙江·宁波市国家高新区凌云路1177号凌云产业园4号楼西1-5层 邮编: 315040 T HL (86-574)89070271 T TY (86-574)89070211 e [sgs.china@sgs.com](mailto:sgs.china@sgs.com)

# 测试报告 (SVHC)

No. NGBEC1602081004

日期: 2016年05月24日 第9页,共16页

附录

所有测试的SVHC:

| 批次   | 序号 | 物质名称  | CAS No.     | RL (%) | 样品ID |
|------|----|---|-------------|--------|------|
| VII  | 80 | 甲基磺酸铅*  | 17570-76-2  | 0.005  | 002  |
| VII  | 81 | N,N,N',N'-四甲基-4,4'-二氨基二苯甲烷(米氏碱)   | 101-61-1    | 0.050  | 002  |
| VII  | 82 | 1,3,5-三(环氧乙基甲基)-1,3,5-三嗪-2,4,6-(1H, 3H,5H)-三酮(TGIC)                       | 2451-62-9   | 0.050  | 002  |
| VII  | 83 | C.I.溶剂蓝4§   | 6786-83-0   | 0.050  | 002  |
| VII  | 84 | 1,3,5-三-[(2S和2R)-2,3-环氧丙基]-1,3,5-三嗪-2,4,6-(1H, 3H, 5H)-三酮( $\beta$ -TGIC) | 59653-74-6  | 0.050  | 002  |
| VIII | 85 | 二盐基邻苯二甲酸铅*  | 69011-06-9  | 0.005  | 002  |
| VIII | 86 | 1,2-苯二酸-二(支链与直链)戊基酯   | 84777-06-0  | 0.050  | 002  |
| VIII | 87 | 乙二醇二乙醚  | 629-14-1    | 0.050  | 002  |
| VIII | 88 | 1-溴丙烷   | 106-94-5    | 0.050  | 002  |
| VIII | 89 | 3-乙基-2-甲基-2-(3-甲基丁基)-1,3-恶唑烷  | 143860-04-2 | 0.050  | 002  |
| VIII | 90 | 对特辛基苯酚乙氧基醚  | -           | 0.050  | 002  |
| VIII | 91 | 4,4'-二氨基-3,3'-二甲基二苯甲烷   | 838-88-0    | 0.050  | 002  |
| VIII | 92 | 4,4'-二氨基二苯醚及其盐  | 101-80-4    | 0.050  | 002  |
| VIII | 93 | 4-氨基偶氮苯   | 60-09-3     | 0.050  | 002  |
| VIII | 94 | 2,4-二氨基甲苯   | 95-80-7     | 0.050  | 002  |
| VIII | 95 | 4-壬基(支链与直链)苯酚   | -           | 0.050  | 002  |
| VIII | 96 | 2-甲氧基-5-甲基苯胺  | 120-71-8    | 0.050  | 002  |
| VIII | 97 | 碱式乙酸铅*  | 51404-69-4  | 0.005  | 002  |
| VIII | 98 | 4-氨基联苯  | 92-67-1     | 0.050  | 002  |
| VIII | 99 | 十溴二苯醚(DecaBDE)  | 1163-19-5   | 0.050  | 002  |



Unless otherwise agreed in writing, this document is issued by the Company subject to its General Conditions of Service printed overleaf, available on request or accessible at <http://www.sgs.com/en/Terms-and-Conditions.aspx> and, for electronic format documents, subject to Terms and Conditions for Electronic Documents at <http://www.sgs.com/en/Terms-and-Conditions/Terms-e-Documents.aspx>. Attention is drawn to the limitation of liability, indemnification and jurisdiction issues defined therein. Any holder of this document is advised that information contained hereon reflects the Company's findings at the time of its intervention only and within the limits of Client's instructions, if any. The Company's sole responsibility is to its Client and this document does not exonerate parties to a transaction from exercising all their rights and obligations under the transaction documents. This document cannot be reproduced except in full, without prior written approval of the Company. Any unauthorized alteration, forgery or falsification of the content or appearance of this document is unlawful and offenders may be prosecuted to the fullest extent of the law. Unless otherwise stated the results shown in this test report refer only to the sample(s) tested.

Attention: To check the authenticity of testing /inspection report & certificate, please contact us at telephone: (86-755) 8307 1443, or email: [CN.Doccheck@sgs.com](mailto:CN.Doccheck@sgs.com)

14/F West of Building 4, Lingyin Industry Park, No.1177 Lingyin Road, Ningbo National Hi-Tech Zone, Ningbo, Zhejiang, China 315040 T E&E (86-574)89070249 T ML (86-574)89070242 www.sgsgroup.com.cn  
中国·浙江·宁波市国家高新区凌云路1177号凌云产业园4号楼西1-5层 邮编: 315040 T HL (86-574)89070271 T TY (86-574)89070211 e [sgs.china@sgs.com](mailto:sgs.china@sgs.com)

# 测试报告 (SVHC)

No. NGBEC1602081004

日期: 2016年05月24日 第10页,共16页

附录

所有测试的SVHC:

| 批次   | 序号  | 物质名称  | CAS No.                               | RL (%) | 样品ID    |
|------|-----|---|---------------------------------------|--------|---------|
| VIII | 100 | 环己烷-1,2-二羧酸酐,顺式-环己烷-1,2-二羧酸酐,反式-环己烷-1,2-二羧酸酐      | 85-42-7,<br>13149-00-3,<br>14166-21-3 | 0.050  | 002     |
| VIII | 101 | 偶氮二甲酰胺  | 123-77-3                              | 0.050  | 002     |
| VIII | 102 | 二丁基二氯化锡(DBTC)                                     | 683-18-1                              | 0.050  | 002     |
| VIII | 103 | 硫酸二乙酯   | 64-67-5                               | 0.050  | 002     |
| VIII | 104 | 邻苯二甲酸二异戊酯   | 605-50-5                              | 0.050  | 002     |
| VIII | 105 | 硫酸二甲酯   | 77-78-1                               | 0.050  | 002     |
| VIII | 106 | 地乐酚   | 88-85-7                               | 0.050  | 002     |
| VIII | 107 | 双(十八烷基)二氧化三铅*                                     | 12578-12-0                            | 0.005  | 002     |
| VIII | 108 | C16-18-脂肪酸铅*                                      | 91031-62-8                            | 0.005  | 002     |
| VIII | 109 | 呋喃  | 110-00-9                              | 0.050  | 002     |
| VIII | 110 | 全氟十一烷酸  | 2058-94-8                             | 0.050  | 002     |
| VIII | 111 | 全氟十四烷酸  | 376-06-7                              | 0.050  | 002     |
| VIII | 112 | 甲基六氢邻苯二甲酸酐,4-甲基六氢邻苯二甲酸酐,1-甲基六氢邻苯二甲酸酐,3-甲基六氢邻苯二甲酸酐 | ☆                                     | 0.050  | 002     |
| VIII | 113 | 四氟硼酸铅*  | 13814-96-5                            | 0.005  | 002,003 |
| VIII | 114 | 氨基氰铅盐*  | 20837-86-9                            | 0.005  | 002,003 |
| VIII | 115 | 硝酸铅*  | 10099-74-8                            | 0.005  | 002,003 |
| VIII | 116 | 一氧化铅*   | 1317-36-8                             | 0.005  | 002,003 |
| VIII | 117 | 碱式硫酸铅*  | 12036-76-9                            | 0.005  | 002,003 |
| VIII | 118 | 四氧化三铅*  | 1314-41-6                             | 0.005  | 002,003 |



Unless otherwise agreed in writing, this document is issued by the Company subject to its General Conditions of Service printed overleaf, available on request or accessible at <http://www.sgs.com/en/Terms-and-Conditions.aspx> and, for electronic format documents, subject to Terms and Conditions for Electronic Documents at <http://www.sgs.com/en/Terms-and-Conditions/Terms-e-Documents.aspx>. Attention is drawn to the limitation of liability, indemnification and jurisdiction issues defined therein. Any holder of this document is advised that information contained hereon reflects the Company's findings at the time of its intervention only and within the limits of Client's instructions, if any. The Company's sole responsibility is to its Client and this document does not exonerate parties to a transaction from exercising all their rights and obligations under the transaction documents. This document cannot be reproduced except in full, without prior written approval of the Company. Any unauthorized alteration, forgery or falsification of the content or appearance of this document is unlawful and offenders may be prosecuted to the fullest extent of the law. Unless otherwise stated the results shown in this test report refer only to the sample(s) tested.

Attention: To check the authenticity of testing / inspection report & certificate, please contact us at telephone: (86-755) 8307 1443, or email: [CN.Doccheck@sgs.com](mailto:CN.Doccheck@sgs.com)

SGS-160208 Standards Technical Services Co., Ltd. 14/F West of Building 4, Lingyin Industry Park, No.1177 Lingyin Road, Ningbo National Hi-Tech Zone, Ningbo, Zhejiang, China 315040 T E&E (86-574)89070249 T ML (86-574)89070242 www.sgsgroup.com.cn  
 中国·浙江·宁波市国家高新区凌云路1177号凌云产业园4号楼西1-5层 邮编: 315040 T HL (86-574)89070271 T TY (86-574)89070211 e [sgs.china@sgs.com](mailto:sgs.china@sgs.com)

# 测试报告 (SVHC)

No. NGBEC1602081004

日期: 2016年05月24日 第11页,共16页

附录

所有测试的SVHC:

| 批次   | 序号  | 物质名称              | CAS No.     | RL (%) | 样品ID    |
|------|-----|-------------------|-------------|--------|---------|
| VIII | 119 | 钛酸铅*              | 12060-00-3  | 0.005  | 002,003 |
| VIII | 120 | 钛酸铅锆*             | 12626-81-2  | 0.005  | 002,003 |
| VIII | 121 | 甲氧基乙酸             | 625-45-6    | 0.050  | 002     |
| VIII | 122 | 1,2-环氧丙烷          | 75-56-9     | 0.050  | 002     |
| VIII | 123 | N,N-二甲基甲酰胺        | 68-12-2     | 0.050  | 002     |
| VIII | 124 | N-甲基乙酰胺           | 79-16-3     | 0.050  | 002     |
| VIII | 125 | 邻苯二甲酸正戊基异戊基酯      | 776297-69-9 | 0.050  | 002     |
| VIII | 126 | 邻-氨基偶氮甲苯          | 97-56-3     | 0.050  | 002     |
| VIII | 127 | 2-氨基甲苯            | 95-53-4     | 0.050  | 002     |
| VIII | 128 | 全氟十三烷酸            | 72629-94-8  | 0.050  | 002     |
| VIII | 129 | 硫酸四氧化五铅*          | 12065-90-6  | 0.005  | 002,003 |
| VIII | 130 | 铅锑黄*              | 8012-00-8   | 0.005  | 002,003 |
| VIII | 131 | 掺杂铅的硅酸钡*          | 68784-75-8  | 0.005  | 002,003 |
| VIII | 132 | 硅酸铅*              | 11120-22-2  | 0.005  | 002,003 |
| VIII | 133 | 二碱式亚硫酸铅*          | 62229-08-7  | 0.005  | 002,003 |
| VIII | 134 | 四乙基铅*             | 78-00-2     | 0.005  | 002     |
| VIII | 135 | 硫酸三氧化四铅*          | 12202-17-4  | 0.005  | 002,003 |
| VIII | 136 | 全氟十二烷酸            | 307-55-1    | 0.050  | 002     |
| VIII | 137 | 碱式碳酸铅*            | 1319-46-6   | 0.005  | 002,003 |
| VIII | 138 | 二碱式亚磷酸铅*          | 12141-20-7  | 0.005  | 002,003 |
| IX   | 139 | 4-壬基(支链与直链)苯酚乙氧基醚 | -           | 0.050  | 002     |



Unless otherwise agreed in writing, this document is issued by the Company subject to its General Conditions of Service printed overleaf, available on request or accessible at <http://www.sgs.com/en/Terms-and-Conditions.aspx> and, for electronic format documents, subject to Terms and Conditions for Electronic Documents at <http://www.sgs.com/en/Terms-and-Conditions/Terms-e-Documents.aspx>. Attention is drawn to the limitation of liability, indemnification and jurisdiction issues defined therein. Any holder of this document is advised that information contained hereon reflects the Company's findings at the time of its intervention only and within the limits of Client's instructions, if any. The Company's sole responsibility is to its Client and this document does not exonerate parties to a transaction from exercising all their rights and obligations under the transaction documents. This document cannot be reproduced except in full, without prior written approval of the Company. Any unauthorized alteration, forgery or falsification of the content or appearance of this document is unlawful and offenders may be prosecuted to the fullest extent of the law. Unless otherwise stated the results shown in this test report refer only to the sample(s) tested.

Attention: To check the authenticity of testing / inspection report & certificate, please contact us at telephone: (86-755) 8307 1443, or email: [CN.Doccheck@sgs.com](mailto:CN.Doccheck@sgs.com)

SGS-1620 Standards Technical Services Co., Ltd. 14/F West of Building 4, Lingyin Industry Park, No.1177 Lingyin Road, Ningbo National Hi-Tech Zone, Ningbo, Zhejiang, China 315040 T E&E (86-574)89070249 T ML (86-574)89070242 www.sgsgroup.com.cn  
 中国·浙江·宁波市国家高新区凌云路1177号凌云产业园4号楼西1-5层 邮编: 315040 T HL (86-574)89070271 T TY (86-574)89070211 e [sgs.china@sgs.com](mailto:sgs.china@sgs.com)

# 测试报告 (SVHC)

No. NGBEC1602081004

日期: 2016年05月24日 第12页,共16页

附录

所有测试的SVHC:

| 批次  | 序号  | 物质名称                               | CAS No.    | RL (%) | 样品ID    |
|-----|-----|------------------------------------|------------|--------|---------|
| IX  | 140 | 全氟辛酸铵(APFO)                        | 3825-26-1  | 0.050  | 002     |
| IX  | 141 | 氧化镉*                               | 1306-19-0  | 0.005  | 002,003 |
| IX  | 142 | 镉*                                 | 7440-43-9  | 0.005  | 002,003 |
| IX  | 143 | 邻苯二甲酸二正戊酯(DPP)                     | 131-18-0   | 0.050  | 002     |
| IX  | 144 | 全氟辛酸(PFOA)                         | 335-67-1   | 0.050  | 002     |
| X   | 145 | 硫化镉*                               | 1306-23-6  | 0.005  | 002,003 |
| X   | 146 | 邻苯二甲酸二正己酯                          | 84-75-3    | 0.050  | 002     |
| X   | 147 | C.I.直接红28                          | 573-58-0   | 0.050  | 002     |
| X   | 148 | C.I.直接黑38                          | 1937-37-7  | 0.050  | 002     |
| X   | 149 | 2-巯基咪唑啉                            | 96-45-7    | 0.050  | 002     |
| X   | 150 | 乙酸铅*                               | 301-04-2   | 0.005  | 002     |
| X   | 151 | 磷酸三二甲苯酯                            | 25155-23-1 | 0.050  | 002     |
| XI  | 152 | 邻苯二甲酸二(支链与直链)己基酯                   | 68515-50-4 | 0.050  | 002     |
| XI  | 153 | 氯化镉*                               | 10108-64-2 | 0.005  | 002,003 |
| XI  | 154 | 水合过硼酸钠*                            | -          | 0.005  | 002,003 |
| XI  | 155 | 过硼酸钠*                              | 7632-04-4  | 0.005  | 002,003 |
| XII | 156 | 2-(2H-苯并三唑-2-基)-4,6-二叔戊基苯酚(UV-328) | 25973-55-1 | 0.050  | 002     |
| XII | 157 | 2-苯并三唑-2-基-4,6-二叔丁基苯酚(UV-320)      | 3846-71-7  | 0.050  | 002     |
| XII | 158 | 二正辛基-双(2-乙基己基巯基乙酸酯)锡(DOTE)         | 15571-58-1 | 0.050  | 002     |
| XII | 159 | 氟化镉*                               | 7790-79-6  | 0.005  | 002,003 |



Unless otherwise agreed in writing, this document is issued by the Company subject to its General Conditions of Service printed overleaf, available on request or accessible at <http://www.sgs.com/en/Terms-and-Conditions.aspx> and, for electronic format documents, subject to Terms and Conditions for Electronic Documents at <http://www.sgs.com/en/Terms-and-Conditions/Terms-e-Documents.aspx>. Attention is drawn to the limitation of liability, indemnification and jurisdiction issues defined therein. Any holder of this document is advised that information contained hereon reflects the Company's findings at the time of its intervention only and within the limits of Client's instructions, if any. The Company's sole responsibility is to its Client and this document does not exonerate parties to a transaction from exercising all their rights and obligations under the transaction documents. This document cannot be reproduced except in full, without prior written approval of the Company. Any unauthorized alteration, forgery or falsification of the content or appearance of this document is unlawful and offenders may be prosecuted to the fullest extent of the law. Unless otherwise stated the results shown in this test report refer only to the sample(s) tested.

Attention: To check the authenticity of testing /inspection report & certificate, please contact us at telephone: (86-755) 8307 1443, or email: [CN.Doccheck@sgs.com](mailto:CN.Doccheck@sgs.com)

SGS-20 Standards Technical Services Co., Ltd  
Ningbo Branch

14/F West of Building 4, Lingyin Industry Park, No.1177 Lingyin Road, Ningbo National Hi-Tech Zone, Ningbo, Zhejiang, China 315040  
中国·浙江·宁波市国家高新区凌云路1177号凌云产业园4号楼西1-5层

1 E&E (86-574)89070249 1 ML (86-574)89070242 www.sgsgroup.com.cn  
1 HL (86-574)89070271 1 TY (86-574)89070211 e sgs.china@sgs.com

测试报告  
(SVHC)

No. NGBEC1602081004

日期: 2016年05月24日 第13页,共16页

附录

所有测试的SVHC:

| 批次   | 序号  | 物质名称  | CAS No.                           | RL (%) | 样品ID    |
|------|-----|---|-----------------------------------|--------|---------|
| XII  | 160 | 硫酸镉*  | 10124-36-4,311<br>19-53-6         | 0.005  | 002,003 |
| XII  | 161 | 二正辛基-双(2-乙基己基巯基乙酸酯)锡(DOTE)和单辛基-三(2-乙基己基巯基乙酸酯)锡(MOTE)的反应物  | -                                 | 0.050  | 002     |
| XIII | 162 | 1,2-苯二甲酸, 二(C6-10)烷基酯 / 1,2-苯二甲酸, 混合二己二辛二癸酯, 其中邻苯二甲酸二己酯含量≥0.3%  | 68515-51-5,686<br>48-93-1         | 0.050  | 002     |
| XIII | 163 | 5-二级丁基-2-(2,4-二甲基环己-3-烯-1-基)-5-甲基-1,3-二恶烷[1], 5-二级丁基-2-(4,6-二甲基环己-3-烯-1-基)-5-甲基-1,3-二恶烷[2] [任何[1]和[2]或者其任意组合的单独异构体或其任何组合] |                                   | 0.050  | 002     |
| XIV  | 164 | 1,3-丙磺酸内酯   | 1120-71-4                         | 0.050  | 002     |
| XIV  | 165 | 2,4-二叔丁基-6-(5-氯苯并三唑-2-基)苯酚(UV-327)  | 3864-99-1                         | 0.050  | 002     |
| XIV  | 166 | 2-(2H-苯并三唑-2-基)-4-叔丁基-6-仲丁基苯酚(UV-350)   | 36437-37-3                        | 0.050  | 002     |
| XIV  | 167 | 硝基苯   | 98-95-3                           | 0.050  | 002     |
| XIV  | 168 | 全氟壬酸及其钠盐和铵盐   | 375-95-1,21049<br>-39-8,4149-60-4 | 0.050  | 002     |



Unless otherwise agreed in writing, this document is issued by the Company subject to its General Conditions of Service printed overleaf, available on request or accessible at <http://www.sgs.com/en/Terms-and-Conditions.aspx> and, for electronic format documents, subject to Terms and Conditions for Electronic Documents at <http://www.sgs.com/en/Terms-and-Conditions/Terms-e-Documents.aspx>. Attention is drawn to the limitation of liability, indemnification and jurisdiction issues defined therein. Any holder of this document is advised that information contained hereon reflects the Company's findings at the time of its intervention only and within the limits of Client's instructions, if any. The Company's sole responsibility is to its Client and this document does not exonerate parties to a transaction from exercising all their rights and obligations under the transaction documents. This document cannot be reproduced except in full, without prior written approval of the Company. Any unauthorized alteration, forgery or falsification of the content or appearance of this document is unlawful and offenders may be prosecuted to the fullest extent of the law. Unless otherwise stated the results shown in this test report refer only to the sample(s) tested.

Attention: To check the authenticity of testing / inspection report & certificate, please contact us at telephone: (86-755) 8307 1443, or email: [CN.Doccheck@sgs.com](mailto:CN.Doccheck@sgs.com)

SGS Standards Technical Services Co., Ltd  
Ningbo Branch

14/F West of Building 4, Lingyin Industry Park, No.1177 Lingyin Road, Ningbo National Hi-Tech Zone, Ningbo, Zhejiang, China 315040  
中国·浙江·宁波市国家高新区凌云路1177号凌云产业园4号楼西1-5层

T E&E (86-574)89070249 T ML (86-574)89070242 www.sgs.com.cn  
T HL (86-574)89070271 T TY (86-574)89070211 e sgs.china@sgs.com

# 测试报告 (SVHC)

No. NGBEC1602081004

日期: 2016年05月24日 第14页,共16页

附件:

1.0 1.25 DF14 GH ZH PH PA PHSD DF11 C1251 51146 FI-S  
 PHD YHD200 SMW SMH200 SMH200-H 20039WR 杜邦  
 2.0 XH/TJC3 XA HA XHB EH SZN SAN SCN SCND JC15 JC20  
 JC25 5264 250 LGC CH2.5 EI/小EP S11 HR 线扣 YH025 35155  
 5102 5240 SMH250 SMP250 SMW250 25048HS 25045HP  
 SM TJC8/杜邦2.54 TJC8A/杜邦带锁 TJC8B TJC8H 5051/2510 543  
 美尚美 CH10 25415 43645 43020 43025 5500  
 5600 VH VHRR/YH396 VHR 35156 2139/3.96 90331 5195 5196  
 39612 FL 5557 5559 5566 5569 42474 42475 SL RV42 CL014/OTP  
 EL YL 小型EL QH NV 50300 50301 8981/大四P 5058/5.08 5197  
 5198 5025 L6.2 VL VLP/VLR 3191 5199 TJC2 TJC2A TJC2B STV5  
 YHL500 YWL500 TJC4 TJC1 SMF Cy-X201/35108 35150 35151 35224  
 35180 35965 1806 110 2.8 42021 42022 42002 6.3 250 35955 SA  
 SCS 35189 35196 DF11 MX3.0  
 1.58 51005 51006 BH3.5 BH4.0 EL 63080 187 250 51004 TJC15  
 DF13 D4081 D4082 D6301 D6302 F1001-T11 SIN-T11 774-2P 774-3P  
 774-5P 2060-401 2060-402 2060-403 773-102 773-104 773-106 773-108  
 778 294 TU-JTK型叉型预绝缘端头 (SV) TU叉型裸端头 (SNB)  
 TO-JTK型圆形预绝缘端头 (RV) 公预绝缘接头 (MDD) 母预绝缘接头 (FDD)  
 TG-JT管型预绝缘端头 电缆防水接头 接线端子 软护套 IDC CONNECTOR AUTO  
 CONNECTOR DJ7021-1.5-11 DJ7021-1.5-21 DT04  
 DT06 UY/K1 UY2/K2 UR/K3 UR2 UB/K4 UB2A UG/K5 U1R/K8 U1B K9  
 HJKT10 UDW2 314



Unless otherwise agreed in writing, this document is issued by the Company subject to its General Conditions of Service printed overleaf, available on request or accessible at <http://www.sgs.com/en/Terms-and-Conditions.aspx> and, for electronic format documents, subject to Terms and Conditions for Electronic Documents at <http://www.sgs.com/en/Terms-and-Conditions/Terms-e-Documents.aspx>. Attention is drawn to the limitation of liability, indemnification and jurisdiction issues defined therein. Any holder of this document is advised that information contained hereon reflects the Company's findings at the time of its intervention only and within the limits of Client's instructions, if any. The Company's sole responsibility is to its Client and this document does not exonerate parties to a transaction from exercising all their rights and obligations under the transaction documents. This document cannot be reproduced except in full, without prior written approval of the Company. Any unauthorized alteration, forgery or falsification of the content or appearance of this document is unlawful and offenders may be prosecuted to the fullest extent of the law. Unless otherwise stated the results shown in this test report refer only to the sample(s) tested.

Attention: To check the authenticity of testing /inspection report & certificate, please contact us at telephone: (86-755) 8307 1443, or email: [CN.Doccheck@sgs.com](mailto:CN.Doccheck@sgs.com)

SGS (China) Standards Technical Services Co., Ltd. Ningbo Branch 14/F West of Building 4, Lingyin Industry Park, No.1177 Lingyin Road, Ningbo National Hi-Tech Zone, Ningbo, Zhejiang, China 315040 1 E&E (86-574)89070249 1 ML (86-574)89070242 www.sgsgroup.com.cn  
 中国·浙江·宁波市国家高新区凌云路1177号凌云产业园4号楼西1-5层 邮编: 315040 1 HL (86-574)89070271 1 TY (86-574)89070211 e sgs.china@sgs.com



## SVHC 测试流程图

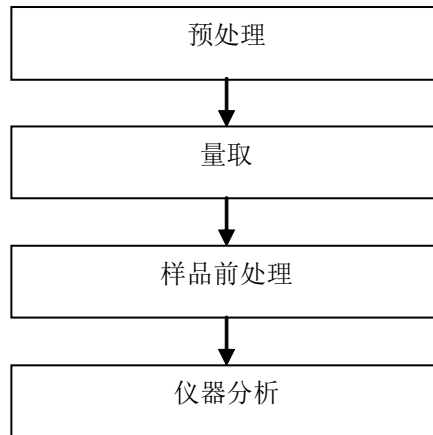

Unless otherwise agreed in writing, this document is issued by the Company subject to its General Conditions of Service printed overleaf, available on request or accessible at <http://www.sgs.com/en/Terms-and-Conditions.aspx> and, for electronic format documents, subject to Terms and Conditions for Electronic Documents at <http://www.sgs.com/en/Terms-and-Conditions/Terms-e-Documents.aspx>. Attention is drawn to the limitation of liability, indemnification and jurisdiction issues defined therein. Any holder of this document is advised that information contained hereon reflects the Company's findings at the time of its intervention only and within the limits of Client's instructions, if any. The Company's sole responsibility is to its Client and this document does not exonerate parties to a transaction from exercising all their rights and obligations under the transaction documents. This document cannot be reproduced except in full, without prior written approval of the Company. Any unauthorized alteration, forgery or falsification of the content or appearance of this document is unlawful and offenders may be prosecuted to the fullest extent of the law. Unless otherwise stated the results shown in this test report refer only to the sample(s) tested.

Attention: To check the authenticity of testing / inspection report & certificate, please contact us at telephone: (86-755) 8307 1443, or email: [CN.Doccheck@sgs.com](mailto:CN.Doccheck@sgs.com)

## 测试报告 (SVHC)

No. NGBEC1602081004

日期: 2016年05月24日 第16页,共16页

样品照片:

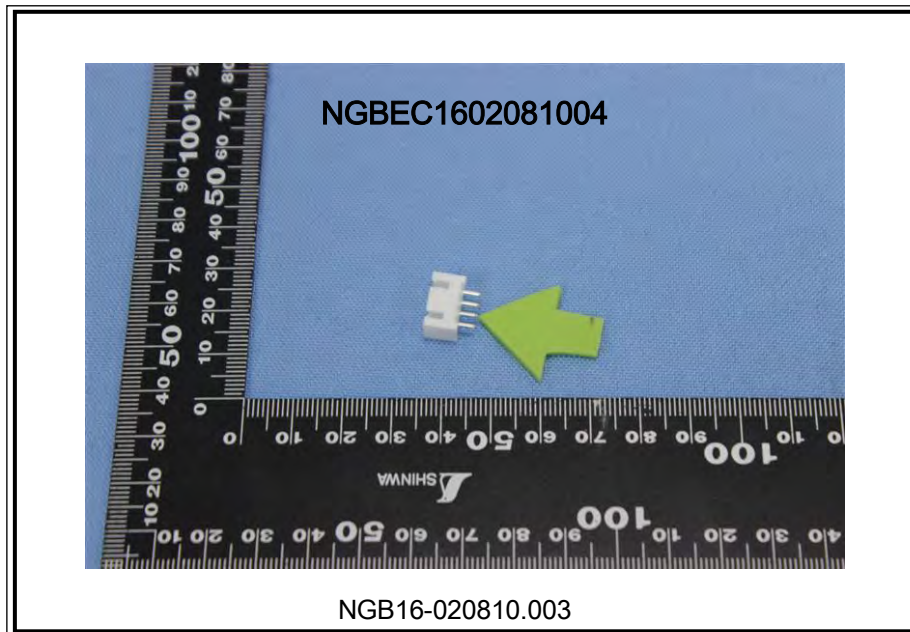
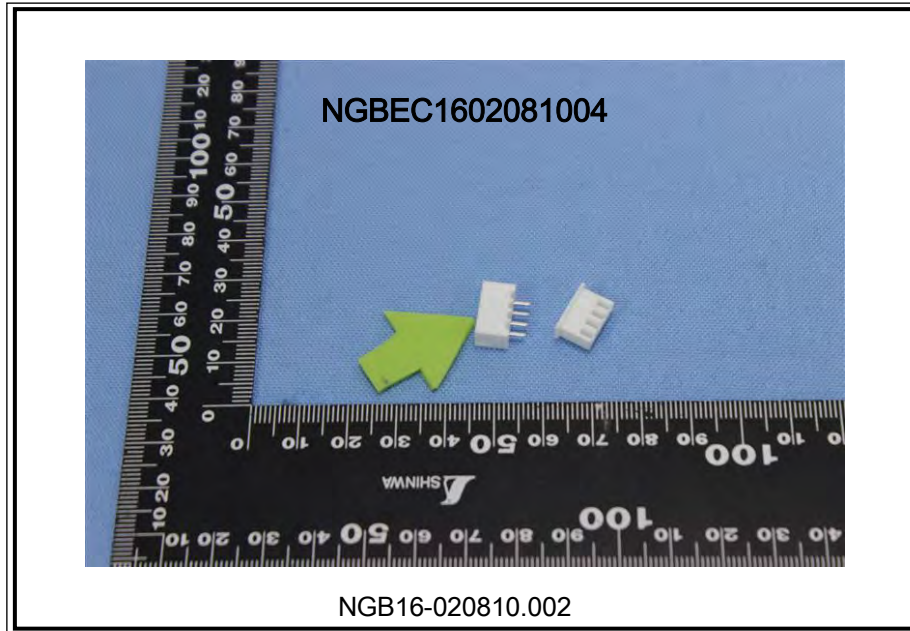

此照片仅限于随SGS正本报告使用

\*\*\* 报告完 \*\*\*



Unless otherwise agreed in writing, this document is issued by the Company subject to its General Conditions of Service printed overleaf, available on request or accessible at <http://www.sgs.com/en/Terms-and-Conditions.aspx> and, for electronic format documents, subject to Terms and Conditions for Electronic Documents at <http://www.sgs.com/en/Terms-and-Conditions/Terms-e-Documents.aspx>. Attention is drawn to the limitation of liability, indemnification and jurisdiction issues defined therein. Any holder of this document is advised that information contained hereon reflects the Company's findings at the time of its intervention only and within the limits of Client's instructions, if any. The Company's sole responsibility is to its Client and this document does not exonerate parties to a transaction from exercising all their rights and obligations under the transaction documents. This document cannot be reproduced except in full, without prior written approval of the Company. Any unauthorized alteration, forgery or falsification of the content or appearance of this document is unlawful and offenders may be prosecuted to the fullest extent of the law. Unless otherwise stated the results shown in this test report refer only to the sample(s) tested.

Attention: To check the authenticity of testing /inspection report & certificate, please contact us at telephone: (86-755) 8307 1443, or email: [CN.Doccheck@sgs.com](mailto:CN.Doccheck@sgs.com)

SGS-160208 Standards Technical Services Co., Ltd  
Ningbo Branch

14/F West of Building 4, Lingyin Industry Park, No.1177 Lingyin Road, Ningbo National Hi-Tech Zone, Ningbo, Zhejiang, China 315040  
中国·浙江·宁波市国家高新区凌云路1177号凌云产业园4号楼西1-5层

1 E&E (86-574)89070249 1 ML (86-574)89070242 www.sgs.com.cn  
1 HL (86-574)89070271 1 TY (86-574)89070211 e sgs.china@sgs.com

# 测试报告

No. NGBEC1602080906

日期: 2016年05月25日 第1页,共12页

以下测试之样品是由申请者所提供及确认: 连接器

SGS工作编号: NP16-001905 - NB  
 主要成分: 尼龙66  
 锡 铜  
 料号: A2501  
 型号: XH  
 客户参考信息: 见附件  
 样品接收日期: 2016年05月16日  
 测试周期: 2016年05月16日 - 2016年05月20日  
 测试要求: 根据客户要求测试  
 测试方法: 请参见下一页  
 测试结果: 请参见下一页

测试结果概要:

| 测试要求                     | 结论    |
|--------------------------|-------|
| 卤素                       | 见测试结果 |
| 多环芳香烃(PAHs)              | 符合    |
| 邻苯二甲酸盐(或酯)               | 见测试结果 |
| 全氟辛烷磺酸 (PFOS)和全氟辛酸(PFOA) | 见测试结果 |

通标标准技术服务有限公司宁波分公司  
 授权签名

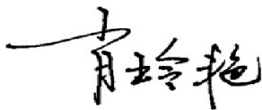

Iris Xiao 肖玲艳  
 批准签署人

本报告是编号为NGBEC1602080905 报告的中文版本



Unless otherwise agreed in writing, this document is issued by the Company subject to its General Conditions of Service printed overleaf, available on request or accessible at <http://www.sgs.com/en/Terms-and-Conditions.aspx> and, for electronic format documents, subject to Terms and Conditions for Electronic Documents at <http://www.sgs.com/en/Terms-and-Conditions/Terms-e-Documents.aspx>. Attention is drawn to the limitation of liability, indemnification and jurisdiction issues defined therein. Any holder of this document is advised that information contained hereon reflects the Company's findings at the time of its intervention only and within the limits of Client's instructions, if any. The Company's sole responsibility is to its Client and this document does not exonerate parties to a transaction from exercising all their rights and obligations under the transaction documents. This document cannot be reproduced except in full, without prior written approval of the Company. Any unauthorized alteration, forgery or falsification of the content or appearance of this document is unlawful and offenders may be prosecuted to the fullest extent of the law. Unless otherwise stated the results shown in this test report refer only to the sample(s) tested.

Attention: To check the authenticity of testing /inspection report & certificate, please contact us at telephone: (86-755) 8307 1443, or email: [CN.Doccheck@sgs.com](mailto:CN.Doccheck@sgs.com)

14/F West of Building 4, Lingyin Industry Park, No.1177 Lingyin Road, Ningbo National Hi-Tech Zone, Ningbo, Zhejiang, China 315040 T E&E (86-574)89070249 T ML (86-574)89070242 www.sgsgroup.com.cn  
 中国·浙江·宁波市国家高新区凌云路1177号凌云产业园4号楼西1-5层 邮编: 315040 T HL (86-574)89070271 T TY (86-574)89070211 e [sgs.china@sgs.com](mailto:sgs.china@sgs.com)

# 测试报告

No. NGBEC1602080906

日期: 2016年05月25日 第2页,共12页

测试结果:

## 测试样品描述:

| 样品编号 | SGS样品ID          | 描述   |
|------|------------------|------|
| SN1  | NGB16-020809.002 | 白色塑料 |

备注:

- (1) 1 mg/kg = 0.0001%
- (2) MDL = 方法检测限
- (3) ND = 未检出 (< MDL)
- (4) "-" = 未规定

## 卤素

测试方法: 参照EN 14582:2007方法测定, 采用IC进行分析.

| 测试项目  | 单位    | MDL | 002 |
|-------|-------|-----|-----|
| 氟(F)  | mg/kg | 50  | ND  |
| 氯(Cl) | mg/kg | 50  | ND  |
| 溴(Br) | mg/kg | 50  | ND  |
| 碘(I)  | mg/kg | 50  | ND  |

## 多环芳香烃(PAHs)

测试方法: 参考AfPS GS 2014:01 PAK方法测试, 采用GC-MS进行分析.

| 测试项目          | 单位    | MDL | 002 |
|---------------|-------|-----|-----|
| 萘(ANY)        | mg/kg | 0.1 | ND  |
| 芘(萘嵌戊烷) (ANA) | mg/kg | 0.1 | ND  |
| 芴 (FLU)       | mg/kg | 0.1 | ND  |
| 菲 (PHE)       | mg/kg | 0.1 | ND  |
| 蒽 (ANT)       | mg/kg | 0.1 | ND  |
| 荧蒽 (FLT)      | mg/kg | 0.1 | ND  |
| 芘 (PYR)       | mg/kg | 0.1 | ND  |
| 苯并(a)芘 (BaP)  | mg/kg | 0.1 | ND  |
| 苯并(e)芘 (BeP)  | mg/kg | 0.1 | ND  |
| 苯并(a)蒽 (BaA)  | mg/kg | 0.1 | ND  |
| 苯并(b)荧蒽 (BbF) | mg/kg | 0.1 | ND  |
| 苯并(j)荧蒽 (BjF) | mg/kg | 0.1 | ND  |
| 苯并(k)荧蒽 (BkF) | mg/kg | 0.1 | ND  |



Unless otherwise agreed in writing, this document is issued by the Company subject to its General Conditions of Service printed overleaf, available on request or accessible at <http://www.sgs.com/en/Terms-and-Conditions.aspx> and, for electronic format documents, subject to Terms and Conditions for Electronic Documents at <http://www.sgs.com/en/Terms-and-Conditions/Terms-e-Documents.aspx>. Attention is drawn to the limitation of liability, indemnification and jurisdiction issues defined therein. Any holder of this document is advised that information contained hereon reflects the Company's findings at the time of its intervention only and within the limits of Client's instructions, if any. The Company's sole responsibility is to its Client and this document does not exonerate parties to a transaction from exercising all their rights and obligations under the transaction documents. This document cannot be reproduced except in full, without prior written approval of the Company. Any unauthorized alteration, forgery or falsification of the content or appearance of this document is unlawful and offenders may be prosecuted to the fullest extent of the law. Unless otherwise stated the results shown in this test report refer only to the sample(s) tested.

Attention: To check the authenticity of testing / inspection report & certificate, please contact us at telephone: (86-755) 8307 1443, or email: [CN.Doccheck@sgs.com](mailto:CN.Doccheck@sgs.com)

14/F West of Building 4, Lingyin Industry Park, No.1177 Lingyin Road, Ningbo National Hi-Tech Zone, Ningbo, Zhejiang, China 315040 T E&E (86-574)89070249 T ML (86-574)89070242 www.sgs.com.cn  
 中国·浙江·宁波市国家高新区凌云路1177号凌云产业园4号楼西1-5层 邮编: 315040 T HL (86-574)89070271 T TY (86-574)89070211 e [sgs.china@sgs.com](mailto:sgs.china@sgs.com)

## 测试报告

No. NGBEC1602080906

日期: 2016年05月25日 第3页,共12页

| 测试项目  | 单位    | MDL | 002       |
|---|-------|-----|-----------|
| 苯并(k)荧蒽 (BkF)   | mg/kg | 0.1 | ND        |
| 屈 (CHR)   | mg/kg | 0.1 | ND        |
| 二苯并(a,h)蒽(DBA)  | mg/kg | 0.1 | ND        |
| 苯并(g,h,i)芘(二苯嵌苯) (BPE)  | mg/kg | 0.1 | ND        |
| 茚并(1,2,3-c,d)芘 (IPY)  | mg/kg | 0.1 | ND        |
| 7项多环芳香烃总和[苊烯(ANY),苊(萘嵌戊烷) (ANA),芴 (FLU),菲 (PHE),芘 (PYR),蒽 (ANT),荧蒽 (FLT)] | mg/kg | -   | ND        |
| 萘 (NAP)   | mg/kg | 0.1 | 0.2       |
| 18项多环芳香烃总和  | mg/kg | -   | 0.2       |
| 材料分类  | -     | -   | 2         |
| <b>结论</b>   |       |     | <b>符合</b> |

### 备注:

- (1) 材料分类由客户提供, 未经SGS评估。
- (2) 根据客户提供的信息, 测试样品为产品安全法涉及的非玩具产品。



Unless otherwise agreed in writing, this document is issued by the Company subject to its General Conditions of Service printed overleaf, available on request or accessible at <http://www.sgs.com/en/Terms-and-Conditions.aspx> and, for electronic format documents, subject to Terms and Conditions for Electronic Documents at <http://www.sgs.com/en/Terms-and-Conditions/Terms-e-Documents.aspx>. Attention is drawn to the limitation of liability, indemnification and jurisdiction issues defined therein. Any holder of this document is advised that information contained hereon reflects the Company's findings at the time of its intervention only and within the limits of Client's instructions, if any. The Company's sole responsibility is to its Client and this document does not exonerate parties to a transaction from exercising all their rights and obligations under the transaction documents. This document cannot be reproduced except in full, without prior written approval of the Company. Any unauthorized alteration, forgery or falsification of the content or appearance of this document is unlawful and offenders may be prosecuted to the fullest extent of the law. Unless otherwise stated the results shown in this test report refer only to the sample(s) tested.

Attention: To check the authenticity of testing / inspection report & certificate, please contact us at telephone: (86-755) 8307 1443, or email: [CN.Doccheck@sgs.com](mailto:CN.Doccheck@sgs.com)

SGS Standards Technical Services Co., Ltd  
Ningbo Branch

1-6F West of Building 4, Lingyin Industry Park, No.1177 Lingyin Road, Ningbo National Hi-Tech Zone, Ningbo, Zhejiang, China 315040  
中国·浙江·宁波市国家高新区凌云路1177号凌云产业园4号楼西1-5层

T E&E (86-574)89070249 T ML (86-574)89070242 www.sgs.com.cn  
T HL (86-574)89070271 T TY (86-574)89070211 e sgs.china@sgs.com

**AIPS(德国产品安全委员会):GS认证对多环芳香烃的要求**

| 参数   | 1类                                   | 2类  |              | 3类                                       |              |
|--|--------------------------------------|---|--------------|--|--------------|
|  | 设计意图为放入口中的材料或者玩具上与皮肤接触的材料(接触时间大于30秒) | 未在1类规定中涵盖的材料,且可能与皮肤接触时间大于30秒的材料(长时间接触皮肤)或频繁接触皮肤 |              | 未在1和2类规定中涵盖的材料,且可能与皮肤接触的少于30秒的材料(短期接触皮肤) |              |
|  |                                      | 2009/48/EC中适用的玩具                                | 产品安全法涉及的其他产品 | 2009/48/EC中适用的玩具                         | 产品安全法涉及的其他产品 |
| 苯并(a)芘 (BaP) mg/kg   | <0.2                                 | <0.2  | <0.5         | <0.5                                     | <1           |
| 苯并(e)芘 (BeP) mg/kg   | <0.2                                 | <0.2  | <0.5         | <0.5                                     | <1           |
| 苯并(a)蒽 (BaA) mg/kg   | <0.2                                 | <0.2  | <0.5         | <0.5                                     | <1           |
| 苯并(b)荧蒽 (BbF) mg/kg  | <0.2                                 | <0.2  | <0.5         | <0.5                                     | <1           |
| 苯并(j)荧蒽 (BjF) mg/kg  | <0.2                                 | <0.2  | <0.5         | <0.5                                     | <1           |
| 苯并(k)荧蒽 mg/kg  | <0.2                                 | <0.2  | <0.5         | <0.5                                     | <1           |
| 屈 (CHR) mg/kg  | <0.2                                 | <0.2  | <0.5         | <0.5                                     | <1           |
| 二苯并(a,h)蒽 (DBA)mg/kg   | <0.2                                 | <0.2  | <0.5         | <0.5                                     | <1           |
| 苯并(g,h,i)花(二苯嵌苯) (BPE)n mg/kg  | <0.2                                 | <0.2  | <0.5         | <0.5                                     | <1           |
| 茚苯(1,2,3-c,d)芘 (IPY) mg/kg   | <0.2                                 | <0.2  | <0.5         | <0.5                                     | <1           |
| 萘烯(ANY), 萘(蒽嵌戊烷) (ANA), 芴 (FLU), 菲 (PHE), 芘 (PYR), 蒽 (ANT), 荧蒽 (FLT)之和 mg/kg | <1 (总和)                              | <5 (总和)   | <10 (总和)     | <20 (总和)                                 | <50 (总和)     |
| 萘 (NAP) mg/kg  | <1                                   | <2  |              | <10                                      |              |
| 18 PAH之和   | <1                                   | <5  | <10          | <20                                      | <50          |

**邻苯二甲酸盐(或酯)**

测试方法: 参照EN 14372: 2004的方法测定, 采用GC-MS进行分析.



Unless otherwise agreed in writing, this document is issued by the Company subject to its General Conditions of Service printed overleaf, available on request or accessible at <http://www.sgs.com/en/Terms-and-Conditions.aspx> and, for electronic format documents, subject to Terms and Conditions for Electronic Documents at <http://www.sgs.com/en/Terms-and-Conditions/Terms-e-Documents.aspx>. Attention is drawn to the limitation of liability, indemnification and jurisdiction issues defined therein. Any holder of this document is advised that information contained hereon reflects the Company's findings at the time of its intervention only and within the limits of Client's instructions, if any. The Company's sole responsibility is to its Client and this document does not exonerate parties to a transaction from exercising all their rights and obligations under the transaction documents. This document cannot be reproduced except in full, without prior written approval of the Company. Any unauthorized alteration, forgery or falsification of the content or appearance of this document is unlawful and offenders may be prosecuted to the fullest extent of the law. Unless otherwise stated the results shown in this test report refer only to the sample(s) tested.

Attention: To check the authenticity of testing /inspection report & certificate, please contact us at telephone: (86-755) 8307 1443, or email: CN.Doccheck@sgs.com

SGS-16020 Standards Technical Services Co., Ltd  
Ningbo Branch

14/F West of Building 4, Lingyin Industry Park, No.1177 Lingyin Road, Ningbo National Hi-Tech Zone, Ningbo, Zhejiang, China 315040 1 E&E (86-574)89070249 1 ML (86-574)89070242 www.sgsgroup.com.cn  
中国·浙江·宁波市国家高新区凌云路1177号凌云产业园4号楼西1-5层 邮编: 315040 1 HL (86-574)89070271 1 TY (86-574)89070211 e sgs.china@sgs.com

# 测试报告

No. NGBEC1602080906

日期: 2016年05月25日 第5页,共12页

| 测试项目                          | CAS NO.                   | 单位 | MDL   | 002 |
|-------------------------------|---------------------------|----|-------|-----|
| 邻苯二甲酸二丁酯(DBP)                 | 84-74-2                   | %  | 0.003 | ND* |
| 邻苯二甲酸丁苄酯 (BBP)                | 85-68-7                   | %  | 0.003 | ND* |
| 邻苯二甲酸二(2-乙基己基)酯 (DEHP)        | 117-81-7                  | %  | 0.003 | ND* |
| 邻苯二甲酸二异壬酯 (DINP)              | 28553-12-0/<br>68515-48-0 | %  | 0.01  | ND  |
| 邻苯二甲酸二正辛酯 (DNOP)              | 117-84-0                  | %  | 0.003 | ND  |
| 邻苯二甲酸二异癸酯 (DIDP)              | 26761-40-0/<br>68515-49-1 | %  | 0.01  | ND  |
| 邻苯二甲酸二甲酯 (DMP)                | 131-11-3                  | %  | 0.003 | ND  |
| 邻苯二甲酸二乙酯 (DEP)                | 84-66-2                   | %  | 0.003 | ND  |
| 邻苯二甲酸二异丁酯(DIBP)               | 84-69-5                   | %  | 0.003 | ND* |
| 邻苯二甲酸二壬酯 (DNP)                | 84-76-4                   | %  | 0.003 | ND  |
| 邻苯二甲酸二异辛酯 (DiOP)              | 27554-26-3                | %  | 0.01  | ND  |
| 邻苯二甲酸二丙酯 (DPrP)               | 131-16-8                  | %  | 0.003 | ND  |
| 邻苯二甲酸二环己酯 (DCHP)              | 84-61-7                   | %  | 0.003 | ND  |
| 邻苯二甲酸二戊酯(DnPP)                | 131-18-0                  | %  | 0.003 | ND  |
| 邻苯二甲酸二苄酯(DBzP)                | 523-31-9                  | %  | 0.003 | ND  |
| 邻苯二甲酸二苯酯 (DPhP)               | 84-62-8                   | %  | 0.003 | ND  |
| 邻苯二甲酸-二(C7,C9,C11)烷基酯 (DHNUP) | 68515-42-4                | %  | 0.01  | ND  |
| 邻苯二甲酸二庚酯(DHpP)                | 3648-21-3                 | %  | 0.003 | ND  |
| 邻苯二甲酸二正己酯(DnHP)               | 84-75-3                   | %  | 0.003 | ND  |
| 邻苯二甲酸双十一酯                     | 3648-20-2                 | %  | 0.003 | ND  |
| 邻苯二甲酸二(2-丁氧基)乙酯 (DBEP)        | 117-83-9                  | %  | 0.003 | ND  |
| 邻苯二甲酸二(4-甲基-2-戊基)酯 (BMPP)     | 146-50-9                  | %  | 0.003 | ND  |
| 邻苯二甲酸二(2-乙氧基)乙酯 (DEEP)        | 605-54-9                  | %  | 0.003 | ND  |
| 邻苯二甲酸二(支链与直链)己基酯(DHP)         | 68515-50-4                | %  | 0.010 | ND  |
| 邻苯二甲酸二(2-甲氧基乙基)酯(DMEP)        | 117-82-8                  | %  | 0.003 | ND  |
| 邻苯二甲酸二丙烯酯 (DAP)               | 131-17-9                  | %  | 0.003 | ND  |
| 邻苯二甲酸癸基辛基酯(nDnOP)             | 119-07-3                  | %  | 0.003 | ND  |
| 邻苯二甲酸二癸酯(DnDP)                | 84-77-5                   | %  | 0.003 | ND  |
| 邻苯二甲酸二异戊酯(DiPP)               | 605-50-5                  | %  | 0.003 | ND  |
| 邻苯二甲酸异戊基戊酯((iPnPP)            | 776297-69-9               | %  | 0.003 | ND  |
| 邻苯二甲酸二C6-C8支链烷基酯(DIHP)        | 71888-89-6                | %  | 0.01  | ND  |
| 邻苯二甲酸二(支链与直链)戊基酯              | 84777-06-0                | %  | 0.003 | ND  |

备注:

- (1) DBP, BBP, DEHP 参考信息: 1907/2006/EC Reach 附录XVII的修正指令——552/2009/EC 第51条 (前身为2005/84/EC) 的要求:
- i) 不允许DBP, BBP, DEHP 质量浓度高于0.1%的可塑性物料用于玩具和儿童护理品.
  - ii) 当玩具和儿童护理品中的可塑性物料含DBP, BBP, DEHP 质量浓度高于0.1%时,不得投放市场. 详细信息请参见Regulation (EC) No 552/2009



Unless otherwise agreed in writing, this document is issued by the Company subject to its General Conditions of Service printed overleaf, available on request or accessible at <http://www.sgs.com/en/Terms-and-Conditions.aspx> and, for electronic format documents, subject to Terms and Conditions for Electronic Documents at <http://www.sgs.com/en/Terms-and-Conditions/Terms-e-Documents.aspx>. Attention is drawn to the limitation of liability, indemnification and jurisdiction issues defined therein. Any holder of this document is advised that information contained hereon reflects the Company's findings at the time of its intervention only and within the limits of Client's instructions, if any. The Company's sole responsibility is to its Client and this document does not exonerate parties to a transaction from exercising all their rights and obligations under the transaction documents. This document cannot be reproduced except in full, without prior written approval of the Company. Any unauthorized alteration, forgery or falsification of the content or appearance of this document is unlawful and offenders may be prosecuted to the fullest extent of the law. Unless otherwise stated the results shown in this test report refer only to the sample(s) tested.

Attention: To check the authenticity of testing /inspection report & certificate, please contact us at telephone: (86-755) 8307 1443, or email: [CN.Doccheck@sgs.com](mailto:CN.Doccheck@sgs.com)

SGS Standards Technical Services Co., Ltd  
Ningbo Branch

14/F West of Building 4, Lingyin Industry Park, No.1177 Lingyin Road, Ningbo National Hi-Tech Zone, Ningbo, Zhejiang, China 315040  
中国·浙江·宁波市国家高新区凌云路1177号凌云产业园4号楼西1-5层

315040 1 E&E (86-574)89070249 1 ML (86-574)89070242 www.sgsgroup.com.cn  
邮编: 315040 1 HL (86-574)89070271 1 TY (86-574)89070211 e sgs.china@sgs.com

DINP, DNOP, DIDP 参考信息: 1907/2006/EC Reach 附录XVII的修正指令——552/2009/EC 第52条 (前身为2005/84/EC) 的要求:

- i) 不允许DINP, DNOP, DIDP 质量浓度高于0.1%的可塑性物料用于可放入儿童口中的玩具和儿童护理品.
- ii) 当可放入儿童口中的玩具和儿童护理品中的可塑性物料含DINP, DNOP, DIDP 质量浓度高于0.1%时, 不得投放市场.

详细信息请参见Regulation (EC) No 552/2009

(2) \*此报告数据来源于NGBEC1602080903的报告, 日期2016/05/25

**全氟辛烷磺酸 (PFOS)和全氟辛酸(PFOA)**

测试方法: 参照US EPA 3550C: 2007. 采用HPLC-MS测试.

**测试项目**

全氟辛烷磺酸(PFOS)及衍生物<sup>^</sup>  
全氟辛酸 (PFOA)

| 单位    | MDL | 002 |
|-------|-----|-----|
| mg/kg | 10  | ND  |
| mg/kg | 10  | ND  |

**备注:**

(1) ^=全氟辛烷磺酸(PFOS)及其衍生物包含全氟辛烷磺酸(PFOS)、全氟辛基磺酰胺(PFOSA)、2- (N-乙基全氟辛基磺酰胺) 乙醇(EtFOSE)、N-甲基全氟辛烷磺酰胺(MeFOSA)、N-乙基全氟辛烷磺酰胺(EtFOSA)和2- (N-甲基全氟辛基磺酰胺) 乙醇(MeFOSE)。



Unless otherwise agreed in writing, this document is issued by the Company subject to its General Conditions of Service printed overleaf, available on request or accessible at <http://www.sgs.com/en/Terms-and-Conditions.aspx> and, for electronic format documents, subject to Terms and Conditions for Electronic Documents at <http://www.sgs.com/en/Terms-and-Conditions/Terms-e-Documents.aspx>. Attention is drawn to the limitation of liability, indemnification and jurisdiction issues defined therein. Any holder of this document is advised that information contained hereon reflects the Company's findings at the time of its intervention only and within the limits of Client's instructions, if any. The Company's sole responsibility is to its Client and this document does not exonerate parties to a transaction from exercising all their rights and obligations under the transaction documents. This document cannot be reproduced except in full, without prior written approval of the Company. Any unauthorized alteration, forgery or falsification of the content or appearance of this document is unlawful and offenders may be prosecuted to the fullest extent of the law. Unless otherwise stated the results shown in this test report refer only to the sample(s) tested.

Attention: To check the authenticity of testing /inspection report & certificate, please contact us at telephone: (86-755) 8307 1443, or email: [CN.Doccheck@sgs.com](mailto:CN.Doccheck@sgs.com)

SGS-CTC Standards Technical Services Co., Ltd 14/F West of Building 4, Lingyin Industry Park, No.1177 Lingyin Road, Ningbo National Hi-Tech Zone, Ningbo, Zhejiang, China 315040 T E&E (86-574)89070249 T ML (86-574)89070242 www.sgsgroup.com.cn  
中国·浙江·宁波市国家高新区凌云路1177号凌云产业园4号楼西1-5层 邮编: 315040 T HL (86-574)89070271 T TY (86-574)89070211 e sgs.china@sgs.com



附件:

1.0 1.25 DF14 GH ZH PH PA PHSD DF11 C1251 51146 FI-S  
 PHD YHD200 SMW SMH200 SMH200-H 20039WR 杜邦  
 2.0 XH/TJC3 XA HA XHB EH SZN SAN SCN SCND JC15 JC20  
 JC25 5264 250 LGC CH2.5 EI/小EP S11 HR 线扣 YH025 35155  
 5102 5240 SMH250 SMP250 SMW250 25048HS 25045HP  
 SM TJC8/杜邦2.54 TJC8A/杜邦带锁 TJC8B TJC8H 5051/2510 543  
 美尚美 CH10 25415 43645 43020 43025 5500  
 5600 VH VHRR/YH396 VHR 35156 2139/3.96 90331 5195 5196  
 39612 FL 5557 5559 5566 5569 42474 42475 SL RV42 CL014/OTP  
 EL YL 小型EL QH NV 50300 50301 8981/大四P 5058/5.08 5197  
 5198 5025 L6.2 VL VLP/VLR 3191 5199 TJC2 TJC2A TJC2B STV5  
 YHL500 YWL500 TJC4 TJC1 SMF Cy-X201/35108 35150 35151 35224  
 35180 35965 1806 110 2.8 42021 42022 42002 6.3 250 35955 SA  
 SCS 35189 35196 DF11 MX3.0  
 1.58 51005 51006 BH3.5 BH4.0 EL 63080 187 250 51004 TJC15  
 DF13 D4081 D4082 D6301 D6302 F1001-T11 SIN-T11 774-2P 774-3P  
 774-5P 2060-401 2060-402 2060-403 773-102 773-104 773-106 773-108  
 778 294 TU-JTK型叉型预绝缘端头 (SV) TU叉型裸端头 (SNB)  
 TO-JTK型圆形预绝缘端头 (RV) 公预绝缘接头 (MDD) 母预绝缘接头 (FDD)  
 TG-JT管型预绝缘端头 电缆防水接头 接线端子 软护套 IDC CONNECTOR AUTO  
 CONNECTOR DJ7021-1.5-11 DJ7021-1.5-21 DT04  
 DT06 UY/K1 UY2/K2 UR/K3 UR2 UB/K4 UB2A UG/K5 U1R/K8 U1B K9  
 HJKT10 UDW2 314



Unless otherwise agreed in writing, this document is issued by the Company subject to its General Conditions of Service printed overleaf, available on request or accessible at <http://www.sgs.com/en/Terms-and-Conditions.aspx> and, for electronic format documents, subject to Terms and Conditions for Electronic Documents at <http://www.sgs.com/en/Terms-and-Conditions/Terms-e-Documents.aspx>. Attention is drawn to the limitation of liability, indemnification and jurisdiction issues defined therein. Any holder of this document is advised that information contained hereon reflects the Company's findings at the time of its intervention only and within the limits of Client's instructions, if any. The Company's sole responsibility is to its Client and this document does not exonerate parties to a transaction from exercising all their rights and obligations under the transaction documents. This document cannot be reproduced except in full, without prior written approval of the Company. Any unauthorized alteration, forgery or falsification of the content or appearance of this document is unlawful and offenders may be prosecuted to the fullest extent of the law. Unless otherwise stated the results shown in this test report refer only to the sample(s) tested.

Attention: To check the authenticity of testing /inspection report & certificate, please contact us at telephone: (86-755) 8307 1443, or email: [CN.Doccheck@sgs.com](mailto:CN.Doccheck@sgs.com)

SGS (China) Standards Technical Services Co., Ltd. 14/F West of Building 4, Lingyin Industry Park, No.1177 Lingyin Road, Ningbo National Hi-Tech Zone, Ningbo, Zhejiang, China 315040 T E&E (86-574)89070249 T ML (86-574)89070242 www.sgsgroup.com.cn  
 中国·浙江·宁波市国家高新区凌云路1177号凌云产业园4号楼西1-5层 邮编: 315040 T HL (86-574)89070271 T TY (86-574)89070211 e sgs.china@sgs.com

## 邻苯测试流程图

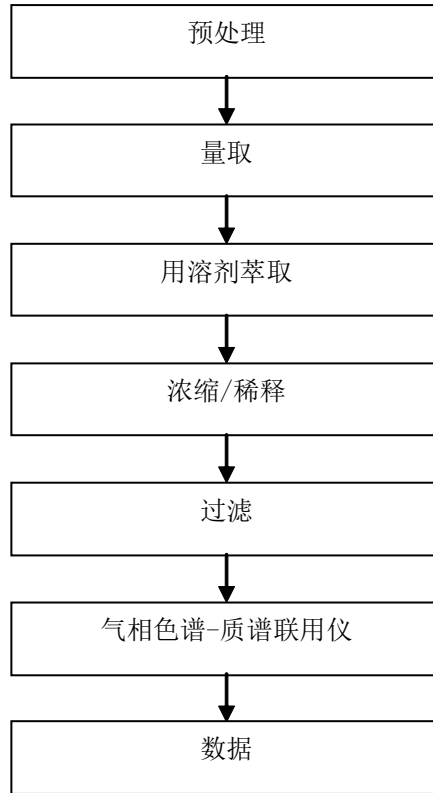

Unless otherwise agreed in writing, this document is issued by the Company subject to its General Conditions of Service printed overleaf, available on request or accessible at <http://www.sgs.com/en/Terms-and-Conditions.aspx> and, for electronic format documents, subject to Terms and Conditions for Electronic Documents at <http://www.sgs.com/en/Terms-and-Conditions/Terms-e-Documents.aspx>. Attention is drawn to the limitation of liability, indemnification and jurisdiction issues defined therein. Any holder of this document is advised that information contained hereon reflects the Company's findings at the time of its intervention only and within the limits of Client's instructions, if any. The Company's sole responsibility is to its Client and this document does not exonerate parties to a transaction from exercising all their rights and obligations under the transaction documents. This document cannot be reproduced except in full, without prior written approval of the Company. Any unauthorized alteration, forgery or falsification of the content or appearance of this document is unlawful and offenders may be prosecuted to the fullest extent of the law. Unless otherwise stated the results shown in this test report refer only to the sample(s) tested.

Attention: To check the authenticity of testing /inspection report & certificate, please contact us at telephone: (86-755) 8307 1443, or email: [CN.Doccheck@sgs.com](mailto:CN.Doccheck@sgs.com)

## 多环芳香烃测试流程图

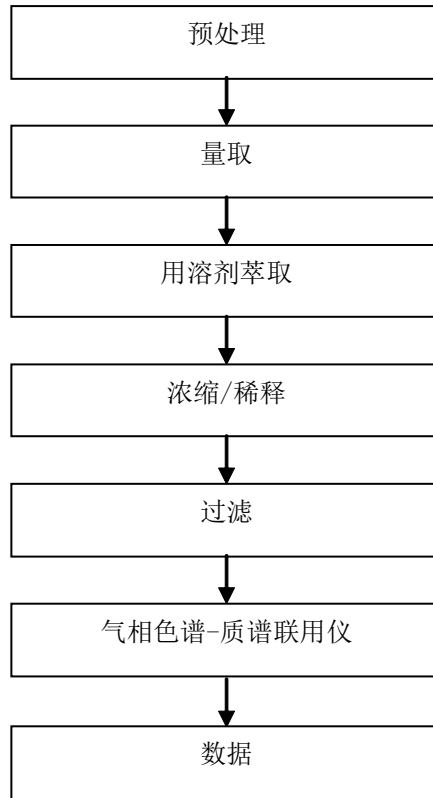

Unless otherwise agreed in writing, this document is issued by the Company subject to its General Conditions of Service printed overleaf, available on request or accessible at <http://www.sgs.com/en/Terms-and-Conditions.aspx> and, for electronic format documents, subject to Terms and Conditions for Electronic Documents at <http://www.sgs.com/en/Terms-and-Conditions/Terms-e-Documents.aspx>. Attention is drawn to the limitation of liability, indemnification and jurisdiction issues defined therein. Any holder of this document is advised that information contained hereon reflects the Company's findings at the time of its intervention only and within the limits of Client's instructions, if any. The Company's sole responsibility is to its Client and this document does not exonerate parties to a transaction from exercising all their rights and obligations under the transaction documents. This document cannot be reproduced except in full, without prior written approval of the Company. Any unauthorized alteration, forgery or falsification of the content or appearance of this document is unlawful and offenders may be prosecuted to the fullest extent of the law. Unless otherwise stated the results shown in this test report refer only to the sample(s) tested.

Attention: To check the authenticity of testing /inspection report & certificate, please contact us at telephone: (86-755) 8307 1443, or email: [CN.Doccheck@sgs.com](mailto:CN.Doccheck@sgs.com)

14/F West of Building 4, Lingyin Industry Park, No.1177 Lingyin Road, Ningbo National Hi-Tech Zone, Ningbo, Zhejiang, China 315040 T E&E (86-574)89070249 T ML (86-574)89070242 www.sgsgroup.com.cn  
中国·浙江·宁波市国家高新区凌云路1177号凌云产业园4号楼西1-5层 邮编: 315040 T HL (86-574)89070271 T TY (86-574)89070211 e sgs.china@sgs.com

全氟辛烷磺酰基化合物/全氟辛酸测试流程图

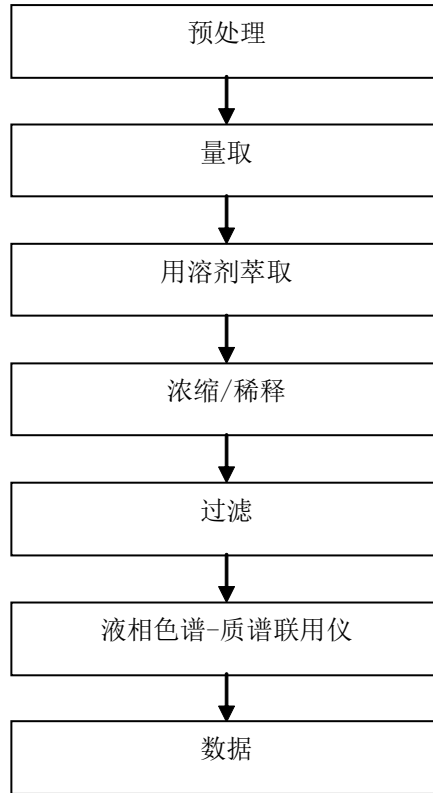

Unless otherwise agreed in writing, this document is issued by the Company subject to its General Conditions of Service printed overleaf, available on request or accessible at <http://www.sgs.com/en/Terms-and-Conditions.aspx> and, for electronic format documents, subject to Terms and Conditions for Electronic Documents at <http://www.sgs.com/en/Terms-and-Conditions/Terms-e-Documents.aspx>. Attention is drawn to the limitation of liability, indemnification and jurisdiction issues defined therein. Any holder of this document is advised that information contained hereon reflects the Company's findings at the time of its intervention only and within the limits of Client's instructions, if any. The Company's sole responsibility is to its Client and this document does not exonerate parties to a transaction from exercising all their rights and obligations under the transaction documents. This document cannot be reproduced except in full, without prior written approval of the Company. Any unauthorized alteration, forgery or falsification of the content or appearance of this document is unlawful and offenders may be prosecuted to the fullest extent of the law. Unless otherwise stated the results shown in this test report refer only to the sample(s) tested.

Attention: To check the authenticity of testing /inspection report & certificate, please contact us at telephone: (86-755) 8307 1443, or email: [CN.Doccheck@sgs.com](mailto:CN.Doccheck@sgs.com)

## 卤素测试流程图

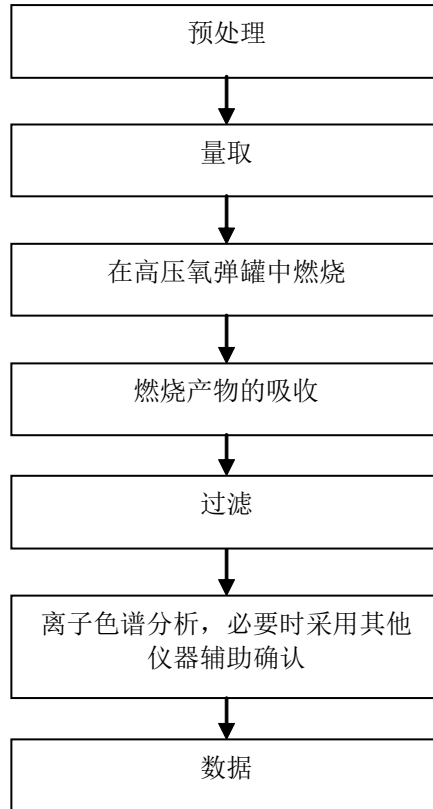

Unless otherwise agreed in writing, this document is issued by the Company subject to its General Conditions of Service printed overleaf, available on request or accessible at <http://www.sgs.com/en/Terms-and-Conditions.aspx> and, for electronic format documents, subject to Terms and Conditions for Electronic Documents at <http://www.sgs.com/en/Terms-and-Conditions/Terms-e-Documents.aspx>. Attention is drawn to the limitation of liability, indemnification and jurisdiction issues defined therein. Any holder of this document is advised that information contained hereon reflects the Company's findings at the time of its intervention only and within the limits of Client's instructions, if any. The Company's sole responsibility is to its Client and this document does not exonerate parties to a transaction from exercising all their rights and obligations under the transaction documents. This document cannot be reproduced except in full, without prior written approval of the Company. Any unauthorized alteration, forgery or falsification of the content or appearance of this document is unlawful and offenders may be prosecuted to the fullest extent of the law. Unless otherwise stated the results shown in this test report refer only to the sample(s) tested.

Attention: To check the authenticity of testing /inspection report & certificate, please contact us at telephone: (86-755) 8307 1443, or email: [CN.Doccheck@sgs.com](mailto:CN.Doccheck@sgs.com)

SGS Standards Technical Services Co., Ltd. 14/F West of Building 4, Lingyin Industry Park, No.1177 Lingyin Road, Ningbo National Hi-Tech Zone, Ningbo, Zhejiang, China 315040 T E&E (86-574)89070249 T ML (86-574)89070242 www.sgs.com.cn  
 中国·浙江·宁波市国家高新区凌云路1177号凌云产业园4号楼西1-5层 邮编: 315040 T HL (86-574)89070271 T TY (86-574)89070211 e sgs.china@sgs.com

样品照片:

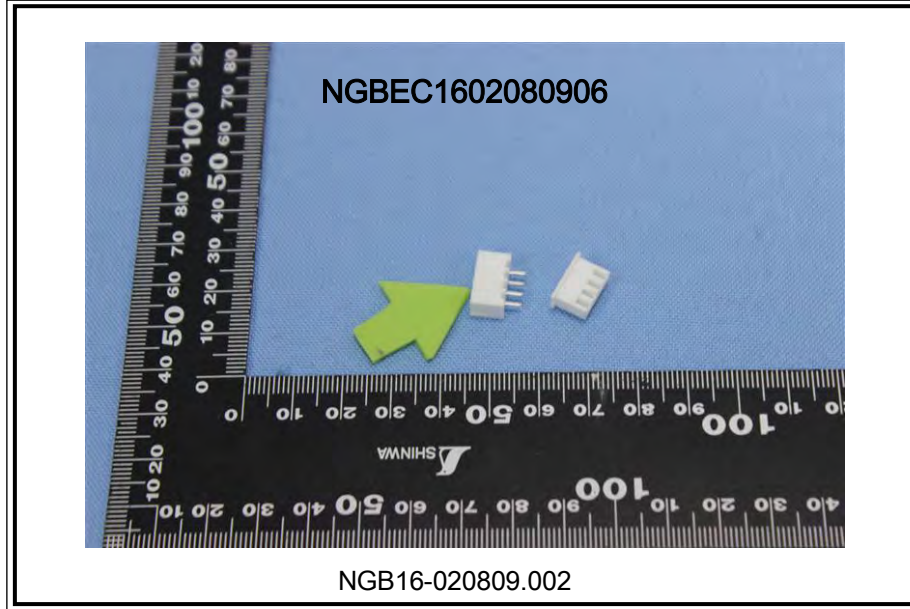

此照片仅限于随SGS正本报告使用

\*\*\* 报告完 \*\*\*



Unless otherwise agreed in writing, this document is issued by the Company subject to its General Conditions of Service printed overleaf, available on request or accessible at <http://www.sgs.com/en/Terms-and-Conditions.aspx> and, for electronic format documents, subject to Terms and Conditions for Electronic Documents at <http://www.sgs.com/en/Terms-and-Conditions/Terms-e-Documents.aspx>. Attention is drawn to the limitation of liability, indemnification and jurisdiction issues defined therein. Any holder of this document is advised that information contained hereon reflects the Company's findings at the time of its intervention only and within the limits of Client's instructions, if any. The Company's sole responsibility is to its Client and this document does not exonerate parties to a transaction from exercising all their rights and obligations under the transaction documents. This document cannot be reproduced except in full, without prior written approval of the Company. Any unauthorized alteration, forgery or falsification of the content or appearance of this document is unlawful and offenders may be prosecuted to the fullest extent of the law. Unless otherwise stated the results shown in this test report refer only to the sample(s) tested.

Attention: To check the authenticity of testing / inspection report & certificate, please contact us at telephone: (86-755) 8307 1443, or email: [CN.Doccheck@sgs.com](mailto:CN.Doccheck@sgs.com)

SGS-CTI Standards Technical Services Co., Ltd  
Ningbo Branch

1-6F West of Building 4, Lingyin Industry Park, No.1177 Lingyin Road, Ningbo National Hi-Tech Zone, Ningbo, Zhejiang, China 315040 T E&E (86-574)89070249 T ML (86-574)89070242 www.sgsgroup.com.cn  
中国·浙江·宁波市国家高新区凌云路1177号凌云产业园4号楼西1-5层 邮编: 315040 T HL (86-574)89070271 T TY (86-574)89070211 e [sgs.china@sgs.com](mailto:sgs.china@sgs.com)

以下测试之样品是由申请者所提供及确认:连接器

SGS工作编号: NP16-003773 - NB

型号: 1.25

客户参考信息: 见附件

样品接收日期: 2016年09月02日

测试周期: 2016年09月02日 - 2016年09月08日

测试要求: 根据客户要求测试

测试方法: 请参见下一页

测试结果: 请参见下一页

结论: 基于所送样品的指定部位进行的测试, 镉、铅、汞、六价铬、多溴联苯(PBBs)、多溴二苯醚(PBDEs)、邻苯二甲酸酯(如邻苯二甲酸二丁酯(DBP)、邻苯二甲酸丁苄酯(BBP)、邻苯二甲酸二(2-乙基己基)酯(DEHP)和邻苯二甲酸二异丁酯(DIBP))的测试结果符合欧盟RoHS指令2011/65/EU附录II的修正指令(EU) 2015/863的限值要求。

通标标准技术服务有限公司宁波分公司  
授权签名

Iris Xiao 肖玲艳  
批准签署人

本报告是编号为NGBEC1604223903报告的中文版本



Unless otherwise agreed in writing, this document is issued by the Company subject to its General Conditions of Service printed overleaf, available on request or accessible at <http://www.sgs.com/en/Terms-and-Conditions.aspx> and, for electronic format documents, subject to Terms and Conditions for Electronic Documents at <http://www.sgs.com/en/Terms-and-Conditions/Terms-e-Documents.aspx>. Attention is drawn to the limitation of liability, indemnification and jurisdiction issues defined therein. Any holder of this document is advised that information contained hereon reflects the Company's findings at the time of its intervention only and within the limits of Client's instructions, if any. The Company's sole responsibility is to its Client and this document does not exonerate parties to a transaction from exercising all their rights and obligations under the transaction documents. This document cannot be reproduced except in full, without prior written approval of the Company. Any unauthorized alteration, forgery or falsification of the content or appearance of this document is unlawful and offenders may be prosecuted to the fullest extent of the law. Unless otherwise stated the results shown in this test report refer only to the sample(s) tested.

Attention: To check the authenticity of testing /inspection report & certificate, please contact us at telephone: (86-755) 8307 1443, or email: [CN.Doccheck@sgs.com](mailto:CN.Doccheck@sgs.com)

SGS-CSTC Inspection & Testing Services Co., Ltd.  
Ningbo Branch Chemical Laboratory

15F West of Building 4, Lingyun Industry Park, No.1177 Lingyun Road, Ningbo National Hi-Tech Zone, Ningbo, Zhejiang, China 315040 t E&E (86-574)89070249  
中国·浙江·宁波市国家高新区凌云路1177号凌云产业园4号楼西1-5层 邮编: 315040 t HL (86-574)89070271 t ML (86-574)89070242 e [sgs.china@sgs.com](mailto:sgs.china@sgs.com)

[www.sgs.com](http://www.sgs.com)

# 测试报告

No. NGBEC1604223904

日期: 2016年09月09日

第2页,共8页

测试结果:

## 测试样品描述:

| 样品编号 | SGS样品ID          | 描述     |
|------|------------------|--------|
| SN1  | NGB16-042239.002 | 白色塑料部分 |

备注:

- (1) 1 mg/kg = 0.0001%
- (2) MDL = 方法检测限
- (3) ND = 未检出 (< MDL)
- (4) "-" = 未规定

## RoHS 指令2011/65/EU附录II的修正指令(EU) 2015/863

- 测试方法:
- (1) 参考IEC 62321-5:2013, 用ICP-OES测定镉的含量
  - (2) 参考IEC 62321-5:2013, 用ICP-OES测定铅的含量
  - (3) 参考IEC 62321-4:2013, 用ICP-OES测定汞的含量
  - (4) 参考IEC 62321:2008, 用紫外-可见分光光度计比色法测定六价铬的含量
  - (5) 参考IEC 62321-6:2015, 用GC-MS测定PBBs(多溴联苯)和PBDEs(多溴二苯醚)的含量
  - (6) 参考IEC 62321-8:2013 (111/321/CD), 用GC-MS测定邻苯二甲酸酯的含量

| 测试项目           | 限值   | 单位    | MDL | 002 |
|----------------|------|-------|-----|-----|
| 镉(Cd)          | 100  | mg/kg | 2   | ND  |
| 铅(Pb)          | 1000 | mg/kg | 2   | ND  |
| 汞(Hg)          | 1000 | mg/kg | 2   | ND  |
| 六价铬(CrVI)      | 1000 | mg/kg | 2   | ND  |
| 多溴联苯(PBBs)之和   | 1000 | mg/kg | -   | ND  |
| 一溴联苯           | -    | mg/kg | 5   | ND  |
| 二溴联苯           | -    | mg/kg | 5   | ND  |
| 三溴联苯           | -    | mg/kg | 5   | ND  |
| 四溴联苯           | -    | mg/kg | 5   | ND  |
| 五溴联苯           | -    | mg/kg | 5   | ND  |
| 六溴联苯           | -    | mg/kg | 5   | ND  |
| 七溴联苯           | -    | mg/kg | 5   | ND  |
| 八溴联苯           | -    | mg/kg | 5   | ND  |
| 九溴联苯           | -    | mg/kg | 5   | ND  |
| 十溴联苯           | -    | mg/kg | 5   | ND  |
| 多溴二苯醚之和(PBDEs) | 1000 | mg/kg | -   | ND  |
| 一溴二苯醚          | -    | mg/kg | 5   | ND  |
| 二溴二苯醚          | -    | mg/kg | 5   | ND  |



Unless otherwise agreed in writing, this document is issued by the Company subject to its General Conditions of Service printed overleaf, available on request or accessible at <http://www.sgs.com/en/Terms-and-Conditions.aspx> and, for electronic format documents, subject to Terms and Conditions for Electronic Documents at <http://www.sgs.com/en/Terms-and-Conditions/Terms-e-Documents.aspx>. Attention is drawn to the limitation of liability, indemnification and jurisdiction issues defined therein. Any holder of this document is advised that information contained hereon reflects the Company's findings at the time of its intervention only and within the limits of Client's instructions, if any. The Company's sole responsibility is to its Client and this document does not exonerate parties to a transaction from exercising all their rights and obligations under the transaction documents. This document cannot be reproduced except in full, without prior written approval of the Company. Any unauthorized alteration, forgery or falsification of the content or appearance of this document is unlawful and offenders may be prosecuted to the fullest extent of the law. Unless otherwise stated the results shown in this test report refer only to the sample(s) tested.

Attention: To check the authenticity of testing / inspection report & certificate, please contact us at telephone: (86-755) 8307 1443, or email: [CN.Doccheck@sgs.com](mailto:CN.Doccheck@sgs.com)

SGS-CSTC 宁波检测有限公司  
Inspection & Testing Services  
Ningbo Branch Chemical Laboratory

15F West of Building 4, Lingyun Industry Park, No.1177 Lingyun Road, Ningbo National Hi-Tech Zone, Ningbo, Zhejiang, China 315040  
中国·浙江·宁波市国家高新区凌云路1177号凌云产业园4号楼西1-5层

www.sgsgroup.com.cn

t E&E (86-574)89070249 t ML (86-574)89070242 e sgs.china@sgs.com  
t HL (86-574)89070271



## 测试报告

No. NGBEC1604223904

日期: 2016年09月09日

第3页,共8页

| 测试项目                  | 限值   | 单位    | MDL | 002 |
|-----------------------|------|-------|-----|-----|
| 三溴二苯醚                 | -    | mg/kg | 5   | ND  |
| 四溴二苯醚                 | -    | mg/kg | 5   | ND  |
| 五溴二苯醚                 | -    | mg/kg | 5   | ND  |
| 六溴二苯醚                 | -    | mg/kg | 5   | ND  |
| 七溴二苯醚                 | -    | mg/kg | 5   | ND  |
| 八溴二苯醚                 | -    | mg/kg | 5   | ND  |
| 九溴二苯醚                 | -    | mg/kg | 5   | ND  |
| 十溴二苯醚                 | -    | mg/kg | 5   | ND  |
| 邻苯二甲酸二丁酯 (DBP)        | 1000 | mg/kg | 50  | ND  |
| 邻苯二甲酸丁苄酯(BBP)         | 1000 | mg/kg | 50  | ND  |
| 邻苯二甲酸二(2-乙基己基)酯(DEHP) | 1000 | mg/kg | 50  | ND  |
| 邻苯二甲酸二异丁酯(DIBP)       | 1000 | mg/kg | 50  | ND  |

备注:

(1) 最大允许极限值引用自RoHS指令(EU) 2015/863。

## 卤素

测试方法: 参照EN 14582:2007方法测定, 采用IC进行分析。

| 测试项目  | 单位    | MDL | 002 |
|-------|-------|-----|-----|
| 氟(F)  | mg/kg | 50  | 792 |
| 氯(Cl) | mg/kg | 50  | ND  |
| 溴(Br) | mg/kg | 50  | ND  |
| 碘(I)  | mg/kg | 50  | ND  |



SGS-CSTC 标榜检测服务有限公司  
Inspection & Testing Services  
Ningbo Branch Chemical Laboratory

Unless otherwise agreed in writing, this document is issued by the Company subject to its General Conditions of Service printed overleaf, available on request or accessible at <http://www.sgs.com/en/Terms-and-Conditions.aspx> and, for electronic format documents, subject to Terms and Conditions for Electronic Documents at <http://www.sgs.com/en/Terms-and-Conditions/Terms-e-Documents.aspx>. Attention is drawn to the limitation of liability, indemnification and jurisdiction issues defined therein. Any holder of this document is advised that information contained hereon reflects the Company's findings at the time of its intervention only and within the limits of Client's instructions, if any. The Company's sole responsibility is to its Client and this document does not exonerate parties to a transaction from exercising all their rights and obligations under the transaction documents. This document cannot be reproduced except in full, without prior written approval of the Company. Any unauthorized alteration, forgery or falsification of the content or appearance of this document is unlawful and offenders may be prosecuted to the fullest extent of the law. Unless otherwise stated the results shown in this test report refer only to the sample(s) tested.

Attention: To check the authenticity of testing /inspection report & certificate, please contact us at telephone: (86-755) 8307 1443, or email: [CN.Doccheck@sgs.com](mailto:CN.Doccheck@sgs.com)

15/F West of Building 4, Lingyun Industry Park, No.1177 Lingyun Road, Ningbo National Hi-Tech Zone, Ningbo, Zhejiang, China 315040 t E&E (86-574)89070249  
中国·浙江·宁波市国家高新区凌云路1177号凌云产业园4号楼西1-5层 邮编: 315040 t HL (86-574)89070271 t ML (86-574)89070242 e [sgs.china@sgs.com](mailto:sgs.china@sgs.com)

[www.sgs.com](http://www.sgs.com)

附件:

1.0 1.25 DF14 GH ZH PH PA PHSD DF11 C1251 51146 FI-S PHD YHD200 SMW SMH200  
 SMH200-H 20039WR SAN 杜邦2.0 XH/TJC3 XA HA XHB EH SCN SCND JC20 JC25 5264 250 LGC  
 CH2.5 EI/小EP S11 HR 线扣 YH025 35155 5102 5240 SMH250 SMP250 SMW250 25048HS 25045HP SM  
 TJC8/杜邦2.54 TJC8A/杜邦带锁 TJC8B TJC8H 5051/2510 543 美尚美 CH10 25415 43645 43020 43025 5500  
 5600 VH VHRR/YH396 VHR 35156 2139/3.96 90331 5195 5196 39612 FL 5557 5559 5566 5569 42474  
 42475 SL RV42 CL014/OTP EL YL 小型EL QH NV 50300 50301 8981/大四P 5058/5.08 5197 5198 5025  
 L6.2 VL VLP/MLR 3191 5199 TJC2 TJC2A TJC2B STV5 YHL500 YWL500 TJC4 TJC1 SMF  
 Cy-X201/35108 35150 35151 35224 35180 35965 1806 110 2.8 42021 42022 42002 6.3 250 35955 SA  
 SCS 35189 35196 DF11 MX3.0 1.58 51005 51006 BH3.5 BH4.0 EL 63080 187 250



SGS-CS10 (China) Inspection & Testing Services Co., Ltd.  
 Ningbo Branch Chemical Laboratory

Unless otherwise agreed in writing, this document is issued by the Company subject to its General Conditions of Service printed overleaf, available on request or accessible at <http://www.sgs.com/en/Terms-and-Conditions.aspx> and, for electronic format documents, subject to Terms and Conditions for Electronic Documents at <http://www.sgs.com/en/Terms-and-Conditions/Terms-e-Documents.aspx>. Attention is drawn to the limitation of liability, indemnification and jurisdiction issues defined therein. Any holder of this document is advised that information contained hereon reflects the Company's findings at the time of its intervention only and within the limits of Client's instructions, if any. The Company's sole responsibility is to its Client and this document does not exonerate parties to a transaction from exercising all their rights and obligations under the transaction documents. This document cannot be reproduced except in full, without prior written approval of the Company. Any unauthorized alteration, forgery or falsification of the content or appearance of this document is unlawful and offenders may be prosecuted to the fullest extent of the law. Unless otherwise stated the results shown in this test report refer only to the sample(s) tested.

Attention: To check the authenticity of testing /inspection report & certificate, please contact us at telephone: (86-755) 8307 1443, or email: [CN.Doccheck@sgs.com](mailto:CN.Doccheck@sgs.com)

15F West of Building 4, Lingyun Industry Park, No.1177 Lingyun Road, Ningbo National Hi-Tech Zone, Ningbo, Zhejiang, China 315040 t E&E (86-574)89070249 www.sgs.com  
 中国·浙江·宁波市国家高新区凌云路1177号凌云产业园4号楼西1-5层 邮编: 315040 t HL (86-574)89070271 t ML (86-574)89070242 e sgs.china@sgs.com

附件

RoHS 测试流程图

1) 样品按照下述流程被完全消解（六价铬和多溴联苯/多溴二苯醚测试除外）。

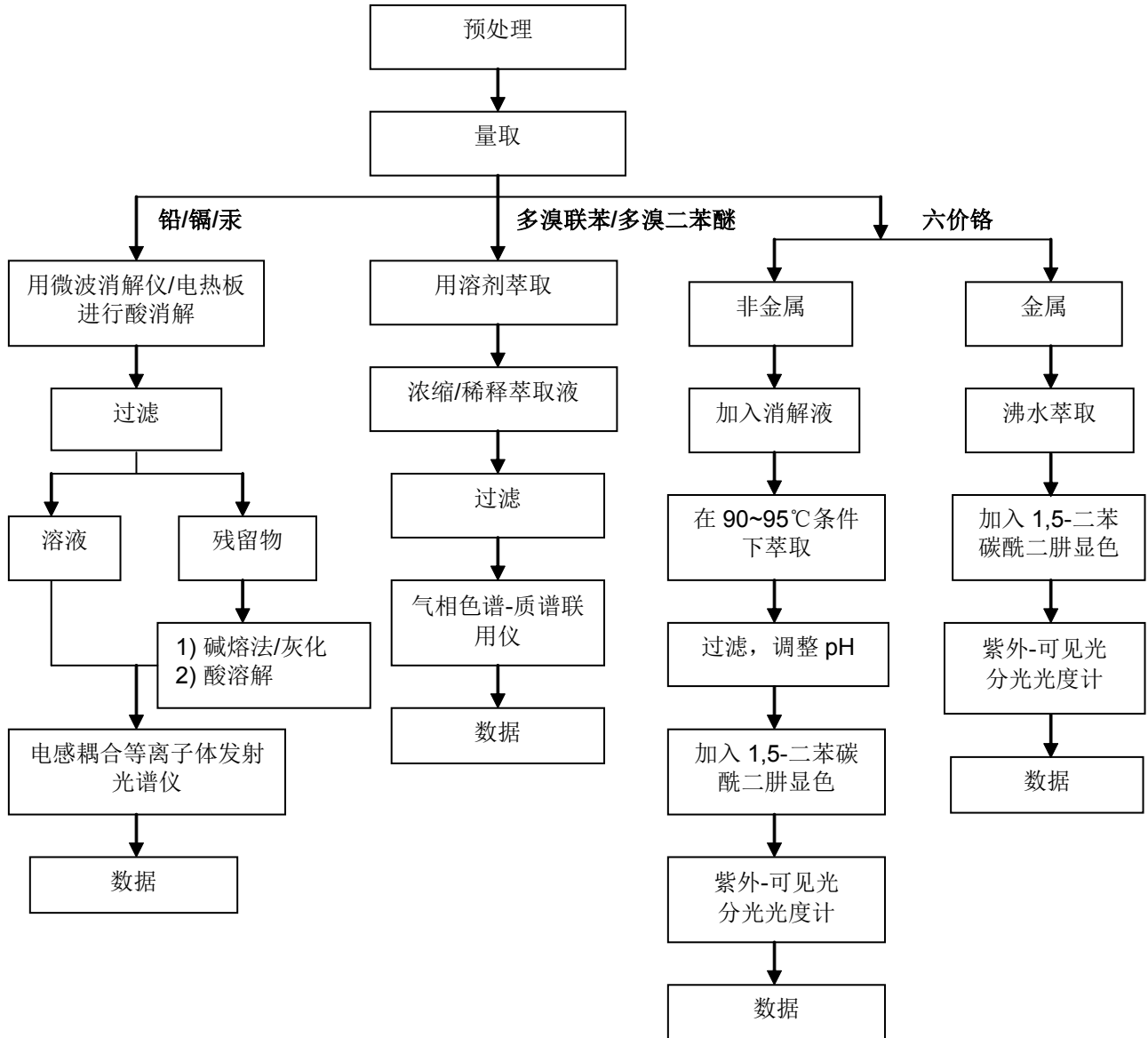

Unless otherwise agreed in writing, this document is issued by the Company subject to its General Conditions of Service printed overleaf, available on request or accessible at <http://www.sgs.com/en/Terms-and-Conditions.aspx> and, for electronic format documents, subject to Terms and Conditions for Electronic Documents at <http://www.sgs.com/en/Terms-and-Conditions/Terms-e-Document.aspx>. Attention is drawn to the limitation of liability, indemnification and jurisdiction issues defined therein. Any holder of this document is advised that information contained hereon reflects the Company's findings at the time of its intervention only and within the limits of Client's instructions, if any. The Company's sole responsibility is to its Client and this document does not exonerate parties to a transaction from exercising all their rights and obligations under the transaction documents. This document cannot be reproduced except in full, without prior written approval of the Company. Any unauthorized alteration, forgery or falsification of the content or appearance of this document is unlawful and offenders may be prosecuted to the fullest extent of the law. Unless otherwise stated the results shown in this test report refer only to the sample(s) tested.

Attention: To check the authenticity of testing /inspection report & certificate, please contact us at telephone: (86-755) 8307 1443, or email: [CN.Doccheck@sgs.com](mailto:CN.Doccheck@sgs.com)

SGS-CSTC 宁波检测有限公司  
Inspection & Testing Services  
Ningbo Branch Chemical Laboratory

15F West of Building 4, Lingyun Industry Park, No.1177 Lingyun Road, Ningbo National Hi-Tech Zone, Ningbo, Zhejiang, China 315040 t E&E (86-574)89070249  
中国·浙江·宁波市国家高新区凌云路1177号凌云产业园4号楼西1-5层 邮编: 315040 t HL (86-574)89070271 t ML (86-574)89070242 e [sgs.china@sgs.com](mailto:sgs.china@sgs.com)

[www.sgs.com](http://www.sgs.com)

## 邻苯测试流程图

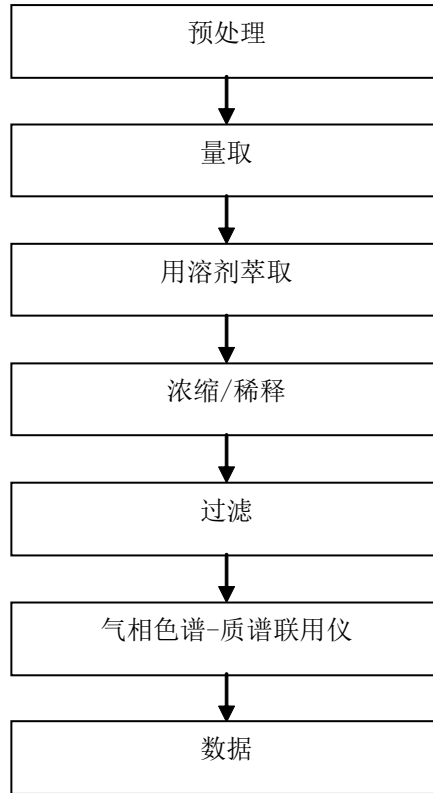

## 卤素测试流程图

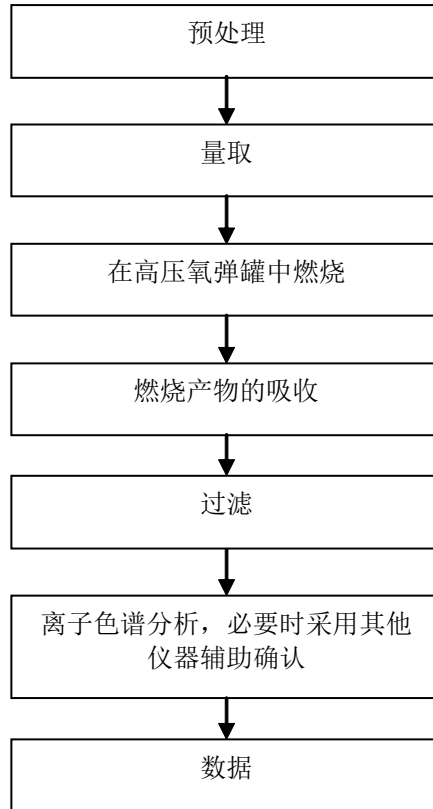

样品照片:

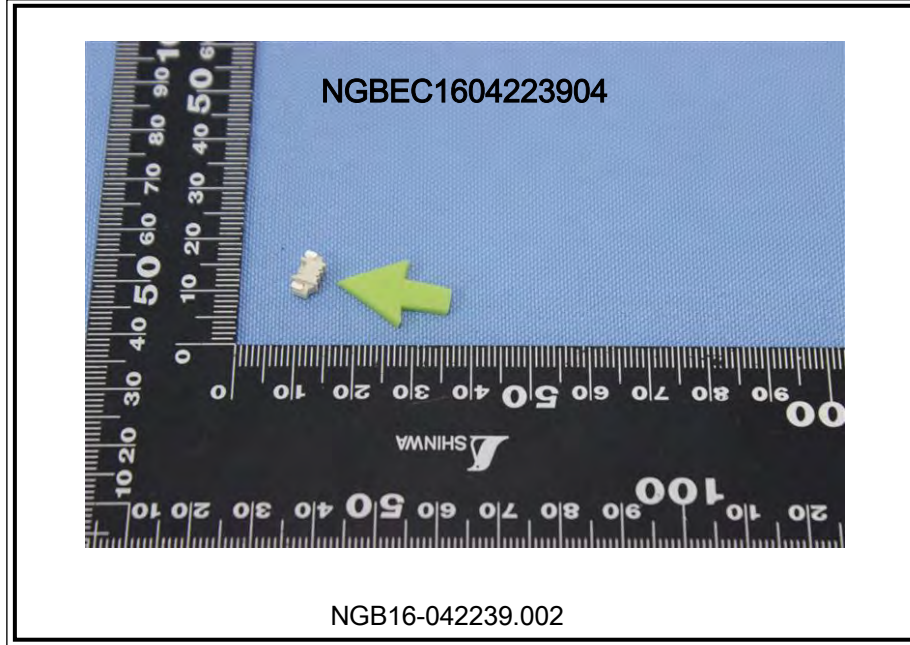

此照片仅限于随SGS正本报告使用

\*\*\* 报告完 \*\*\*



Unless otherwise agreed in writing, this document is issued by the Company subject to its General Conditions of Service printed overleaf, available on request or accessible at <http://www.sgs.com/en/Terms-and-Conditions.aspx> and, for electronic format documents, subject to Terms and Conditions for Electronic Documents at <http://www.sgs.com/en/Terms-and-Conditions/Terms-e-Documents.aspx>. Attention is drawn to the limitation of liability, indemnification and jurisdiction issues defined therein. Any holder of this document is advised that information contained hereon reflects the Company's findings at the time of its intervention only and within the limits of Client's instructions, if any. The Company's sole responsibility is to its Client and this document does not exonerate parties to a transaction from exercising all their rights and obligations under the transaction documents. This document cannot be reproduced except in full, without prior written approval of the Company. Any unauthorized alteration, forgery or falsification of the content or appearance of this document is unlawful and offenders may be prosecuted to the fullest extent of the law. Unless otherwise stated the results shown in this test report refer only to the sample(s) tested.

Attention: To check the authenticity of testing /inspection report & certificate, please contact us at telephone: (86-755) 8307 1443, or email: [CN.Doccheck@sgs.com](mailto:CN.Doccheck@sgs.com)

SGS-CSTC 宁波技术服务有限公司  
Inspection & Testing Services  
Ningbo Branch Laboratory

15F West of Building 4, Lingyun Industry Park, No.1177 Lingyun Road, Ningbo National Hi-Tech Zone, Ningbo, Zhejiang, China 315040 t E&E (86-574)89070249 www.sgsgroup.com.cn  
中国·浙江·宁波市国家高新区凌云路1177号凌云产业园4号楼西1-5层 邮编: 315040 t HL (86-574)89070271 t ML (86-574)89070242 e sgs.china@sgs.com

## 测试报告

No. NGBEC1602080902

日期: 2016年05月25日

第1页,共5页

浙江联和电子有限公司  
浙江省乐清市石帆镇后屿村

以下测试之样品是由申请者所提供及确认: 端子

SGS工作编号: NP16-001905 - NB  
主要成分: 锡 铜  
型号: XH  
客户参考信息: 见附件  
样品接收日期: 2016年05月16日  
测试周期: 2016年05月16日 - 2016年05月20日  
测试要求: 根据客户要求测试  
测试方法: 请参见下一页  
测试结果: 请参见下一页  
结论: 基于所送样品进行的测试, 镉、铅、汞、六价铬的测试结果符合欧盟RoHS指令2011/65/EU附录II的修正指令(EU) 2015/863的限值要求。

通标标准技术服务有限公司宁波分公司  
授权签名

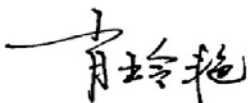

Iris Xiao 肖玲艳  
批准签署人

本报告是编号为NGBEC1602080901 报告的中文版本



Unless otherwise agreed in writing, this document is issued by the Company subject to its General Conditions of Service printed overleaf, available on request or accessible at <http://www.sgs.com/en/Terms-and-Conditions.aspx> and, for electronic format documents, subject to Terms and Conditions for Electronic Documents at <http://www.sgs.com/en/Terms-and-Conditions/Terms-e-Documents.aspx>. Attention is drawn to the limitation of liability, indemnification and jurisdiction issues defined therein. Any holder of this document is advised that information contained hereon reflects the Company's findings at the time of its intervention only and within the limits of Client's instructions, if any. The Company's sole responsibility is to its Client and this document does not exonerate parties to a transaction from exercising all their rights and obligations under the transaction documents. This document cannot be reproduced except in full, without prior written approval of the Company. Any unauthorized alteration, forgery or falsification of the content or appearance of this document is unlawful and offenders may be prosecuted to the fullest extent of the law. Unless otherwise stated the results shown in this test report refer only to the sample(s) tested.

Attention: To check the authenticity of testing /inspection report & certificate, please contact us at telephone: (86-755) 8307 1443, or email: [CN.Doccheck@sgs.com](mailto:CN.Doccheck@sgs.com)

SGS-CTI Standards Technical Services Co., Ltd  
Ningbo Branch

1-6/F West of Building 4, Lingyin Industry Park, No.1177 Lingyin Road, Ningbo National Hi-Tech Zone, Ningbo, Zhejiang, China 315040 T E&E (86-574)89070249 T ML (86-574)89070242 www.sgsgroup.com.cn  
中国·浙江·宁波市国家高新区凌云路1177号凌云产业园4号楼西1-5层 邮编: 315040 T HL (86-574)89070271 T TY (86-574)89070211 e [sgs.china@sgs.com](mailto:sgs.china@sgs.com)

# 测试报告

No. NGBEC1602080902

日期: 2016年05月25日

第2页,共5页

测试结果:

测试样品描述:

| 样品编号 | SGS样品ID          | 描述   |
|------|------------------|------|
| SN1  | NGB16-020809.001 | 银色金属 |

备注:

- (1) 1 mg/kg = 0.0001%
- (2) MDL = 方法检测限
- (3) ND = 未检出 (< MDL)
- (4) "-" = 未规定

## RoHS指令2011/65/EU附录II的修正指令(EU) 2015/863

- 测试方法:
- (1) 参考IEC 62321-5:2013, 用ICP-OES测定镉的含量
  - (2) 参考IEC 62321-5:2013, 用ICP-OES测定铅的含量
  - (3) 参考IEC 62321-4:2013, 用ICP-OES测定汞的含量
  - (4) 参考IEC 62321-7-1:2015, 用紫外-可见分光光度计比色法测定六价铬的含量

| 测试项目          | 限值   | 单位                 | MDL  | 001 |
|---------------|------|--------------------|------|-----|
| 镉 (Cd)        | 100  | mg/kg              | 2    | ND  |
| 铅 (Pb)        | 1000 | mg/kg              | 2    | 15  |
| 汞 (Hg)        | 1000 | mg/kg              | 2    | ND  |
| 六价铬 (Cr(VI))▼ | -    | µg/cm <sup>2</sup> | 0.10 | ND  |

备注:

- (1) 最大允许极限值引用自RoHS指令(EU) 2015/863.
- (2) ▼ = a. 当六价铬的浓度高于0.13 µg/cm<sup>2</sup>时, 样品为阳性, 即含有六价铬;  
 b. 当六价铬的浓度为ND(低于0.10 µg/cm<sup>2</sup>)时, 样品为阴性, 即未检测到六价铬;  
 c. 当六价铬的浓度介于0.10 µg/cm<sup>2</sup>与0.13 µg/cm<sup>2</sup>之间时, 无法直接判定是否检测到六价铬, 因不同个体的样品表面差异可能会影响测定结果;

由于未获知样品的存储条件和生产日期, 样品的六价铬测试结果仅能代表测试时样品含六价铬的状态。

IEC 62321系列等同于 EN 62321系列

[http://www.cenelec.eu/dyn/www/f?p=104:30:1742232870351101:::FSP\\_ORG\\_ID,FSP\\_LANG\\_ID:125863,7,25](http://www.cenelec.eu/dyn/www/f?p=104:30:1742232870351101:::FSP_ORG_ID,FSP_LANG_ID:125863,7,25)



Unless otherwise agreed in writing, this document is issued by the Company subject to its General Conditions of Service printed overleaf, available on request or accessible at <http://www.sgs.com/en/Terms-and-Conditions.aspx> and, for electronic format documents, subject to Terms and Conditions for Electronic Documents at <http://www.sgs.com/en/Terms-and-Conditions/Terms-e-Documents.aspx>. Attention is drawn to the limitation of liability, indemnification and jurisdiction issues defined therein. Any holder of this document is advised that information contained hereon reflects the Company's findings at the time of its intervention only and within the limits of Client's instructions, if any. The Company's sole responsibility is to its Client and this document does not exonerate parties to a transaction from exercising all their rights and obligations under the transaction documents. This document cannot be reproduced except in full, without prior written approval of the Company. Any unauthorized alteration, forgery or falsification of the content or appearance of this document is unlawful and offenders may be prosecuted to the fullest extent of the law. Unless otherwise stated the results shown in this test report refer only to the sample(s) tested.

Attention: To check the authenticity of testing /inspection report & certificate, please contact us at telephone: (86-755) 8307 1443, or email: [CN.Doccheck@sgs.com](mailto:CN.Doccheck@sgs.com)

SGS-1602 Standards Technical Services Co., Ltd. 1-6/F West of Building 4, Lingyin Industry Park, No.1177 Lingyin Road, Ningbo National Hi-Tech Zone, Ningbo, Zhejiang, China 315040 T E&E (86-574)89070249 T ML (86-574)89070242 www.sgs.com.cn  
 中国·浙江·宁波市国家高新区凌云路1177号凌云产业园4号楼西1-5层 邮编: 315040 T HL (86-574)89070271 T TY (86-574)89070211 e sgs.china@sgs.com



附件:

1.0 1.25 DF14 GH ZH PH PA PHSD DF11 C1251 51146 FI-S  
PHD YHD200 SMW SMH200 SMH200-H 20039WR 杜邦  
2.0 XH/TJC3 XA HA XHB EH SZN SAN SCN SCND JC15 JC20  
JC25 5264 250 LGC CH2.5 EI/小EP S11 HR 线扣 YH025 35155  
5102 5240 SMH250 SMP250 SMW250 25048HS 25045HP  
SM TJC8/杜邦2.54 TJC8A/杜邦带锁 TJC8B TJC8H 5051/2510 543  
美尚美 CH10 25415 43645 43020 43025 5500  
5600 VH VHRR/YH396 VHR 35156 2139/3.96 90331 5195 5196  
39612 FL 5557 5559 5566 5569 42474 42475 SL RV42 CL014/OTP  
EL YL 小型EL QH NV 50300 50301 8981/大四P 5058/5.08 5197  
5198 5025 L6.2 VL VLP/VLR 3191 5199 TJC2 TJC2A TJC2B STV5  
YHL500 YWL500 TJC4 TJC1 SMF Cy-X201/35108 35150 35151 35224  
35180 35965 1806 110 2.8 42021 42022 42002 6.3 250 35955 SA  
SCS 35189 35196 DF11 MX3.0  
1.58 51005 51006 BH3.5 BH4.0 EL 63080 187 250 51004 TJC15  
DF13 D4081 D4082 D6301 D6302 F1001-T11 SIN-T11 774-2P 774-3P  
774-5P 2060-401 2060-402 2060-403 773-102 773-104 773-106 773-108  
778 294 TU-JTK型叉型预绝缘端头 (SV) TU叉型裸端头 (SNB)  
TO-JTK型圆形预绝缘端头 (RV) 公预绝缘接头 (MDD) 母预绝缘接头 (FDD)  
TG-JT管型预绝缘端头 电缆防水接头 接线端子 软护套 IDC CONNECTOR AUTO  
CONNECTOR DJ7021-1.5-11 DJ7021-1.5-21 DT04  
DT06 UY/K1 UY2/K2 UR/K3 UR2 UB/K4 UB2A UG/K5 U1R/K8 U1B K9  
HJKT10 UDW2 314



Unless otherwise agreed in writing, this document is issued by the Company subject to its General Conditions of Service printed overleaf, available on request or accessible at <http://www.sgs.com/en/Terms-and-Conditions.aspx> and, for electronic format documents, subject to Terms and Conditions for Electronic Documents at <http://www.sgs.com/en/Terms-and-Conditions/Terms-e-Documents.aspx>. Attention is drawn to the limitation of liability, indemnification and jurisdiction issues defined therein. Any holder of this document is advised that information contained hereon reflects the Company's findings at the time of its intervention only and within the limits of Client's instructions, if any. The Company's sole responsibility is to its Client and this document does not exonerate parties to a transaction from exercising all their rights and obligations under the transaction documents. This document cannot be reproduced except in full, without prior written approval of the Company. Any unauthorized alteration, forgery or falsification of the content or appearance of this document is unlawful and offenders may be prosecuted to the fullest extent of the law. Unless otherwise stated the results shown in this test report refer only to the sample(s) tested.

Attention: To check the authenticity of testing /inspection report & certificate, please contact us at telephone: (86-755) 8307 1443, or email: [CN.Doccheck@sgs.com](mailto:CN.Doccheck@sgs.com)

SGS-1602 Standards Technical Services Co., Ltd  
Ningbo Branch

14/F West of Building 4, Lingyin Industry Park, No.1177 Lingyin Road, Ningbo National Hi-Tech Zone, Ningbo, Zhejiang, China 315040 T E&E (86-574)89070249 T ML (86-574)89070242 www.sgsgroup.com.cn  
中国·浙江·宁波市国家高新区凌云路1177号凌云产业园4号楼西1-5层 邮编: 315040 T HL (86-574)89070271 T TY (86-574)89070211 e [sgs.china@sgs.com](mailto:sgs.china@sgs.com)

附件

RoHS 测试流程图

1) 样品按照下述流程被完全消解 (六价铬测试除外)

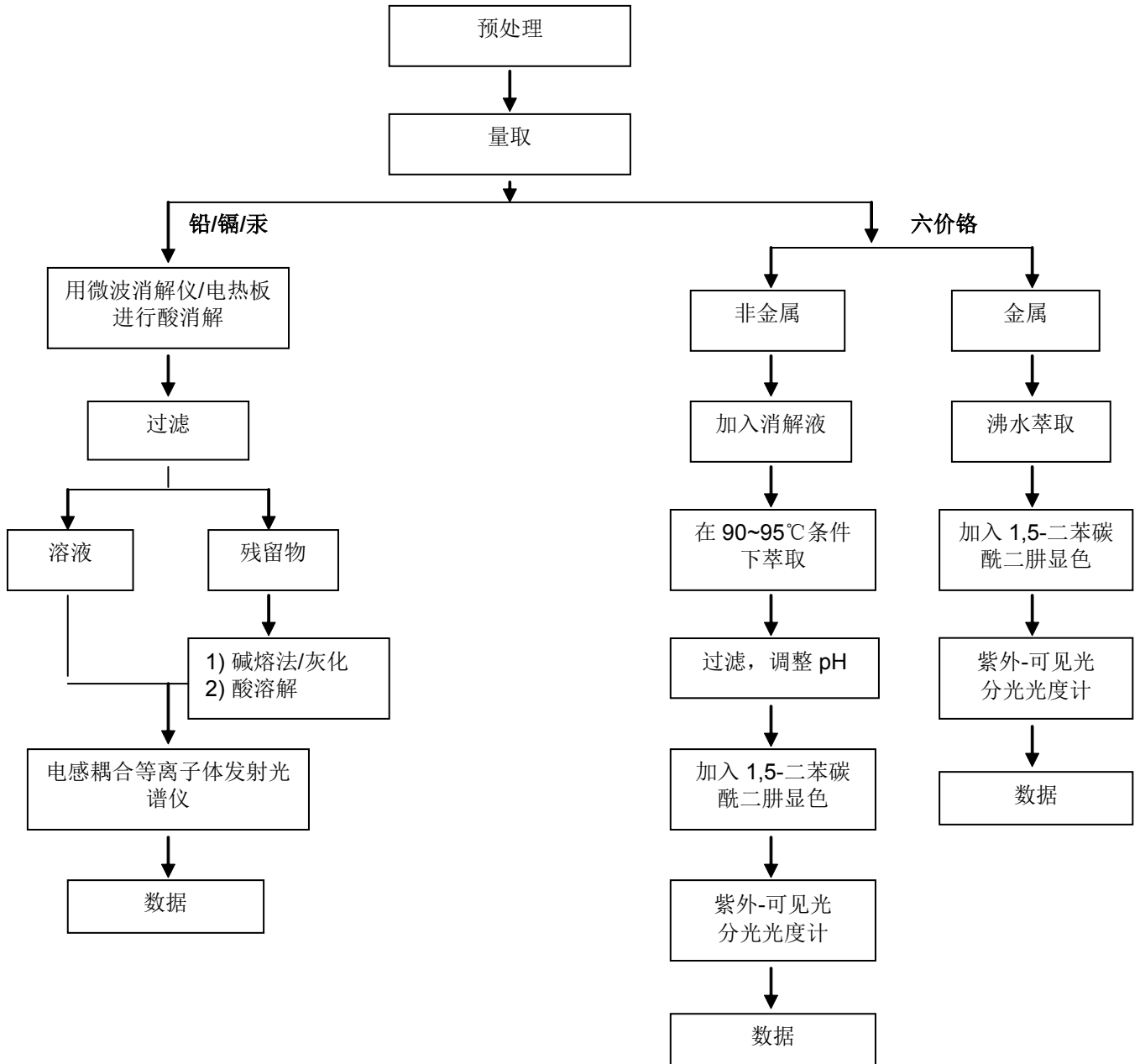

Unless otherwise agreed in writing, this document is issued by the Company subject to its General Conditions of Service printed overleaf, available on request or accessible at <http://www.sgs.com/en/Terms-and-Conditions.aspx> and, for electronic format documents, subject to Terms and Conditions for Electronic Documents at <http://www.sgs.com/en/Terms-and-Conditions/Terms-e-Documents.aspx>. Attention is drawn to the limitation of liability, indemnification and jurisdiction issues defined therein. Any holder of this document is advised that information contained hereon reflects the Company's findings at the time of its intervention only and within the limits of Client's instructions, if any. The Company's sole responsibility is to its Client and this document does not exonerate parties to a transaction from exercising all their rights and obligations under the transaction documents. This document cannot be reproduced except in full, without prior written approval of the Company. Any unauthorized alteration, forgery or falsification of the content or appearance of this document is unlawful and offenders may be prosecuted to the fullest extent of the law. Unless otherwise stated the results shown in this test report refer only to the sample(s) tested.

Attention: To check the authenticity of testing /inspection report & certificate, please contact us at telephone: (86-755) 8307 1443, or email: [CN.Doccheck@sgs.com](mailto:CN.Doccheck@sgs.com)

14/F West of Building 4, Lingyin Industry Park, No.1177 Lingyin Road, Ningbo National Hi-Tech Zone, Ningbo, Zhejiang, China 315040 1 E&E (86-574)89070249 1 ML (86-574)89070242 www.sgs.com.cn  
中国·浙江·宁波市国家高新区凌云路1177号凌云产业园4号楼西1-5层 邮编: 315040 1 HL (86-574)89070271 1 TY (86-574)89070211 e [sgs.china@sgs.com](mailto:sgs.china@sgs.com)

样品照片:

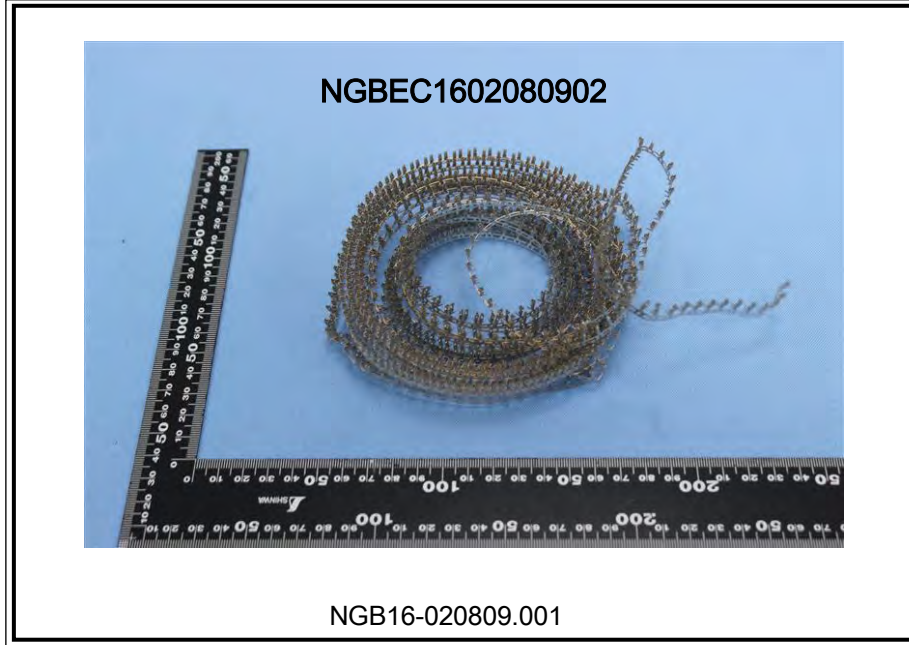

此照片仅限于随SGS正本报告使用

\*\*\* 报告完 \*\*\*



Unless otherwise agreed in writing, this document is issued by the Company subject to its General Conditions of Service printed overleaf, available on request or accessible at <http://www.sgs.com/en/Terms-and-Conditions.aspx> and, for electronic format documents, subject to Terms and Conditions for Electronic Documents at <http://www.sgs.com/en/Terms-and-Conditions/Terms-e-Documents.aspx>. Attention is drawn to the limitation of liability, indemnification and jurisdiction issues defined therein. Any holder of this document is advised that information contained hereon reflects the Company's findings at the time of its intervention only and within the limits of Client's instructions, if any. The Company's sole responsibility is to its Client and this document does not exonerate parties to a transaction from exercising all their rights and obligations under the transaction documents. This document cannot be reproduced except in full, without prior written approval of the Company. Any unauthorized alteration, forgery or falsification of the content or appearance of this document is unlawful and offenders may be prosecuted to the fullest extent of the law. Unless otherwise stated the results shown in this test report refer only to the sample(s) tested.

Attention: To check the authenticity of testing / inspection report & certificate, please contact us at telephone: (86-755) 8307 1443, or email: [CN.Doccheck@sgs.com](mailto:CN.Doccheck@sgs.com)

SGS Standards Technical Services Co., Ltd  
Ningbo Branch

14/F West of Building 4, Lingyin Industry Park, No.1177 Lingyin Road, Ningbo National Hi-Tech Zone, Ningbo, Zhejiang, China 315040 T E&E (86-574)89070249 T ML (86-574)89070242 www.sgsgroup.com.cn  
中国·浙江·宁波市国家高新区凌云路1177号凌云产业园4号楼西1-5层 邮编: 315040 T HL (86-574)89070271 T TY (86-574)89070211 e [sgs.china@sgs.com](mailto:sgs.china@sgs.com)

# 测试报告 (SVHC)

No. NGBEC1602081002

日期: 2016年05月24日 第1页,共9页

浙江联和电子有限公司  
浙江省乐清市石帆镇后屿村

以下测试之样品是由申请者所提供及确认: 端子

SGS工作编号: NP16-001905 - NB

主要成分: 铜, 锡

型号: XH

客户参考信息: 见附件

样品接收日期: 2016年05月16日

测试周期: 2016年05月16日 - 2016年05月20日

测试要求: 根据客户要求,

(i) 基于欧洲化学品管理署截止2015年12月17日公布的供授权审议的高关注物质候选清单(根据欧盟第1907/2006号REACH法规), 对55种无机高关注物质(SVHC)进行筛分测试。

测试结果: 请参见下一页

总结:

|   |    |
|---|----|
| 根据具体的测试范围和分析技术, 委托样品中测试的高关注物质浓度都 $\leq$ 0.1%。 | 通过 |
|---|----|

通标标准技术服务有限公司宁波分公司  
授权签名



Iris Xiao 肖玲艳  
批准签署人

本报告是编号为NGBEC1602081001报告的中文版本



Unless otherwise agreed in writing, this document is issued by the Company subject to its General Conditions of Service printed overleaf, available on request or accessible at <http://www.sgs.com/en/Terms-and-Conditions.aspx> and, for electronic format documents, subject to Terms and Conditions for Electronic Documents at <http://www.sgs.com/en/Terms-and-Conditions/Terms-e-Documents.aspx>. Attention is drawn to the limitation of liability, indemnification and jurisdiction issues defined therein. Any holder of this document is advised that information contained hereon reflects the Company's findings at the time of its intervention only and within the limits of Client's instructions, if any. The Company's sole responsibility is to its Client and this document does not exonerate parties to a transaction from exercising all their rights and obligations under the transaction documents. This document cannot be reproduced except in full, without prior written approval of the Company. Any unauthorized alteration, forgery or falsification of the content or appearance of this document is unlawful and offenders may be prosecuted to the fullest extent of the law. Unless otherwise stated the results shown in this test report refer only to the sample(s) tested.

Attention: To check the authenticity of testing / inspection report & certificate, please contact us at telephone: (86-755) 8307 1443, or email: [CN.Doccheck@sgs.com](mailto:CN.Doccheck@sgs.com)

SGS-160208 Standards Technical Services Co., Ltd. 14/F West of Building 4, Lingyin Industry Park, No.1177 Lingyin Road, Ningbo National Hi-Tech Zone, Ningbo, Zhejiang, China 315040 T E&E (86-574)89070249 T ML (86-574)89070242 www.sgsgroup.com.cn  
中国·浙江·宁波市国家高新区凌云路1177号凌云产业园4号楼西1-5层 邮编: 315040 T HL (86-574)89070271 T TY (86-574)89070211 e [sgs.china@sgs.com](mailto:sgs.china@sgs.com)

## 测试报告 (SVHC)

No. NGBEC1602081002

日期: 2016年05月24日 第2页,共9页

备注:

- (1) 本报告所涉及的关于特定高关注物质的化学分析是根据欧洲化学品管理署发布的下列文件, 利用现有的分析技术完成的。

<http://echa.europa.eu/web/guest/candidate-list-table>

这些文件清单由欧洲化学品管理署评估, 将来可能会有变化。

- (2) 关于物品:

根据欧盟第1907/2006 (EC) 号法规, 如果满足以下两个条件, 如果物质符合第57条中的标准并根据第59条第一款被确定, 物品的任何欧洲制造商或进口商应根据第7条第4款向欧盟化学品管理署进行通报: (a) 候选清单中的物质在物品中的总含量超过1吨/年/生产商或进口商; (b) 候选清单中的物质在物品中的总含量以质量分数计超过0.1% 的浓度。

欧盟第1907/2006 (EC) 号法规第33条规定, 含有满足第57条中的标准并根据第59条第一款被确定且质量分数大于0.1%的物质的物品的所有供应商应向物品接受者提供其可获取的充足信息, 以使物品使用安全, 这些信息至少包括含有的候选清单中物质的名称。

SGS采用ECHA对物品中SVHC的解释, 除非另有说明。详细的解释请见下列网址:

[http://webstage.contribute.sgs.net/corpreach/documents/SGS-CTS\\_SVHC-paper-EN-11.pdf](http://webstage.contribute.sgs.net/corpreach/documents/SGS-CTS_SVHC-paper-EN-11.pdf)

- (3) 关于材料:

报告中的测试结果是基于测试样品。如样品是均一材质, 当其构成成品时, 此结果不能代表成品中的SVHC浓度。如样品为均一材质等比例合测, 这些材质也可能来自不同的物品。

如果样品是一种物质或混合物, 并且直接出口到欧盟, 客户有责任遵守欧盟第1907/2006号REACH法规第31条供应链信息传递的义务和附件十四中的授权高关注物质授权的责任。

- (4) 关于物质和配制品:

如果样品中高关注物质的浓度超过0.1% (w/w) 和/或欧盟第1272/2008号CLP法规和欧盟委员会条例第790/2009号中设定的特殊浓度限值, 建议客户根据欧盟第1907/2006号REACH法规对有关高关注物质准备安全数据表(SDS)以符合供应链传递信息的义务, 如:

- 根据欧盟第1272/2008号CLP法规被列为有害物质。

- 根据危险混合物指令1999/45/EC或欧盟第1272/2008号CLP法规被列为危险混合物, 而其浓度大于或等于危险混合物指令1999/45/EC第3条(3)中规定的限制数值或欧盟第1272/2008号CLP法规附件六第3部分列出的较低值;或

- 根据危险混合物指令1999/45/EC并未列为危险混合物, 但包含:

(a) 对人类健康或环境有害的物质, 而在固体或液体混合物 (即非气体混合物) 中其浓度 $\geq 1\%$  (w/w) 或在气体混合物中占体积 $\geq 0.2\%$ , 或

(b) PBT或vPvB物质, 在固体或液体混合物 (即非气体混合物) 中浓度 $\geq 0.1\%$  (w/w), 或

(c) 授权审议的高关注物质候选清单上的物质 (除上述以外的原因) 在非气体混合物中的浓度 $\geq 0.1\%$  (w/w), 或



Unless otherwise agreed in writing, this document is issued by the Company subject to its General Conditions of Service printed overleaf, available on request or accessible at <http://www.sgs.com/en/Terms-and-Conditions.aspx> and, for electronic format documents, subject to Terms and Conditions for Electronic Documents at <http://www.sgs.com/en/Terms-and-Conditions/Terms-e-Documents.aspx>. Attention is drawn to the limitation of liability, indemnification and jurisdiction issues defined therein. Any holder of this document is advised that information contained hereon reflects the Company's findings at the time of its intervention only and within the limits of Client's instructions, if any. The Company's sole responsibility is to its Client and this document does not exonerate parties to a transaction from exercising all their rights and obligations under the transaction documents. This document cannot be reproduced except in full, without prior written approval of the Company. Any unauthorized alteration, forgery or falsification of the content or appearance of this document is unlawful and offenders may be prosecuted to the fullest extent of the law. Unless otherwise stated the results shown in this test report refer only to the sample(s) tested.

Attention: To check the authenticity of testing /inspection report & certificate, please contact us at telephone: (86-755) 8307 1443, or email: [CN.Doccheck@sgs.com](mailto:CN.Doccheck@sgs.com)

SGS-CTC Standards Technical Services Co., Ltd  
Ningbo Branch

14/F West of Building 4, Lingyin Industry Park, No.1177 Lingyin Road, Ningbo National Hi-Tech Zone, Ningbo, Zhejiang, China 315040 TEL: (86-574)89070249 TML: (86-574)89070242 www.sgs.com.cn  
中国·浙江·宁波市国家高新区凌云路1177号凌云产业园4号楼西1-5层 邮编: 315040 IHL: (86-574)89070271 ITY: (86-574)89070211 e: [sgs.china@sgs.com](mailto:sgs.china@sgs.com)

**测试报告  
(SVHC)**

No. NGBEC1602081002

日期: 2016年05月24日 第3页,共9页

(d) 设有欧洲范围内工作场所接触限值的物质。

(5) 如果样品中SVHC的测试结果超过报告限, 建议客户进一步定量分析检测含有SVHC的组分并且得到SVHC物质的准确浓度。

**测试样品:**

**测试样品描述:**

| 样品编号 | SGS样品ID          | 描述   | 测试SVHC数目 |
|------|------------------|------|----------|
| SN1  | NGB16-020810.001 | 银色金属 | 55       |

**测试方法:**

SGS内部方法-NBCHEM-TOP-138, 采用 ICP-OES和UV-VIS分析.



Unless otherwise agreed in writing, this document is issued by the Company subject to its General Conditions of Service printed overleaf, available on request or accessible at <http://www.sgs.com/en/Terms-and-Conditions.aspx> and, for electronic format documents, subject to Terms and Conditions for Electronic Documents at <http://www.sgs.com/en/Terms-and-Conditions/Terms-e-Documents.aspx>. Attention is drawn to the limitation of liability, indemnification and jurisdiction issues defined therein. Any holder of this document is advised that information contained hereon reflects the Company's findings at the time of its intervention only and within the limits of Client's instructions, if any. The Company's sole responsibility is to its Client and this document does not exonerate parties to a transaction from exercising all their rights and obligations under the transaction documents. This document cannot be reproduced except in full, without prior written approval of the Company. Any unauthorized alteration, forgery or falsification of the content or appearance of this document is unlawful and offenders may be prosecuted to the fullest extent of the law. Unless otherwise stated the results shown in this test report refer only to the sample(s) tested.

Attention: To check the authenticity of testing /inspection report & certificate, please contact us at telephone: (86-755) 8307 1443, or email: [CN.Doccheck@sgs.com](mailto:CN.Doccheck@sgs.com)

SGS-160208 Standards Technical Services Co., Ltd 14/F West of Building 4, Lingyin Industry Park, No.1177 Lingyin Road, Ningbo National Hi-Tech Zone, Ningbo, Zhejiang, China 315040 T E&E (86-574)89070249 T ML (86-574)89070242 www.sgs.com.cn  
 中国·浙江·宁波市国家高新区凌云路1177号凌云产业园4号楼西1-5层 邮编: 315040 T HL (86-574)89070271 T TY (86-574)89070211 e sgs.china@sgs.com

# 测试报告 (SVHC)

No. NGBEC1602081002

日期: 2016年05月24日 第4页,共9页

## 测试结果: (SVHC候选清单中的高关注物质)

| 批次 | 物质名称            | CAS No. | 001<br>浓度 (%) | RL (%) |
|----|-----------------|---------|---------------|--------|
| -  | 所有测试的候选清单中的SVHC | -       | ND            | -      |

### 注释:

- (1) 上表仅显示检出的SVHC, 低于RL的SVHC没有列出。所有测试的SVHC请参见附录
- (2) RL = 报告极限值, 所有RL是基于均一材质的测试。  
ND = 未检出 (< RL), ND针对SVHC物质。
- (3) \* 测试结果是由选定的元素或标记物的结果并基于最坏的情况计算得出。详细信息请参见SGS REACH网站: [www.reach.sgs.com/substance-of-very-high-concern-analysis-information-page.htm](http://www.reach.sgs.com/substance-of-very-high-concern-analysis-information-page.htm)  
硼化合物的结果由ICP-OES测试的总硼(液体, 粉末, 膏体类样品)和水提取(其他样品)的硼元素结果换算得出。  
RL = 0.005% 是针对元素(例如钴、砷、铅、铬(VI)、铝、锆、硼、锆、锌、镉、钛、钡和镉), 除了钨的RL= 0.0005%, 硼的RL= 0.0025%(仅对四氟硼酸铅)。



Unless otherwise agreed in writing, this document is issued by the Company subject to its General Conditions of Service printed overleaf, available on request or accessible at <http://www.sgs.com/en/Terms-and-Conditions.aspx> and, for electronic format documents, subject to Terms and Conditions for Electronic Documents at <http://www.sgs.com/en/Terms-and-Conditions/Terms-e-Documents.aspx>. Attention is drawn to the limitation of liability, indemnification and jurisdiction issues defined therein. Any holder of this document is advised that information contained hereon reflects the Company's findings at the time of its intervention only and within the limits of Client's instructions, if any. The Company's sole responsibility is to its Client and this document does not exonerate parties to a transaction from exercising all their rights and obligations under the transaction documents. This document cannot be reproduced except in full, without prior written approval of the Company. Any unauthorized alteration, forgery or falsification of the content or appearance of this document is unlawful and offenders may be prosecuted to the fullest extent of the law. Unless otherwise stated the results shown in this test report refer only to the sample(s) tested.

Attention: To check the authenticity of testing / inspection report & certificate, please contact us at telephone: (86-755) 8307 1443, or email: [CN.Doccheck@sgs.com](mailto:CN.Doccheck@sgs.com)

14/F West of Building 4, Lingyin Industry Park, No.1177 Lingyin Road, Ningbo National Hi-Tech Zone, Ningbo, Zhejiang, China 315040 T E&E (86-574)89070249 T ML (86-574)89070242 www.sgsgroup.com.cn  
中国·浙江·宁波市国家高新区凌云路1177号凌云产业园4号楼西1-5层 邮编: 315040 T HL (86-574)89070271 T TY (86-574)89070211 e sgs.china@sgs.com

测试报告  
(SVHC)

No. NGBEC1602081002

日期: 2016年05月24日 第5页,共9页

附录

所有测试的SVHC:

| 批次  | 序号 | 物质名称                      | CAS No.                                | RL (%) | 样品ID |
|-----|----|---------------------------|--|--------|------|
| I   | 1  | 二氯化钴*                     | 7646-79-9                              | 0.005  | 001  |
| I   | 2  | 五氧化二砷*                    | 1303-28-2                              | 0.005  | 001  |
| I   | 3  | 三氧化二砷*                    | 1327-53-3                              | 0.005  | 001  |
| I   | 4  | 砷酸氢铅*                     | 7784-40-9                              | 0.005  | 001  |
| I   | 5  | 重铬酸钠*                     | 7789-12-0,<br>10588-01-9               | 0.005  | 001  |
| II  | 6  | 铬酸铅*                      | 7758-97-6                              | 0.005  | 001  |
| II  | 7  | 钼铬红(C.I.颜料红104)*          | 12656-85-8                             | 0.005  | 001  |
| II  | 8  | 铅铬黄(C.I.颜料黄34)*           | 1344-37-2                              | 0.005  | 001  |
| III | 9  | 重铬酸铵*                     | 7789-09-5                              | 0.005  | 001  |
| III | 10 | 硼酸*                       | 10043-35-3,<br>11113-50-1              | 0.005  | 001  |
| III | 11 | 无水四硼酸钠*                   | 1303-96-4,<br>1330-43-4,<br>12179-04-3 | 0.005  | 001  |
| III | 12 | 铬酸钾*                      | 7789-00-6                              | 0.005  | 001  |
| III | 13 | 重铬酸钾*                     | 7778-50-9                              | 0.005  | 001  |
| III | 14 | 铬酸钠*                      | 7775-11-3                              | 0.005  | 001  |
| III | 15 | 水合硼酸钠*                    | 12267-73-1                             | 0.005  | 001  |
| IV  | 16 | 铬酸,<br>铬酸及重铬酸低聚物,<br>重铬酸* | 7738-94-5<br>-<br>13530-68-2           | 0.005  | 001  |
| IV  | 17 | 三氧化铬*                     | 1333-82-0                              | 0.005  | 001  |
| IV  | 18 | 碳酸钴*                      | 513-79-1                               | 0.005  | 001  |
| IV  | 19 | 硝酸钴*                      | 10141-05-6                             | 0.005  | 001  |



Unless otherwise agreed in writing, this document is issued by the Company subject to its General Conditions of Service printed overleaf, available on request or accessible at <http://www.sgs.com/en/Terms-and-Conditions.aspx> and, for electronic format documents, subject to Terms and Conditions for Electronic Documents at <http://www.sgs.com/en/Terms-and-Conditions/Terms-e-Documents.aspx>. Attention is drawn to the limitation of liability, indemnification and jurisdiction issues defined therein. Any holder of this document is advised that information contained hereon reflects the Company's findings at the time of its intervention only and within the limits of Client's instructions, if any. The Company's sole responsibility is to its Client and this document does not exonerate parties to a transaction from exercising all their rights and obligations under the transaction documents. This document cannot be reproduced except in full, without prior written approval of the Company. Any unauthorized alteration, forgery or falsification of the content or appearance of this document is unlawful and offenders may be prosecuted to the fullest extent of the law. Unless otherwise stated the results shown in this test report refer only to the sample(s) tested.

Attention: To check the authenticity of testing /inspection report & certificate, please contact us at telephone: (86-755) 8307 1443, or email: [CN.Doccheck@sgs.com](mailto:CN.Doccheck@sgs.com)

14/F West of Building 4, Lingyin Industry Park, No.1177 Lingyin Road, Ningbo National Hi-Tech Zone, Ningbo, Zhejiang, China 315040 T E&E (86-574)89070249 T ML (86-574)89070242 www.sgs.com.cn  
中国·浙江·宁波市国家高新区凌云路1177号凌云产业园4号楼西1-5层 邮编: 315040 T HL (86-574)89070271 T TY (86-574)89070211 e [sgs.china@sgs.com](mailto:sgs.china@sgs.com)



# 测试报告 (SVHC)

No. NGBEC1602081002

日期: 2016年05月24日 第6页,共9页

附录

所有测试的SVHC:

| 批次   | 序号 | 物质名称          | CAS No.                     | RL (%) | 样品ID |
|------|----|---------------|-----------------------------|--------|------|
| IV   | 20 | 硫酸钴*          | 10124-43-3                  | 0.005  | 001  |
| V    | 21 | 铬酸锶*          | 7789-06-2                   | 0.005  | 001  |
| VI   | 22 | 硅酸铝耐火陶瓷纤维*    | 650-017-00-8<br>(Index no.) | 0.005  | 001  |
| VI   | 23 | 砷酸*           | 7778-39-4                   | 0.005  | 001  |
| VI   | 24 | 砷酸钙*          | 7778-44-1                   | 0.005  | 001  |
| VI   | 25 | 铬酸铬*          | 24613-89-6                  | 0.005  | 001  |
| VI   | 26 | 叠氮化铅*         | 13424-46-9                  | 0.005  | 001  |
| VI   | 27 | 氢氧化铬酸锌*       | 49663-84-5                  | 0.005  | 001  |
| VI   | 28 | 氢氧化铬酸锌钾*      | 11103-86-9                  | 0.005  | 001  |
| VI   | 29 | 砷酸铅*          | 3687-31-8                   | 0.005  | 001  |
| VI   | 30 | 氧化锆硅酸铝耐火陶瓷纤维* | 650-017-00-8<br>(Index no.) | 0.005  | 001  |
| VII  | 31 | 三氧化二硼*        | 1303-86-2                   | 0.005  | 001  |
| VIII | 32 | 四氟硼酸铅*        | 13814-96-5                  | 0.005  | 001  |
| VIII | 33 | 氨基氰铅盐*        | 20837-86-9                  | 0.005  | 001  |
| VIII | 34 | 硝酸铅*          | 10099-74-8                  | 0.005  | 001  |
| VIII | 35 | 一氧化铅*         | 1317-36-8                   | 0.005  | 001  |
| VIII | 36 | 碱式硫酸铅*        | 12036-76-9                  | 0.005  | 001  |
| VIII | 37 | 四氧化三铅*        | 1314-41-6                   | 0.005  | 001  |
| VIII | 38 | 钛酸铅*          | 12060-00-3                  | 0.005  | 001  |
| VIII | 39 | 钛酸铅铅*         | 12626-81-2                  | 0.005  | 001  |



Unless otherwise agreed in writing, this document is issued by the Company subject to its General Conditions of Service printed overleaf, available on request or accessible at <http://www.sgs.com/en/Terms-and-Conditions.aspx> and, for electronic format documents, subject to Terms and Conditions for Electronic Documents at <http://www.sgs.com/en/Terms-and-Conditions/Terms-e-Documents.aspx>. Attention is drawn to the limitation of liability, indemnification and jurisdiction issues defined therein. Any holder of this document is advised that information contained hereon reflects the Company's findings at the time of its intervention only and within the limits of Client's instructions, if any. The Company's sole responsibility is to its Client and this document does not exonerate parties to a transaction from exercising all their rights and obligations under the transaction documents. This document cannot be reproduced except in full, without prior written approval of the Company. Any unauthorized alteration, forgery or falsification of the content or appearance of this document is unlawful and offenders may be prosecuted to the fullest extent of the law. Unless otherwise stated the results shown in this test report refer only to the sample(s) tested.

Attention: To check the authenticity of testing / inspection report & certificate, please contact us at telephone: (86-755) 8307 1443, or email: [CN.Doccheck@sgs.com](mailto:CN.Doccheck@sgs.com)

SGS-20 Standards Technical Services Co., Ltd  
Ningbo Branch

14/F West of Building 4, Lingyin Industry Park, No.1177 Lingyin Road, Ningbo National Hi-Tech Zone, Ningbo, Zhejiang, China 315040 T E&E (86-574)89070249 T ML (86-574)89070242 www.sgs.com.cn  
中国·浙江·宁波市国家高新区凌云路1177号凌云产业园4号楼西1-5层 邮编: 315040 T HL (86-574)89070271 T TY (86-574)89070211 e [sgs.china@sgs.com](mailto:sgs.china@sgs.com)

测试报告  
(SVHC)

No. NGBEC1602081002

日期: 2016年05月24日 第7页,共9页

附录

所有测试的SVHC:

| 批次   | 序号 | 物质名称     | CAS No.                   | RL (%) | 样品ID |
|------|----|----------|---------------------------|--------|------|
| VIII | 40 | 硫酸四氧化五铅* | 12065-90-6                | 0.005  | 001  |
| VIII | 41 | 铅锑黄*     | 8012-00-8                 | 0.005  | 001  |
| VIII | 42 | 掺杂铅的硅酸钡* | 68784-75-8                | 0.005  | 001  |
| VIII | 43 | 硅酸铅*     | 11120-22-2                | 0.005  | 001  |
| VIII | 44 | 二碱式亚硫酸铅* | 62229-08-7                | 0.005  | 001  |
| VIII | 45 | 硫酸三氧化四铅* | 12202-17-4                | 0.005  | 001  |
| VIII | 46 | 碱式碳酸铅*   | 1319-46-6                 | 0.005  | 001  |
| VIII | 47 | 二碱式亚磷酸铅* | 12141-20-7                | 0.005  | 001  |
| IX   | 48 | 氧化镉*     | 1306-19-0                 | 0.005  | 001  |
| IX   | 49 | 镉*       | 7440-43-9                 | 0.005  | 001  |
| X    | 50 | 硫化镉*     | 1306-23-6                 | 0.005  | 001  |
| XI   | 51 | 氯化镉*     | 10108-64-2                | 0.005  | 001  |
| XI   | 52 | 水合过硼酸钠*  | -                         | 0.005  | 001  |
| XI   | 53 | 过硼酸钠*    | 7632-04-4                 | 0.005  | 001  |
| XII  | 54 | 氟化镉*     | 7790-79-6                 | 0.005  | 001  |
| XII  | 55 | 硫酸镉*     | 10124-36-4,311<br>19-53-6 | 0.005  | 001  |



Unless otherwise agreed in writing, this document is issued by the Company subject to its General Conditions of Service printed overleaf, available on request or accessible at <http://www.sgs.com/en/Terms-and-Conditions.aspx> and, for electronic format documents, subject to Terms and Conditions for Electronic Documents at <http://www.sgs.com/en/Terms-and-Conditions/Terms-e-Documents.aspx>. Attention is drawn to the limitation of liability, indemnification and jurisdiction issues defined therein. Any holder of this document is advised that information contained hereon reflects the Company's findings at the time of its intervention only and within the limits of Client's instructions, if any. The Company's sole responsibility is to its Client and this document does not exonerate parties to a transaction from exercising all their rights and obligations under the transaction documents. This document cannot be reproduced except in full, without prior written approval of the Company. Any unauthorized alteration, forgery or falsification of the content or appearance of this document is unlawful and offenders may be prosecuted to the fullest extent of the law. Unless otherwise stated the results shown in this test report refer only to the sample(s) tested.

Attention: To check the authenticity of testing / inspection report & certificate, please contact us at telephone: (86-755) 8307 1443, or email: [CN.Doccheck@sgs.com](mailto:CN.Doccheck@sgs.com)

SGS-160208 Standards Technical Services Co., Ltd  
Ningbo Branch

14/F West of Building 4, Lingyin Industry Park, No.1177 Lingyin Road, Ningbo National Hi-Tech Zone, Ningbo, Zhejiang, China 315040  
中国·浙江·宁波市国家高新区凌云路1177号凌云产业园4号楼西1-5层

TEL (86-574)89070249 TML (86-574)89070242 www.sgs.com.cn  
TEL (86-574)89070271 TTY (86-574)89070211 e sgs.china@sgs.com

## 测试报告 (SVHC)

No. NGBEC1602081002

日期: 2016年05月24日 第8页,共9页

附件:

1.0 1.25 DF14 GH ZH PH PA PHSD DF11 C1251 51146 FI-S  
PHD YHD200 SMW SMH200 SMH200-H 20039WR 杜邦  
2.0 XH/TJC3 XA HA XHB EH SZN SAN SCN SCND JC15 JC20  
JC25 5264 250 LGC CH2.5 EI/小EP S11 HR 线扣 YH025 35155  
5102 5240 SMH250 SMP250 SMW250 25048HS 25045HP  
SM TJC8/杜邦2.54 TJC8A/杜邦带锁 TJC8B TJC8H 5051/2510 543  
美尚美 CH10 25415 43645 43020 43025 5500  
5600 VH VHRR/YH396 VHR 35156 2139/3.96 90331 5195 5196  
39612 FL 5557 5559 5566 5569 42474 42475 SL RV42 CL014/OTP  
EL YL 小型EL QH NV 50300 50301 8981/大四P 5058/5.08 5197  
5198 5025 L6.2 VL VLP/VLR 3191 5199 TJC2 TJC2A TJC2B STV5  
YHL500 YWL500 TJC4 TJC1 SMF Cy-X201/35108 35150 35151 35224  
35180 35965 1806 110 2.8 42021 42022 42002 6.3 250 35955 SA  
SCS 35189 35196 DF11 MX3.0  
1.58 51005 51006 BH3.5 BH4.0 EL 63080 187 250 51004 TJC15  
DF13 D4081 D4082 D6301 D6302 F1001-T11 SIN-T11 774-2P 774-3P  
774-5P 2060-401 2060-402 2060-403 773-102 773-104 773-106 773-108  
778 294 TU-JTK型叉型预绝缘端头 (SV) TU叉型裸端头 (SNB)  
TO-JTK型圆形预绝缘端头 (RV) 公预绝缘接头 (MDD) 母预绝缘接头 (FDD)  
TG-JT管型预绝缘端头 电缆防水接头 接线端子 软护套 IDC CONNECTOR AUTO  
CONNECTOR DJ7021-1.5-11 DJ7021-1.5-21 DT04  
DT06 UY/K1 UY2/K2 UR/K3 UR2 UB/K4 UB2A UG/K5 U1R/K8 U1B K9  
HJKT10 UDW2 314



Unless otherwise agreed in writing, this document is issued by the Company subject to its General Conditions of Service printed overleaf, available on request or accessible at <http://www.sgs.com/en/Terms-and-Conditions.aspx> and, for electronic format documents, subject to Terms and Conditions for Electronic Documents at <http://www.sgs.com/en/Terms-and-Conditions/Terms-e-Documents.aspx>. Attention is drawn to the limitation of liability, indemnification and jurisdiction issues defined therein. Any holder of this document is advised that information contained hereon reflects the Company's findings at the time of its intervention only and within the limits of Client's instructions, if any. The Company's sole responsibility is to its Client and this document does not exonerate parties to a transaction from exercising all their rights and obligations under the transaction documents. This document cannot be reproduced except in full, without prior written approval of the Company. Any unauthorized alteration, forgery or falsification of the content or appearance of this document is unlawful and offenders may be prosecuted to the fullest extent of the law. Unless otherwise stated the results shown in this test report refer only to the sample(s) tested.

Attention: To check the authenticity of testing /inspection report & certificate, please contact us at telephone: (86-755) 8307 1443, or email: [CN.Doccheck@sgs.com](mailto:CN.Doccheck@sgs.com)

SGS Standards Technical Services Co., Ltd. 14/F West of Building 4, Lingyin Industry Park, No.1177 Lingyin Road, Ningbo National Hi-Tech Zone, Ningbo, Zhejiang, China 315040 T E&E (86-574)89070249 T ML (86-574)89070242 www.sgsgroup.com.cn  
中国·浙江·宁波市国家高新区凌云路1177号凌云产业园4号楼西1-5层 邮编: 315040 T HL (86-574)89070271 T TY (86-574)89070211 e sgs.china@sgs.com

## SVHC 测试流程图

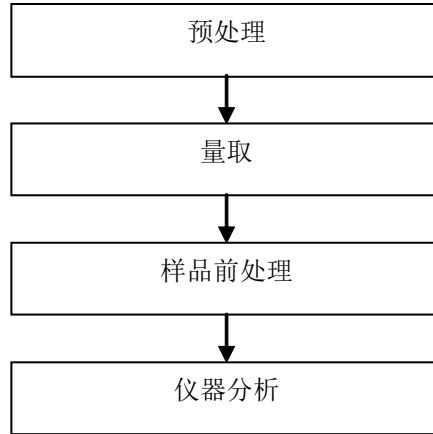

样品照片:



此照片仅限于随SGS正本报告使用

\*\*\* 报告完 \*\*\*



Unless otherwise agreed in writing, this document is issued by the Company subject to its General Conditions of Service printed overleaf, available on request or accessible at <http://www.sgs.com/en/Terms-and-Conditions.aspx> and, for electronic format documents, subject to Terms and Conditions for Electronic Documents at <http://www.sgs.com/en/Terms-and-Conditions/Terms-e-Documents.aspx>. Attention is drawn to the limitation of liability, indemnification and jurisdiction issues defined therein. Any holder of this document is advised that information contained hereon reflects the Company's findings at the time of its intervention only and within the limits of Client's instructions, if any. The Company's sole responsibility is to its Client and this document does not exonerate parties to a transaction from exercising all their rights and obligations under the transaction documents. This document cannot be reproduced except in full, without prior written approval of the Company. Any unauthorized alteration, forgery or falsification of the content or appearance of this document is unlawful and offenders may be prosecuted to the fullest extent of the law. Unless otherwise stated the results shown in this test report refer only to the sample(s) tested.

Attention: To check the authenticity of testing / inspection report & certificate, please contact us at telephone: (86-755) 8307 1443, or email: [CN.Doccheck@sgs.com](mailto:CN.Doccheck@sgs.com)

SGS-160208 Standards Technical Services Co., Ltd  
Ningbo Branch 宁波标准技术服务有限公司

14/F West of Building 4, Lingyin Industry Park, No.1177 Lingyin Road, Ningbo National Hi-Tech Zone, Ningbo, Zhejiang, China 315040 1 E&E (86-574)89070249 1 ML (86-574)89070242 www.sgsgroup.com.cn  
中国·浙江·宁波市国家高新区凌云路1177号凌云产业园4号楼西1-5层 邮编: 315040 1 HL (86-574)89070271 1 TY (86-574)89070211 e sgs.china@sgs.com

## 物質安全資料表(MSDS)

### 一、物品與廠商資料

|                |
|----------------|
| 物品名稱： 尼龙 66 切片 |
| 物品編號： /        |
|                |
| 傳真電話：          |

### 二、成分辨識資料

純物質：

|   |
|---|
| 中英文名稱： 尼龙 66(polyhexamethylenedipamide) |
| 同義名稱： nylon66                           |
| 化學文摘社登記號碼(CAS No.): 32131-17-2          |
| 危害物質成分(成分百分比)： /                        |

| 物質成分分析                            |                |           |
|-----------------------------------|----------------|-----------|
| 物質成分之中英文名稱                        | 濃度或濃度範圍(成分百分比) | 危害物質分類及圖式 |
| 尼龙<br>66polyhexamethylenedipamide | 99%            |           |
| 其他杂质                              | 1%             |           |

### 三、危害辨識資料

|  |              |
|--|--------------|
| <b>最<br/>重<br/>要<br/>危<br/>害<br/>效<br/>應</b> | 健康危害效應： 無    |
|  | 環境影響： 無      |
|  | 物理性及化學性危害： 無 |
|  | 特殊危害： 無      |
| 遇燃或遇熱分解會產生有毒氣體，如一氧化碳，二氧化碳，氮氧化物。              |              |

### 四、急救措施

|  |
|--|
| 不同暴露途徑之急救方法：   |
| <ul style="list-style-type: none"> <li>· 萬一吸入燃燒物：將該人員移到露天地並請醫生；</li> <li>· 萬一熔融物引起嚴重灼傷：儘可能速度在冷水中將物料冷卻，並立即進行醫療檢查。</li> <li>· 萬一聚合物粉末或氣體觸及眼睛，應掀起眼睛，徹底用水沖洗，並去醫療檢查。</li> </ul> |
| 對急救人員之防護： 產品遠離火源，萬一燃燒時避免吸入煙霧。  |
| 對醫師之提示： 無  |

### 五、滅火措施

|                         |
|-------------------------|
| 適用滅火劑： 水霧，泡沫，二氧化碳和化學干粉。 |
|-------------------------|

|                       |
|-----------------------|
| 滅火時可能遭遇之特殊危害： 避免吸入烟霧。 |
| 特殊滅火程式： 無             |
| 消防人員之特殊防護設備： 無        |

## 七、安全處置與儲存方法

|  |
|--|
| 處置： 無  |
| 儲存： 1 將產品密封於容器中存於低溫乾燥處。<br>2 確保在加工階段良好通風。<br>3 該聚合物對環境無有害影響。 |

# 物质安全资料表

## 一、物品与厂商资料

|                                       |
|---------------------------------------|
| 物品名称：液晶高分子聚合物（LCP）                    |
| 物品编号：E130I                            |
| 制造商或供货商名称：深圳市华联威电子科技有限公司              |
| 制造商或供货商地址：中国 广东 深圳市龙岗区布吉镇坂田南坑工业区南坑工业区 |
| 咨询者姓名：黄经理 联络电话：86 0755 84160519       |

## 二、成分辨识资料

中英文名称： LCP 液晶高分子聚合物

| 化学品名称  | 含量  |
|--------|-----|
| LCP 树脂 | 67% |
| 玻璃纤维   | 30% |
| 助剂     | 3%  |

## 三、危害辨识数据

|         |  |
|---------|--|
| 最重要危害效应 | 进入人体之途径： <input type="checkbox"/> 吞食 <input type="checkbox"/> 皮肤接触 <input type="checkbox"/> 吸入<br>健康危害效应：急性：无<br>慢性：无<br>健康危害效应<br><ul style="list-style-type: none"><li>眼睛：没有有效数据。</li><li>皮肤：熔融时接触会烫伤。</li><li>吸入：料粒不大可能吸入。</li><li>食入：没有显著有害效应。</li></ul> |
|---------|--|

## 四、急救措施

|  |
|--|
| 不同暴露途径之急救方法：<br><br>吸入：若吸入熔融树脂产生的气体较多时，若需立刻送医治疗。 皮肤接触：若接触到熔胶，用清水冲洗，若有不适，立刻送医治疗。 眼睛接触：若眼睛接触到塑胶粉末，用水冲洗十五分钟以上如需要，到医院治疗。<br>食入：催吐，以清水漱口。 |
|--|

## 五、灭火措施

灭火材料:水、泡沫、干粉

灭火时可能遭遇之特殊危害:无。特殊灭火程序:移除可燃物。灭火者访护:消防人员使用供氧式呼吸防护具。

## 六、泄漏处理方法

注意事项:若塑料粒或塑料粉末残留于地面上,立即清扫处理,以防人员滑倒。

清理方法:回收或弃置(依当地环保单位废弃物管理办法,在合法的弃置掩埋)。

## 七、安全处置与储存方法

处置:工作场所有《严禁烟火》标志,不能燃烧。

储存:封包存放在阴凉处所,避免直射阳光及雨淋,储存处严禁烟火。

## 八、暴露预防措施

容许湿度:(TLV)未定 通风设备:

排除粉,烟及气体时使用。个人防护:

眼部:使用安全眼镜或护目镜。呼吸:使用含有中、低有机蒸气滤罐之面具。手部:接触熔胶时使用皮手套。防护衣服设备:1.安全鞋.2.工作区须有紧急冲淋器。

个人卫生:1.工作后速脱掉污染衣物,且须告知洗衣人员污染危害性。2.工作场所严禁吸烟或饮食。3.处理本物质后须及时洗手。4.维持作业场所清洁。

## 九、物理及化学性质

刺激性:分解后之塑料所产生的烟及蒸气会刺激眼睛。

## 十、安定性及反应性

安定性:安定

特殊状况下可能之危害反应:会发生放热的聚合反应。避免接触热、光、空气、治疗剂,密闭容器可能会爆裂。

应避免之状况:避免热、火种及着火物质。若曝露于热源,容器可能破裂或爆破。

应避免之物质:金属盐、可燃物质、金属、氧化剂、卤素、金属氧化物。

危害分解物:碳氧化合物之有毒或有害之气体。



## 十一、毒性资料

### 急毒性:

- 吸入：用火燃烧产生气体会引起呼吸道之刺激与咳嗽。曝露在高浓度的气体时会导致反胃、刺痛、与口腔和喉咙干燥，困倦、头痛、眩晕、失去知觉、呼吸麻痹与死亡，另外也会窒息。
- 食入：不大可能食入，但会造成口腔与喉咙的创伤。
- 皮肤：会引起瘙痒。
- 眼睛：燃烧产生的气体会引起刺激。

局部效应：没有有效数据。

致敏感性：没有有效数据。

### 慢毒性或长期毒性:

- 食入：没有有效数据。
- 吸入：没有有效数据。
- 皮肤：没有有效数据。
- 眼睛：没有有效数据。

## 十二、生态资料

为防止被海洋生物及鸟类取食,严禁丢弃海洋或水域。

## 十三、废弃物处理及处置

1. 参考相关法规处理。
2. 依照仓储条件储存待处理的废弃物。
3. 可采用特定的焚化或卫生掩埋法处理。

## 十四、运送资料

未分类

## 十五、适用法规

标示： 危害警告讯

息： 难燃。 危害防范

措施：

1. 置于阴凉且通风良好处。
2. 远离火源。
3. 配戴护目镜/防毒面具。
4. 使用化学干粉，泡沫及水雾。

使用法规：

劳工安全卫生设备规则 危险物与有害物能通识规则 道路交通安全规则  
事业废弃物储存清除处理方法及措施标准 防护衣服设备：1.安全鞋.2.工  
作区须有紧急冲淋器。

个人卫生：1.工作后速脱掉污染衣物,且须告知洗衣人员污染危害性。2.工作场所  
严 禁吸烟或饮食。3.处理本物质后须及时洗手。4.维持作业场所清洁。

# MSDS

## 1. 物品成分与厂商资料

|  |                  |
|--|------------------|
|  | 物品编号: QSN6.5-0.1 |
|  | 物品名称: 磷铜端子       |
|  | 纯物质:             |
|  | 有害物质成分 (%) 无     |

## 2. 成份辨识资料

| 成份名称   | 化学文摘社登记号码(CAS No.) | 浓度范围 (成分百分比 Percentage (%)) |
|--------|--------------------|-----------------------------|
| 铜(Cu)  | 7440-50-8          | 余量                          |
| 磷(P)   | 7723-14-0          | 0.0026-0.005%               |
| 锌(Zn)  | 7440-66-6          | 0.03-0.04%                  |
| 镍(Ni)  | 7440-02-0          | 0.054-0.063%                |
| 锑 (Sb) | 7440-36-0          | 0.00015%                    |
| 铅(Pb)  | 7439-92-1          | <0.005%                     |
| 铁(Fe)  | 7439-89-6          | 0.005-0.0059%               |
| 纯镍(Ni) | 7440-02-0          | 0.054-0.063%                |
| 纯锡(Sn) | 7440-31-5          | 6.2 %                       |

## 2. 危害辨认资料

|        |                          |
|--------|--------------------------|
| 严重危害效应 | 健康危害效应: 本产品为固体时不具健康危害及危害 |
|        | 环境影响: 本产品为固体时对环境不具影响     |
|        | 物理性及化学性危害: 固体/无味/多色      |
|        | 特殊危害: 固体时(防火或高温)无特殊危害    |

主要症状: 无

## 3. 急救措施

|      |             |
|------|-------------|
| 急救方法 | 吸入: 无吸入     |
|      | 皮肤接触: 接触无危害 |
|      | 食入: 无食入     |

主要症状及危害效应: 无

## 4. 灭火措施

|                               |
|-------------------------------|
| 通用灭火器: 二氧化碳, 泡沫, 干粉化学灭火器, 水雾等 |
| 灭火时可能遭遇之特殊危害: 会引起火灾           |
| 消防人员之特殊防护装备: 使用从氧式吸防护具        |

## 5. 泄漏处理方法

|                                       |
|---------------------------------------|
| 个人应注意事项: 注意工作台面清洁, 作业时及时清洗手           |
| 环境注意事项: 将泄漏之物料以容器盛装以便回收或废弃            |
| 清理方式: 工作台面每天作业前/后须擦拭干净, 建议可以戴手套或手指套作业 |

## 6. 安全处置与储存方法

|                            |
|----------------------------|
| 处置: 废弃物可送到政府许可的废弃物处理中心进行处理 |
|----------------------------|

|  |                                   |
|--|-----------------------------------|
| 储存：空调仓，23±5℃，湿度 65%以下，仓库里面安装灭火器  |                                   |
| 7. 暴露预防措施  |                                   |
| 个人防护设备   | 呼吸防护：口罩，一般无此要求，可以建议采用             |
|  | 手部防护设备：手套火手指套，一般无此要求，可以建议采用       |
|  | 眼睛防护：安全目镜或眼镜                      |
|  | 皮肤及身体防护：穿工作服，经常勤洗                 |
| 卫生措施：建议使用安全目镜，进食前应洗手及脸部，平时多运动，保持健康体力   |                                   |
| 8. 物料及化学性质   |                                   |
| 物质状态：固体  | 形状：连接器                            |
| 颜色：多色  | 气味：无味                             |
| PH 值：未测定   | 沸点：未测定                            |
| 分解温度：未测定   | 爆炸介限：无                            |
| 自然温度：固体无   | 溶解度：固体无                           |
| 9. 安全性及反应性   |                                   |
| 安全性：正常状态下安全  |                                   |
| 特殊状况下可能之危害反应：无   |                                   |
| 应避免之状况：避免接触火源和太阳光直射  |                                   |
| 应避免之物质：火和酸碱性物质   |                                   |
| 危害分解物：无  |                                   |
| 10. 毒性资料   |                                   |
| 急毒性  | 吸入：无                              |
|  | 皮肤接触：无                            |
|  | 眼睛：无                              |
| 局部效应：无   | 特殊效应：无                            |
| 11. 废弃物处理方法：废弃物可送到政府许可的废弃物处理中心进行处理   |                                   |
| 12. 运送资料   |                                   |
| 联合国编号：无  | 运输规定：并无危险分类                       |
| 运送方法及注意事项：勿重压，轻拿轻放   |                                   |
| 13. 适用法规：1.劳工安全卫生设施规划；2.危害物及有害物通讯规划；3.索尼环境通用规定；4 劳工用业环境空气中有害物容许溶度标准；5 道路交通安全规划 |                                   |
| 14. 其他资料：  |                                   |
| 15.法规资料  |                                   |
| 适用法规   | 1.劳工安全卫生设施规则<br>2.RoHS 法规及有害物通识规则 |
| 16.其它资料  |                                   |
| 参考文献   | 有害化学物质中文资料库，环保局                   |
| 制表单位   | 浙江联和电子有限公司                        |
| 制造商及供应商地址  | 浙江省乐清市石帆镇后屿工业区                    |
| 电话   | 0577-62383699                     |
| 制表者  | 季育文                               |
| 制表日期   | 2012-3-23                         |

## X-ON Electronics

Largest Supplier of Electrical and Electronic Components

*Click to view similar products for [Headers & Wire Housings](#) category:*

*Click to view products by [CAX](#) manufacturer:*

Other Similar products are found below :

[95000-104TRLF](#) [10135584-644402LF](#) [DF62W-EP2022PCA](#) [95000-106TRLF](#) [DF62W-2022SCA](#) [DF62W-EP2022PC](#) [2203348](#) [DF62W-2022SC](#) [1084018](#) [1029039](#) [1084017](#) [802-10-012-10-002000](#) [1112640](#) [1112639](#) [891-007-9SS-BST1T](#) [000-34000](#) [0008550134](#) [0009482033](#) [0009507031](#) [57102-F02-18ULF](#) [57102-S06-03LF](#) [57202-S52-04LF](#) [PCN6-15S-2.5E](#) [0039019024](#) [58102-G61-06LF](#) [582553-1](#) [0009485154](#) [0009508121](#) [0022285053](#) [0050291907](#) [018731A](#) [LY20-4P-DT1-P1E-BR](#) [02.125.8002.8](#) [60101931](#) [60598-1 \(Cut Strip\)](#) [M1625-3R/100](#) [61062-3](#) [61082-181009](#) [CSU011177004](#) [636-1427](#) [638009-1](#) [641938-9](#) [641991-4](#) [644168-1](#) [644827-2](#) [647662-1](#) [65039-019ELF](#) [65692-001LF](#) [65781-018](#) [65781-047](#)