



Continental Device India Pvt. Ltd
An ISO/TS 16949, ISO 9001 and ISO 14001 Certified Company



MOS IC Non-isolated APFC BUCK LED Controller

TCIL6568

The Document is Applied to: TTCIL6568-7 & TTCIL6568-14

1. General Description

The TCIL6568 is a non-isolated BUCK topology constant current control LED controller with Active Power Factor Correction (APFC). For 85Vac-265Vac input voltage, it can achieve high precision LED output current, high power factor, low THD and high system efficiency.

The TCIL6568 works in boundary conduction mode to reduce the MOSFET switching losses. The TCIL6568 integrate 600V MOSFET internally, which simplifies external circuit. The system full wave detection mode makes the high precision of constant current controlling, also the Line Voltage Regulation and Load Regulation.

The multi-protection feature of TCIL6568 significantly improves the system reliability and safety. The TCIL6568 features VCC under voltage lock out, LED open/short-circuit protection, CS resistor open-circuit protection, cycle-by-cycle current limit, and intelligent thermal adjust.

TCIL6568-7 is for 3 to 7 watt driver applications and TCIL6568-14 is for 9-14 watt driver applications.

Features:

- Inductance Current of Boundary-Continuous Mode
- Integrate Active Power Factor Correction, High PF, Low THD
- High Precision of LED output current: $\pm 3\%$
- Superior Line Voltage Regulation and Load Regulation
- Low Start Up Current
- Extremely Low Quiescent Current
- High Precision LED Output current for 100Vac-300Vac Input Voltage
- Output Open/Short Circuit Protection
- CS Resistor Open-circuit protection
- VCC UVLO
- Integrate 600V power MOSFET
- Package: SOP7

2. Function Diagram and Pin Description

2.1. Function Diagram

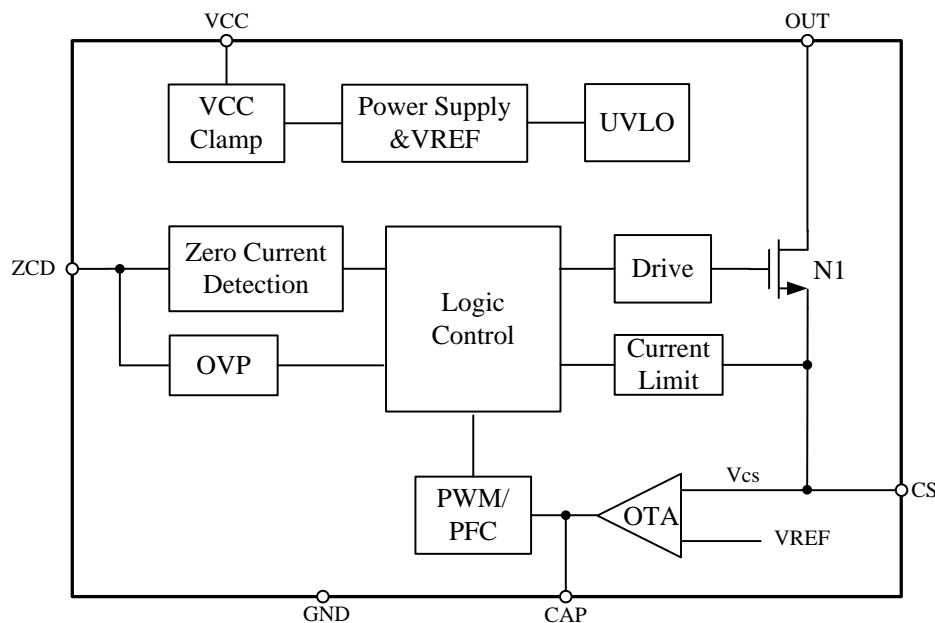

2.2. Function Description

The TCIL6568 is a high-PF non-isolated BUCK topology LED controller with Active Power Factor Correction (APFC) internally. The TCIL6568 works in boundary conduction mode and employs unique control mode to achieve high precision LED output current. Also it achieved superior Line Voltage Regulation and Load Regulation

2.2.1. Start up and UVLO

Initially, the capacitor beside VCC pin is charged through the start up resistor from the AC line. After the VCC voltage climbs up to VCC turn voltage threshold V_{CC_ON} , the control logic start to work. After the output voltage established, the output voltage supply power for VCC through diode to reduce system power dissipation.

When VCC falls below VCC turn off voltage threshold V_{CC_OFF} , the system shut down, and the system enters another start up cycle.

2.2.2. Power-on Soft-start

The TCIL6568 supply soft-start function. The IC works in 10 kHz switch frequency after power on, and the CAP pin voltage is pulled up to 1.5V. After the output pulse established, CAP voltage rises from 1.5V, and the inductor peak current rise gradually along with CAP voltage,

which achieve the soft-start.

Soft-start function can help to restrain clash current to reduce LED stress during start up, which can extend the LED life. On the other hand, soft-start also can restrain clash voltage on MOSFET's drain to increase the system reliability.

2.2.3、 Power Factor Correction

After the system is stable, the voltage V_{CAP} will be constant. The TCIL6568 achieve high PF though ensure MOSFET on time stable. The relation between $V_{in}(t)$, T_{ON} , L and inductor peak current $I_p(t)$ can be calculated as follow:

$$[V_{in}(t) - V_{LED}] \times T_{on} = L \times I_p(t)$$

$V_{in}(t)$ is a sinusoidal half-wave, and the envelope of inductor current peak value $I_p(t)$ follow with the input voltage $V_{in}(t)$, which makes the system achieve high PF.

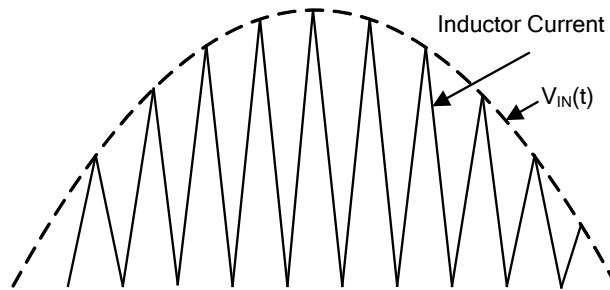

Fig.2 Power Factor Correction Scheme

2.2.4、 Constant Current Control

The TCIL6568 employs unique constant current control method and works in boundary continuous mode, which could control the LED output current accurately.

LED output current can be calculated as:

$$I_O = \frac{V_{REF}}{R_{CS}}$$

V_{REF} -feedback loop reference voltage (typically 0.2V)

R_{CS} -The sensing resistor connected between CS pin and GND

2.2.5、 Zero Current Detect

When power MOSFET is off, the inductor current fall linearly from peak value to zero, also make supply power for LED load and charge the output capacitor through freewheeling diode. When inductor current falls to zero, the inductor voltage will fall to zero quickly. ZCD pin sense the inductor voltage through divider resistor, and when detected voltage falls below V_{ZCD_FALL} , turn on the MOSFET.

2.2.6. Output Over-Voltage Protection

The TCIL6568 detect the output voltage through ZCD pin during demagnetize process. When the voltage of ZCD pin exceeds the OVP threshold, the OVP signal will be triggered and latched, the MOSFET will be turned off and the IC work at quiescent mode, the VCC voltage dropped below the UVLO which will make the IC shut down and the system restarts again. The output OVP setting point can be calculated as:

$$V_{LED_OVP} = \frac{R1 + R2}{R1} \times 1.6V$$

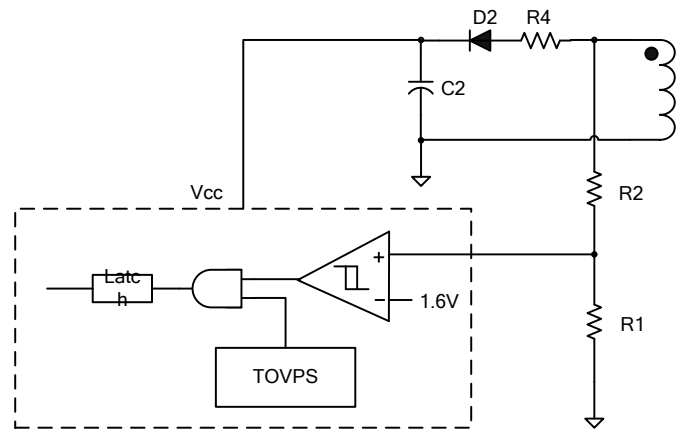

Fig.3 Principle of VCC OVP

To prevent OVP trigger falsely for inductor surge spike, the TCIL6568 designed LEB time to ensure zero current detect sample point fall in the flat range, which is shown in Fig.4.

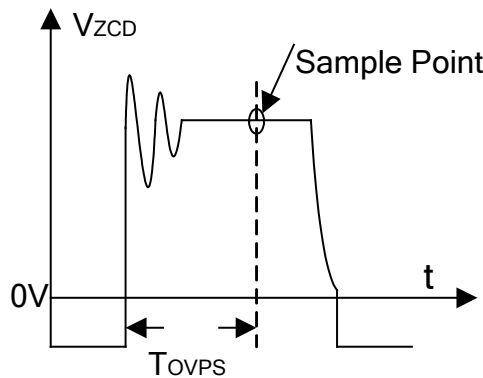

Fig.4 ZCD Pin Voltage and OVP Sample Point

2.2.7. Output Short-Circuit Protection

When the LED is shorted to ground, the output voltage is clamped to zero. The winding can't supply current for Vcc, so Vcc will drop down. Since the Vcc is below VCC off voltage, the system will restart and operate in hiccup mode until the shorted condition is removed.

2.2.8、 Intelligent Thermal Adjust

To prevent from any lethal thermal damage, the TCIL6568 has internal intelligent thermal adjust function. When the inner temperature exceeds the threshold, the TCIL6568 decrease the output current gradually this can control the output power and temperature rising to improve the system reliability. The IC set the over temperature adjust threshold 150°C.

2.3、 Pin Configuration

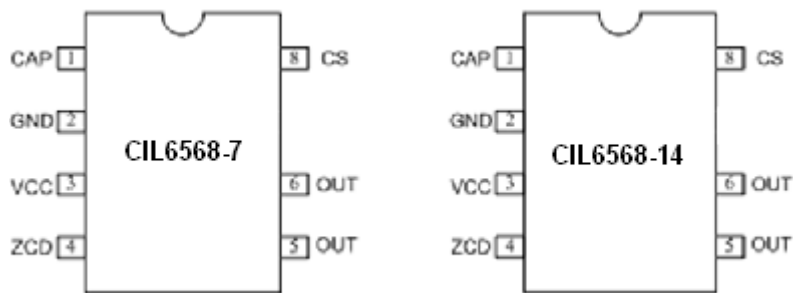

2.4、 Pin Description and Structure Scheme

Pin	Symbol	Function	I/O	Structure Scheme
1	CAP	Internal EA's Output Pin. Connect a Capacitor to Ground	I/O	
2	GND	Ground Pin	P	
3	VCC	Supply Voltage Pin.	P	
4	ZCD	Zero Current Detection Pin	I/O	
5, 6	OUT	The Drain of The Power MOSFET	O	
8	CS	Current Sense Pin. Source of Power MOSFET, and Connect a Resistor to Ground.	I/O	

3、Electrical Characteristics

3. 1、Absolute Maximum Ratings

Unless otherwise specified, $T_{amb}= 25^{\circ}\text{C}$

Parameter	Symbol	Value	Unit
Supply Voltage (Note 1)	V_{CC}	7.5~25	V
Peak Value of the Power MOSFET Drain Voltage	V_{DS}	-0.3~600	V
Low Voltage Terminal (CS, CAP, ZCD)		-0.3~6	V
Maximum Clamp Current for VCC Pin	I_{CC_MAX}	10	mA
Continuous Power Dissipation (Note 2)	P_{DMAX}	0.45	W
Thermal resistance	θ_{JA}	145	$^{\circ}\text{C}/\text{W}$
Junction Temperature	T_J	-40 to 150	$^{\circ}\text{C}$
Storage Temperature	T_{STG}	-55 to 150	$^{\circ}\text{C}$
ESD (HBM)		2	kV

Note 1: Exceed the limit parameter, the IC would be damaged.

Note2: The maximum power dissipation of IC falls along with the temperature, which determined by thermal resistance θ_{JA} , junction temperature T_J and ambient temperature T_A . The maximum allowed power dissipation is $P_{DMAX} = (T_{JMAX} - T_A) / \theta_{JA}$.

3. 2、Electrical Characteristics

Unless otherwise specified, $T_{amb}= 25^{\circ}\text{C}$

Parameter	Symbol	Test Conditions	Value			Unit
			Min.	Typ.	Max.	
Supply Voltage						
Supply range	V_{CC}		7.5	-	25	V
VCC turn on threshold	V_{CC_ON}	VCC Rising	15	17	19	V
VCC turn off threshold	V_{CC_OFF}	VCC Falling	6.5	7.5	9	V
VCC Clamp Voltage	V_{CC_CLAMP}			20		
VCC Start Up Current	I_{CC_ON}	VCC Rising $V_{CC}=V_{CC_ON}-1\text{V}$		30	50	μA
Operating current	I_{CC_OP}	$F_{OP}=10\text{kHz}$		300	600	μA
Zero Current Detector (ZCD)						
Zero current detect threshold	V_{ZCD_FALL}	ZCD Falling		0.2		V
Zero current detect hysteresis	V_{ZCD_HYS}	ZCD Rising		0.15		V
Output OVP Threshold	V_{ZCD_OVP}			1.6		V
Maximum On Time	T_{ON_MAX}			20		μs
Minimum Off Time	T_{OFF_MIN}			3		μs

To be continued

Continued

Parameter	Symbol	Test Conditions	Value			Unit	
			Min.	Typ.	Max.		
Maximum Off Time	T_{OFF_MAX}			100		μs	
Current Sense							
Peak Value Limit for CS Pin	V_{CS_LIMIT}			1		V	
Leading Edge Blanking Time	T_{LEB_CS}			360		ns	
Turn off delay time	T_{DELAY}			110		ns	
Error AMP							
current detect threshold	V_{REF}		0.194	0.2	0.206	V	
Lower clamp voltage for CAP Pin	V_{CAP_L}			1.5		V	
Linear operation range of CAP Pin	V_{CAP}		1.5		3.9	V	
Higher clamp voltage for CAP	V_{CAP_H}			4.0		V	
Power MOSFET							
The turn-on resistor of MOSFET	R_{DS_ON}	$V_{GS}=10V/I_{DS}=0.5A$	TCIL6568-7		9	12	Ω
		$V_{GS}=10V/I_{DS}=1A$	TCIL6568-14		4.5	6	Ω
Breakdown Voltage of MOSFET	BV_{DSS}	$V_{GS}=0V/I_{DS}=250\mu A$	600			V	
Leakage Current of MOSFET	I_{DSS}	$V_{GS}=0V/V_{DS}=600V$			10	μA	
Intelligent Thermal Adjust							
Over temperature adjust threshold	T_{ADJ}			150		$^{\circ}C$	

4、 Typical Application Circuit and Information

4. 1、 Application Circuit

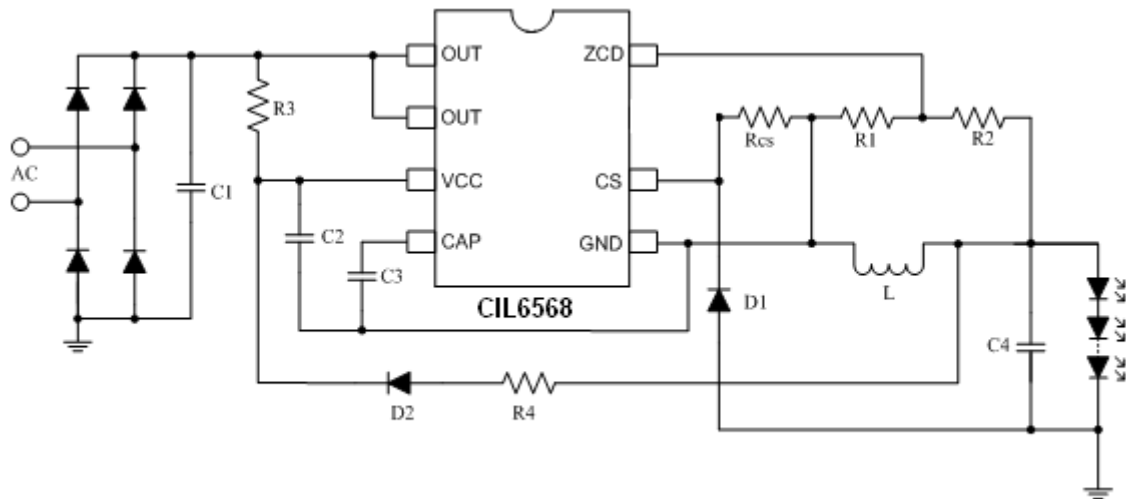

Fig.5 Typical Application Circuit

4. 2、 Application Instruction

1. The VCC bypass pin capacitor C2 should be placed close to the VCC pin and GND pin.
2. The ground copper connected to CS sample resistor should be as wide as possible and be minimized to ensure the veracity of current sensing. Otherwise, the regulate rate of output current will be effected. In addition, the signal ground copper should be connected to GND pin separately.
3. The voltage divider resistor connected to ZCD pin should be placed close to the ZCD pin, and the node should be placed far from the OUT pin line. Otherwise, the system noise will lead OVP protection by error. Decrease the ZCD divider resistor over the same proportion could reduce the disturbance from system noise.

5、 Package Information (Unit: mm)

5. 1、 Package Outline

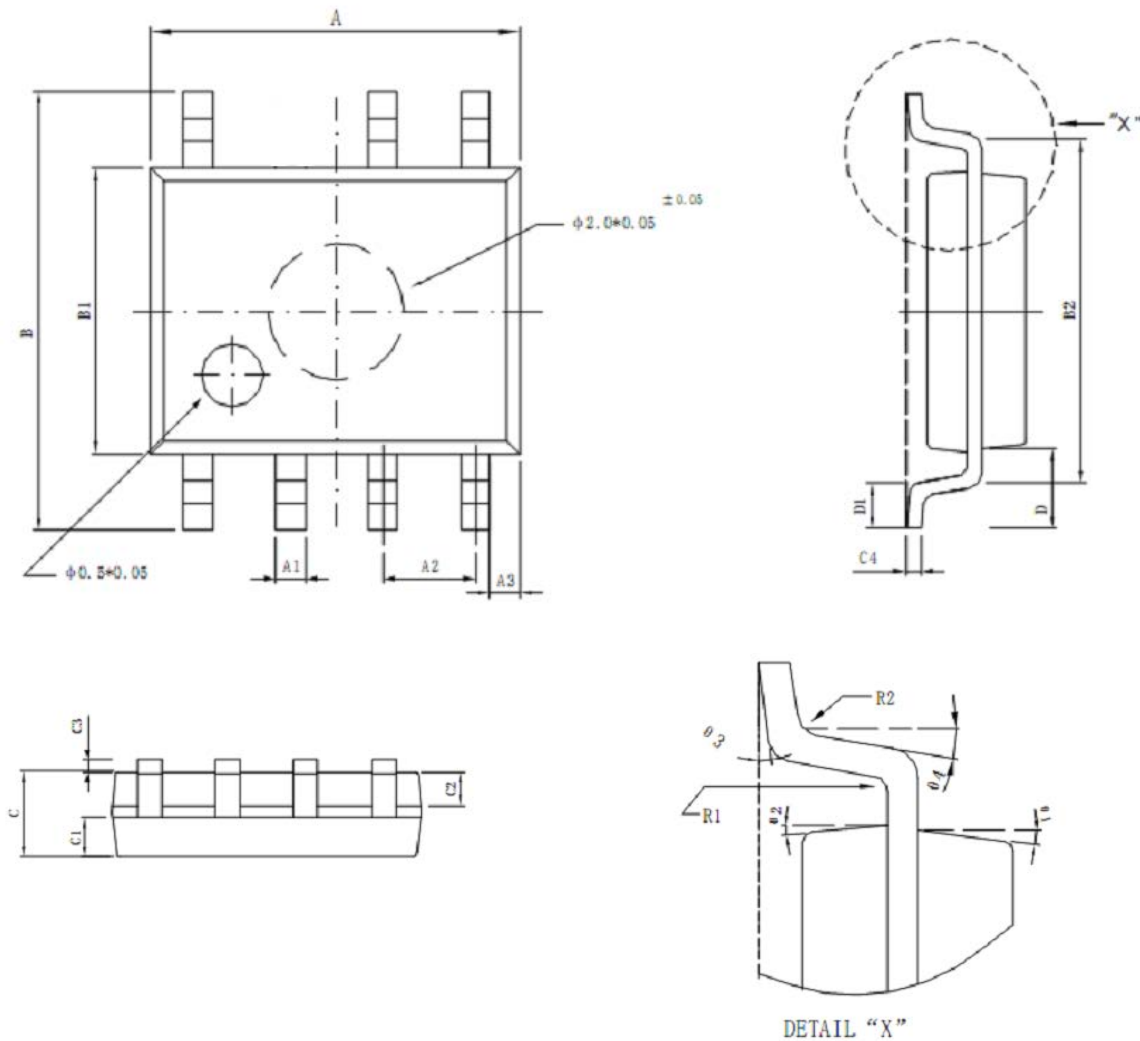

5. 2、 Dimensions

Symbol	Min.	Max.	Symbol	Min.	Max.
A	4.95	5.15	C3	0.10	0.20
A1	0.37	0.47	C4	0.20 TYP	
A2	1.27 TYP		D	1.05 TYP	
A3	0.41 TYP		D1	0.50 TYP	
B	5.80	6.20	R1	0.07 TYP	
B1	3.80	4.00	R2	0.07 TYP	
B2	5.0 TYP		$\theta 1$	17° TYP	
C	1.30	1.50	$\theta 2$	13° TYP	
C1	0.55	0.65	$\theta 3$	4° TYP	
C2	0.55	0.65	$\theta 4$	12° TYP	



Continental Device India Pvt. Ltd
An ISO/TS 16949, ISO 9001 and ISO 14001 Certified Company



TCIL6568

Disclaimer

The product information and the selection guides facilitate selection of the CDIL's Discrete Semiconductor Device(s) best suited for application in your product(s) as per your requirement. It is recommended that you completely review our Data Sheet(s) so as to confirm that the Device(s) meet functionality parameters for your application. The information furnished in the Data Sheet and on the CDIL Web Site/CD are believed to be accurate and reliable. CDIL however, does not assume responsibility for inaccuracies or incomplete information. Furthermore, CDIL does not assume liability whatsoever, arising out of the application or use of any CDIL product; neither does it convey any license under its patent rights nor rights of others. These products are not designed for use in life saving/support appliances or systems. CDIL customers selling these products (either as individual Discrete Semiconductor Devices or incorporated in their end products), in any life saving/support appliances or systems or applications do so at their own risk and CDIL will not be responsible for any damages resulting from such sale(s).

CDIL strives for continuous improvement and reserves the right to change the specifications of its products without prior notice.



CDIL is a registered Trademark of
Continental Device India Pvt. Ltd

C-120 Naraina Industrial Area, New Delhi 110 028, India.

Telephone + 91-11-2579 6150, 4141 1112 Fax + 91-11-2579 5290, 4141 1119

email@cdil.com www.cdil.com

CIN: U32109DL1964PTC004291

X-ON Electronics

Largest Supplier of Electrical and Electronic Components

Click to view similar products for [LED Display Drivers](#) category:

Click to view products by [CDIL](#) manufacturer:

Other Similar products are found below :

[MAP9000QNRH](#) [AP5726WUG-7](#) [AL8806QMP-13](#) [AP5726FDCG-7](#) [AS3693B-ZTQT](#) [AP5725WUG-7](#) [MAX139EQH+D](#) [STP16DP05PTR](#)
[STP16CPP05PTR](#) [STP16CPP05XTTR](#) [LV5236VZ-TLM-H](#) [BP9911CC](#) [ZXLD1366QEN8TC](#) [MT7725D](#) [TX6143](#) [SY6813PEC](#) [SD1002L4](#)
[AW3643CSR](#) [MP3370GN-Z](#) [LA2284L-G09-T](#) [SEDA](#) [SCT2027CSSG](#) [LYT3315D](#) [LYT3324D](#) [LYT4211E2](#) [LYT4214E2](#) [LYT4215E2](#)
[LYT4217E2](#) [LYT4218E2](#) [LYT4222E](#) [LYT4317E2](#) [LYT4321E](#) [LYT4323E](#) [LYT4324E3](#) [LYT4326E3](#) [TPS92020DR](#) [TPS92691PWPR](#)
[BCR420U](#) [HV9801ALG-G](#) [IS31FL3199-QFLS2-TR](#) [IS31FL3731-QFLS2-TR](#) [CAT4238TD](#) [SCT2001ASIG](#) [SCT2024CSTG](#) [SCT2167CSOG](#)
[SCT2167CSSG](#) [STP16CPPS05XTTR](#) [TLE4241GMFUMA1](#) [ICM7212MIQH+D](#) [ICM7212AIQH+D](#)