

Specification Sheet for Approved

Customer Name:	
Customer Part No.:	
Ceaiya Part No:	CWCI0805F Series
Spec No:	C-0805

【For Customer Approval Only】

If you Approval, Please Stamp

【RoHS Compliant Parts】

Approved By	Checked By	Prepared By
李庆辉	刘志坚	劳水花

深圳市柯爱亚电子有限公司

Shenzhen Ceaiya Electronics Co., Ltd.

深圳地址: 深圳市龙华区观湖街道鹭湖社区观盛二路 5 号捷顺科技中心 B706

东莞地址: 广东省东莞清溪镇青滨东路 105 号力合紫荆智能制造中心 10 栋一单元

Http://www.szceaiya.com Tel: 0769-89135516 Fax: 0769-89135519

Specification Sheet for SMD Chip Inductor

1. Scope

This specification applies to the CWCI0805F Series of wire wound SMD chip inductor.

2. Product Description and Identification (Part Number)

1) Description:

CWCI0805F series of Wire wound SMD chip inductor.

2) Product Identification (Part Number)

CWCI
0805
F
-
2R2
□
T
□□

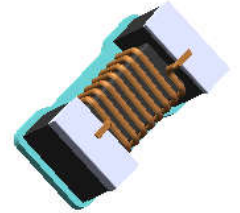

①	Type
CWCI	Wire Wound Chip Inductor

②	External Dimensions(L×W) 【inch】
0805	2.0mm×1.2mm

③	Material type
F	Ferrite

④	Nominal Inductance
Example	Nominal Value
1R0	1.0uH
100	10uH
101	100uH

⑤	Inductance Tolerance
J	±5%
K	±10%
M	±20%

⑦	Design Code
□□	Design Code
* Standard product is blank	

⑥	Packing
T	Tape Carrier Package

3. Electrical Characteristics

Please refer to Item 5.

- 1) Operating temperature range (individual chip without packing): -25°C ~ +100°C (Including Self-heating)
- 2) Storage temperature range (packaging conditions): -25°C ~ +100°C and RH 70% (Max.).

4. Shape and Dimensions (Unit:mm)

Dimensions and recommended PCB pattern for reflow soldering, please see Fig4-1 and Table4-1

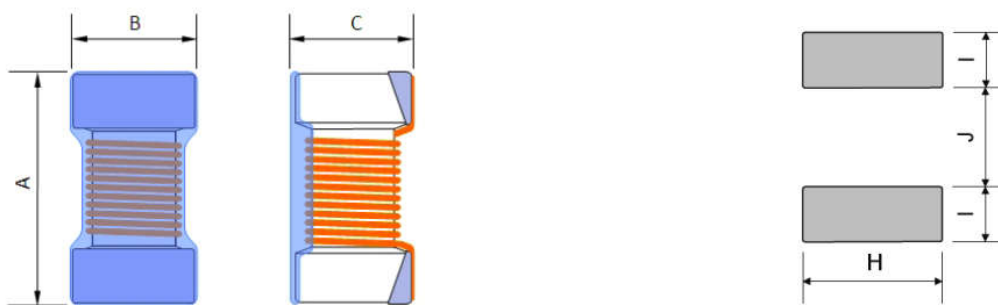

Fig4-1.

Table 4-1.

A	B	C	H	I	J
2.4 Max.	1.45Max.	1.4Max.	1.78 Ref	1.02 Ref	0.76 Ref

Specification Sheet for SMD Chip Inductor

5. Electrical Characteristics

Part Number	Inductance (uH)/MHz	Inductance Tolerance	Q/MHz Typ.	S.R.F Typ. (MHz)	RDCMax (Ω)	Irms Max. (mA)
CWCI0805F-1R0□T	1.0/7.9	J,K	14/7.9	208	0.17	1100
CWCI0805F-1R5□T	1.5/7.9	J,K	14/7.9	159	0.22	920
CWCI0805F-2R2□T	2.2/7.9	J,K	12/7.9	80	0.31	740
CWCI0805F-3R3□T	3.3/7.9	J,K	12/7.9	70	0.36	620
CWCI0805F-4R7□T	4.7/7.9	J,K	14/7.9	51	0.56	520
CWCI0805F-5R6□T	5.6/7.9	J,K	12/7.9	42	0.65	480
CWCI0805F-6R8□T	6.8/7.9	K,M	14/7.9	35	0.88	420
CWCI0805F-100□T	10/2.5	K,M	14/2.5	25	1.17	300
CWCI0805F-150□T	15/2.5	K,M	15/2.5	28	1.82	280
CWCI0805F-220□T	22/2.5	K,M	15/2.5	20	3.50	240

Note:

- When ordering, please specify tolerance and packaging codes. Ex:CWCI0805F-100KT
Tolerance: J=±5%,K=±10%,M=±20%, N=±30%
Packaging: Clear tape and reel {standard}
- L, Q, SRF : Agilent /HP 4287A + Agilent / HP 8722ES or Equivalent
- Rdc: Digital Milliohm Meter Chroma 16502, or equivalent.
- Idc for Inductance drop 20% from its value without current.
- Irms for a 15°C rise above 25°C ambient.

6. Structure: See the following.

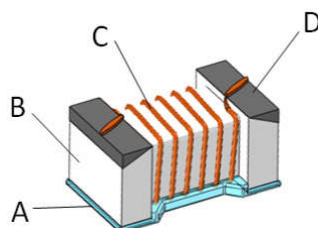

No.	Components	Material
A	Coating	Ultraviolet epoxy resin
B	Core	Ferrite
C	Wire	Polyurethane system enameled copper wire
D	Electrodes	Ag/Ag-Pd with Ni and Sn plating

Specification Sheet for SMD Chip Inductor

7. Reliability Test

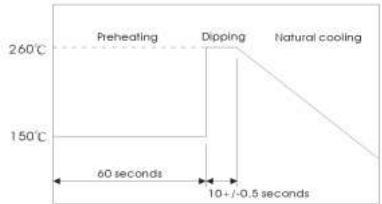
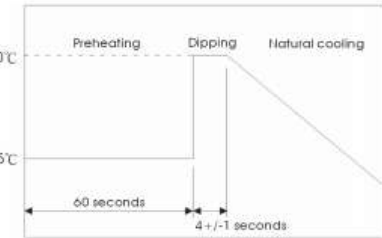
Items	Performance	Test Condition															
7.1 Solder Heat Resistance 耐焊锡热	Appearance: No significant abnormality. Inductance change: Within $\pm 20\%$ 外观：无明显异常 电感值：变化值在初始值 20% 以内	Preheat: 150°C , 60sec. Solder: H63A Solder temperature: $260\pm 5^{\circ}\text{C}$ Flux for lead free: rosin Dip time: $10\pm 0.5\text{sec}$. 预热： 150°C ， 60 sec 锡炉温度： $260\pm 5^{\circ}\text{C}$ 助焊剂： rosin. 时间： $10\pm 0.5\text{sec}$ 															
7.2 Solderability Test 端面焊锡性	More than 90% of the terminal electrode should be covered with solder. 端电极之锡覆盖面达 90% 以上	Preheat: $125\pm 25^{\circ}\text{C}$, 60sec. Solder: H63A Solder temperature: $230\pm 5^{\circ}\text{C}$ Flux for lead free: rosin Dip time: $4\pm 1\text{sec}$ 预热： 125°C ， 60 sec 锡炉温度： $230\pm 5^{\circ}\text{C}$ 助焊剂： rosin. 时间： $4\pm 1\text{sec}$ 															
7.3 High Temperature Resistance Test 高温放置测试	Appearance: no damage. Inductance: within $\pm 20\%$ of initial value. No disconnection or short circuit. 外观不能破损 电感值：变化值在初始值 20% 以内 电性无短路或断线。	Temperature: $85\pm 2^{\circ}\text{C}$. Applied current: rated current. Duration: 500 hrs															
7.4 Humidity Resistance Test 高湿放置测试	Appearance: no damage. Inductance: within $\pm 20\%$ of initial value. No disconnection or short circuit. 外观不能破损 电感值：变化值在初始值 20% 以内 电性无短路或断线。	Temperature: $40\pm 2^{\circ}\text{C}$. Applied current: rated current. Duration: 500 hrs Humidity: 90~95%															
7.5 Thermal shock 热冲击试验	Appearance: no damage. Inductance: within $\pm 20\%$ of initial value. No disconnection or short circuit. 外观不能破损 电感值：变化值在初始值 20% 以内 电性无短路或断线。	Condition for 1 cycle Step1: $-25\pm 2^{\circ}\text{C}$, 30 ± 3 min. Step2: Room temperature within 15 min. Step3: $+85\pm 5^{\circ}\text{C}$, 30 ± 3 min. Step4: Room temperature within 15 min. Number of cycles: 50PCS <table border="1" data-bbox="1134 1458 1485 1666"> <thead> <tr> <th>Phase</th> <th>Temperature($^{\circ}\text{C}$)</th> <th>Time(min)</th> </tr> </thead> <tbody> <tr> <td>1</td> <td>$-25\pm 2^{\circ}\text{C}$</td> <td>30 ± 3</td> </tr> <tr> <td>2</td> <td>Room Temp.</td> <td>15</td> </tr> <tr> <td>3</td> <td>$+85\pm 2^{\circ}\text{C}$</td> <td>30 ± 3</td> </tr> <tr> <td>4</td> <td>Room Temp.</td> <td>15</td> </tr> </tbody> </table>	Phase	Temperature($^{\circ}\text{C}$)	Time(min)	1	$-25\pm 2^{\circ}\text{C}$	30 ± 3	2	Room Temp.	15	3	$+85\pm 2^{\circ}\text{C}$	30 ± 3	4	Room Temp.	15
Phase	Temperature($^{\circ}\text{C}$)	Time(min)															
1	$-25\pm 2^{\circ}\text{C}$	30 ± 3															
2	Room Temp.	15															
3	$+85\pm 2^{\circ}\text{C}$	30 ± 3															
4	Room Temp.	15															
7.6 Humidity Resistance 高湿测试	Appearance: no damage. Inductance: within $\pm 20\%$ of initial value. No disconnection or short circuit. 外观不能破损 电感值：变化值在初始值 20% 以内 电性无短路或断线。	Humidity: 90~95%RH. Temperature: $40\pm 5^{\circ}\text{C}$. Applied current: rated current. Duration: $500\pm 12\text{hrs}$. Measured at room temperature after placing for 2 to 3hrs. 湿度： 90~95%RH. 温度： $40\pm 5^{\circ}\text{C}$. 须加电流： 额定电流。 放置时间： $500\pm 12\text{hrs}$.															

Specification Sheet for SMD Chip Inductor

8. Packaging and Storage

(1) Taping Dimensions (Unit: mm)

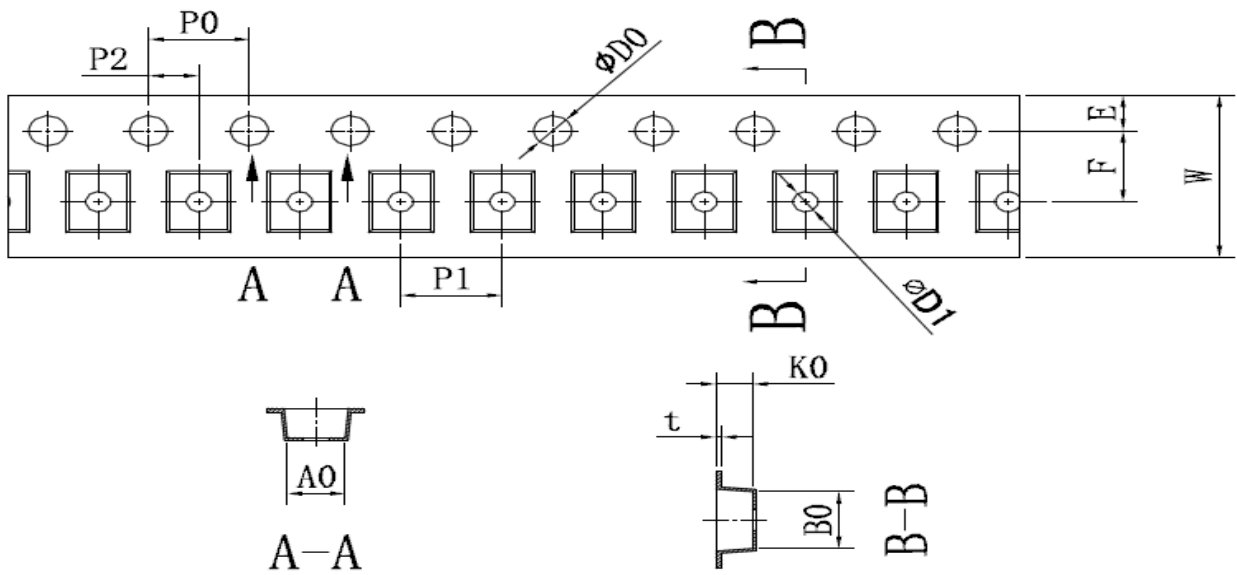

TEM	W	A0	B0	K0	P0	F	E	D0	D1	P1	P2	T
DIM	8.00	1.45	2.25	1.42	4.00	3.50	1.75	1.55	1.0	4.00	2.00	0.22
TOLE	±0.3	±0.1	±0.1	±0.05	±0.1	±0.05	±0.1	+0.1	+0.1	±0.1	±0.05	±0.05

包装数量(PACKAGING QUANTITY)

规格	0805
数量 (PCS)	2000

(2) Leader and blank portion

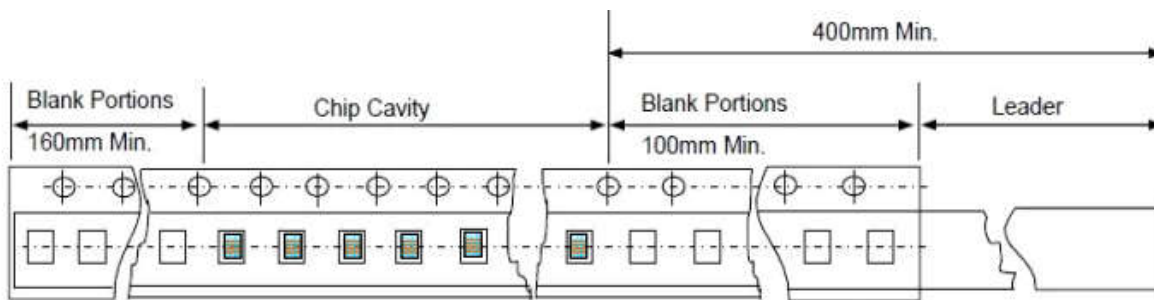

Fig. 7.1-3

Direction of Feed

Specification Sheet for SMD Chip Inductor

(3) Reel Dimensions (Unit: mm)

Dimensions (Unit: mm)

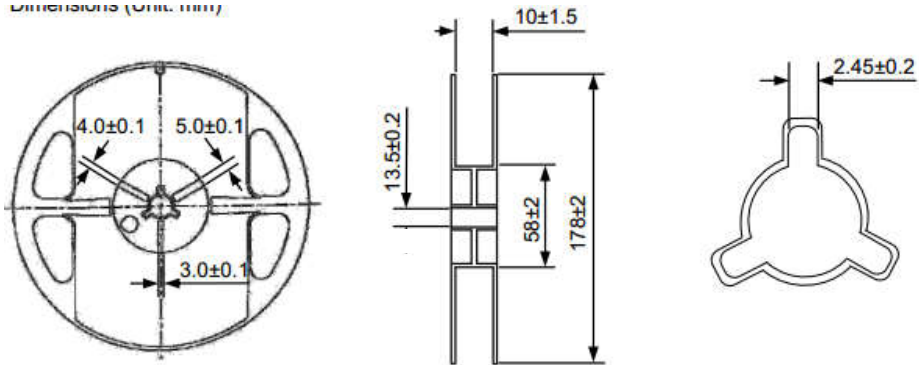

(4) Peeling off force: 10gf to 70gf in the direction show below.

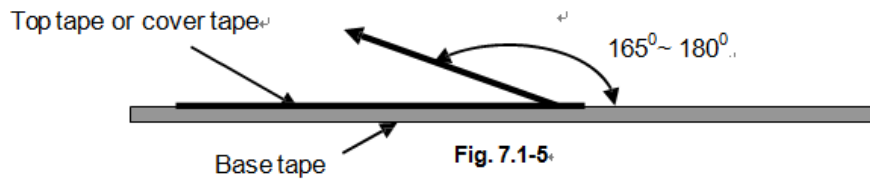

X-ON Electronics

Largest Supplier of Electrical and Electronic Components

Click to view similar products for [Fixed Inductors](#) category:

Click to view products by [Ceaiya](#) manufacturer:

Other Similar products are found below :

[CR32NP-100KC](#) [CR54NP-470LC](#) [70F224AI](#) [MGDQ4-00004-P](#) [MHQ1005P10NJ](#) [MHQ1005P1N0S](#) [MHQ1005P2N4S](#) [MHQ1005P3N6S](#)
[MHQ1005P5N1S](#) [MHQ1005P8N2J](#) [PE-53601NL](#) [PE-53602NL](#) [PG0936.113NLT](#) [9220-20](#) [9310-16](#) [PM06-2N7](#) [PM06-39NJ](#) [A01TK](#)
[1206CS-471XJ](#) [HC2-R47-R](#) [HC8-1R2-R](#) [HCF1305-3R3-R](#) [1206CS-151XG](#) [RCH664NP-140L](#) [RCH664NP-4R7M](#) [RCP1317NP-391L](#)
[RCR110DNP-331L](#) [DH2280-4R7M](#) [DS1608C-106](#) [B10TJ](#) [B82498B3101J000](#) [ELJ-RE27NJF2](#) [1812CS-153XJ](#) [1812CS-183XJ](#) [1812CS-](#)
[223XJ](#) [1812LS-104XJ](#) [1812LS-105XJ](#) [1812LS-124XJ](#) [1812LS-154XJ](#) [1812LS-223XJ](#) [1812LS-224XJ](#) [1812LS-563XJ](#) [1812LS-683XJ](#)
[1812LS-824XJ](#) [NIN-FB101JTR110F](#) [NIN-FB471JTR62F](#) [NIN-FC1R5JTR220F](#) [NIN-HCR15JTRF](#) [NIN-HCR33JTRF](#) [NIN-HDR22JTRF](#)