

# μPG2430T6Z

Data Sheet

GaAs Integrated Circuit  
 SP3T Switch for Bluetooth® and 802.11a/b/g

R09DS0030EJ0100  
 Rev.1.00  
 Oct 24, 2011

## DESCRIPTION

The μPG2430T6Z is a GaAs MMIC SP3T switch which was developed for Bluetooth, wireless LAN. This device can operate at frequencies from 0.5 to 6.0 GHz, with low insertion loss and high isolation. This device is housed in a 8-pin plastic TSON (Thin Small Out-line Non-leaded) package and is suitable for high-density surface mounting.

## FEATURES

- Switch Control voltage :  $V_{cont(H)} = 3.0\text{ V TYP.}, V_{cont(L)} = 0\text{ V TYP.}$
- Low insertion loss :  $L_{ins} = 0.55\text{ dB TYP. @ } f = 2.5\text{ GHz}$   
 :  $L_{ins} = 0.65\text{ dB TYP. @ } f = 6.0\text{ GHz}$
- High isolation :  $ISL = 28\text{ dB TYP. @ } f = 2.5\text{ GHz}$   
 :  $ISL = 25\text{ dB TYP. @ } f = 6.0\text{ GHz}$
- Handling power :  $P_{in(0.1\text{ dB})} = +28.0\text{ dBm TYP. @ } V_{cont(H)} = 3.0\text{ V}, V_{cont(L)} = 0\text{ V}$
- High-density surface mounting : 8-pin plastic TSON package (1.5 × 1.5 × 0.37 mm)

## APPLICATIONS

- Bluetooth and IEEE802.11a/b/g etc.

## ORDERING INFORMATION

Part Number	Order Number	Package	Marking	Supplying Form
μPG2430T6Z-E2	μPG2430T6Z-E2-A	8-pin plastic TSON (Pb-Free)	G6L	<ul style="list-style-type: none"> <li>• Embossed tape 8 mm wide</li> <li>• Pin 1, 8 face the perforation side of the tape</li> <li>• Qty 3 kpcs/reel</li> </ul>

**Remark** To order evaluation samples, please contact your nearby sales office.  
 Part number for sample order: μPG2430T6Z-A

### CAUTION

Although this device is designed to be as robust as possible, ESD (Electrostatic Discharge) can damage this device. This device must be protected at all times from ESD. Static charges may easily produce potentials of several kilovolts on the human body or equipment, which can discharge without detection. Industry-standard ESD precautions must be employed at all times.

## PIN CONNECTIONS AND INTERNAL BLOCK DIAGRAM

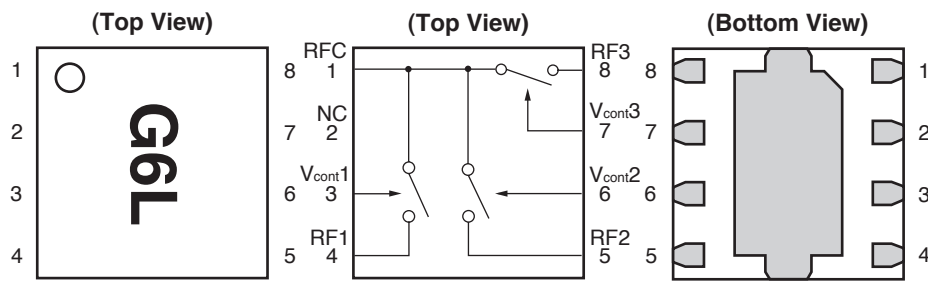

Pin No.	Pin Name
1	RFC
2	NC <sup>Note</sup>
3	V <sub>cont1</sub>
4	RF1
5	RF2
6	V <sub>cont2</sub>
7	V <sub>cont3</sub>
8	RF3

**Note:** Non-Connection**Remark** Exposed pad : GND

## TRUTH TABLE

V <sub>cont1</sub>	V <sub>cont2</sub>	V <sub>cont3</sub>	RFC–RF1	RFC–RF2	RFC–RF3
High	Low	Low	ON	OFF	OFF
Low	High	Low	OFF	ON	OFF
Low	Low	High	OFF	OFF	ON

ABSOLUTE MAXIMUM RATINGS (T<sub>A</sub> = +25°C, unless otherwise specified)

Parameter	Symbol	Ratings	Unit
Switch Control Voltage	V <sub>cont</sub>	+6.0 <sup>Note</sup>	V
Input Power (V <sub>cont (H)</sub> = 3.0 V)	P <sub>in</sub>	+32	dBm
Operating Ambient Temperature	T <sub>A</sub>	–45 to +85	°C
Storage Temperature	T <sub>stg</sub>	–55 to +150	°C

Note: |V<sub>cont (H)</sub> – V<sub>cont (L)</sub>| ≤ 6.0 VRECOMMENDED OPERATING RANGE (T<sub>A</sub> = +25°C)

Parameter	Symbol	MIN.	TYP.	MAX.	Unit
Operating Frequency	f	0.5	–	6.0	GHz
Switch Control Voltage (H)	V <sub>cont (H)</sub>	1.6	3.0	3.6	V
Switch Control Voltage (L)	V <sub>cont (L)</sub>	–0.2	0	0.2	V
Control Voltage Difference (H)	$\Delta$ V <sub>cont (H)</sub> <sup>Note 1</sup>	–0.1	0	0.1	V
Control Voltage Difference (L)	$\Delta$ V <sub>cont (L)</sub> <sup>Note 2</sup>	–0.1	0	0.1	V

Notes: 1.  $\Delta$ V<sub>cont (H)</sub> is a difference between the maximum and the minimum control voltages among V<sub>cont1 (H)</sub>, V<sub>cont2 (H)</sub> and V<sub>cont3 (H)</sub>.2.  $\Delta$ V<sub>cont (L)</sub> is a difference between the maximum and the minimum control voltages among V<sub>cont1 (L)</sub>, V<sub>cont2 (L)</sub> and V<sub>cont3 (L)</sub>.

**ELECTRICAL CHARACTERISTICS 1**

( $T_A = +25^\circ\text{C}$ ,  $V_{\text{cont (H)}} = 3.0\text{ V}$ ,  $V_{\text{cont (L)}} = 0\text{ V}$ ,  $Z_O = 50\ \Omega$ , DC blocking capacitors = 8 pF, unless otherwise specified)

Parameter	Symbol	Path	Test Conditions	MIN.	TYP.	MAX.	Unit
Insertion Loss	$L_{\text{ins}}$	RFC to RF1, 2, 3	$f = 0.5$ to $1.0\text{ GHz}$ <sup>Note 1</sup>	–	0.45	0.60	dB
			$f = 1.0$ to $2.0\text{ GHz}$ <sup>Note 1</sup>	–	0.45	0.60	dB
			$f = 2.0$ to $2.5\text{ GHz}$	–	0.55	0.70	dB
			$f = 2.5$ to $4.9\text{ GHz}$	–	0.60	0.80	dB
			$f = 4.9$ to $6.0\text{ GHz}$	–	0.65	0.90	dB
Isolation	ISL	RFC to RF1, 2, 3 (OFF)	$f = 0.5$ to $1.0\text{ GHz}$ <sup>Note 1</sup>	24	28	–	dB
			$f = 1.0$ to $2.0\text{ GHz}$ <sup>Note 1</sup>	24	28	–	dB
			$f = 2.0$ to $2.5\text{ GHz}$	23	28	–	dB
			$f = 2.5$ to $4.9\text{ GHz}$	23	28	–	dB
			$f = 4.9$ to $6.0\text{ GHz}$	20	25	–	dB
Return Loss	RL		$f = 0.5$ to $1.0\text{ GHz}$ <sup>Note 1</sup>	–	23	–	dB
			$f = 1.0$ to $2.0\text{ GHz}$ <sup>Note 1</sup>	16	23	–	dB
			$f = 2.0$ to $2.5\text{ GHz}$	16	23	–	dB
			$f = 2.5$ to $4.9\text{ GHz}$	16	23	–	dB
			$f = 4.9$ to $6.0\text{ GHz}$	10	23	–	dB
0.1 dB Loss Compression Input Power <sup>Note 2</sup>	$P_{\text{in (0.1 dB)}}$	RFC to RF1, 2, 3	$f = 2.5\text{ GHz}$	+25.0	+28.0	–	dBm
			$f = 6.0\text{ GHz}$	+25.0	+28.0	–	dBm
1 dB Loss Compression Input Power <sup>Note 3</sup>	$P_{\text{in (1 dB)}}$	RFC to RF1, 2, 3	$f = 2.5\text{ GHz}$	+28.0	+31.0	–	dBm
			$f = 6.0\text{ GHz}$	+28.0	+31.0	–	dBm
Input 3rd Order Intercept Point	IIP <sub>3</sub>		$f = 2.5\text{ GHz}$ , 2 tone, 5 MHz spacing	–	53	–	dBm
2nd Harmonics	2f <sub>0</sub>		$f = 2.5\text{ GHz}$ , $P_{\text{in}} = +22\text{ dBm}$	–	75	–	dBc
3rd Harmonics	3f <sub>0</sub>		$f = 2.5\text{ GHz}$ , $P_{\text{in}} = +22\text{ dBm}$	–	75	–	dBc
Switch Control Current	$I_{\text{cont}}$		No RF input	–	0.1	5.0	μA
Switch Control Speed	$t_{\text{sw}}$		50% CTL to 90/10% RF	–	50	300	ns

Notes: 1. DC blocking capacitors = 56 pF at  $f = 0.5$  to  $2.0\text{ GHz}$

2.  $P_{\text{in (0.1 dB)}}$  is the measured input power level when the insertion loss increases 0.1 dB more than that of the linear range.

3.  $P_{\text{in (1 dB)}}$  is the measured input power level when the insertion loss increases 1 dB more than that of the linear range.

**CAUTION**

It is necessary to use DC blocking capacitors with this device.

## ELECTRICAL CHARACTERISTICS 2

( $T_A = +25^\circ\text{C}$ ,  $V_{\text{cont (H)}} = 1.8\text{ V}$ ,  $V_{\text{cont (L)}} = 0\text{ V}$ ,  $Z_O = 50\ \Omega$ , DC blocking capacitors = 8 pF, unless otherwise specified)

Parameter	Symbol	Path	Test Conditions	MIN.	TYP.	MAX.	Unit
Insertion Loss	$L_{\text{ins}}$	RFC to RF1, 2, 3	$f = 0.5$ to $1.0\text{ GHz}$ <sup>Note 1</sup>	–	0.45	0.60	dB
			$f = 1.0$ to $2.0\text{ GHz}$ <sup>Note 1</sup>	–	0.45	0.60	dB
			$f = 2.0$ to $2.5\text{ GHz}$	–	0.55	0.70	dB
			$f = 2.5$ to $4.9\text{ GHz}$	–	0.60	0.80	dB
			$f = 4.9$ to $6.0\text{ GHz}$	–	0.65	0.90	dB
Isolation	ISL	RFC to RF1, 2, 3 (OFF)	$f = 0.5$ to $1.0\text{ GHz}$ <sup>Note 1</sup>	24	28	–	dB
			$f = 1.0$ to $2.0\text{ GHz}$ <sup>Note 1</sup>	24	28	–	dB
			$f = 2.0$ to $2.5\text{ GHz}$	23	28	–	dB
			$f = 2.5$ to $4.9\text{ GHz}$	23	28	–	dB
			$f = 4.9$ to $6.0\text{ GHz}$	20	25	–	dB
Return Loss	RL		$f = 0.5$ to $1.0\text{ GHz}$ <sup>Note 1</sup>	–	23	–	dB
			$f = 1.0$ to $2.0\text{ GHz}$ <sup>Note 1</sup>	16	23	–	dB
			$f = 2.0$ to $2.5\text{ GHz}$	16	23	–	dB
			$f = 2.5$ to $4.9\text{ GHz}$	16	23	–	dB
			$f = 4.9$ to $6.0\text{ GHz}$	10	23	–	dB
0.1 dB Loss Compression Input Power <sup>Note 2</sup>	$P_{\text{in (0.1 dB)}}$	RFC to RF1, 2, 3	$f = 2.5\text{ GHz}$	+20.0	+23.0	–	dBm
			$f = 6.0\text{ GHz}$	+19.0	+22.0	–	dBm
1 dB Loss Compression Input Power <sup>Note 3</sup>	$P_{\text{in (1 dB)}}$	RFC to RF1, 2, 3	$f = 2.5\text{ GHz}$	+24.0	+27.0	–	dBm
			$f = 6.0\text{ GHz}$	+22.0	+25.0	–	dBm
Input 3rd Order Intercept Point	$IIP_3$		$f = 2.5\text{ GHz}$ , 2 tone, 5 MHz spacing	–	50	–	dBm
2nd Harmonics	$2f_0$		$f = 2.5\text{ GHz}$ , $P_{\text{in}} = +17\text{ dBm}$	–	75	–	dBc
3rd Harmonics	$3f_0$		$f = 2.5\text{ GHz}$ , $P_{\text{in}} = +17\text{ dBm}$	–	75	–	dBc
Switch Control Current	$I_{\text{cont}}$		No RF input	–	0.1	5.0	$\mu\text{A}$
Switch Control Speed	$t_{\text{sw}}$		50% CTL to 90/10% RF	–	100	600	ns

Notes: 1. DC blocking capacitors = 56 pF at  $f = 0.5$  to  $2.0\text{ GHz}$

2.  $P_{\text{in (0.1 dB)}}$  is the measured input power level when the insertion loss increases 0.1 dB more than that of the linear range.

3.  $P_{\text{in (1 dB)}}$  is the measured input power level when the insertion loss increases 1 dB more than that of the linear range.

### CAUTION

It is necessary to use DC blocking capacitors with this device.

## EVALUATION CIRCUIT

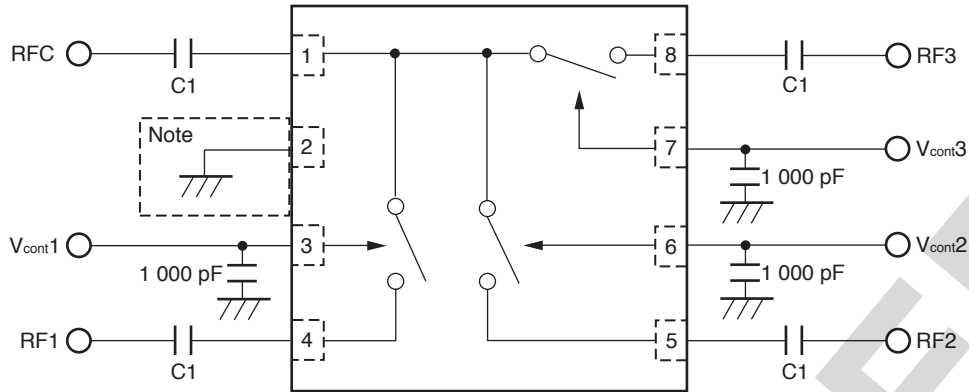

Note: It is recommended to connect the pin directly to the ground, or not to connect the pin to anything.

**Remarks** C1 : 0.5 to 2.0 GHz      56 pF  
                   : 2.0 to 6.0 GHz      8 pF

The application circuits and their parameters are for reference only and are not intended for use in actual design-ins.

## APPLICATION INFORMATION

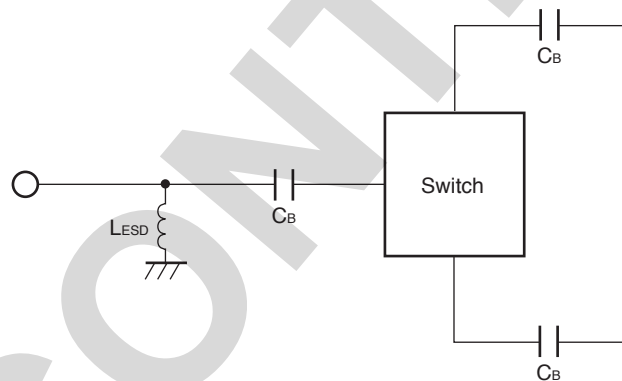

- $C_B$  are DC blocking capacitors external to the device.  
 A value of 8 pF is sufficient for operation from 2 GHz to 6 GHz bands.  
 The value may be tailored to provide specific electrical responses.
- The RF ground connections should be kept as short as possible and connected to directly to a good RF ground for best performance.
- $L_{ESD}$  provides a means to increase the ESD protection on a specific RF port, typically the port attached to the antenna.

**TYPICAL CHARACTERISTICS**

( $V_{cont(H)} = 3.0\text{ V}$ ,  $V_{cont(L)} = 0\text{ V}$ ,  $Z_O = 50\ \Omega$ , DC blocking capacitors = 8 pF, unless otherwise specified)

RFC-RF1/RF2/RF3  
INSERTION LOSS vs. FREQUENCY

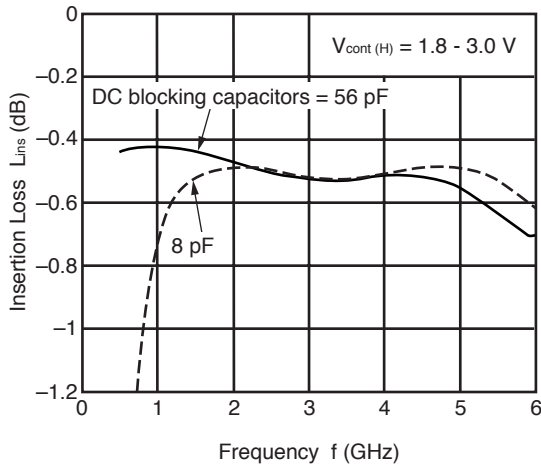

RFC-RF1/RF2/RF3  
ISOLATION vs. FREQUENCY

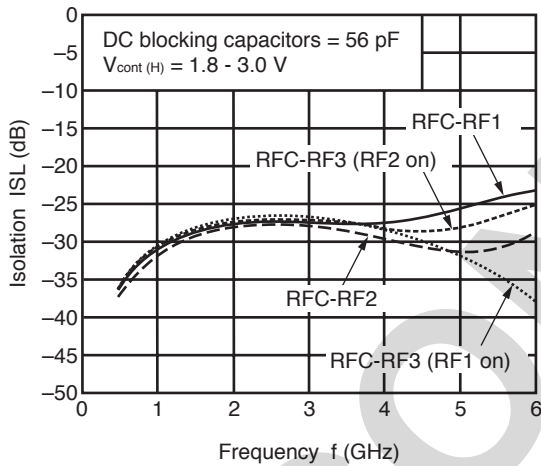

RFC-RF1/RF2/RF3  
ISOLATION vs. FREQUENCY

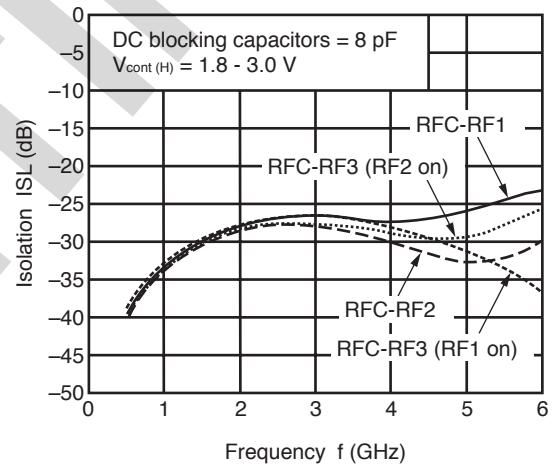

RETURN LOSS (RFC) vs. FREQUENCY

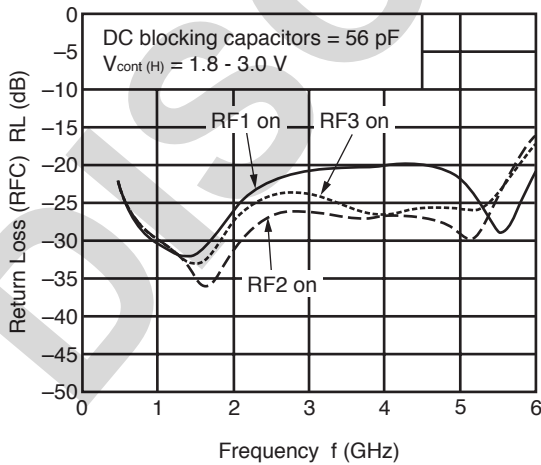

RETURN LOSS (RFC) vs. FREQUENCY

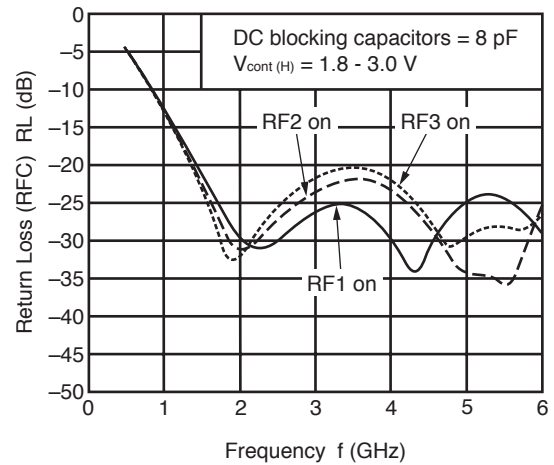

**Remark** The graphs indicate nominal characteristics.

RETURN LOSS (RF1, 2, 3) vs. FREQUENCY

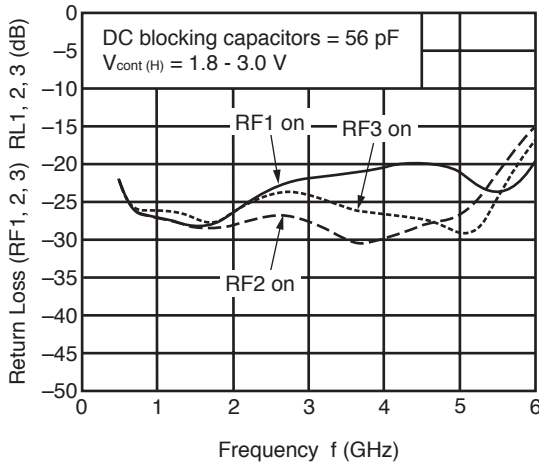

RETURN LOSS (RF1, 2, 3) vs. FREQUENCY

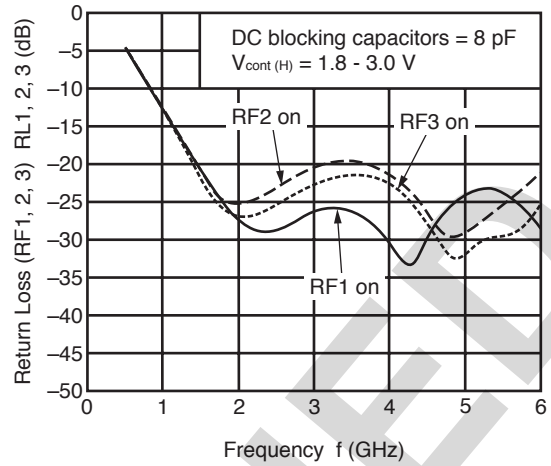

RFC-RF1/RF2/RF3 INSERTION LOSS vs. SWITCH CONTROL VOLTAGE (H)

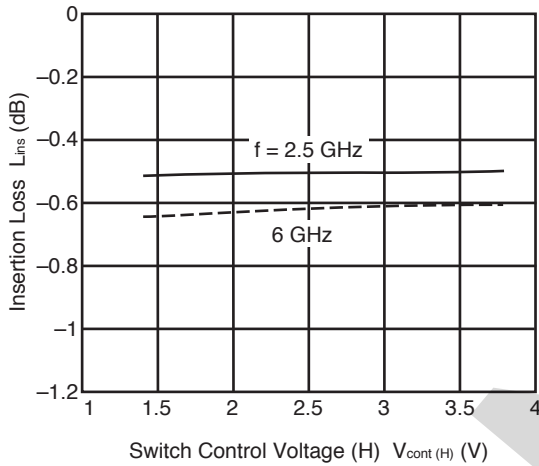

RFC-RF1/RF2/RF3 ISOLATION vs. SWITCH CONTROL VOLTAGE (H)

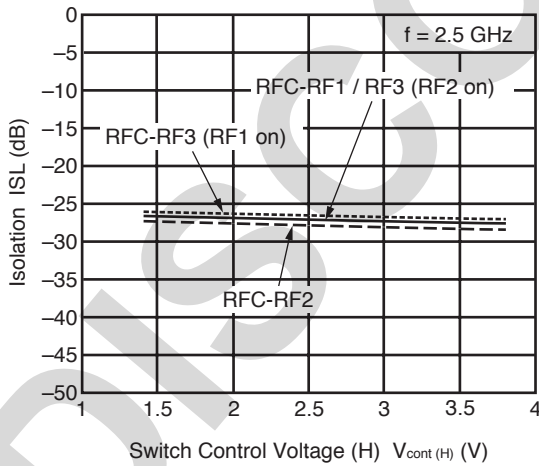

RFC-RF1/RF2/RF3 ISOLATION vs. SWITCH CONTROL VOLTAGE (H)

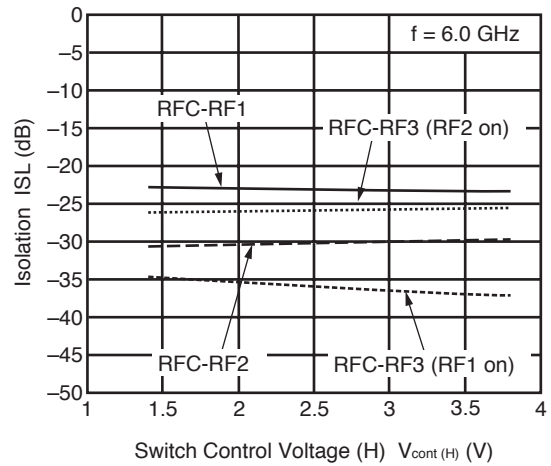

**Remark** The graphs indicate nominal characteristics.

RETURN LOSS (RFC)  
vs. SWITCH CONTROL VOLTAGE (H)

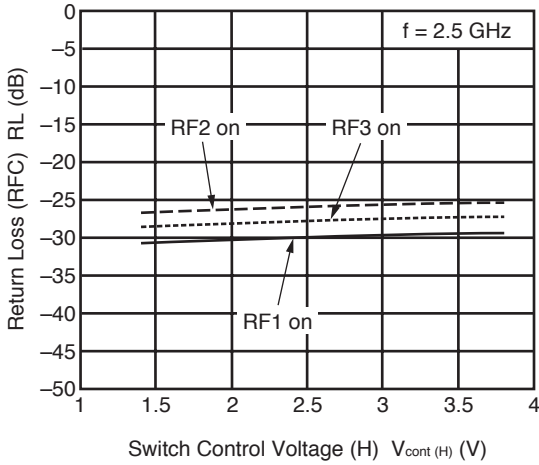

RETURN LOSS (RFC)  
vs. SWITCH CONTROL VOLTAGE (H)

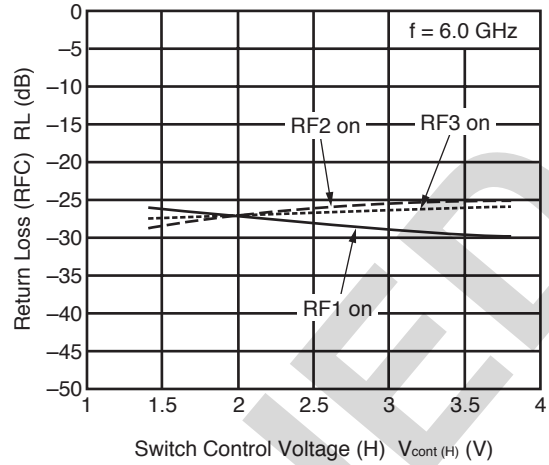

RETURN LOSS (RF1, 2, 3)  
vs. SWITCH CONTROL VOLTAGE (H)

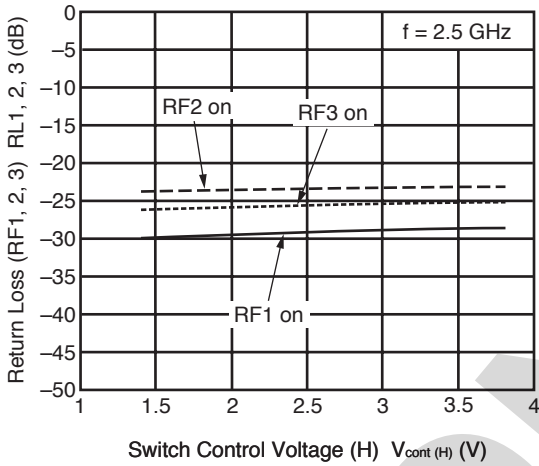

RETURN LOSS (RF1, 2, 3)  
vs. SWITCH CONTROL VOLTAGE (H)

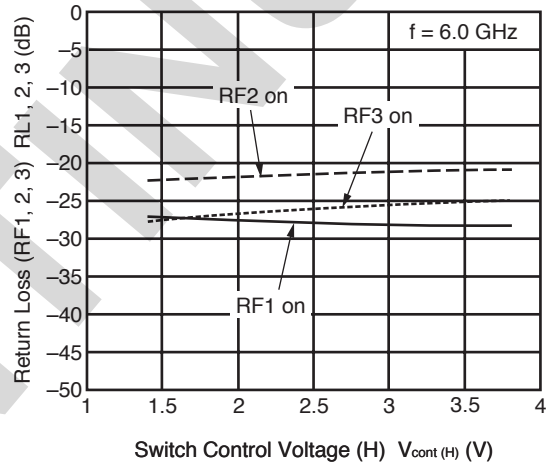

RFC-RF1/RF2/RF3 INSERTION LOSS,  
Icont vs. INPUT POWER

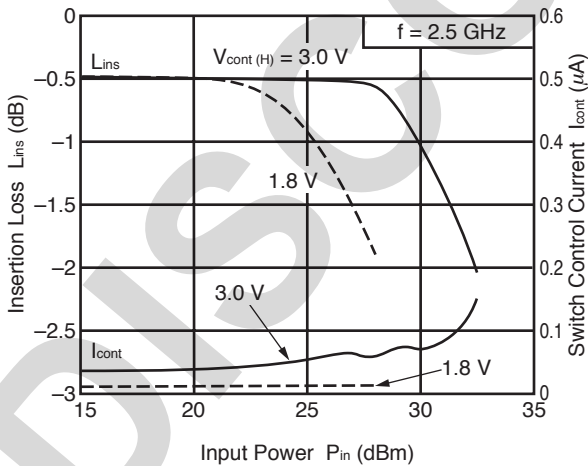

RFC-RF1/RF2/RF3 INSERTION LOSS,  
Icont vs. INPUT POWER

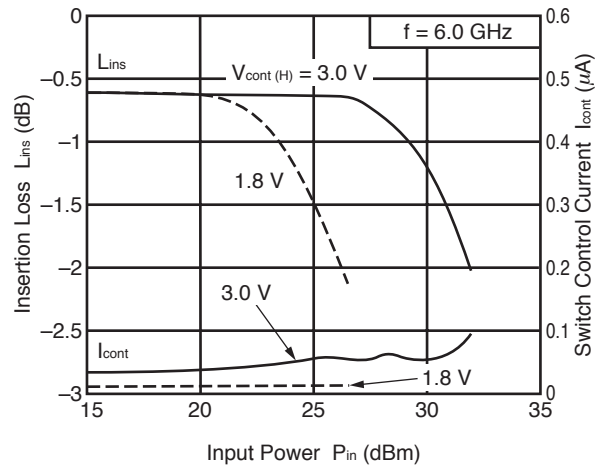

**Remark** The graphs indicate nominal characteristics.



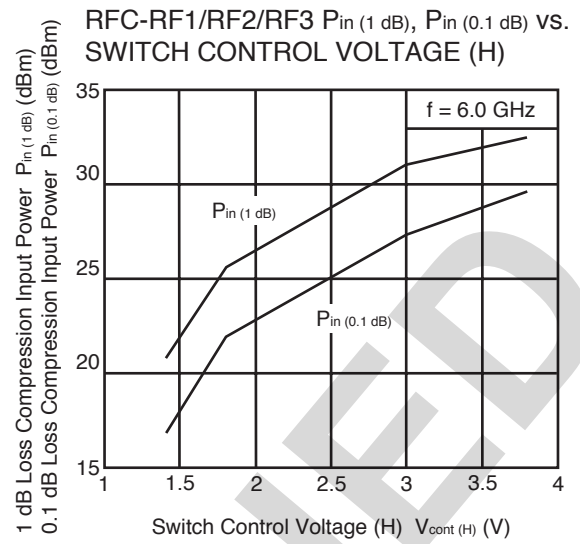
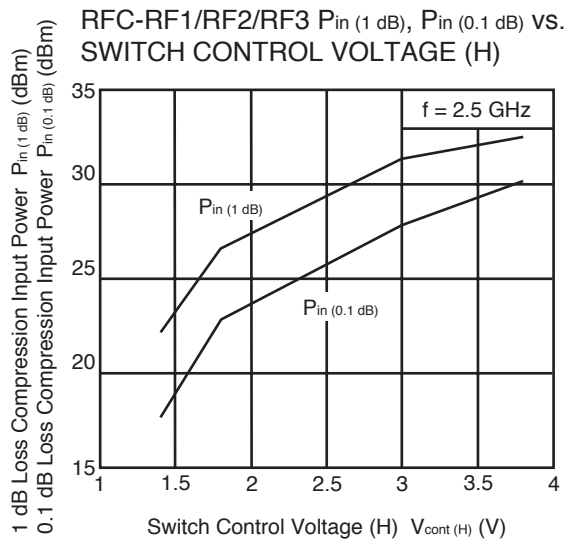

**Remark** The graphs indicate nominal characteristics.

DISCONTINUED

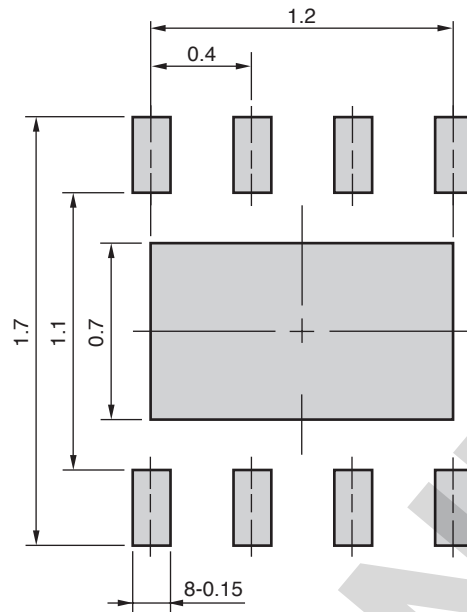
**MOUNTING PAD LAYOUT DIMENSIONS****8-PIN PLASTIC TSON (UNIT: mm)**

**Remark** The mounting pad layout in this document is for reference only.  
When designing PCB, please consider workability of mounting, solder joint reliability, prevention of solder bridge and so on, in order to optimize the design.

**PACKAGE DIMENSIONS**

**8-PIN PLASTIC TSON (UNIT: mm)**

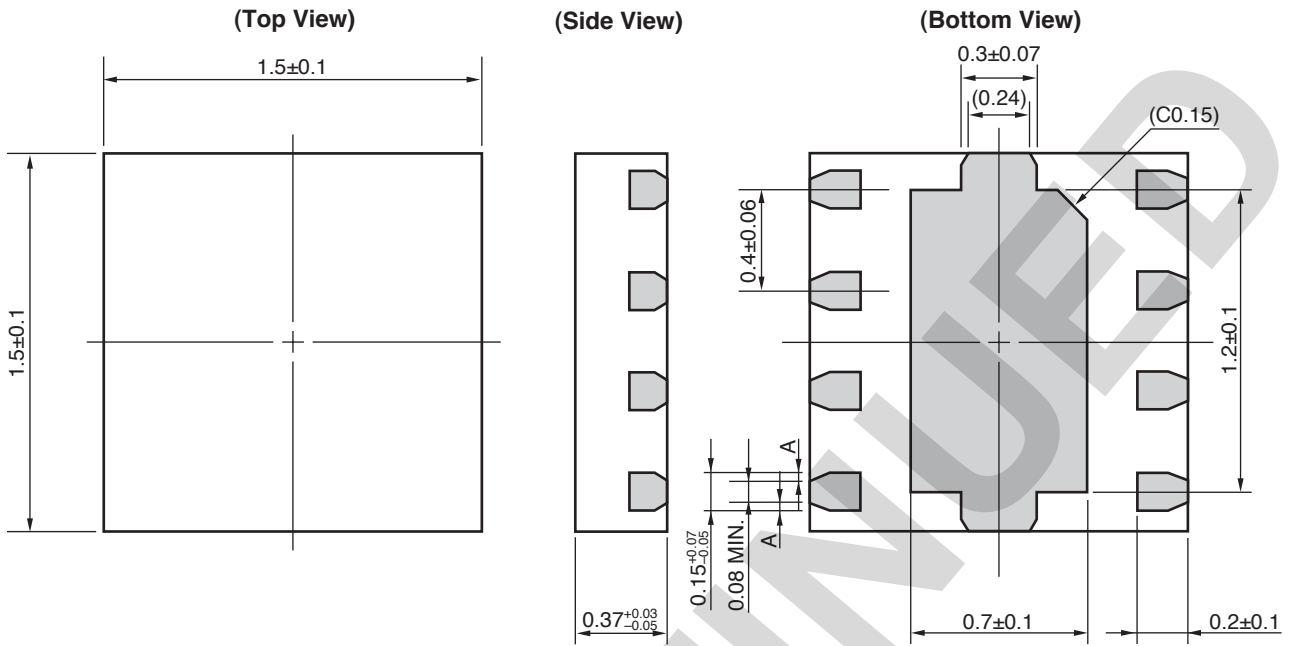

**Remark** A > 0  
 ( ): Reference value

DISCONTINUED

**RECOMMENDED SOLDERING CONDITIONS**

This product should be soldered and mounted under the following recommended conditions. For soldering methods and conditions other than those recommended below, contact your nearby sales office.

Soldering Method	Soldering Conditions	Condition Symbol
Infrared Reflow	Peak temperature (package surface temperature) : 260°C or below Time at peak temperature : 10 seconds or less Time at temperature of 220°C or higher : 60 seconds or less Preheating time at 120 to 180°C : 120±30 seconds Maximum number of reflow processes : 3 times Maximum chlorine content of rosin flux (% mass) : 0.2% (Wt.) or below	IR260
Partial Heating	Peak temperature (terminal temperature) : 350°C or below Soldering time (per side of device) : 3 seconds or less Maximum chlorine content of rosin flux (% mass) : 0.2% (Wt.) or below	HS350

**CAUTION**

Do not use different soldering methods together (except for partial heating).

<b>Caution</b>	GaAs Products	<p>This product uses gallium arsenide (GaAs). GaAs vapor and powder are hazardous to human health if inhaled or ingested, so please observe the following points.</p> <ul style="list-style-type: none"><li>• Follow related laws and ordinances when disposing of the product. If there are no applicable laws and/or ordinances, dispose of the product as recommended below.<ol style="list-style-type: none"><li>1. Commission a disposal company able to (with a license to) collect, transport and dispose of materials that contain arsenic and other such industrial waste materials.</li><li>2. Exclude the product from general industrial waste and household garbage, and ensure that the product is controlled (as industrial waste subject to special control) up until final disposal.</li></ol></li><li>• Do not burn, destroy, cut, crush, or chemically dissolve the product.</li><li>• Do not lick the product or in any way allow it to enter the mouth.</li></ul>
----------------	---------------	--

DISCONTINUED

<b>Revision History</b>	<b>μPG2430T6Z Data Sheet</b>
-------------------------	------------------------------

Rev.	Date	Description	
		Page	Summary
1.00	Oct 24, 2011	-	First edition issued

DISCONTINUED

Bluetooth is a registered trademark owned by Bluetooth SIG, Inc., U.S.A.

All trademarks and registered trademarks are the property of their respective owners.
---

## X-ON Electronics

Largest Supplier of Electrical and Electronic Components

*Click to view similar products for [RF Switch ICs](#) category:*

*Click to view products by [CEL](#) manufacturer:*

Other Similar products are found below :

[MASW-007921-002SMB](#) [BGSA142GN12E6327XTSA1](#) [BGSA142MN12E6327XTSA1](#) [BGSA142M2N12E6327XTSA1](#) [MASW-004100-11930W](#) [MASW-008853-TR3000](#) [BGS13SN8E6327XTSA1](#) [BGSF18DM20E6327XUMA1](#) [BGSX210MA18E6327XTSA1](#) [BGSX212MA18E6327XTSA1](#) [SKY13446-374LF](#) [SW-227-PIN](#) [PE42524A-X](#) [CG2185X2](#) [CG2415M6](#) [MA4AGSW1A](#) [MA4AGSW2](#) [MA4AGSW3](#) [MA4AGSW5](#) [MA4SW210B-1](#) [MA4SW410](#) [MASW-002102-13580G](#) [BGS 12PL6 E6327](#) [BGS1414MN20E6327XTSA1](#) [BGS1515MN20E6327XTSA1](#) [BGSA11GN10E6327XTSA1](#) [BGSX28MA18E6327XTSA1](#) [HMC199AMS8](#) [HMC595AETR](#) [HMC986A](#) [SKY13374-397LF](#) [SKY13453-385LF](#) [CG2430X1-C2](#) [TGS4304](#) [UPG2162T5N-A](#) [CG2415M6-C2](#) [AS222-92LF](#) [SW-314-PIN](#) [UPG2162T5N-E2-A](#) [BGS18GA14E6327XTSA1](#) [MASWSS0204TR-3000](#) [MASWSS0201TR](#) [MASWSS0181TR-3000](#) [MASW-007588-TR3000](#) [MASW-007075-000100](#) [MASW-004103-13655P](#) [MASW-003102-13590G](#) [MASWSS0202TR-3000](#) [MASW-008543-TR3000](#) [MA4SW310B-1](#)