

MOSFET BASED DC SOLID-STATE RELAY

- ▶ Latest MOSFET technology generation.
- ▶ Ultra low on-state resistance.
- ▶ Low output leakage current.
- ▶ Low control current consumption.
- ▶ Built-in overvoltage protection
- ▶ Reverse protected triggered control input to avoid linear control risks
- ▶ No radiated or conducted disturbances
- ▶ Touch protected housing IP20



SOM02060



Control voltage range	3.5-32VDC
Max. permanent output voltage	40VDC
Max. load current with heatsink	20ADC

Load voltage range	Load current range	Control input voltage range	In & case / Out Insulation	Connections	Dimensions (WxHxD)	Weight
5-40VDC	Up to 20A (with heatsink)	3.5-32VDC	2.5kV	Screw terminals	45 x 58.5 x 30	80g

Fig. 1 HIGH SIDE WIRING DIAGRAM (Load connected to “-“) **Fig. 2 LOW SIDE WIRING DIAGRAM (Load connected to “+“)**

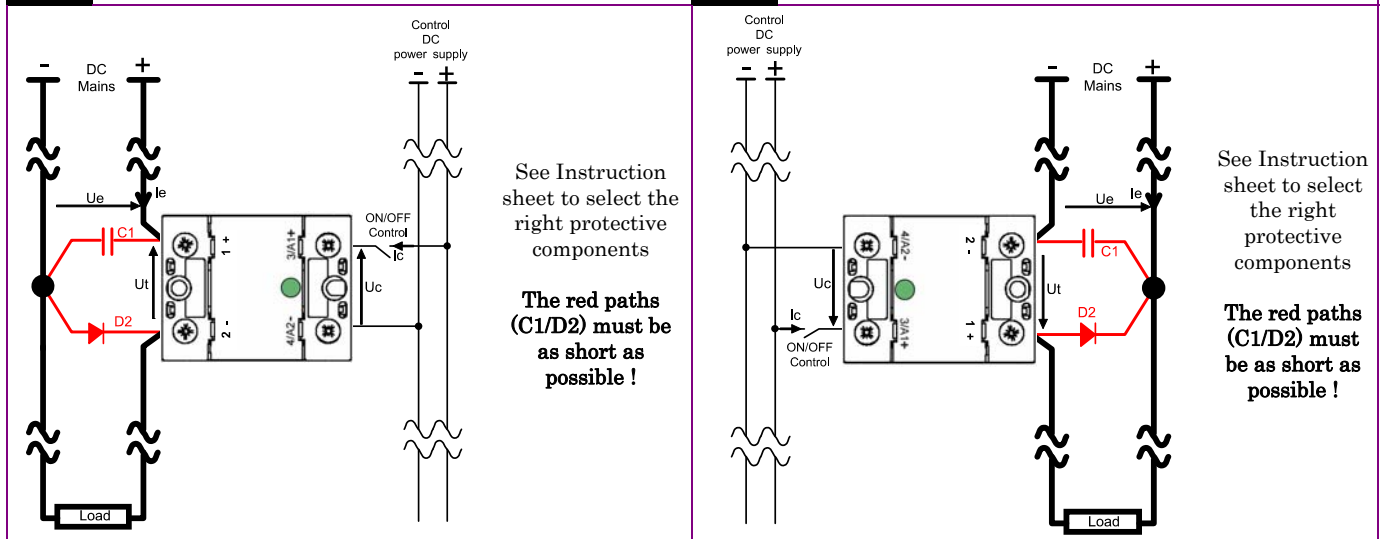
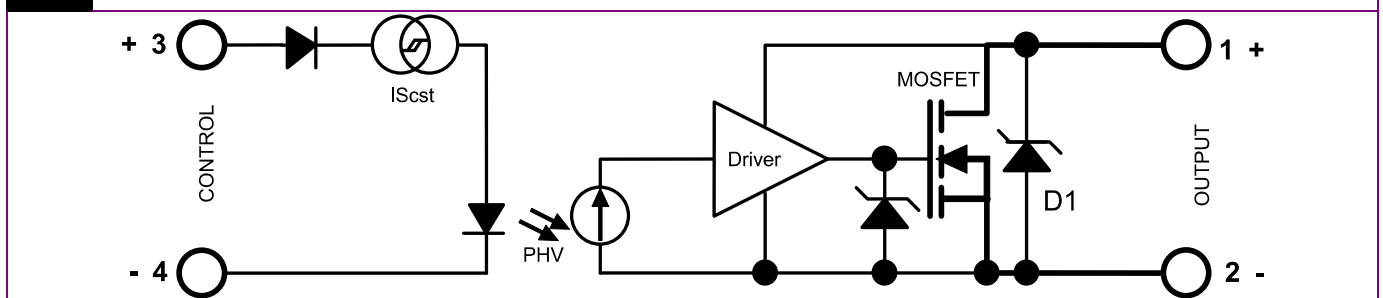

Fig. 3 INTERNAL DIAGRAM



Proud to serve you

CONTROL INPUT CHARACTERISTICS

INPUT CIRCUIT	CHARACTERISTIC	LABEL	VALUE	INFO.
	Nom. Control voltage	Ucnom	12-24VDC	
	Min. Control current	Icmin	35mADC	-100µA/°C
	Control voltage range	Uc	3.5 – 32VDC	typical ON=3.3V
	Control current consumption	Ic	32 – 35mADC (for control voltage range)	See fig. 5
	Releasing control voltage	Ucoffmax	1VDC	typical OFF= 2.6V
	Max. reverse control voltage	-Ucmax	32VDC	-Icmax<100µA
	Input impedance	Rin	Current limitation	See fig. 5

POWER OUTPUT CHARACTERISTICS

POWER CIRCUIT	CHARACTERISTIC	LABEL	VALUE	INFO.
	Nominal voltage	Uenom	24VDC	
	Voltage range	Ut Ue	5-40VDC	
	Non-repetitive peak voltage	Utp	60V	
	Overvoltage protection	D1	Transient voltage suppressor 39V (1500W/1ms)	
	Max reverse voltage drop (internal diode at OFF state)	-Ut	1.5V	@Ie=55A @Uc=0
	Maximum nominal currents	Ie max	Resistive 20A	Motor Please contact us
	Non-repetitive peak overload current	Id max	200A	See fig. 8
	Min. load current	Iemin	5mA	
	Max. leakage current	Ielk max	3mA	@Utmax @Tjmax
	Max. on-state resistance	RDson	36mΩ	@Iemax @Tjmax
	Typ. output capacitance	Cout	0.3nF	
	Junction/case thermal resistance per power element	Rthjc	1.8K/W	
	Built-in heatsink thermal resistance vertically mounted	Rthra	10K/W	@ΔTra=75°C
	Heatsink thermal time constant	Tthra	10 minutes	@ΔTra=40°C
	Control inputs/power outputs insulation voltage	Uimp	2.5kV	
	Inputs/case insulation voltage	Uimp	2.5kV	
	Outputs/case insulation voltage	Uimp	2.5kV	
	Isolation resistance	Rio	1GΩ	
	Isolation capacitance	Cio	<8pF	
	Maximum junction temperature	Tjmax	175°C	
	Storage ambient temperature	Tstg	-40->+100°C	
	Operating ambient temperature	Tamb	-25->+90°C	See fig. 7
	Max. case temperature	Tc	100°C	

PROTECTION CHARACTERISTICS

PROTECTION	Leakage current (Ielk) vs DC voltage (Ut)	Absolute limits

Ielk : Leakage current of the relay
Ie : User load nominal current
Utp : Relay max. non repetitive peak voltage
Utmax : Max. nominal voltage of the relay
Uto : Possible overvoltage above Utmax
Utn = Ue : User DC power supply voltage
t : Overvoltage duration
T : Time between 2 overvoltage

TIME CHARACTERISTICS

Fig. 4

TIME DIAGRAMS

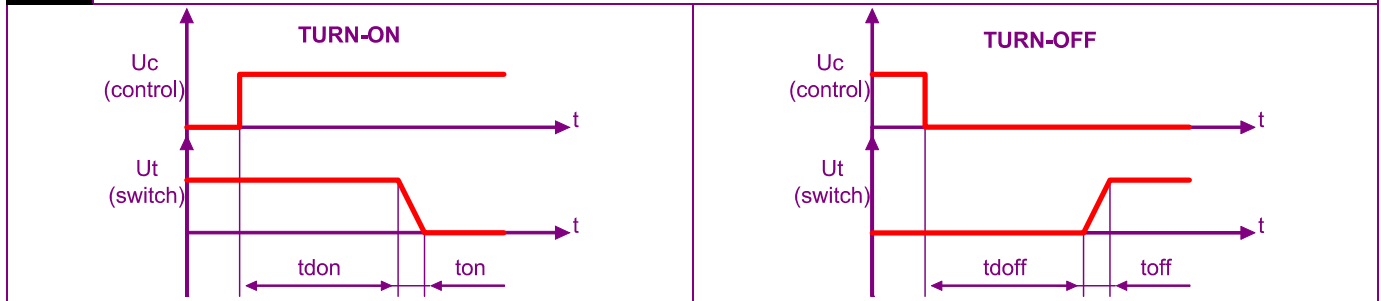

TIME CHARACTERISTIC	CHARACTERISTIC	LABEL	VALUE	INFO.
	Turn on time	ton	20µs	
	Turn on delay	tdon	20µs	
	Turn off time	toff	20µs	
	Turn off delay	tdoff	20µs	
Max. On-Off frequency	F_(on-off)	>1000Hz (for high frequency, take 2 x I _e to calculate the heatsink; the protections must be chosen carefully)	Refer to the instruction sheet	

GENERAL INFORMATION

MISC.	Display		Green LED (indicates relay has switched ON)	
	Housing		UL94V0	
	Mounting		2 screws (M4x12mm ; tightening = 1.2N.m)	See mounting sheet
	Noise level		None	
	Weight		80g	

STANDARDS

GENERAL	Standards		IEC60947-1	
	Protection level		IP20	
	Protection against direct touch		Yes	
	CE marking		Yes	
	UL, cULUS		Yes	

E.M.C. IMMUNITY	TYPE OF TEST	STANDARD	LEVEL	EFFECT
	Fast transients bursts	EN61000-4-4	4kV criterion B	
	Electric chocks	EN61000-4-5	1kV criterion B	
	Voltage drop	EN61000-4-11	-	

CHARACTERISTIC CURVES

Fig. 5

INPUT CHARACTERISTIC

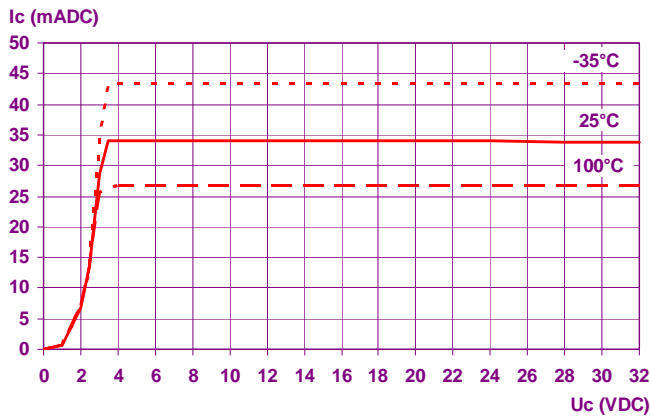

Fig. 6

ON RESISTANCE VS JUNCTION TEMPERATURE

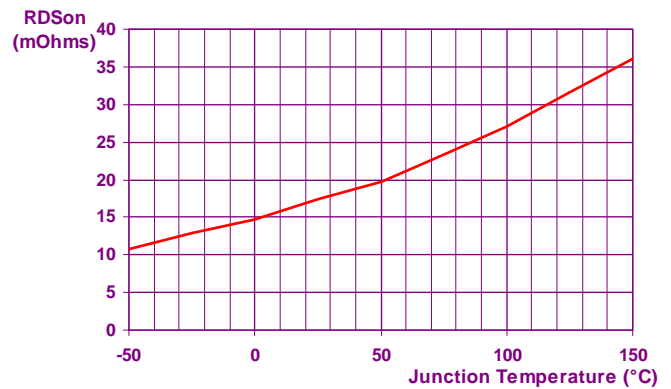

Fig. 7

POWER DISSIPATED AND LOAD CURRENT LIMIT VS TEMPERATURE

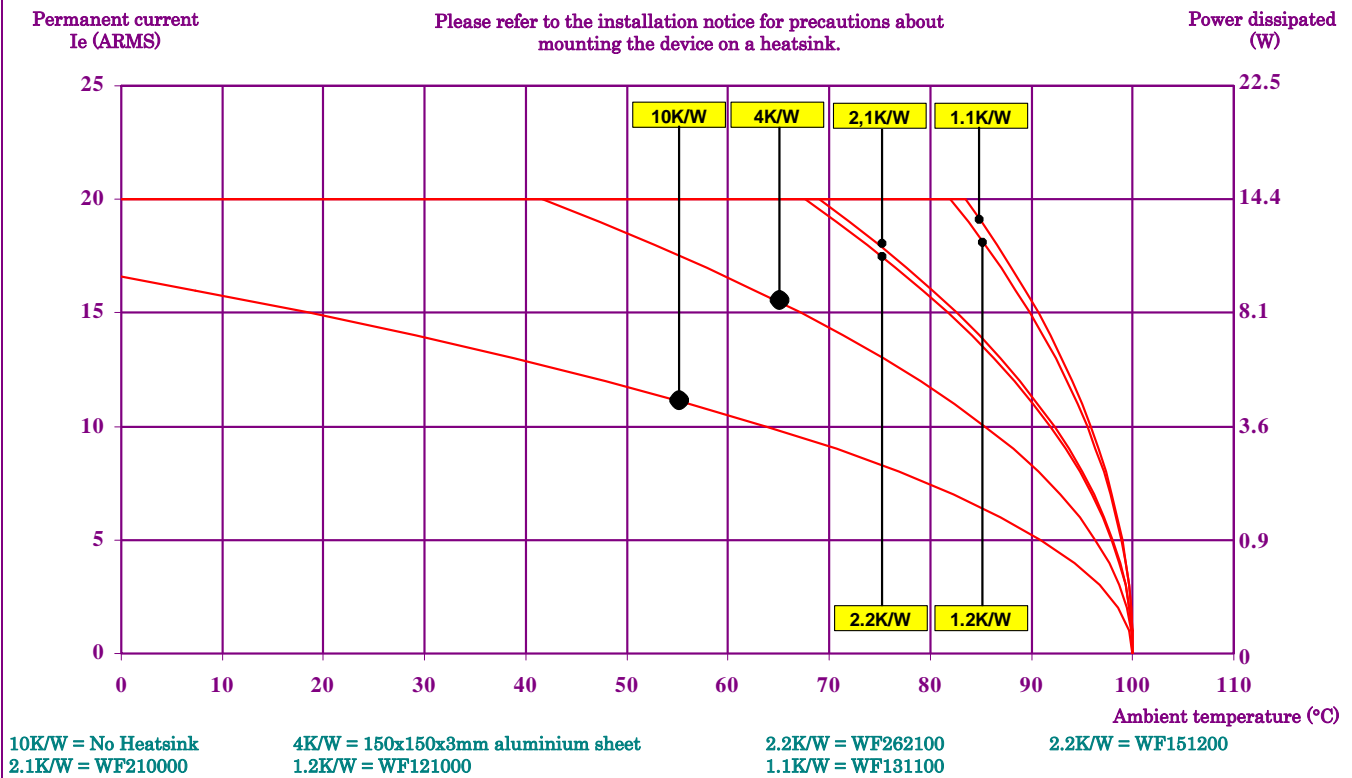
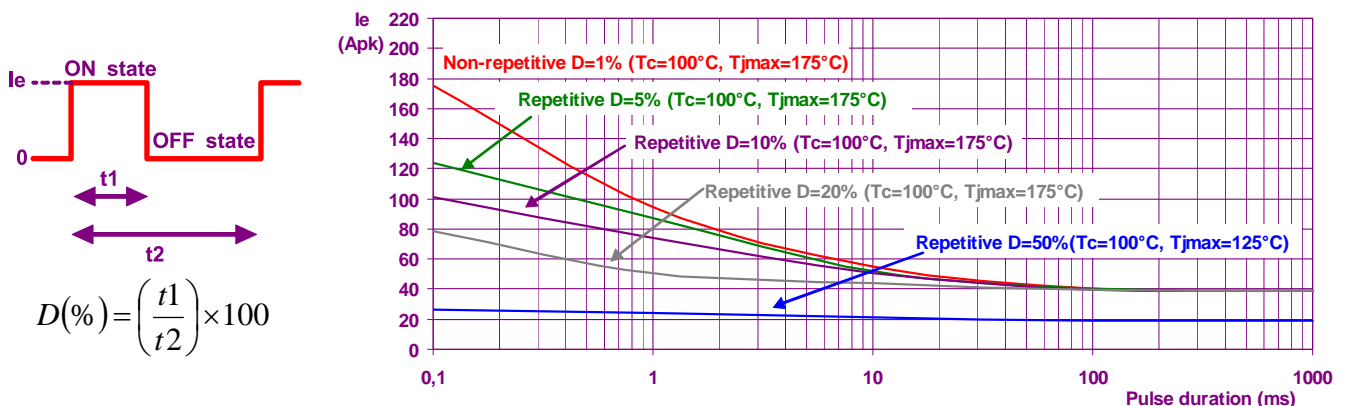

Fig. 8

PEAK OVERLOAD CURRENT vs. PULSE DURATION CHARACTERISTIC







CONNECTIONS



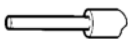

Direct connection with wires with or without ferrules

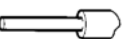

With ring terminals

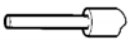

okpac [®]				Control wiring	
Number of wires				Screwdriver type	Recommended tightening torque M4 screw
1		2			
SOLID (No ferrule)	FINE STRANDED (With ferrule)	SOLID (No ferrule)	FINE STRANDED (With ferrule)		N.m
					
0,75 ... 2,5 mm ² AWG18...AWG14	0,75 ... 2,5 mm ² AWG18...AWG14	0,75 ... 2,5 mm ² AWG18...AWG14	0,75 ... 2,5 mm ² AWG18...AWG14	POZIDRIV 2	Mini 1,2 / Typ 1.5 / Max 2

okpac [®]				Power wiring	
Number of wires				Modèle de tournevis / Screwdriver type	Recommended tightening torque M5 screw
1		2			
SOLID (No ferrule)	FINE STRANDED (With ferrule)	SOLID (No ferrule)	FINE STRANDED (With ferrule)		N.m
					
1,5 ... 10 mm ² AWG16...AWG8	1,5 ... 6 mm ² AWG16...AWG10	1,5 ... 10 mm ² AWG16...AWG8	1,5 ... 6 mm ² AWG16...AWG10	POZIDRIV 2	Mini 2 / Typ 2.4 / Max 3

Power with ring terminals.

- W max = 12.0mm
- 16 mm² (AWG6)
- 25 mm² (AWG4)
- 35mm² (AWG2 / AWG3)
- 50mm² (AWG0 / AWG1)

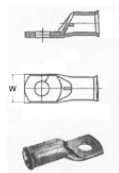

IP20 flaps

Flaps are delivered mounted on the relay.

Labels
Marking labels are available,
for mounting on flaps.
Part number : 1MZ09000
(delivered per 200 parts)



Suitable ring terminals and special kit for high current can be delivered: see high power SSR and data-sheet for power connection.

FASTONS : Consult us

DIMENSIONS AND ACCESSORIES

Fig. 12

DIMENSIONS (mm)

CAD documents : www.celduc-relais.uk/plan3D.asp

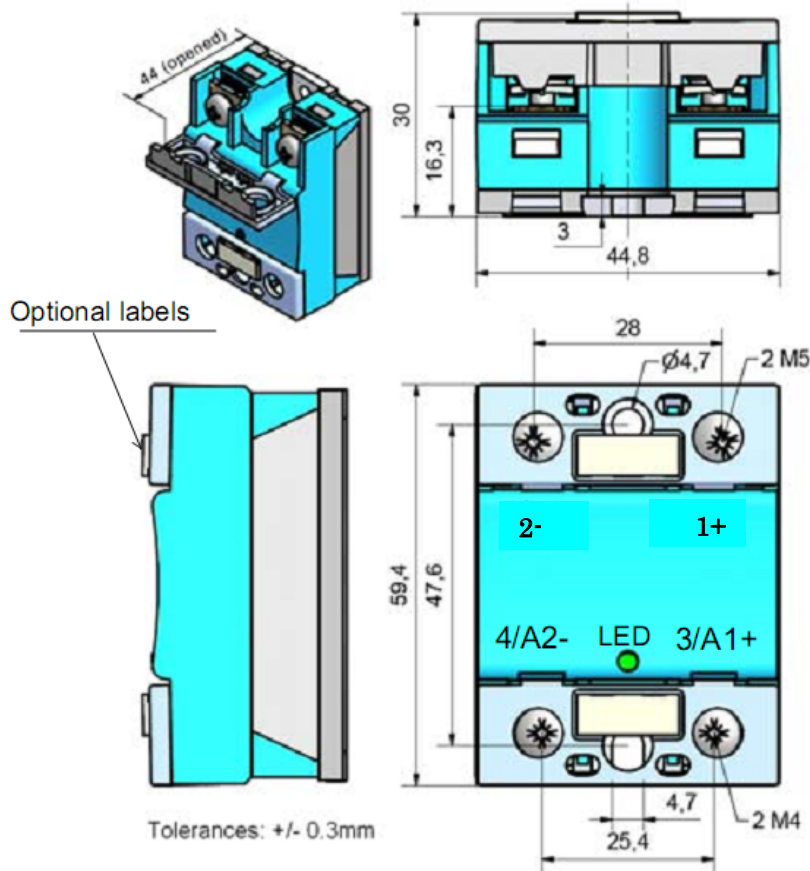

ACCESSORIES

**READY TO USE OVERVOLTAGE PROTECTION
ESO01000**

(Please check our website for availability)

This device includes a diode (D2) and a capacitor (C1) suitable for most of the DC application.

To be mounted close to the SOM.

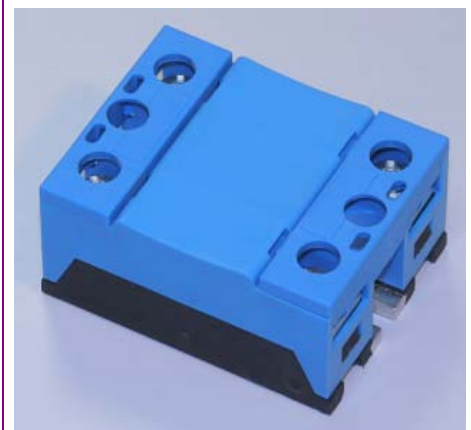

Please consult our website for other accessory references
(Heatsinks, mounting adaptors, thermal grease...)

X-ON Electronics

Largest Supplier of Electrical and Electronic Components

Click to view similar products for [Celduc](#) manufacturer:

Other Similar products are found below :

[2YB20051](#) [2YB20111](#) [D31A3100](#) [D31A5100](#) [D31A7110](#) [D32A3100](#) [D32A5100](#) [D71A2100](#) [ESD05000](#) [PAA10060](#) [PHA01200](#) [PLA10160](#)
[PLA13750](#) [PSA60010](#) [PSL40010](#) [PTA10440](#) [PTA10490](#) [PTA50010](#) [PTFA0100](#) [PTFA3115](#) [PTI40020](#) [PTPA0230](#) [PW520000](#) [PWB01501](#)
[SA842070](#) [SA942460](#) [SAL961360](#) [SC842110](#) [SC869110](#) [SCF42324](#) [SCF62160](#) [SCM0100200](#) [SCM030200](#) [SF541310](#) [SF542310](#)
[SF546310](#) [SGT8658500](#) [SGT8658502](#) [SGT8670500](#) [SGT8678500](#) [SGT8850200](#) [SGT965360E](#) [SGT9854300](#) [SILD867170](#) [SIT867570](#)
[SKA10420](#) [SKA20421](#) [SKA20440](#) [SKA20441](#) [SKB10440](#)