



SMD POWER INDUCTOR CKO Series

贴片功率电感 CKO 系列

● FEATURES 特性

Various high power inductors are superior to be high saturation for surface mounting.

具有高功率、高饱和电流、低电阻特性。



● APPLICATIONS 用途

Power supply for TVR,OA equipment, audio, LED television ,
communicaton equipments, DC/DC converters, etc.

录影机, OA仪器, 音箱, LED电视, 通信设备, DC/DC转换器

● PART NUMBERING SYSTEM 品名系统



● SHAPES AND DIMENSIONS 外形尺寸 (Unit:mm)

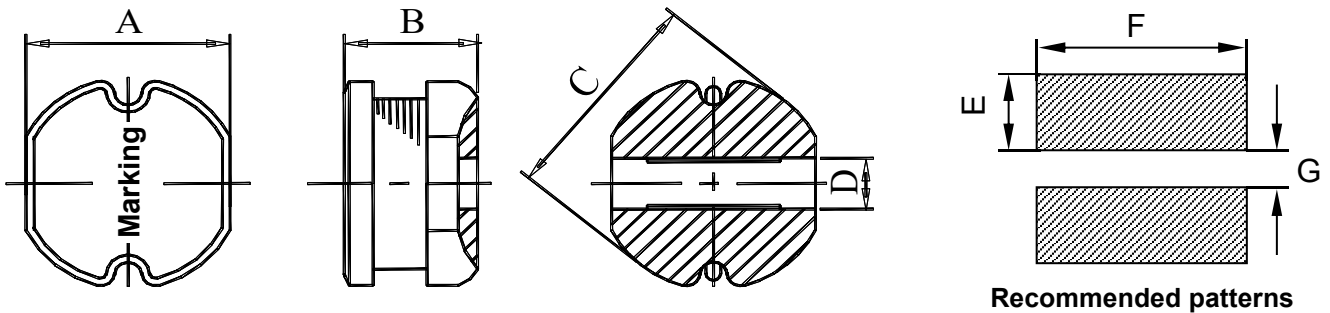

TYPE(型号)	A	B	C	D	E	F	G
CKO32	3.0±0.3	2.1±0.3	3.5±0.3	1.0	1.6	3.5	0.8
CKO43	4.0±0.3	3.2±0.3	4.5±0.3	1.4	1.75	4.5	1.2
CKO53	5.2±0.3	3.0±0.3	5.8±0.3	2.1	2.15	5.5	1.7
CKO54	5.2±0.3	4.5±0.3	5.8±0.3	2.1	2.15	5.5	1.7
CKO75	7.0±0.3	5.0±0.3	7.8±0.3	2.5	3.0	7.5	2.0
CKO104	9.0±0.3	4.0±0.3	10.0±0.3	3.1	3.75	9.5	2.5
CKO105	9.0±0.3	5.4±0.3	10.0±0.3	3.1	3.75	9.5	2.5
CKO106	9.0±0.3	6.5±0.5	10.0±0.3	3.1	3.75	9.5	2.5
CKO108	9.0±0.3	8.3±0.5	10.0±0.3	3.1	3.75	9.5	2.5



● SPECIFICATION TABLE 规格特性表

CKO32

PART NUMBER 品名	INDUCTANCE (uH) 电感值	DCR (Max) (Ω) 直流电阻	IDC (Max) (A) 额定电流
CKO32-1uH/N	1±30%	0.045	2.20
CKO32-1.5uH/N	1.5±30%	0.055	2.00
CKO32-2.2uH/M	2.2±20%	0.09	1.80
CKO32-3.3uH/M	3.3±20%	0.11	1.70
CKO32-4.7uH/M	4.7±20%	0.15	1.50
CKO32-6.8uH/M	6.8±20%	0.22	1.10
CKO32-10uH/M	10±20%	0.27	0.90
CKO32-15uH/M-012	15±20%	0.42	0.70
CKO32-22uH/M	22±20%	0.68	0.60
CKO32-33uH/M	33±20%	0.90	0.45
CKO32-47uH/M	47±20%	1.20	0.30
CKO32-56uH/M	56±20%	1.40	0.28
CKO32-68uH/M	68±20%	1.80	0.25
CKO32-82uH/M	82±20%	2.10	0.22
CKO32-100uH/M	100±20%	2.40	0.20
CKO32-150uH/M	150±20%	3.80	0.15

Remark: 1. All test data is reference to 25°C ambient.

2. Inductance Tested at 100kHz,0.25Vrms

3. IDC: DC current at which the inductance drops approximate 20% from its value without current;

4. Operating Temperature : -40°C ~ +125°C(Including self - temperature rise)



CKO43

PART NUMBER 品名	INDUCTANCE (uH) 电感值	DCR (Max) (Ω) 直流电阻	IDC (Max) (A) 额定电流
CKO43-1uH/N-030	1±30%	0.025	3.00
CKO43-1.5uH/N-029	1.5±30%	0.032	2.70
CKO43-2.2uH/M-025	2.2±20%	0.045	2.50
CKO43-3.3uH/M-023	3.3±20%	0.065	2.10
CKO43-4.7uH/M-023	4.7±20%	0.075	1.80
CKO43-6.8uH/M	6.8±20%	0.10	1.60
CKO43-10uH/M-020	10±20%	0.14	1.20
CKO43-15uH/M-017	15±20%	0.23	1.00
CKO43-22uH/M	22±20%	0.30	0.75
CKO43-33uH/M	33±20%	0.42	0.70
CKO43-47uH/M	47±20%	0.58	0.50
CKO43-68uH/M	68±20%	0.935	0.45
CKO43-82uH/M	82±20%	1.00	0.40
CKO43-100uH/□	100±10% / ±20%	1.30	0.30
CKO43-150uH/□	150±10% / ±20%	2.00	0.25
CKO43-220uH/□	220±10% / ±20%	2.70	0.20
CKO43-330uH/□	330±10% / ±20%	3.60	0.18
CKO43-470uH/□	470±10% / ±20%	6.00	0.15

Remark: 1. All test data is reference to 25°C ambient.

2. Inductance Tested at 100kHz,0.25Vrms

3. IDC: DC current at which the inductance drops approximate 20% from its value without current;

4. Operating Temperature : -40°C ~ +125°C(Including self - temperature rise)

5. □ Tolerance: M:±20% , K:±10%



CKO53

PART NUMBER 品名	INDUCTANCE (uH) 电感值	DCR (Max) (Ω) 直流电阻	IDC (Max) (A) 额定电流
CKO53-1uH/N	1±30%	0.028	6.00
CKO53-1.5uH/N	1.5±30%	0.035	3.50
CKO53-2.2uH/M-030	2.2±20%	0.04	3.00
CKO53-3.3uH/M	3.3±20%	0.055	2.80
CKO53-4.7uH/M	4.7±20%	0.07	2.60
CKO53-6.8uH/M	6.8±20%	0.09	2.40
CKO53-10uH/M	10±20%	0.12	2.00
CKO53-15uH/M	15±20%	0.18	1.80
CKO53-22uH/M	22±20%	0.26	1.60
CKO53-33uH/M	33±20%	0.38	1.20
CKO53-47uH/M-015	47±20%	0.57	1.00
CKO53-68uH/M-014	68±20%	0.68	0.80
CKO53-82uH/M	82±20%	0.86	0.70
CKO53-100uH/□	100±10% / ±20%	0.96	0.65
CKO53-220uH/□	220±10% / ±20%	2.10	0.30
CKO53-330uH/□	330±10% / ±20%	4.00	0.25
CKO53-470uH/□	470±10% / ±20%	5.30	0.20
CKO53-680uH/□-008	680±10% / ±20%	8.00	0.18

Remark: 1. All test data is reference to 25°C ambient.

2. Inductance Tested at 100kHz,0.25Vrms

3. IDC: DC current at which the inductance drops approximate 20% from its value without current;

4. Operating Temperature : -40°C ~ +125°C(Including self - temperature rise)

5. □ Tolerance: M:±20% , K:±10%



CKO54

PART NUMBER 品名	INDUCTANCE (uH) 电感值	DCR (Max) (Ω) 直流电阻	IDC (Max) (A) 额定电流
CKO54-1.2uH/N-037	1.2±30%	0.019	4.50
CKO54-1.5uH/N-037	1.5±30%	0.021	4.20
CKO54-2.2uH/M-035	2.2±20%	0.026	3.50
CKO54-3.3uH/M-035	3.3±20%	0.035	3.00
CKO54-4.7uH/M-032	4.7±20%	0.045	2.80
CKO54-6.8uH/M-032	6.8±20%	0.06	2.50
CKO54-10uH/M-030	10±20%	0.08	2.30
CKO54-15uH/M	15±20%	0.12	1.80
CKO54-22uH/M	22±20%	0.15	1.20
CKO54-33uH/M-024	33±20%	0.22	1.00
CKO54-47uH/M	47±20%	0.36	0.85
CKO54-68uH/M-019	68±20%	0.46	0.60
CKO54-82uH/M	82±20%	0.53	0.55
CKO54-100uH/□	100±10% / ±20%	0.70	0.50
CKO54-220uH/□-014	220±10% / ±20%	1.60	0.40
CKO54-330uH/□-011	330±10% / ±20%	2.70	0.30
CKO54-470uH/□-011	470±10% / ±20%	3.60	0.28
CKO54-1mH/□	1000±10% / ±20%	5.60	0.12

Remark: 1. All test data is reference to 25°C ambient.

2. Inductance Tested at 100kHz,0.25Vrms

3. IDC: DC current at which the inductance drops approximate 20% from its value without current;

4. Operating Temperature : -40°C ~ +125°C(Including self - temperature rise)

5. □ Tolerance: M:±20% , K:±10%



CKO75

PART NUMBER 品名	INDUCTANCE (μ H) 电感值	DCR (Max) (Ω) 直流电阻	IDC (Max) (A) 额定电流
CKO75-1uH/N	1 \pm 30%	0.018	5.50
CKO75-1.5uH/N	1.5 \pm 30%	0.025	5.30
CKO75-2.2uH/N-045	2.2 \pm 30%	0.03	5.00
CKO75-3.3uH/M-040	3.3 \pm 20%	0.04	4.50
CKO75-4.7uH/M-040	4.7 \pm 20%	0.05	4.00
CKO75-6.8uH/M-040	6.8 \pm 20%	0.06	3.50
CKO75-10uH/M	10 \pm 20%	0.08	2.80
CKO75-15uH/M-035	15 \pm 20%	0.09	2.70
CKO75-22uH/M-032	22 \pm 20%	0.12	2.20
CKO75-33uH/M-030	33 \pm 20%	0.18	1.50
CKO75-47uH/M-029	47 \pm 20%	0.21	1.20
CKO75-68uH/M-026	68 \pm 20%	0.29	1.00
CKO75-100uH/ \square	100 \pm 10% / \pm 20%	0.41	0.80
CKO75-220uH/ \square -020	220 \pm 10% / \pm 20%	0.78	0.60
CKO75-330uH/ \square	330 \pm 10% / \pm 20%	1.42	0.40
CKO75-470uH/ \square	470 \pm 10% / \pm 20%	2.00	0.30
CKO75-1mH/ \square -013	1000 \pm 10% / \pm 20%	4.00	0.25
CKO75-1.2mH/ \square	1200 \pm 10% / \pm 20%	4.70	0.23
CKO75-1.5mH/ \square	1500 \pm 10% / \pm 20%	5.70	0.20
CKO75-2.2mH/ \square	2200 \pm 10% / \pm 20%	8.00	0.10

Remark: 1. All test data is reference to 25 $^{\circ}$ C ambient.

2. Inductance Tested at 100kHz,0.25Vrms

3. IDC: DC current at which the inductance drops approximate 20% from its value without current;

4. Operating Temperature : -40 $^{\circ}$ C ~ +125 $^{\circ}$ C(Including self - temperature rise)

5. \square Tolerance: M: \pm 20% , K: \pm 10%



CKO104

PART NUMBER 品名	INDUCTANCE (μ H) 电感值	DCR (Max) (Ω) 直流电阻	IDC (Max) (A) 额定电流
CKO104-10uH/M	10 \pm 20%	0.06	4.00
CKO104-15uH/M	15 \pm 20%	0.09	3.50
CKO104-22uH/M	22 \pm 20%	0.14	2.80
CKO104-33uH/M-032	33 \pm 20%	0.16	2.50
CKO104-47uH/M	47 \pm 20%	0.20	2.10
CKO104-68uH/M	68 \pm 20%	0.27	1.50
CKO104-82uH/M	82 \pm 20%	0.33	1.40
CKO104-100uH/ \square	100 \pm 10% / \pm 20%	0.42	1.20
CKO104-220uH/ \square	220 \pm 10% / \pm 20%	1.00	0.80
CKO104-330uH/ \square	330 \pm 10% / \pm 20%	1.30	0.65
CKO104-470uH/ \square	470 \pm 10% / \pm 20%	1.80	0.60
CKO104-560uH/ \square	560 \pm 10% / \pm 20%	2.10	0.55
CKO104-680uH/ \square	680 \pm 10% / \pm 20%	2.50	0.50
CKO104-820uH/ \square	820 \pm 10% / \pm 20%	2.90	0.40
CKO104-1mH/ \square	1000 \pm 10% / \pm 20%	3.70	0.35

Remark: 1. All test data is reference to 25 $^{\circ}$ C ambient.

2. Inductance Tested at 100kHz,0.25Vrms

3. IDC: DC current at which the inductance drops approximate 20% from its value without current;

4. Operating Temperature : -40 $^{\circ}$ C ~ +125 $^{\circ}$ C(Including self - temperature rise)

5. \square Tolerance: M: \pm 20% , K: \pm 10%



CKO105

PART NUMBER 品名	INDUCTANCE (uH) 电感值	DCR (Max) (Ω) 直流电阻	IDC (Max) (A) 额定电流
CKO105-4.7uH/M	4.7±20%	0.035	5.00
CKO105-6.8uH/M	6.8±20%	0.04	4.50
CKO105-10uH/M	10±20%	0.06	4.00
CKO105-15uH/M	15±20%	0.08	3.00
CKO105-22uH/M	22±20%	0.10	2.50
CKO105-33uH/M	33±20%	0.15	2.10
CKO105-47uH/M	47±20%	0.17	1.80
CKO105-68uH/M-030	68±20%	0.25	1.50
CKO105-100uH/□-029	100±10% / ±20%	0.30	1.20
CKO105-150uH/□	150±10% / ±20%	0.43	1.10
CKO105-220uH/□	220±10% / ±20%	0.70	0.80
CKO105-330uH/□	330±10% / ±20%	0.90	0.65
CKO105-470uH/□	470±10% / ±20%	1.30	0.55
CKO105-680uH/□-018	680±10% / ±20%	1.75	0.45
CKO105-1mH/□	1000±10% / ±20%	2.70	0.35
CKO105-1.2mH/□	1200±10% / ±20%	3.50	0.30
CKO105-1.5mH/□	1500±10% / ±20%	3.90	0.25
CKO105-1.8mH/□	1800±10% / ±20%	5.00	0.20
CKO105-3mH/□	3000±10% / ±20%	8.50	0.15

Remark: 1. All test data is reference to 25°C ambient.

2. Inductance Tested at 100kHz,0.25Vrms

3. IDC: DC current at which the inductance drops approximate 20% from its value without current;

4. Operating Temperature : -40°C ~ +125°C(Including self - temperature rise)

5. □ Tolerance: M:±20% , K:±10%



CKO106

PART NUMBER 品名	INDUCTANCE (μ H) 电感值	DCR (Max) (Ω) 直流电阻	IDC (Max) (A) 额定电流
CKO106-1mH/K	1000 \pm 10%	2.8	0.60
CKO106-1.2mH/K	1200 \pm 10%	3.0	0.50
CKO106-2.2mH/K	2200 \pm 10%	5.7	0.35
CKO106-3mH/K	3000 \pm 10%	7.2	0.30
CKO106-3.5mH/K	3500 \pm 10%	9.1	0.26
CKO106-4.5mH/K	4500 \pm 10%	11.5	0.20
CKO106-4.7mH/K	4700 \pm 10%	12.1	0.18

CKO108

PART NUMBER 品名	INDUCTANCE (μ H) 电感值	DCR (Max) (Ω) 直流电阻	IDC (Max) (A) 额定电流
CKO108-100uH/M	100 \pm 20%	0.236	2.00
CKO108-300uH/M	300 \pm 20%	0.581	1.20
CKO108-350uH/M	350 \pm 20%	0.660	1.00
CKO108-500uH/M	500 \pm 20%	0.956	0.80
CKO108-1mH/K	1000 \pm 10%	1.80	0.60
CKO108-1.5mH/K	1500 \pm 10%	2.85	0.50
CKO108-2mH/K	2000 \pm 10%	3.64	0.40
CKO108-2.5mH/K	2500 \pm 10%	5.20	0.35
CKO108-2.8mH/K	2800 \pm 10%	5.53	0.34
CKO108-3mH/K	3000 \pm 10%	6.08	0.33
CKO108-4mH/K	4000 \pm 10%	7.80	0.28

Remark: 1. All test data is reference to 25 $^{\circ}$ C ambient.

2. Inductance Tested at 100kHz,0.25Vrms

3. IDC: DC current at which the inductance drops approximate 20% from its value without current;

4. Operating Temperature : -40 $^{\circ}$ C ~ +125 $^{\circ}$ C(Including self - temperature rise)

5. Tolerance: M: \pm 20% , K: \pm 10%

● **PACKAGING SPECIFICATION 包装规格**

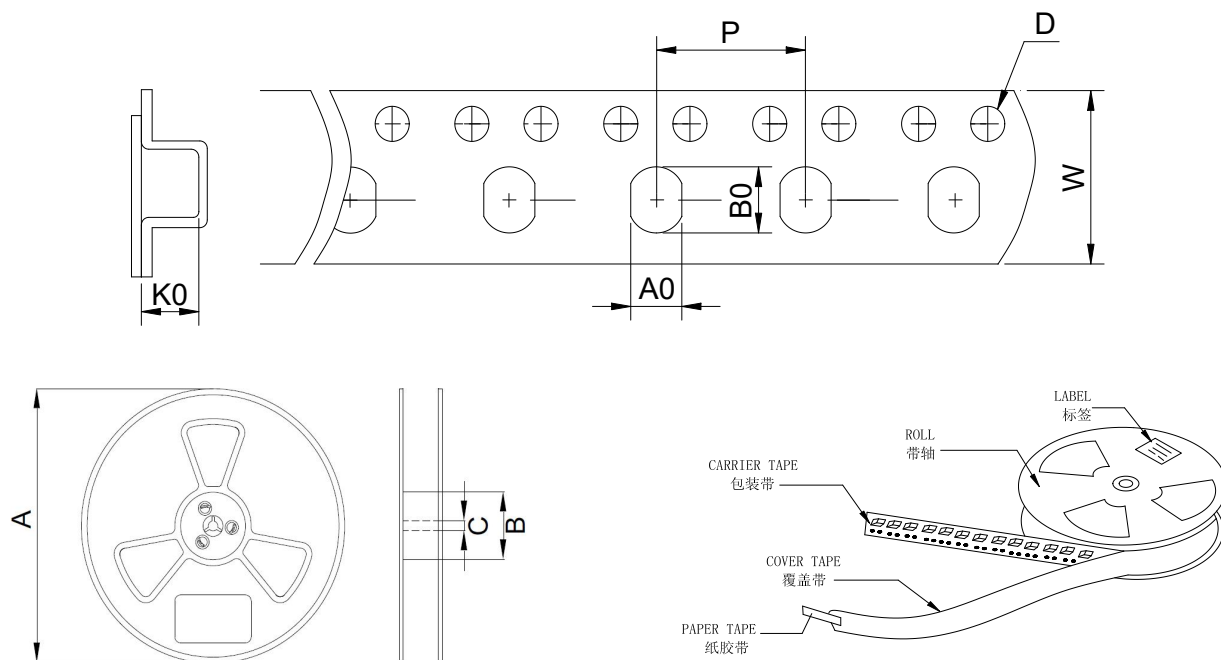

TYPE(型号)	Tape Dimension 载带尺寸(mm)						Reel Dimension 卷盘尺寸 (mm)			Quantity (Pcs/Reel) 数量 (个/卷)
	W	A0	B0	K0	D	P	A	B	C	
CKO32	12.0	3.3	3.8	2.5	1.5	8.0	330	100	13	3000
CKO43	12.0	4.2	4.8	3.5	1.5	8.0	330	100	13	2000
CKO53	12.0	5.5	6.1	3.6	1.5	8.0	330	100	13	2000
CKO54	12.0	5.6	6.3	5.2	1.5	8.0	330	100	13	1500
CKO75	16.0	7.6	8.6	5.6	1.5	12.0	330	100	13	1000
CKO104	24.0	9.1	10.1	4.8	1.5	12.0	330	100	13	1000
CKO105	24.0	9.1	10.1	6.1	1.5	12.0	330	100	13	1000
CKO106	24.0	9.1	10.1	7.3	1.5	12.0	330	100	13	750
CKO108	24.0	9.1	10.1	9.0	1.5	12.0	330	100	13	500

X-ON Electronics

Largest Supplier of Electrical and Electronic Components

Click to view similar products for [Fixed Inductors](#) category:

Click to view products by [CENKER](#) manufacturer:

Other Similar products are found below :

[CR32NP-151KC](#) [CR32NP-180KC](#) [CR32NP-181KC](#) [CR32NP-1R5MC](#) [CR32NP-390KC](#) [CR32NP-3R9MC](#) [CR32NP-680KC](#) [CR32NP-820KC](#) [CR32NP-8R2MC](#) [CR43NP-390KC](#) [CR43NP-560KC](#) [CR43NP-680KC](#) [CR54NP-181KC](#) [CR54NP-470LC](#) [CR54NP-820KC](#) [CR54NP-8R5MC](#) [70F224AI](#) [MGDQ4-00004-P](#) [MHL1ECTTP18NJ](#) [MHQ1005P10NJ](#) [MHQ1005P1N0S](#) [MHQ1005P2N4S](#) [MHQ1005P3N6S](#) [MHQ1005P5N1S](#) [MHQ1005P8N2J](#) [PE-51506NL](#) [PE-53601NL](#) [PE-53602NL](#) [PE-53630NL](#) [PE-53824SNLT](#) [PE-92100NL](#) [PG0434.801NLT](#) [PG0936.113NLT](#) [9220-20](#) [9310-16](#) [PM06-2N7](#) [PM06-39NJ](#) [A01TK](#) [1206CS-471XJ](#) [HC2LP-R47-R](#) [HC2-R47-R](#) [HC3-2R2-R](#) [HCF1305-3R3-R](#) [1206CS-151XG](#) [RCH664NP-140L](#) [RCH664NP-4R7M](#) [RCH8011NP-221L](#) [RCP1317NP-332L](#) [RCP1317NP-391L](#) [RCR1010NP-470M](#)